



## LETTER TO INDUSTRY - POTENTIAL BYPASS BALLAST WATER MANAGEMENT SYSTEM (BWMS) WITHOUT ALARM ACTIVATION

This notice provides an overview of the recent Port State Control (PSC) detentions relating to Ballast Water Management System (BWMS).

### BACKGROUND

Recent ship detentions occurred in certain ports in the Tokyo MoU concerning ballast water management system (BWMS) arrangements and associated valves.

The PSC deficiency typically states that the piping arrangement of the ballast water management system may permit the system to be bypassed during ballast uptake and discharge operations without activating an alarm. The most recent PSC cases reference Section 7 of the BWMS Code (IMO Resolution MEPC.300(72)) while older cases have not provided a citation.

**Section 7.2 of the BWMS Code reads:** *Suitable bypasses or overrides to protect the safety of the ship and personnel shall be installed and used in the event of an emergency and these shall be connected to the BWMS so that any bypass of the BWMS shall activate an alarm. The bypass event shall be recorded by the control and monitoring equipment and within the ballast water record book.*

It is noted that the BWMS Code (Resolution MEPC.300(72)) and, where applicable, the previous Resolution MEPC.279(70) (G8 Guidelines) establish specific technical boundaries for the BWMS. In this context, the valves in question are located outside the defined boundaries of the BWMS, since section 3.2 of the BWMS Code clarifies that for the purpose of the Code, BWMS does not include the ship's ballast water fittings, which may include piping, valves, pumps, etc., that would be required if the BWMS was not fitted.

Nevertheless, the PSC authorities maintain that the overall ballast water treatment and discharge from the vessel must meet the minimum standards prescribed by the Convention. They argue that all bypass valves should not be limited solely to those with control functions as required under the BWMS Code and the G8 Guidelines; rather, any uncontrolled bypass valves that go beyond what the Rules explicitly require would run counter to the compliance spirit of the Ballast Water Management Convention.

### KEY NOTES

- The piping arrangement of the ballast water management system may permit the system to be bypassed during ballast uptake and discharge operations without activating an alarm, which may cause PSC deficiency.
- References:
  - [Resolution MEPC.279\(70\)](#)
  - [Resolution MEPC.300\(72\)](#)

## EXAMPLE VALVE ARRANGEMENT OUTSIDE THE BWMS BOUNDARY

In the arrangement sketch shown below, if the V01 & V02 or V03 & V04 on each side are opened simultaneously, although without ballast pump running, the vessel may ballast and de-ballast through the red line. Some designs do not provide an alarm when the two valves on each side are opened together.

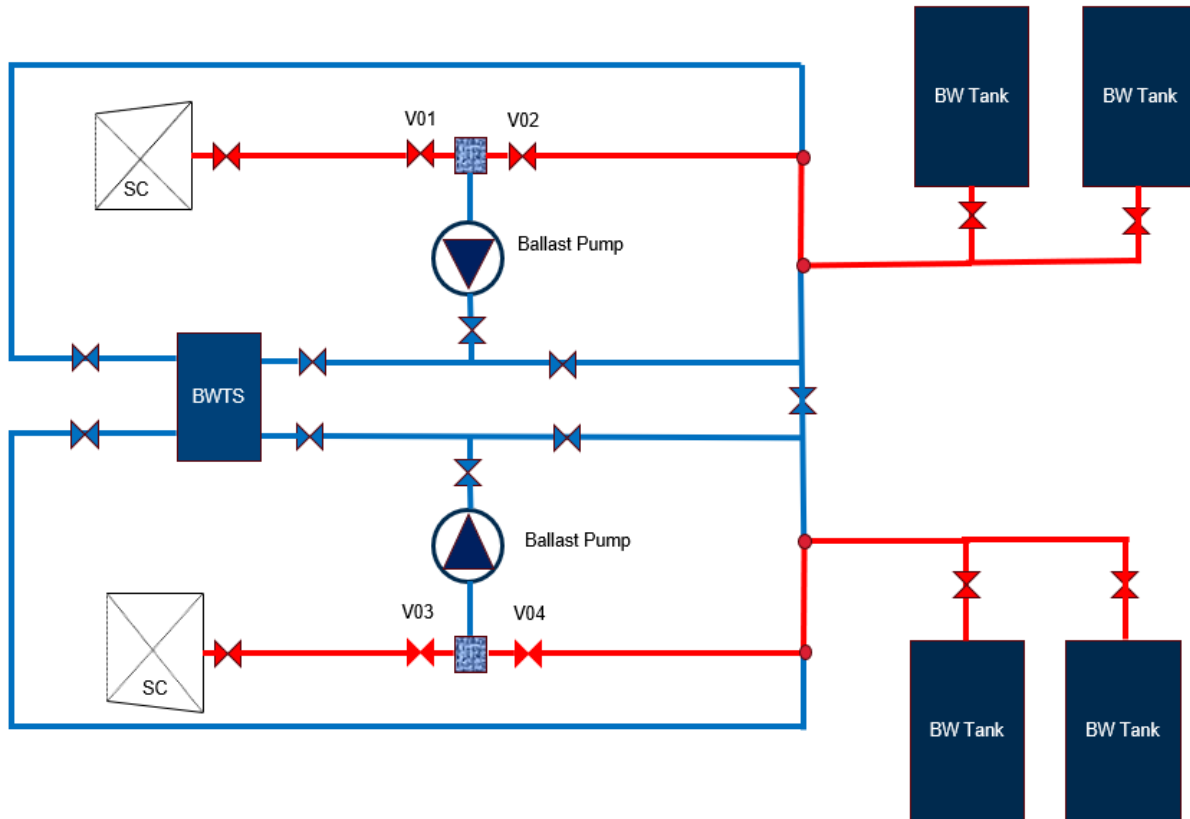

*Example valve arrangement that is outside the boundary considered under the Code.*

The above arrangement has been accepted on the basis of the provisions of the BWMS Code and the G8 Guidelines; since the valves V01 & V02 or V03 & V04 are located outside the defined boundaries of the BWMS. Nevertheless, in some of the newer designs, valves designated by the designer as “bypass” valves are fitted with alarms while interlocks may also be provided to prevent simultaneous valve operations (Note: “interlock” is not a term used in the BWMS Code.)

## ABS RECOMMENDATION

As some PSC regimes have taken the position that the boundary of the BWMS in the Code includes piping that is outside of the BWMS itself, ABS recommends the following to prevent the simultaneous opening of these valves that are located outside the defined boundaries of the system but may be considered capable of bypassing the system without activating an alarm:

1. Onboard review by the crew evaluating all possible scenarios, including ballasting or de-ballasting by gravity.
2. The ballast water inlet and discharge valves are to be locked and placed under the control of a designated responsible person.
3. Warning signs are to be posted clearly stating that ballast water discharge is prohibited unless it passes through the BWMS.
4. Relevant instructions to be included in the ballast water management plan.
5. Crew members are to be trained, and training records are to be maintained for future reference.

If you decide to modify the existing arrangements to include an alarm and/or interlock function, a formal review is required.

Should you have any questions, please contact your [local ABS Office](#).

## IMO REVIEW OF THE BALLAST WATER MANAGEMENT CONVENTION

The Marine Environment Protection Committee (MEPC), at its eightieth session, approved the Convention Review Plan (CRP), as set out in BWM.2/Circ.79, with the aim of defining a precise and workable scope for reviewing the Ballast Water Management Convention based upon clear principles that promote practicality, protectiveness, take a holistic view and achieve desired policy outcomes. The recent MEPC 84 made decisive progress on the comprehensive revision of the Ballast Water Management (BWM) framework. The Committee:

- Finalized and approved amendments to the BWM Convention for adoption at the next MEPC session.
- Adopted new 2026 Guidelines for Ballast Water Management and Ballast Water Management Plans (G4).
- Advanced, but did not yet finalize, amendments to the BWMS Code, targeting approval at MEPC 85.
- Confirmed policy intent for simultaneous entry into force of the Convention amendments and the revised BWMS Code, formally closing the Experience Building Phase.

## AMENDMENTS TO THE BWMS CODE

MEPC 84 re-established the Correspondence Group on the Review of the BWM Convention, with priority given to finalizing the remaining amendments to the BWMS Code. A progress report is expected at MEPC 85, followed by a written report at MEPC 86. The approval and adoption of the associated revised or new guidelines, developed in response to the BWM Convention amendments, are anticipated to be completed by MEPC 87, ensuring alignment between the regulatory framework and practical implementation.

The Correspondence Group has agreed to amend Section 3 (Definitions), specifically Section 3.2 of the BWMS Code, to clarify that: *Ballast water system means the BWMS and the ship's ballast water fittings, which may include piping, valves, pumps, etc., that would be required if the BWMS was not fitted.*

In light of the above regulatory developments, attention should be given to arrangements enabling simultaneous opening of these valves that are located outside the defined boundaries of the system but may be considered capable of bypassing the system without activating an alarm, with a view to ensuring consistent implementation and preventing the potential discharge of untreated ballast water in such circumstances.

### WORLD HEADQUARTERS

1701 City Plaza Drive | Spring, TX 77389 USA

P 1-281-877-6000 | F 1-281-877-5976

ABS-WorldHQ@eagle.org

www.eagle.org

© 2026 American Bureau of Shipping. All rights reserved.

