



RULES FOR BUILDING AND CLASSING

**MARINE VESSELS
2018**

**PART 4
VESSEL SYSTEMS AND MACHINERY**

(Updated August 2018 – see next page)

**American Bureau of Shipping
Incorporated by Act of Legislature of
the State of New York 1862**

**© 2017-2018 American Bureau of Shipping. All rights reserved.
1701 City Plaza Drive
Spring, TX 77389 USA**

Updates

August 2018 consolidation includes:

- July 2018 version plus Corrigenda/Editorials

July 2018 consolidation includes:

- March 2018 version plus Notice No. 1 and Corrigenda/Editorials

March 2018 consolidation includes:

- January 2018 version plus Corrigenda/Editorials

Rule Change Notice (2018)

The effective date of each technical change since 1993 is shown in parenthesis at the end of the subsection/paragraph titles within the text of each Part. Unless a particular date and month are shown, the years in parentheses refer to the following effective dates:

(2000) and after	1 January 2000 (and subsequent years)	(1996)	9 May 1996
(1999)	12 May 1999	(1995)	15 May 1995
(1998)	13 May 1998	(1994)	9 May 1994
(1997)	19 May 1997	(1993)	11 May 1993

Listing by Effective Dates of Changes from the 2018 Rules

Notice No. 1 (effective on 1 July 2018) to the 2018 Rules, is summarized below.

EFFECTIVE DATE 1 July 2018 – shown as (1 July 2018)
(based on the contract date for new construction between builder and Owner)

<i>Part/Para. No.</i>	<i>Title/Subject</i>	<i>Status/Remarks</i>
4-1-1/7.5.1	General	To specify requirements for on-board tests for commissioning of essential equipment and systems for propulsion, in line with IACS UR M25. (Incorporates Notice No. 1)
4-2-1/1.1	Application	To link the engine requirements given by the base rules to the additional requirements of the ABS <i>Exhaust Emission Abatement Guide</i> and to add a cross reference to the locations in the Rules where additional requirements for dual fuel and gas engines are located. (Incorporates Notice No. 1)
4-2-1/1.9.4	Materials	To update the requirements for evaluation of stress concentration factors (SCF) by finite elements calculation, evaluation of stress in oil bore and fillets when surface treatment process is applied, and evaluation of fatigue strength by experiment (fatigue tests), in line with IACS UR M53. (Incorporates Notice No. 1)
4-2-1/5.9.4(a)	General	To update the requirements for evaluation of stress concentration factors (SCF) by finite elements calculation, evaluation of stress in oil bore and fillets when surface treatment process is applied, and evaluation of fatigue strength by experiment (fatigue tests), in line with IACS UR M53. (Incorporates Notice No. 1)
4-2-1/5.9.7	Calculation of Fatigue Strength	To update the requirements for evaluation of stress concentration factors (SCF) by finite elements calculation, evaluation of stress in oil bore and fillets when surface treatment process is applied, and evaluation of fatigue strength by experiment (fatigue tests), in line with IACS UR M53. (Incorporates Notice No. 1)
4-2-1/7.7	Materials other than Steel on Engine, Turbine and Gearbox Installations	To align the requirements for use of materials other than steel with IACS UI SC282. (Incorporates Notice No. 1)
4-2-1/13.9.4	Engines Driving Generators for Auxiliary Purposes	To refer to the requirements for engines driving generators dedicated for propulsion motors. (Incorporates Notice No. 1)
4-2-1A8 (New)	Guidance for Evaluation of Fatigue Tests	To provide guidance on the evaluation of fatigue tests, in line with IACS UR M53. (Incorporates Notice No. 1)
4-2-1A9 (New)	Guidance for Calculation of Surface Treated Fillets and Oil Bore Outlets	To provide guidance on surface treated fillets and oil bore outlets, in line with IACS UR M53. (Incorporates Notice No. 1)
4-2-1A10 (New)	Guidance for Calculation of Stress Concentration Factors in the Oil Bore Outlets of Crankshafts through Utilization of the Finite Element Method	To provide guidance on the calculation of stress concentration factors in the oil bore outlets of crankshafts through utilization of the finite element method, in line with IACS UR M53. (Incorporates Notice No. 1)

<i>Part/Para. No.</i>	<i>Title/Subject</i>	<i>Status/Remarks</i>
4-3-2/7.9.1	General	To ensure that no whirling critical speed would fall within “the range of $\pm 20\%$ of maximum continuous rating (M.C.R.) speed”. (Incorporates Notice No. 1)
4-3-2/7.9.2(b)	<No Title>	To clarify the interpretation of the Rules, which require a frequency analysis only. (Incorporates Notice No. 1)
4-3-2/11.3.3	Measurements for Whirling Vibrations	To clarify the interpretation of the Rules, which require a frequency analysis only. (Incorporates Notice No. 1)
4-3-2/15 (New)	Tailshaft Condition Monitoring (TCM-W)	To extend the TCM notation to water lubricated bearings, which will benefit from not having to withdraw the tailshaft every 5 years if the requirements of the Notation are fulfilled. (Incorporates Notice No. 1)
4-3-2/Table 5 (New)	Instrumentation and Alarm	To extend the TCM notation to water lubricated bearings, which will benefit from not having to withdraw the tailshaft every 5 years if the requirements of the Notation are fulfilled. (Incorporates Notice No. 1)
4-5-1/1.5	Plans and Particulars to be Submitted	To address incidents of anchor windlass failure, in line with IACS UR A3. (Incorporates Notice No. 1)
4-5-1/5.1.2	Continuous Duty Pull	To address incidents of anchor windlass failure, in line with IACS UR A3. (Incorporates Notice No. 1)
4-5-1/5.1.3	Overload Capability	To address incidents of anchor windlass failure, in line with IACS UR A3. (Incorporates Notice No. 1)
4-5-1/5.7 (New)	Protection of Mechanical Components	To address incidents of anchor windlass failure, in line with IACS UR A3. (Incorporates Notice No. 1)
4-5-1/5.9 (New)	Couplings	To address incidents of anchor windlass failure, in line with IACS UR A3. (Incorporates Notice No. 1)
4-5-1/7ii)	Load Test	To address incidents of anchor windlass failure, in line with IACS UR A3. (Incorporates Notice No. 1)
4-5-1/11 (New)	Marking	To address incidents of anchor windlass failure, in line with IACS UR A3. (Incorporates Notice No. 1)
4-6-2/3.5	Other Materials	To align the Rules with IACS UI SC282. (Incorporates Notice No. 1)
4-6-2/7.3.2	Hydrostatic Tests of Shell Valves	To standardize the test process for these type of valves. (Incorporates Notice No. 1)
4-6-5/5.1.3	Vessel Inclination	To clarify that the engine must remain operational at all acceptable filling levels and angles of inclination. (Incorporates Notice No. 1)
4-6-5/11.1	Application	To link the Rules to the additional requirements of the <i>ABS Guide for Exhaust Emission Abatement</i> , since the Guide includes minimum required safety requirements to be complied with in all cases where EEA systems are fitted to ABS ships, regardless of whether or not a Notation is being sought (Incorporates Notice No. 1)
4-6-5/11.15 (New)	Exhaust Emission Abatement Systems	To link the Rules to the additional requirements of the <i>ABS Guide for Exhaust Emission Abatement</i> , since the Guide includes minimum required safety requirements to be complied with in all cases where EEA systems are fitted to ABS ships, regardless of whether or not a Notation is being sought (Incorporates Notice No. 1)
4-6-6/9.1.3	Vessel Inclination	To clarify that the engine must remain operational at all acceptable filling levels and angles of inclination. (Incorporates Notice No. 1)
4-9-3/1	Application	To incorporate the wording of IACS UR E22. (Incorporates Notice No. 1)
4-9-3/3.7	Software Module	To incorporate the wording of IACS UR E22. (Incorporates Notice No. 1)
4-9-3/3.17 (New)	Other Terminology	To incorporate the wording of IACS UR E22. (Incorporates Notice No. 1)
4-9-3/5.1.1	System Security	To incorporate the wording of IACS UR E22. (Incorporates Notice No. 1)
4-9-3/5.3.1	General Requirements	To incorporate the wording of IACS UR E22. (Incorporates Notice No. 1)

<i>Part/Para. No.</i>	<i>Title/Subject</i>	<i>Status/Remarks</i>
4-9-3/7	Systems Configuration	To incorporate the wording of IACS UR E22. (Incorporates Notice No. 1)
4-9-3/Table 1	System Categories	To incorporate the wording of IACS UR E22. (Incorporates Notice No. 1)
4-9-3/9.1	General Principle	To incorporate the wording of IACS UR E22. (Incorporates Notice No. 1)
4-9-3/9.3	SDLC	To incorporate the wording of IACS UR E22. (Incorporates Notice No. 1)
4-9-3/9.3.2	Requirement and Design Phase	To incorporate the wording of IACS UR E22. (Incorporates Notice No. 1)
4-9-3/Table 2	SDLC Tests and Documentation	To incorporate the wording of IACS UR E22. (Incorporates Notice No. 1)
4-9-3A1/1.1	Quality Plan for Software	To incorporate the wording of IACS UR E22. (Incorporates Notice No. 1)
4-9-3A1/3.1	Software Requirements Specification (SRS)	To incorporate the wording of IACS UR E22. (Incorporates Notice No. 1)
4-9-3A1/3.3	Software Design Specification (SDS)	To incorporate the wording of IACS UR E22. (Incorporates Notice No. 1)
4-9-3A1/3.9	Failure Analysis for Safety Related Functions Only (For Example FMEA)	To incorporate the wording of IACS UR E22. (Incorporates Notice No. 1)
4-9-3A1/5.1	Quality Control in Production	To incorporate the wording of IACS UR E22. (Incorporates Notice No. 1)
4-9-3A1/5.9	Integration Tests	To incorporate the wording of IACS UR E22. (Incorporates Notice No. 1)
4-9-3A1/5.11	Fault Simulation	To incorporate the wording of IACS UR E22. (Incorporates Notice No. 1)
4-9-3A1/5.17	Evidence of Software Testing According to Quality Plan	To incorporate the wording of IACS UR E22. (Incorporates Notice No. 1)
4-9-3A1/7.1	Complete System Test	To incorporate the wording of IACS UR E22. (Incorporates Notice No. 1)
4-9-3A1/7.3	Onboard Integration Tests	To incorporate the wording of IACS UR E22. (Incorporates Notice No. 1)
4-9-3A1/9.5	Software Modification and Upgrades Record	To incorporate the wording of IACS UR E22. (Incorporates Notice No. 1)
4-9-3A2 (New)	On Board Use and Application of Computer-based Systems	To incorporate the wording of IACS UR E22. (Incorporates Notice No. 1)

Vessel Systems and Machinery

CONTENTS

CHAPTER 1	General	1
Section 1	Classification of Machinery	2
CHAPTER 2	Prime Movers	18
Section 1	Diesel Engines	27
	Appendix 1 – Plans and Data for Diesel Engines	76
	Appendix 2 – Definition of Stress Concentration Factors in Crankshaft Fillets.....	96
	Appendix 3 – Stress Concentration Factors and Stress Distribution at the Edge of Oil Drillings	98
	Appendix 4 – Guidance for Spare Parts	100
	Appendix 5 – Type Testing Procedure for Crankcase Explosion Relief Valves.....	103
	Appendix 6 – Type Testing Procedure for Crankcase Oil Mist Detection/Monitoring and Alarm Arrangements.....	109
	Appendix 7 – Alternative Method for Calculation of Stress Concentration Factors in the Web Fillet Radii of Crankshafts by Utilizing Finite Element Method	114
	Appendix 8 – Guidance for Evaluation of Fatigue Tests	121
	Appendix 9 – Guidance for Calculation of Surface Treated Fillets and Oil Bore Outlets	131
	Appendix 10 – Guidance for Calculation of Stress Concentration Factors in the Oil Bore Outlets of Crankshafts through Utilization of the Finite Element Method	143
Section 2	Turbochargers.....	147
Section 3	Gas Turbines	154
	Appendix 1 – Plans and Data for Gas Turbines.....	164
Section 4	Steam Turbines.....	166
	Appendix 1 – Guidance for Spare Parts	177

CHAPTER 3	Propulsion and Maneuvering Machinery	178
Section 1	Gears	188
	Appendix 1 – Rating of Cylindrical and Bevel Gears	198
	Appendix 2 – Guidance for Spare Parts	255
	Appendix 3 – Gear Parameters.....	256
Section 2	Propulsion Shafting.....	265
	Appendix 1 – Special Approval of Alloy Steel Used for Intermediate Shaft Material.....	293
Section 3	Propellers.....	296
Section 4	Steering Gears.....	310
Section 5	Thrusters.....	330
Section 6	Waterjets.....	340
Section 7	Propulsion Redundancy.....	342
Section 8	Podded Propulsion Units	350
Section 9	Contra-Rotating Propellers	357
CHAPTER 4	Boilers, Pressure Vessels and Fired Equipment.....	361
Section 1	Boilers and Pressure Vessels and Fired Equipment	364
	Appendix 1 – Rules for Design.....	385
CHAPTER 5	Deck and Other Machinery	415
Section 1	Anchor Windlass	416
CHAPTER 6	Piping Systems	421
Section 1	General Provisions.....	429
Section 2	Metallic Piping.....	437
Section 3	Plastic Piping	472
Section 4	Ship Piping Systems and Tanks	488
Section 5	Piping Systems for Internal Combustion Engines	526
Section 6	Piping Systems for Steam Plants	540
Section 7	Other Piping Systems	554
CHAPTER 7	Fire Safety Systems	563
Section 1	General Provisions.....	567
Section 2	Provisions for Specific Spaces	572
Section 3	Fire-extinguishing Systems and Equipment	592
Section 4	Requirements for Vessels Under 500 Gross Tons	624

CHAPTER 8	Electrical Systems	626
Section 1	General Provisions.....	633
Section 2	System Design.....	641
Section 3	Electrical Equipment	669
Section 4	Shipboard Installation and Tests	709
	Appendix 1 – Type Test Procedure for Plastic Cable Tray and Protective Casing.....	730
Section 5	Special Systems	734
CHAPTER 9	Automation	757
Section 1	General Provisions.....	765
Section 2	Essential Features Requirements.....	773
Section 3	Computer-based Systems	784
	Appendix 1 – Definitions and Notes Relating to SDLC and Hardware Test and Evidence Documentation in 4-9-3/Tables 2 and 3	794
	Appendix 2 – On Board Use and Application of Computer-based Systems	799
Section 4	Integrated Automation System	806
Section 5	ACC Notation.....	808
Section 6	ACCU Notation	816
Section 7	Vessels with Compact Propulsion Machinery Spaces.....	837
Section 8	Special Systems	838
Section 9	Equipment.....	842
Section 10	Installation, Tests and Trials	853
Section 11	Vessels Less Than 500 GT Having a Length Equal or Greater Than 20 m (65 ft)	856

PART
4

CHAPTER 1 General

CONTENTS

SECTION 1	Classification of Machinery	2
1	General	2
1.1	Organization of Part 4	2
1.3	Requirements for Classification	2
1.5	Classification Notations	3
1.7	Alternative Standards	4
1.9	Definitions	4
3	Certification of Machinery	5
3.1	Basic Requirements	5
3.3	Type Approval Program	6
3.5	Non-mass Produced Machinery	6
3.7	Details of Certification of Some Representative Products	6
5	Machinery Plans	6
5.1	Submission of Plans	6
5.3	Plans	6
7	Miscellaneous Requirements for Machinery	7
7.1	Construction Survey Notification	7
7.3	Machinery Equations	7
7.5	Astern Propulsion Power	7
7.7	Dead Ship Start	7
7.9	Inclinations	7
7.11	Ambient Temperature	7
7.13	Machinery Space Ventilation	8
7.15	Materials Containing Asbestos	8
9	Sea Trials	8
TABLE 1	Certification Details – Prime Movers	9
TABLE 2	Certification Details – Propulsion, Maneuvering and Mooring Machinery	9
TABLE 3	Certification Details – Electrical and Control Equipment	11
TABLE 4	Certification Details – Fire Safety Equipment	13
TABLE 5	Certification Details – Boilers, Pressure Vessels and Fired Equipment	13
TABLE 6	Certification Details – Piping System Components	14
TABLE 7	Design Angles of Inclination	15
TABLE 8	Ambient Temperatures for Unrestricted Service	17
FIGURE 1	Organization of Part 4	2

PART

4

CHAPTER 1 General

SECTION 1 Classification of Machinery

1 General

1.1 Organization of Part 4

Part 4 contains classification requirements for machinery. These requirements are organized in two broad segments: that specific to equipment, and that specific to systems. 4-1-1/Figure 1 shows the overall organization of Part 4.

**FIGURE 1
Organization of Part 4**

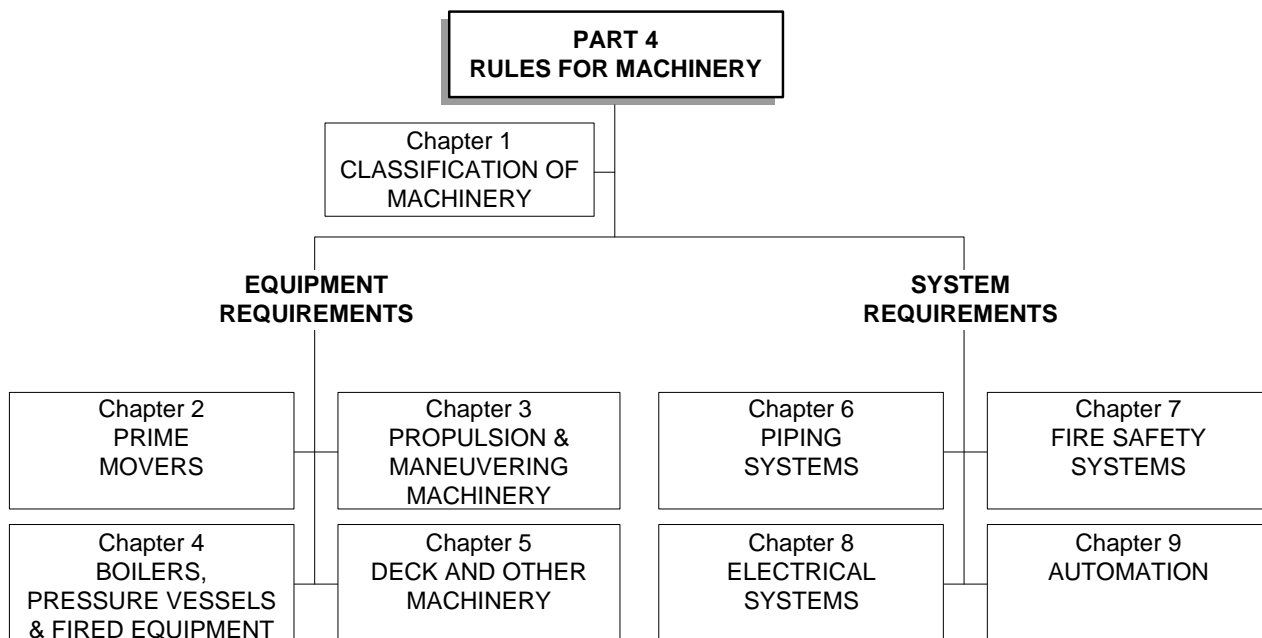

1.3 Requirements for Classification

1.3.1 Scopes of Part 4 and Part 5C or Part 5D

Part 4 provides the minimum requirements for machinery of self-propelled vessels. Compliance with Part 4 is a condition for classification of all such vessels, and for assigning the appropriate machinery class notations indicated in 4-1-1/1.5. Additional requirements for machinery, which are specific for each vessel type, are provided in Part 5C and Part 5D. Compliance with the provisions of Part 5C or Part 5D is a condition for assigning the vessel type class notation specified therein, such as **Oil Carrier, Passenger Vessel, Liquefied Gas Carrier**, etc.

1.3.2 Fundamental Intent of Machinery Rules

1.3.2(a) Propulsion and maneuvering capability. Part 4 of the Rules is intended to assure the propulsion and maneuvering capability of the vessel through specification of pertinent design, testing and certification requirements for propulsion, maneuvering and other equipment and their associated systems. See 4-1-1/Figure 1 for equipment and systems included in the scope.

1.3.2(b) Machinery hazards. Part 4 of the Rules is also intended to identify and address hazards associated with machinery aboard a vessel, particularly those hazards which are capable of causing personal injury, flooding, fire or pollution.

1.3.2(c) Cargo hazards. Hazards associated with cargoes carried (such as oil, dangerous goods, etc.) or to the specialized operations of the vessel (such as navigating in ice) are addressed in Part 5C, Part 5D, or Part 6, as applicable.

1.3.3 Application

Requirements in Part 4 are intended for vessels under construction; but they are to be applied to alterations made to existing vessels, as far as practicable.

1.5 Classification Notations

Classification notations are assigned to a vessel to indicate compliance with particular portions of the Rules. The following classification notations define compliance with specific requirements of the Rules for machinery:

AMS indicates that a vessel complies with all machinery requirements in Part 4, other than the requirements associated with the other classification notations below. **AMS** is mandatory for all self-propelled vessels.

ACC indicates that in a self-propelled vessel, in lieu of manning the propulsion machinery space locally, it is intended to monitor the propulsion machinery space and to control and monitor the propulsion and auxiliary machinery from a continuously manned centralized control station. Where such a centralized control station is installed, the provisions of Section 4-9-5 are to be complied with. Upon verification of compliance, **ACC** will be assigned.

ACCU or **ABCU** indicates that a self-propelled vessel is fitted with various degrees of automation and with remote monitoring and control systems to enable the propulsion machinery space to be periodically unattended and the propulsion control to be effected primarily from the navigation bridge. Where periodically unattended propulsion machinery space is intended, the provisions of Section 4-9-6 and Section 4-9-7 are to be complied with. Upon verification of compliance, **ACCU** or **ABCU** will be assigned.

APS indicates that a self-propelled vessel is fitted with athwartship thrusters. **APS** is optional for all self-propelled vessels fitted with such thrusters and signifies compliance with applicable requirements of Section 4-3-5.

PAS indicates that a non-self-propelled vessel is fitted with thrusters for the purpose of assisting the movement or maneuvering. **PAS** is only assigned when requested by the Owner and signifies compliance with applicable requirements of Section 4-3-5.

DPS-0, -1, -2, or -3 indicates that a vessel, self-propelled or non-self-propelled, is fitted with a dynamic positioning system. The numerals (**-0, -1, -2** or **-3**) indicates the degree of redundancy in the dynamic positioning system. **DPS** is assigned only when requested by the owners and signifies compliance with the *ABS Guide for Dynamic Positioning Systems*.

The above class notations, where preceded by the symbol ☒ (Maltese cross; e.g., ☒ **AMS**), signify that compliance with these Rules was verified by ABS during construction of the vessel. This includes survey of the machinery at the manufacturer's plant (where required), during installation on board the vessel and during trials.

Where an existing vessel, not previously classed by ABS, is accepted for class, these class notations are assigned without ☒.

1.7 Alternative Standards

Equipment, components and systems for which there are specific requirements in Part 4 may comply with requirements of an alternative standard, in lieu of the requirements in the Rules. This, however, is subject to such standards being determined by ABS as being not less effective than the Rules. Where applicable, requirements may be imposed by ABS in addition to those contained in the alternative standard to assure that the intent of the Rules is met. In all cases, the equipment, component or system is subject to design review, survey during construction, tests and trials, as applicable, by ABS for purposes of verification of its compliance with the alternative standard. The verification process is to be to the extent as intended by the Rules. See also 1-1-1/1.

1.9 Definitions

Definitions of terms used are defined in the chapter, sections or subsections where they appear. The following are terms that are used throughout Part 4.

1.9.1 Control Station

A location where controllers or actuator are fitted, with monitoring devices, as appropriate, for purposes of effecting desired operation of specific machinery.

Control Station is defined exclusively for purposes of Part 4, Chapter 7 “Fire Safety Systems,” as intended by SOLAS, in 4-7-1/11.21.

Centralized Control Station is used in Part 4, Chapter 9 “Automation” to refer to the space or the location where the following functions are centralized:

- Controlling propulsion and auxiliary machinery,
- Monitoring propulsion and auxiliary machinery, and
- Monitoring the propulsion machinery space.

1.9.2 Machinery Space

Machinery Space is any space that contains propulsion machinery, boilers, oil fuel units, steam and internal combustion engines, gas turbines, generators and major electrical machinery, oil filling stations, air conditioning and ventilation machinery, refrigerating machinery, stabilizing machinery or other similar machinery, including the trunks to the space. Machinery space is to include “machinery space of category A”, which, as defined in 4-7-1/11.15, is a space and trunks to that space which contains:

- Internal combustion machinery used for main propulsion; or
- Internal combustion machinery used for purposes other than main propulsion where such machinery has in the aggregate a total power output of not less than 375 kW (500 hp); or
- Any oil-fired boiler (including similar oil-fired equipment such as inert gas generators, incinerators, waste disposal units, etc.) or oil fuel unit (see definition in 4-7-1/11.19).

1.9.3 Essential Services

For definition of essential services, see 4-8-1/7.3.3.

1.9.4 Hazardous Area

Areas where flammable or explosive gases, vapors or dust are normally present or likely to be present are known as hazardous areas. Hazardous areas are, however, more specifically defined for certain machinery installations, storage spaces and cargo spaces that present such hazard, e.g.:

- Helicopter refueling facilities, see 4-8-4/27.3.3;
- Paint stores, see 4-8-4/27.3.3;
- Cargo oil tanks and other spaces of oil carriers; see 5C-1-7/31.5;

- Cargo tanks and other spaces of an offshore support vessel carrying hazardous and noxious liquid substances with flashpoints not exceeding 60°C (140°F) or carrying hazardous and noxious liquid substances which evolve substances with flashpoints not exceeding 60°C (140°F);
- Recovered oil tanks and other spaces of an offshore support vessel with oil spill response
- Ro-ro cargo spaces; see 5C-10-4/3.7.2.

1.9.5 Toxic or Corrosive Substances

Toxic Substances (solid, liquid or gas) are those that possess the common property of being liable to cause death or serious injury or to harm human health if swallowed or inhaled, or by skin contact.

Corrosive Substances (solid or liquid) are those, excluding saltwater, that possess in their original stage the common property of being able through chemical action to cause damage by coming into contact with living tissues, the vessel or its cargoes, when escaped from their containment.

1.9.6 Dead Ship Condition

Dead ship condition means a condition under which:

- i) The main propulsion plant, boilers and auxiliary machinery are not in operation due to the loss of the main source of electrical power, and
- ii) In restoring propulsion, the stored energy for starting the propulsion plant, the main source of electrical power and other essential auxiliary machinery is assumed to not be available.

1.9.7 Blackout

Blackout situation means the loss of the main source of electrical power resulting in the main and auxiliary machinery to be out of operation.

3 Certification of Machinery

3.1 Basic Requirements

The Rules define, to varying degrees, the extent of evaluation required for products, machinery, equipment and their components based on the level of criticality of each of those items. There are three basic evaluation constituents:

- Design review; type/prototype testing, as applicable;
- Survey during construction and testing at the plant of manufacture; and
- Survey during installation on board the vessel and at trials.

Where design review is required by the Rules, a letter will be issued by ABS upon satisfactory review of the plans to evidence the acceptance of the design. In addition to, or independent of, design review, ABS may require survey and testing of forgings, castings and component parts at the various manufacturers' plants, as well as survey and testing of the finished product. A certificate or report will be issued upon satisfactory completion of each survey to evidence acceptance of the forging, casting, component or finished product. Design review, survey and the issuance of reports or certificates constitute the *certification* of machinery.

Based on the intended service and application, some products do not require certification because they are not directly related to the scope of classification or because normal practices for their construction within the industry are considered adequate. Such products may be accepted based on the manufacturers' documentation on design and quality.

In general, surveys during installation on board the vessel and at trials are required for all items of machinery. This is not considered a part of the product certification process. There may be instances, however, where letters or certificates issued for items of machinery contain conditions which must be verified during installation, tests or trials.

3.3 Type Approval Program

Products that can be consistently manufactured to the same design and specification may be Type Approved under the ABS Type Approval Program. The ABS Type Approval Program is a voluntary option for the demonstration of the compliance of a product with the Rules or other recognized standards. It may be applied for at the request of the designer or manufacturer. The ABS Type Approval Program generally covers Product Type Approval (1-1-4/7.7.3), but is also applicable for a more expeditious procedure towards Unit-Certification, as specified in 1-1-4/7.7.2.

See the “ABS Type Approval Program” in Appendix 1-1-A3.

3.5 Non-mass Produced Machinery

Non-mass produced critical machinery, such as propulsion boilers, slow speed diesel engines, turbines, steering gears, and similar critical items are to be individually unit certified in accordance with the procedure described in 4-1-1/3.1. However, consideration will be given to granting Type Approval to such machinery in the category of Recognized Quality System (RQS). The category of Product Quality Assurance (PQA) will not normally be available for all products, and such limitations will be indicated in 4-1-1/Table 1 through 4-1-1/Table 6. In each instance where Type Approval is granted, in addition to quality assurance and quality control assessment of the manufacturing facilities, ABS will require some degree of product specific survey during manufacture.

3.7 Details of Certification of Some Representative Products

4-1-1/Table 1 through 4-1-1/Table 6 provide abbreviated certification requirements of representative machinery based on the basic requirements of the Rules for machinery. The tables also provide the applicability of the Type Approval Program for each of these machinery items.

For easy reference, the tables contain six product categories as follows:

- Prime movers
- Propulsion, maneuvering and mooring machinery
- Electrical and control equipment
- Fire safety equipment
- Boilers, pressure vessels, fired equipment
- Piping system components

5 Machinery Plans

5.1 Submission of Plans

Machinery and systems plans required by the Rules are generally to be submitted electronically by the manufacturer, designer or shipbuilder to ABS. However, hard copies will also be accepted. After review and approval of the plans, one copy will be returned to the submitter, one copy will be retained for the use of the ABS Surveyor, and one copy will be retained by ABS for record. Where so stated in the shipbuilding contract, the Owner may require the builder to provide copies of approved plans and related correspondence. A fee will be charged for the review of plans which are not covered by a contract of classification with the shipbuilder.

In general, all plans are to be submitted and approved before proceeding with the work.

5.3 Plans

Machinery plans required to be submitted for review and approval by ABS are listed in each of the sections in Part 4. In general, equipment plans are to contain performance data and operational particulars; standard of compliance where standards are used in addition to, or in lieu of, the Rules; construction details such as dimensions, tolerances, welding details, welding procedures, material specifications, etc.; and engineering calculations or analyses in support of the design. System plans are to contain a bill of material with material specifications or particulars, a legend of symbols used, system design parameters, and are to be in a schematic format. Booklets containing standard shipyard practices of piping and electrical installations are generally required to supplement schematic system plans.

7 Miscellaneous Requirements for Machinery

7.1 Construction Survey Notification

Before proceeding with the manufacture of machinery requiring test and inspection, ABS is to be notified that survey is desired during construction. Such notice is to contain all of the necessary information for the identification of the items to be surveyed.

7.3 Machinery Equations

The equations for rotating parts of the machinery in Part 4 of the Rules are based upon strength considerations only and their application does not relieve the manufacturer from responsibility for the presence of dangerous vibrations and other considerations in the installation at speeds within the operating range.

7.5 Astern Propulsion Power

7.5.1 General (1 July 2018)

Sufficient power for going astern is to be provided to secure proper control of the vessel in all normal circumstances. The astern power of the main propelling machinery is to be capable of maintaining in free route astern at least 70% of the ahead rpm corresponding to the maximum continuous ahead power. For main propulsion systems with reversing gears, controllable pitch propellers or electric propulsion drive, running astern is not to lead to overload of the propulsion machinery.

Main propulsion systems are to undergo tests to demonstrate the astern response characteristics. The tests are to be carried out at least over the maneuvering range of the propulsion system and from all control positions. A test plan is to be provided by the yard and accepted by the surveyor. If specific operational characteristics have been defined by the manufacturer these shall be included in the test plan. The ability of the machinery, including the blade pitch control system of controllable pitch propellers, to reverse the direction of thrust of the propeller in sufficient time, and so to bring the vessel to rest within a reasonable distance from maximum ahead service speed, is to be demonstrated and recorded during trials.

7.5.2 Steam Turbine Propulsion

Where steam turbines are used for main propulsion, they are to be capable of maintaining in free route astern at least 70% of the ahead revolutions for a period of at least 15 minutes. The astern trial is to be limited to 30 minutes or is to be in accordance with manufacturer's recommendation to avoid overheating of the turbine due to the effects of "windage" and friction.

7.7 Dead Ship Start

Means are to be provided to bring the machinery into operation from a "dead ship" condition, as defined in 4-1-1/1.9.6. See 4-8-2/3.1.3 and 4-8-4/1.13 for the required starting arrangements.

7.9 Inclinations

Machinery installations are to be designed to ensure proper operations under the conditions as shown in 4-1-1/Table 7.

7.11 Ambient Temperature

For vessels of unrestricted service, ambient temperature, as indicated in 4-1-1/Table 8, is to be considered in the selection and installation of machinery, equipment and appliances. For vessels of restricted or special service, the ambient temperature appropriate to the special nature is to be considered.

7.13 Machinery Space Ventilation

Suitable ventilation is to be provided for machinery spaces so as to simultaneously allow for crew attendance and for engines, boilers and other machinery to operate at rated power in all weather conditions, including heavy weather. The main propulsion machinery space is to be provided with mechanical means of ventilation.

The supply of air is to be provided through ventilators which can be used in all weather conditions. In general, ventilators necessary to continuously supply the main propulsion machinery space and the immediate supply to the emergency generator room are to have coamings of sufficient height to eliminate the need to have closing arrangements. See 3-2-17/9.3.

However, where due to the vessel size and arrangement this is not practicable, lesser heights for machinery space and emergency generator room ventilator coamings may be accepted with provision of weathertight closing appliances in accordance with 3-2-17/9.3.3 in combination with other suitable arrangements to ensure an uninterrupted and adequate supply of ventilation to these spaces. See also 4-7-2/1.9.5 and 4-7-2/1.9.7.

7.15 Materials Containing Asbestos

Installation of materials which contain asbestos is prohibited.

9 Sea Trials

A final underway trial is to be made of all machinery, steering gear, anchor windlass, stopping and maneuvering capability, including supplementary means for maneuvering, if any. Insofar as practicable, the vessel is to be ballasted or otherwise arranged to simulate fully laden condition so as to allow propulsion machinery to discharge its rated power. The entire machinery installation is to be operated in the presence of the Surveyor in order to demonstrate its reliability and sufficiency to function satisfactorily under operating conditions and its freedom from dangerous vibration and other detrimental operating phenomena at speeds within the operating range. All automatic controls, including tripping of all safety protective devices that affect the vessel's propulsion system, are to be tested under way or alongside the pier, to the satisfaction of the Surveyor. References are also to be made to the following for more detailed requirements:

- Steering gear trial: 4-3-4/21.7
- Anchor windlass trial: 4-5-1/9
- Remote propulsion control and automation trial: 4-9-10/5
- Shipboard trials for diesel engines: 4-2-1/15

The viscosity of the fuel used on the sea trial will be entered in the classification report.

Based on the sea trials, the following information is to be provided on board:

- Stopping time (see also 4-1-1/7.5),
- Vessel headings and distances recorded on sea trials, and
- For vessels with multiple propellers, ability to navigate and maneuver with one or more propellers inoperative.

Reference may be made to IMO Resolution A.209(VII) *Recommendation on Information to be Included in the Maneuvering Booklet* and IMO Resolution A.601(15) *Recommendation on the Provision and the Display of Maneuvering Information on board ships*.

TABLE 1
Certification Details – Prime Movers

<i>Prime Movers</i>	<i>ABS Approval Tier</i>	<i>Rule Reference</i>
Section 1: Diesel Engines		
1. Diesel engines \geq 100 kW (135 hp), intended for propulsion and aux. services essential for propulsion, maneuvering and safety of the vessel, or required by optional class notation	4/5	4-2-1/1.1, 4-2-1/13.1–13.9, 4-2-1/13.13, 4-2-1/15
2. Diesel engines that are mass produced per 4-2-1/13.11	4/5	4-2-1/13.11, 4-2-1/13.13, 4-2-1/15
3. Diesel engines < 100 kW (135 hp)	1	4-2-1/1.1
4. Diesel engines \geq 100 kW (135 hp), intended for services not essential for propulsion and aux. services for propulsion, maneuvering and safety of the vessel	1	4-2-1/1.1, 4-2-1/7
Section 2: Turbochargers		
5. Turbochargers for engines \geq 100 kW (135 hp), intended for propulsion and aux. services essential for propulsion, maneuvering and safety of the vessel	5	4-2-2/1.1, 4-2-2/5.7, 4-2-2/11.1–11.5
6. Turbochargers that are mass produced per 4-2-2/11.3.2(b)	4/5	4-2-2/5.7, 4-2-2/11.1–11.5
7. Turbochargers for engines < 100 kW (135 hp)	1	4-2-2/1.1
Section 3: Gas Turbines		
8. Gas turbines \geq 100 kW (135 hp), intended for propulsion and aux. services essential for propulsion, maneuvering and safety of the vessel	5	4-2-3/1.1, 4-2-3/5.7, 4-2-3/13.1–13.5
9. Gas turbines that are mass produced per 4-2-3/13.3.2(b)	4	4-2-3/5.7, 4-2-3/13.1–13.5
10. Gas turbines < 100 kW (135 hp)	1	4-2-3/1.1
11. Gas turbines \geq 100 kW (135 hp), intended for services not essential for propulsion and aux. services for propulsion, maneuvering and safety of the vessel	1	4-2-3/1.1, 4-2-3/7
Section 4: Steam Turbines		
12. Steam turbines \geq 100 kW (135 hp), intended for propulsion and aux. services essential for propulsion, maneuvering and safety of the vessel	5	4-2-4/1.1, 4-2-4/13.1–13.5
13. Steam turbines that are mass produced per 4-2-4/13.3.2(b)	4	4-2-4/13.1–13.5
14. Steam turbines < 100 kW (135 hp)	1	4-2-4/1.1
15. Steam turbines \geq 100 kW (135 hp), intended for services not essential for propulsion and aux. services for propulsion, maneuvering and safety of the vessel	1	4-2-4/1.1, 4-2-4/7

TABLE 2
Certification Details – Propulsion, Maneuvering and Mooring Machinery

<i>Propulsion, Maneuvering and Mooring Machinery</i>	<i>ABS Approval Tier</i>	<i>Rule Reference</i>
Section 1: Propulsion Shafting		
1. Propulsion shafts, couplings, coupling bolts	5	4-3-2/3.1-3.7, 4-3-2/3.7.2(b), 4-3-2/9, 4-3-2/5.19
2. Cardan shafts	4/5	4-3-2/5.21, 4-3-2/5.19
3. Coupling bolts constructed to a recognized standard	1	N/A
Section 2: Gears and Clutches		
4. Gears and clutches \geq 5590 kW (7500 hp)	5	4-3-1/9.7.1
5. Gears and clutches \geq 100 kW (135 hp)	4/5	4-3-1/1.1, 4-3-1/9.7.2(c)
6. Gears and clutches $<$ 100 kW (135 hp)	1	4-3-1/9.7.2(d)
Section 3: Propellers		
7. Propellers, fixed and controllable pitch	5	4-3-3/7.3
8. Propulsion thrusters	4/5	4-3-5
9. Podded propulsion units	5	4-3-7 and 3-2-14/25
Section 4: Steering		
10. Steering gears	5	4-3-4/19.1–19.7
11. Thrusters with optional notations (APS , DPS or PAS notation)	4/5	4-3-5/1.3 and 4-3-5/13, <i>DPS Guide</i>
12. Other thrusters 375 kW (500 hp) or less	1	4-3-5/3.3.2
Section 5: Anchoring and Mooring		
13. Anchor windlass	4/5	4-5-1/7
14. Mooring winches	1	4-5-1/1.3

TABLE 3
Certification Details – Electrical and Control Equipment

<i>Electrical and Control Equipment</i>	<i>ABS Approval Tier</i>	<i>Rule Reference</i>
1. Generators and motors for essential services ≥ 100 kW (135 hp)	4/5	4-8-3/3, 4-8-5/3.13.1 (high voltage)
2. Motors ≥ 100 kW (135 hp) for LNG cargo or vapor handling services. (See 5C-8-10/2.12)	4/5	5C-8-10/2.12, 4-8-3/3.17
3. Generators and motors for essential services < 100 kW (135 hp)	1	4-8-3/3.1
4. Motors < 100 kW (135 hp) for LNG cargo or vapor handling services. (See 5C-8-10/2.12)	1	4-8-3/3
5. Propulsion generators and motors	5	4-8-3/3, 4-8-5/5.17.5, 4-8-5/3.13.1 (high voltage)
6. Switchboards (propulsion, main and emergency)	4/5	4-8-3/5.11.1, 4-8-5/3.13.2 (high voltage)
7. Motor controllers for essential services (See 4-8-1/7.3.3) ≥ 100 kW (135 hp) and for services indicated in 4-8-3/Table 7 ≥ 100 kW (135 hp)	4/5	4-8-3/5.11.1
8. Motor controllers ≥ 100 kW (135 hp) for LNG cargo or vapor handling services. (See 5C-8-10/2.12)	4/5	5C-8-10/2.12
9. Motor control centers including motor controller for essential services (See 4-8-1/7.3.3) ≥ 100 kW (135 hp) and for services indicated in 4-8-3/Table 7 of aggregate load ≥ 100 kW (135 hp)	5	4-8-3/5.11.1
10. Motor controllers for steering gear	5	4-8-3/5.11.1
11. Motor control centers ≥ 100 kW (135 hp) for LNG cargo or vapor handling services. (See 5C-8-10/2.12)	4/5	4-8-3/5.11.1
12. Battery charger units of 25 kW and over, and discharging boards for essential services (see 4-8-1/7.3.3), emergency and transitional source of power (See 4-8-3/5.9)	4/5	4-8-3/5.11.1
13. Uninterruptible power system (UPS) units of 50 kVA and over for essential services (see 4-8-1/7.3.3), and for services indicated in 4-8-3/Table 7, emergency source or transitional source of power	4/5	4-8-3/5.11.1
14. Distribution boards associated with the charging or discharging of the battery system for emergency source and transitional source of power	4/5	4-8-3/5.11.1
15. Distribution boards associated with the uninterruptible power system (UPS) units of 50 kVA and over for essential services (see 4-8-1/7.3.3), for services indicated in 4-8-3/Table 7 and emergency source or transitional source of power	4/5	4-8-3/5.11.1
16. Power transformers for Essential Service and for emergency source of power and converters of low voltage	1	4-8-3/7, 4-8-3/8
17. Non-sparking fans (See 4-8-3/11)	2	4-8-3/11
18. Plastic Cable Tray and Protective Casing (See 4-8-4/21.9.4 and Appendix 4-8-4A1)	2	4-8-4/21.9.4, 4-8-4A1
19. Power transformers and converters for high voltage systems exceeding 100 kVA	5	4-8-5/3.7.5(e)
20. Cables	1	4-8-5/3.13.3 (high voltage), 4-8-3/9.17
21. Propulsion cables	4/5	4-8-5/5.17.11
22. Circuit breakers and fuses	1	4-8-3/5.3.3, 4-8-3/5.3.4
23. Certified safe equipment	2	4-8-3/13.1
24. Governors	2	4-2-1/7.3.3iii), 4-9-8/13
25. Cable penetration devices	2	4-8-1/5.3.1
26. Semiconductor converters for propulsion	4/5	4-8-5/5.17.8
27. Generator prime mover remote control system	4/5	4-9-8/13
28. Remote auxiliary machinery control system	4/5	4-9-8/13

TABLE 3 (continued)
Certification Details – Electrical and Control Equipment

<i>Electrical and Control Equipment</i>	<i>ABS Type Approval Tier</i>	<i>Rule Reference</i>
29. Centralized control and monitoring console	4/5	4-9-8/13
30. Control, monitoring and safety system devices, including computers, programmable logic controllers, etc., for DPS, ACC and ACCU notations	4/5	4-9-3/9.3.4, 4-9-3/11.9, 4-9-8/13.1
31. Complete assembly or subassembly units for DPS, ACC and ACCU notations	4/5	4-9-3/9.3.4, 4-9-3/11.9, 4-9-8/13.1
32. Steering control system	5	4-3-4/13, 4-9-3/9.3.4, 4-9-3/11.9
33. Boiler control system (4-9-1/7.3)	5	4-4-1/11.5, 4-9-3/9.3.4, 4-9-3/11.9
34. CPP control system	5	4-9-3/9.3.4, 4-9-3/11.9
35. Computer-based System (Cat. II or III) for other than DPS, ACC or ACCU notation	5	4-9-3/9.3.4, 4-9-3/11.9

TABLE 4
Certification Details – Fire Safety Equipment

<i>Fire Safety Equipment</i>	<i>ABS Approval Tier</i>	<i>Rule Reference</i>
Section 1: Fire Detection and Alarm System Components		
1. Fire detection and alarm system components	2	4-7-3/11
Section 2: Fixed Fire Extinguishing System Components		
2. Fixed fire extinguishing system components	2	4-7-3/3
3. Fixed gas systems	2	4-7-3/3
4. Fixed foam systems	2	4-7-3/5 (IMO MSC/circ. 1165R)
5. Fixed water spray and water-mist systems	2	4-7-3/7
Section 3: Fireman’s Outfit, Hoses, and Portable Extinguishers		
6. Fireman’s outfit ⁽¹⁾	3	4-7-3/15.5
7. Fire hoses ⁽¹⁾	3	4-7-3/1.13
8. Portable fire extinguishers ⁽¹⁾	3	4-7-3/15.1

Note:

- 1 Type approval by flag Administration is acceptable in lieu of ABS Tier requirements.

TABLE 5
Certification Details – Boilers, Pressure Vessels and Fired Equipment

<i>Boilers, Pressure Vessels and Fired Equipment</i>	<i>ABS Approval Tier</i>	<i>Rule Reference</i>
Section 1: Group I		
1. Group I boilers and pressure vessels	5	4-4-1/7
Section 2: Group II		
2. Fired Pressure Vessels	4/5	4-4-1/7
3. Non-fired pressure vessels	4/5	4-4-1/7
Section 3: Inert Gas Generators & Incinerators		
4. Inert gas generators, incinerators	2	4-4-1/1, 4-4-1/15

TABLE 6
Certification Details – Piping System Components

<i>Piping System Components</i>	<i>ABS Approval Tier</i>	<i>Rule Reference</i>
1. Pumps related to propulsion diesel engines (bore >300 mm) (11.8 in.) and gas turbines and gears—fuel, cooling water, lube. Oil services	4/5	4-6-1/7.3.1, 4-6-1/7.5.3
2. Pumps related to propulsion steam plant and gears—fuel oil, lube. Oil, condensate, main circulating, feed water services, vacuum pumps for main condenser	4/5	4-6-1/7.3.1, 4-6-1/7.5.3
3. Hydraulic pumps of steering gears, controllable pitch propellers, anchor windlass	4/5	4-6-1/7.3.1, 4-6-1/7.5.3
4. Pumps for fire main, emergency fire pumps, other fire service (fixed water-based, sprinkler, foam), ballast, bilge, liquid cargoes, pumps associated with inert gas	4/5	4-6-1/7.3.1, 4-6-1/7.5.3
5. Air compressors	1	4-6-5/9.3.3
6. Gas Compressors associated with liquefied gas carriers	4/5	5C-8-5/13.1.3
7. Refrigerated Cargo Compressor	5	6-2-6/25.1
8. Liquefied Gas Cargo Pumps	4/5	4-6-1/7.3.1v), 5C-8-5/13.1.3 (IACS)
9. Steel pipes, classes I and II (except hydraulic piping)	4/5	4-6-1/7.1.1, 4-6-1/7.5.1, 5C-8-5/12.1
10. Steel pipes, class III	1	4-6-1/7.1.1, 4-6-1/7.5.1, 5C-8-5/12.1
11. Pipe fittings—flanges, elbows, tees, flexible joints, etc., and valves; classes I & II designed to a recognized standard	4/5	4-6-1/7.1.1, 4-6-1/7.5.2, 5C-8-5/12.1, 5C-8-5/13.1
12. Pipe fittings—flanges, elbows, tees, flexible joints, etc., and valves; class III	2	4-6-1/7.1.1, 4-6-1/7.5.2, 5C-8-5/12.1, 5C-8-5/13.1
13. Level 1 and 2 Plastic pipes and pipe joints with ISO9001 certifications	2	4-6-3/9, IACS UR P4
14. Level 1 and 2 Plastic pipes and pipe joints w/o ISO9001 certifications	5	4-6-3/9, IACS UR P4
15. Level 3 Plastic pipes and pipe joints	1	4-6-3/9, IACS UR P4
16. Hoses (Does not cover fire hoses. For fire hoses, see 4-1-1/Table 4)	2	4-6-2/5.7
17. Vent heads, pressure vacuum valves	2	4-6-2/7
18. Gauges, detectors and transmitters	2	4-6-2/9.11
19. Fluid power cylinders and systems, including valve actuators, excluding steering actuators	2	4-6-7/3.5

TABLE 7
Design Angles of Inclination

	<i>Angle of Inclination, degrees ⁽¹⁾</i>			
	<i>Athwartship</i>		<i>Fore-and-Aft</i>	
Installations, components	Static	Dynamic	Static	Dynamic
Propulsion and auxiliary machinery	15	22.5	5 ⁽⁴⁾	7.5
Safety equipment				
Emergency power installation ⁽³⁾	22.5	22.5	10	10
Emergency fire pumps and their drives	22.5	22.5	10	10
Switchgear				
Electrical and electronic appliances and control systems	22.5 ⁽²⁾	22.5 ⁽²⁾	10	10

Notes

- 1 Athwartship and fore-and-aft inclinations occur simultaneously.
- 2 Up to an angle of inclination of 45 degrees, switches and controls are to remain in their last set position.
- 3 In vessels designed for carriage of liquefied gases and of chemicals, the emergency power installation is to remain operable with the vessel flooded to its permissible athwartship inclination up to a maximum of 30 degrees.
- 4 Where the length of the vessel exceeds 100 m (328 ft), the fore-and-aft static angle of inclination may be taken as $500/L$ degrees, where L is the length of the vessel in meters ($1640/L$ degrees, where L is the length of the vessel in feet), as defined in 3-1-1/3.1.

TABLE 8
Ambient Temperatures for Unrestricted Service

Air		
<i>Installations, Components</i>	<i>Location, Arrangement ^(1, 2)</i>	<i>Temperature Range (°C)</i>
Machinery and electrical installations	Enclosed Spaces – General	0 to +45
	Components mounted on machinery associated with high temperature	According to specific machinery and installation
	In spaces subject to higher temperature (details to be submitted)	According to the actual maximum ambient temperature
	In spaces with temperature lower than +45°C (details to be submitted)	According to the actual ambient temperature subject to minimum +40
	Open Deck	-25 to +45
Water		
<i>Coolant</i>		<i>Temperature (°C)</i>
Seawater		+32

Notes:

- 1 Electronic equipment is to be suitable for operations up to 55°C.
- 2 For environmentally controlled spaces, see 4-8-3/1.17.2.

CONTENTS

SECTION 1	Diesel Engines	27
1	General	27
1.1	Application	27
1.3	Definitions	27
1.5	Increased Power Rating	28
1.7	Ambient Reference Conditions	28
1.9	Plans and Particulars to be Submitted	28
3	Materials	31
3.1	Material Specifications and Tests	31
3.3	Alternative Materials and Tests	31
5	Design	31
5.1	Bedplate/Crankcase	31
5.3	Crankcase Doors	31
5.5	Cylinders and Covers, Liners and Pistons	31
5.7	Securing of Nuts	32
5.9	Crankshafts	32
5.11	Shaft Couplings and Clutches	47
7	Engine Appurtenances	47
7.1	Explosion Relief Valves	47
7.2	Protection Against Crankcase Explosions	49
7.3	Governors and Overspeed Protection	51
7.5	Governors and Overspeed Protection for Engines Driving Generators	51
7.7	Materials other than Steel on Engine, Turbine and Gearbox Installations	53
7.9	Auxiliary Blowers	53
7.11	Fire Extinguishing System for Scavenge Manifold	53
7.13	Warning Notices	53
7.15	Jacket Drain and Overpressure Protection	54
7.17	Monitoring	54
7.19	Engine Turning Gear	54
9	Piping Systems for Diesel Engines	54
11	Installation of Diesel Engines	54
11.1	Seating Arrangements for Diesel Engines	54
11.3	Metal Chocks	54
11.5	Cast Resin Chocks	54
11.7	Resilient Mountings	55
11.9	Hot Surfaces	55

13	Testing, Inspection and Certification of Diesel Engines	55
13.1	Material and Nondestructive Tests	55
13.3	Hydrostatic Tests of Diesel Engine Components	55
13.5	Relief and Safety Valves	55
13.6	Manufacturer's Quality Control	55
13.7	Type Tests of Diesel Engines	58
13.9	Shop Tests of Internal Combustion, I.C. Engines	64
13.11	Type Tests of Mass-produced Diesel Engines	68
13.13	Certification of Diesel Engine	70
15	Shipboard Trials of Diesel Engines	70
15.1	Engines Driving Fixed Pitch Propellers or Impellers	70
15.3	Engines Driving Controllable Pitch Propellers	71
15.5	Engines Driving Propulsion Generators, Main Power Supply Generators and/or Emergency Generators	71
15.6	Propulsion Engines also Driving Power Take Off (PTO) Generator	71
15.7	Engines Driving Auxiliaries	71
15.9	Engines Burning Residual Fuel Oil or Other Special Fuel Oils	71
15.11	Torsional Vibration Barred Speed Range	71
TABLE 1	Required Material and Nondestructive Tests of Diesel Engine Parts	73
TABLE 2	Test Pressures for Parts of Internal-combustion Engines	75
FIGURE 1	Crank Throw for In Line Engine	33
FIGURE 2	Crank Throw for Vee Engine with 2 Adjacent Connecting-Rods	33
FIGURE 3	Reference Area of Crank Web Cross Section	34
FIGURE 4	Crankpin Section Through the Oil Bore	35
FIGURE 5	Crank Dimensions	40
FIGURE 6	Crank Throw of Semi-built Crankshaft	45
FIGURE 7	Limiting Curves for Loading 4-stroke Diesel Engines Step by Step from No-load to Rated Power as Function of the Brake Mean Effective Pressure	52
FIGURE 8	Type Test Power/Speed Diagram	64
SECTION 1	Appendix 1 – Approval of Diesel Engines	76
1	Scope	76
3	Definitions	76
5	Overview	76
5.1	Approval Process	76
5.3	Document Flow for Diesel Engines	77
5.5	Approval of Diesel Engine Components	78
5.7	Submission Format of Documentation	78
7	Type Approval Process	78
7.1	Documents for Information Table 1	78
7.3	Documents for Approval or Recalculation Table 2	78
7.5	Design Approval/Appraisal (DA)	78

	7.7	Type Approval Test.....	78
	7.9	Type Approval Certificate	78
	7.11	Design Modifications.....	78
	7.13	Type Approval Certificate Renewals.....	78
	7.15	Validity of Type Approval Certificate	79
	7.17	Document Review and Approval	79
9		Certification Process	79
	9.1	Document Development for Production	79
	9.3	Documents to be Submitted for Inspection and Testing	79
	9.5	Alternative Execution	80
	9.7	Manufacturer Approval	80
	9.9	Document Availability	80
	9.11	Engine Assembly and Testing	80
		ANNEX 1 – Glossary	84
		ANNEX 2 – Representative Document Flow Diagrams	87
		ANNEX 3 – Internal Combustion Engine Approval Application Form and Data Sheet	89
		ANNEX 4 – Tabular Listing of Licensor’s and Licensee’s Drawing and Data.....	94
		ANNEX 5 – Sample Template for Confirmation of the Licensor’s Acceptance of Licensee’s Modifications	95
		TABLE 1 Documentation to be Submitted for Information, as Applicable.....	81
		TABLE 2 Documentation to be Submitted for Approval, as Applicable.....	82
		TABLE 3 Documentation for the Inspection of Components and Systems	83
		FIGURE 1 Type Approval Document Flow.....	87
		FIGURE 2 Engine Certificate Document Flow.....	88
SECTION 1		Appendix 2 – Definition of Stress Concentration Factors in Crankshaft Fillets	96
SECTION 1		Appendix 3 –Stress Concentration Factors and Stress Distribution at the Edge of Oil Drillings.....	98
SECTION 1		Appendix 4 – Guidance for Spare Parts	100
	1	General	100
	3	Spare Parts for Main Propulsion Diesel Engines.....	100
	5	Spare Parts for Auxiliary Diesel Engines	101

SECTION 1	Appendix 5 – Type Testing Procedure for Crankcase Explosion Relief Valves	103
1	Scope	103
3	Recognized Standards.....	103
5	Purpose.....	103
7	Test Facilities	103
9	Explosion Test Process	104
11	Valves to be Tested	105
13	Method	105
	13.1 General Requirements	105
	13.3 Stages of Testing	105
15	Assessment and Records	106
17	Design Series Qualification.....	107
	17.1 General.....	107
	17.3 Flame Arrester.....	107
	17.5 Valves of Larger Sizes than Have Been Satisfactorily Tested	107
	17.7 Valves of Smaller Sizes than Have Been Satisfactorily Tested	107
19	Reporting	108
21	Acceptance	108

SECTION 1	Appendix 6 – Type Testing Procedure for Crankcase Oil Mist Detection and Alarm Equipment.....	109
1	Scope	109
3	Recognized Environmental Test Standards	109
5	Purpose.....	109
7	Test Facilities	109
9	Equipment Testing	110
	9.1 For the Alarm/Monitoring Panel.....	110
	9.3 For the Detectors.....	110
11	Functional Tests.....	110
13	Detectors and Alarm Equipment to be Tested.....	111
15	Method	111
17	Assessment	112
19	Design Series Qualification.....	112
21	Reporting	112
23	Acceptance	113

SECTION 1	Appendix 7 – Alternative Method for Calculation of Stress Concentration Factors in the Web Fillet Radii of Crankshafts by Utilizing Finite Element Method	114
1	General	114
3	Model Requirements.....	114
	3.1 Element Mesh Recommendations.....	114
	3.3 Materials.....	115
	3.5 Element Mesh Quality Criteria.....	116

5	Load Cases	116
5.1	Torsion.....	116
5.3	Pure Bending (4 Point Bending)	117
5.5	Bending With Shear Force (3 Point Bending)	118
FIGURE 1	Oil Bore Proximity to Fillet.....	115
FIGURE 2	Boundary and Load Conditions for the Torsion Load Case	117
FIGURE 3	Boundary and Load Conditions for the Pure Bending Load Case	118
FIGURE 4	Boundary and Load Conditions for the 3-Point Bending Load Case of an Inline Engine.....	119
FIGURE 5	Load Applications for In-line and V-type Engines	120

SECTION 1 Appendix 8 – Guidance for Evaluation of Fatigue Tests..... 121

1	Introduction	121
1.1	Small Specimen Testing	121
1.3	Full-size Crank Throw Testing	121
3	Evaluation of Test Results	121
3.1	Principles	121
5	Small Specimen Testing	122
5.1	Determination of Bending Fatigue Strength.....	122
5.3	Determination of Torsional Fatigue Strength	123
5.5	Other Test Positions	123
5.7	Correlation of Test Results	123
7	Full Size Testing	123
7.1	Hydraulic Pulsation	123
7.3	Resonance Tester	124
7.5	Use of Results and Crankshaft Acceptability	125
9	Use of Existing Results for Similar Crankshafts	126
11	Calculation Technique	127
11.1	Staircase Method.....	127
11.3	Modified Staircase Method	127
11.5	Calculation of Sample Mean and Standard Deviation.....	127
11.7	Confidence Interval for Mean Fatigue Limit	129
11.9	Confidence Interval for Standard Deviation	129
FIGURE 1	Specimen Locations in a Crank Throw	122
FIGURE 2	An Example of Testing Arrangement of the Resonance Tester for Bending Loading.....	124
FIGURE 3	An Example of Testing Arrangement of the Resonance Tester for Torsion Loading with Double Crank Throw Section	125
FIGURE 4	Student's <i>t</i> -Distribution	129
FIGURE 5	Chi-square Distribution	130

SECTION 1	Appendix 9 – Guidance for Calculation of Surface Treated Fillets and Oil Bore Outlets.....	131
1	Introduction	131
3	Surface Treatment	131
3.1	Surface Treatment Methods	131
5	Calculation Principles.....	132
5.1	Evaluation of Local Fillet Stresses.....	132
5.3	Evaluation of Oil Bore Stresses.....	134
5.5	Acceptability Criteria.....	136
7	Induction Hardening.....	136
7.1	Local Fatigue Strength	137
9	Nitriding.....	138
9.1	Local Fatigue Strength	139
11	Cold Forming	140
11.1	Stroke Peening by Means of a Ball	140
11.3	Cold Rolling.....	142
TABLE 1	The Influence of Tensile Residual Stresses at a Given Distance from the End of the Hardening Towards the Fillet.....	138
FIGURE 1	Stresses as Functions of Depth, General Principles	132
FIGURE 2	Bending SCF in the Crankpin Fillet as a Function of Depth.....	133
FIGURE 3	Torsional SCF in the Crankpin Fillet as a Function of Depth.....	134
FIGURE 4	Stresses and Hardness in Induction Hardened Oil Holes	135
FIGURE 5	Typical Hardness as a Function of Depth.....	136
FIGURE 6	Residual Stresses along the Surface of a Pin and Fillet.....	137
FIGURE 7	Sketch of the Location for the Artificial Transition Point in the Depth Direction	140
FIGURE 8	Working and Residual Stresses below the Stroke-peened Surface.....	141

SECTION 1	Appendix 10 – Guidance for Calculation of Stress Concentration Factors in the Oil Bore Outlets of Crankshafts through Utilization of the Finite Element Method	143
1	General	143
3	Model Requirements.....	143
3.1	Element Mesh Recommendations.....	143
3.3	Material.....	144
3.5	Element Mesh Quality Criteria.....	144
5	Load Cases and Assessment of Stress.....	144
5.1	Torsion	144
5.3	Bending	145

FIGURE 1	Boundary and Load Conditions for the Torsion Load Case.....	145
FIGURE 2	Boundary and Load Conditions for the Pure Bending Load Case.....	146

SECTION 2	Turbochargers	147
1	General	147
1.1	Application	147
1.3	Definitions.....	147
1.5	Plans and Particulars to be Submitted.....	147
3	Materials.....	148
3.1	Material Specifications and Purchase Orders.....	148
3.3	Category A and B Turbochargers	148
3.5	Category C Turbochargers	148
3.7	Alternative Material Test Requirements.....	149
5	Design Requirements and Corresponding Type Testing	149
5.1	General.....	149
5.3	Containment	149
5.5	Disc-shaft Shrinkage Fit (applicable to turbochargers of category C)	150
5.7	Type Testing (applicable to category B and C turbochargers).....	150
7	Piping Systems for Turbochargers	150
8	Alarms and Monitoring	150
9	Installation of Turbochargers	151
9.1	Air Inlet	151
9.3	Hot Surfaces.....	151
9.5	Pipe and Duct Connections	151
11	Testing, Inspection and Certification of Turbochargers	151
11.1	Shop Inspection and Tests	151
11.3	Certification of Turbochargers	152
11.5	Engine and Shipboard Trials	153
13	Spare Parts	153

SECTION 3	Gas Turbines	154
1	General	154
1.1	Application	154
1.3	Definitions.....	154
1.5	Plans and Particulars to be Submitted.....	154
3	Materials.....	156
3.1	Material Specifications and Tests	156
3.3	Alternative Materials and Tests	156
5	Design.....	157
5.1	Rotors and Blades	157
5.3	Operation Above the Rated Speed and Power.....	157
5.5	Overhaul Interval	157
5.7	Type Test Data	157
5.9	Casing	157

7	Gas Turbine Appurtenances	158
7.1	Overspeed Protective Devices	158
7.3	Operating Governors for Propulsion Gas Turbines	158
7.5	Operating Governors for Turbines Driving Electric Generators	158
7.7	Safety Systems and Devices	159
7.9	Hand Trip Gear	160
7.11	Air-intake Filters and Anti-icing	160
7.13	Silencers	160
9	Piping and Electrical Systems for Gas Turbines	161
11	Installation of Gas Turbines	161
11.1	Pipe and Duct Connections	161
11.3	Intake and Exhaust	161
11.5	Hot Surfaces	161
13	Testing, Inspection and Certification of Gas Turbines	161
13.1	Shop Inspection and Tests	161
13.3	Certification of Gas Turbines	162
13.5	Shipboard Trials	163
15	Spare Parts	163
TABLE 1 List of Alarms and Shutdowns		160

SECTION 3 Appendix 1 – Plans and Data for Gas Turbines..... 164

SECTION 4 Steam Turbines 166

1	General	166
1.1	Application	166
1.3	Definitions	166
1.5	Plans and Particulars to be Submitted	167
3	Materials	168
3.1	Material Specifications and Tests	168
3.3	Alternative Materials and Tests	168
5	Design	168
5.1	Casings	169
5.3	Rotor Shafts	169
5.5	Blades	170
5.7	Discs or Drums	170
7	Steam Turbine Appurtenances	172
7.1	Overspeed Protective Devices	172
7.3	Operating Governors for Propulsion Turbines	172
7.5	Operating Governors for Turbines Driving Electric Generators	173
7.7	Hand and Automatic Tripping	173
7.9	Shaft Turning Gear	174
7.11	Overpressure Protection	174
9	Piping Systems for Steam Turbines	174

11	Installation of Steam Turbines	174
11.1	Exhaust Steam to Turbine	174
11.3	Extraction of Steam	174
11.5	Pipe and Duct Connections	174
11.7	Hot Surfaces	174
13	Testing, Inspection and Certification of Steam Turbines	175
13.1	Shop Inspection and Tests	175
13.3	Certification of Steam Turbines	175
13.5	Shipboard Trials.....	176
SECTION 4	Appendix 1 – Guidance for Spare Parts	177
1	General	177
3	Spare Parts for Propulsion Steam Turbines	177
5	Spare Parts for Steam Turbines Driving Electric Generators	177

PART

4

CHAPTER 2 Prime Movers

SECTION 1 Diesel Engines

1 General

1.1 **Application** (1 July 2018)

Diesel engines having a rated power of 100 kW (135 hp) and over, intended for propulsion and for auxiliary services essential for propulsion, maneuvering and safety (see 4-1-1/1.3) of the vessel, are to be designed, constructed, tested, certified and installed in accordance with the requirements of this section.

Diesel engines having a rated power of less than 100 kW (135 hp) are not required to comply with the provisions of this section but are to be designed, constructed and equipped in accordance with good commercial and marine practice. Acceptance of such engines will be based on manufacturer's affidavit, verification of engine nameplate data, and subject to a satisfactory performance test after installation conducted in the presence of the Surveyor.

Diesel engines having a rated power of 100 kW (135 hp) and over, intended for services considered not essential for propulsion, maneuvering and safety, are not required to be designed, constructed and certified by ABS in accordance with the requirements of this section. They are to comply with safety features, such as crankcase explosion relief valve, overspeed protection, etc., as provided in 4-2-1/7, as applicable. After installation, they are subject to a satisfactory performance test conducted in the presence of the Surveyor.

Piping systems serving diesel engines, such as fuel oil, lubricating oil, cooling water, starting air, crankcase ventilation and exhaust gas systems are addressed in Section 4-6-5; hydraulic and pneumatic systems are addressed in Section 4-6-7.

Requirements for turbochargers are provided in Section 4-2-2.

Additional requirements for dual fuel and gas internal combustion engines are provided in Sections 5C-8-16 and 5C-13-10 of the Marine Vessel Rules.

Additional requirements for exhaust emission abatement equipment connected to internal combustion engines or boilers are provided in the ABS Guide for Exhaust Emission Abatement.

1.3 **Definitions**

For the purpose of this section, the following definitions apply:

1.3.1 **Slow-, Medium-, High-speed Diesel Engines**

Slow-Speed Engines means crosshead type diesel engines having a rated speed of less than 300 rpm.

Medium-Speed Engines means trunk piston type diesel engines having a rated speed of 300 rpm and above, but less than 1400 rpm.

High-Speed Engines means trunk piston type diesel engines having a rated speed of 1400 rpm or above.

1.3.2 **Rated Power**

The *Rated Power* is the maximum power output at which the engine is designed to run continuously at its rated speed between the normal maintenance intervals recommended by the manufacturer.

1.5 Increased Power Rating

The rated power of an engine, which has been type tested as specified in 4-2-1/13.7 or 4-2-1/13.11 and which has proven reliable in service, may be increased by not more than 10% of the type tested power rating without performing any new type test, subject to prior approval of relevant plans and particulars.

1.7 Ambient Reference Conditions

The following ambient reference conditions are to be applied by the engine manufacturer for the purpose of determining the rated power of diesel engines used on vessels with unrestricted service. However, the engine manufacturer is not expected to provide simulated ambient reference conditions at any test.

Barometric pressure:	1 bar (1 kgf/cm ² , 15 psi)
Air temperature:	45°C (113°F)
Relative air humidity:	60%
Seawater Temperature (Charging air coolant inlet):	32°C (90°F)

1.9 Plans and Particulars to be Submitted

For a tabulated listing, see Appendix 4-2-A1.

1.9.1 Engine Construction

Engine transverse cross-section

Engine longitudinal section

Bedplate with welding details and procedures; frame/column with welding details and procedures; crankcase with welding details and procedures

Structural supporting and seating arrangements

Arrangement of foundation bolts (for main engines only)

Thrust bearing assembly

Thrust bearing bedplate

Tie rod

Cylinder cover, assembly or cylinder head

Cylinder jacket or engine block

Cylinder liner

Crankshaft, details

Crankshaft, assembly

Thrust shaft or intermediate shaft (if integral with engine)

Coupling bolts

Counterweights (if not integral with crankshaft)

Connecting rod

Connecting rod, assembly and details

Crosshead, assembly and details

Piston rod, assembly and details

Piston, assembly and details

Camshaft drive, assembly

Arrangement of crankcase explosion relief valve and breather arrangement (only for engines having a cylinder bore of 200 mm (8 in.) and above)

1.9.2 Engine Systems and Appurtenances

Starting air system
Fuel oil system
Lubricating oil system
Cooling water system
Governor arrangements
Schematic diagram of the engine control and safety system
Shielding and insulation of exhaust pipes, assembly
Shielding of high pressure fuel pipes, assembly as applicable
Turbochargers and superchargers, see 4-2-2/1.5
Couplings and clutches
Vibration damper assembly
Tuning wheel assembly, if fitted
Engine driven pump assembly
Scavenging pump and blower assemblies

1.9.3 Data

Type designation of engine and combustion cycle
Number of cylinders
Rated power, kW (PS, hp)
Rated engine speed, (rpm)
Sense of rotation (clockwise/counter-clockwise)
Firing order with the respective ignition intervals and, where necessary, V-angle, α_v
Cylinder diameter, mm (in.)
Stroke, mm (in.)
Maximum cylinder pressure p_{max} , bar (kgf/mm², psi)
Mean effective pressure, bar (kgf/mm², psi)
Mean indicated pressure, bar (kgf/mm², psi)
Charge air pressure, bar (kgf/mm², psi), (before inlet valves or scavenge ports, whichever applies)
Nominal compression ratio
Connecting rod length L_H , mm (in.)
Oscillating mass of one crank gear, kg (lb.), (in case of V-type engines, where necessary, also for the cylinder unit with master and articulated type connecting rod or forked and inner connecting rod)
Mass of reciprocating parts, kg (lb.)
Digitalized gas pressure curve presented at equidistant intervals, bar (kgf/mm², psi) versus crank angle, (intervals equidistant and integrally divisible by the V-angle, but not more than 5 degrees CA)

For engines with articulated-type connecting rod:

- Distance to link point L_A , mm (in.)
- Link angle α_N (degree)
- Connecting rod length (between bearing centers) L_N , mm (in.)
- Tightening torques for pretensioned bolts and studs for reciprocating parts.
- Mass and diameter of flywheel and flywheel effect on engine

Operation and service manuals, including maintenance requirements for servicing and repair and details of any special tools and gauges that are to be used with their fittings/settings, together with any test requirements on completion of the maintenance (see also 4-6-2/9.6).

1.9.4 Materials (1 July 2018)

Crankshaft material:

- Material designation
- Mechanical properties of material (tensile strength, yield strength, elongation (with length of specimen), reduction of area, impact energy)
- Type of forging (open die forged (free form), continuous grain flow forged, close die forged (drop-forged), etc., with description of the forging process)

Crankshaft heat treatment

Crankshaft surface treatment

- Surface treatment of fillets, journals and pins (induction hardened, flame hardened, nitrided, rolled, shot peened, etc., with full details concerning hardening). **For calculation of surface treated fillets and oil bore outlets see Appendix 4-2-1A9.**
- Hardness at surface
- Hardness as a function of depth, mm (in.)
- Extension of surface hardening

Material specifications of other main parts

1.9.5 Calculations and Analyses

Strength analysis for crankshaft and other reciprocating parts

Strength analysis for engine supports and seating arrangements

Torsional vibration analysis for propulsion shafting systems for all modes of operation including the condition of one cylinder misfiring

Calculation demonstrating the adequacy of the bolting arrangement attaching tuning wheels or vibration dampers to the propulsion system to withstand all anticipated torsional vibration and operating loads

1.9.6 Submittals by Licensee

1.9.6(a) Plans lists. For each diesel engine manufactured under license, the licensee is to submit two listings of plans and data to be used in the construction of the engine:

- One list is to contain drawing numbers and titles (including revision status) of the licensor's plans and data of the engine as approved by ABS (including approval information such as location and date at which they are approved); and
- A second list, which is to contain the drawing numbers and titles (including revision status) of the licensee's plans and data, insofar as they are relevant to the construction of the engine. In the event that construction is based solely on the licensor's plans, this list will not be required.

1.9.6(b) Plans for approval. Any design change made by the licensee is to be documented, and relevant plans and data are to be submitted by the licensee for approval or for information, as appropriate. The licensor's statement of acceptance of the modifications is to be included in the submittal.

1.9.6(c) Plans for surveyor. A complete set of the licensor's or the licensee's plans and data, as approved by ABS, is to be made available to the Surveyor attending the licensee's plant.

3 Materials

3.1 Material Specifications and Tests

Material specifications are to be in accordance with that in Part 2, Chapter 3 or other specifications approved under 4-2-1/3.3.1. Except as noted in 4-2-1/3.3, materials intended for engines required to be constructed under survey are to be tested and inspected in accordance with 4-2-1/Table 1. The material tests, where so indicated in the table, are to be witnessed by the Surveyor. Nondestructive tests in 4-2-1/Table 1 are to be carried out by the manufacturer whose test records may be accepted by ABS.

Copies of material specifications or purchase orders are to be submitted to the Surveyor for information.

3.3 Alternative Materials and Tests

3.3.1 Alternative Specifications

Material manufactured to specifications other than those given in Part 2, Chapter 3 may be accepted, provided that such specifications are approved in connection with the design and that they are verified or tested in the presence of a Surveyor, as applicable, as complying with the specifications.

3.3.2 Steel-bar Stock

Hot-rolled steel bars up to 305 mm (12 in.) in diameter may be used when approved for any of the items indicated in 4-2-1/Table 1, subject to the conditions specified in Section 2-3-8

3.3.3 Material for Engines of 375 kW (500 hp) Rated Power or Less

Material for engines having a rated power of 375 kW (500 hp) or less, including shafting, couplings, and coupling bolts will be accepted on the basis of the material manufacturer's certified test reports and a satisfactory surface inspection and hardness check witnessed by the Surveyor. Coupling bolts manufactured to a recognized bolt standard will not require material testing.

3.3.4 Engines Certified Under Quality Assurance Approval

For diesel engines certified under quality assurance assessment as provided for in 4-2-1/13.13.2(b), material tests required by 4-2-1/3.1 need not be witnessed by the Surveyor; such tests are to be conducted by the engine manufacturer whose certified test reports may be accepted instead.

5 Design

5.1 Bedplate/Crankcase

The bedplate or crankcase is to be of rigid construction, oiltight, and provided with a sufficient number of bolts to secure the same to the vessel's structure. See also 4-2-1/11.1 for seating of diesel engines.

5.3 Crankcase Doors

Crankcase construction and crankcase doors are to be of sufficient strength to withstand anticipated crankcase pressures that may arise during a crankcase explosion taking into account the installation of explosion relief valves required by 4-2-1/7.1. Crankcase doors are to be fastened and secured so that they will not be readily displaced by a crankcase explosion.

5.5 Cylinders and Covers, Liners and Pistons

Cylinders, liners, cylinder covers and pistons, which are subjected to high temperatures or pressures, are to be of materials suitable for the stresses and temperatures to which they are exposed.

5.7 Securing of Nuts

All nuts of main bearings and of connecting-rod bolts and all other moving parts are to be secured by split pins or other effective locking means.

5.9 Crankshafts

5.9.1 General

5.9.1(a) Scope. These Rules for the design of crankshafts are to be applied to diesel engines for propulsion and auxiliary purposes, where the engines are being so designed as to be capable of continuous operation at their rated power when running at rated speed.

Where a crankshaft design involves the use of surface treated fillets, when fatigue testing is conducted, or when direct stress (strain) measurements are taken, the relevant documents with calculations/analysis and reliability data are to be submitted in order to substantiate the design.

5.9.1(b) Field of application. These Rules apply only to solid-forged and semi-built crankshafts of forged or cast steel, with one crank throw between main bearings.

5.9.1(c) Principles of calculation. The design of crankshafts is based on an evaluation of safety against fatigue in the highly stressed areas.

The calculation is also based on the assumption that the areas exposed to highest stresses are:

- Fillet transitions between the crankpin and web as well as between the journal and web,
- Outlets of crankpin oil bores.

When journal diameter is equal or larger than the crankpin diameter, the outlets of main journal oil bores are to be formed in a similar way to the crankpin oil bores, otherwise separate documentation of fatigue safety may be required.

Calculation of crankshaft strength consists of determining the nominal alternating bending (see 4-2-1/5.9.2) and nominal alternating torsional stresses (see 4-2-1/5.9.3) which, multiplied by the appropriate stress concentration factors (see 4-2-1/5.9.4), result in an equivalent alternating stress (uni-axial stress) (see 4-2-1/5.9.6). This equivalent alternating stress is then compared with the fatigue strength of the selected crankshaft material (see 4-2-1/5.9.7). This comparison will show whether or not the crankshaft concerned is dimensioned adequately (see 4-2-1/5.9.8).

5.9.2 Calculation of Alternating Stresses Due to Bending Moments and Radial Forces

5.9.2(a) Assumptions. The calculations are based on a quasi-static model where the steady alternating loads are combined in a statically determined system. The statically determined system is composed of a single crank throw supported in the center of adjacent main journals and subject to gas and inertia forces. The bending length is taken as the length between the two main bearing midpoints (distance L_3 , as per 4-2-1/Figure 1 and 4-2-1/Figure 2).

The bending moments M_{BR} and M_{BT} are calculated in the relevant section based on triangular bending moment diagrams due to the radial component F_R and tangential component F_T of the connecting-rod force, respectively (see 4-2-1/Figure 1).

For crank throws with two connecting-rods acting upon one crankpin the relevant bending moments are obtained by superposition of the two triangular bending moment diagrams according to phase (see 4-2-1/Figure 2).

i) Bending moments and radial forces acting in web. The bending moment M_{BRF} and the radial force Q_{RF} are taken as acting in the center of the solid web (distance L_1) and are derived from the radial component of the connecting-rod force.

The alternating bending and compressive stresses due to bending moments and radial forces are to be related to the cross-section of the crank web. This reference section results from the web thickness W and the web width B (see 4-2-1/Figure 3). Mean stresses are neglected.

FIGURE 1
Crank Throw for In Line Engine

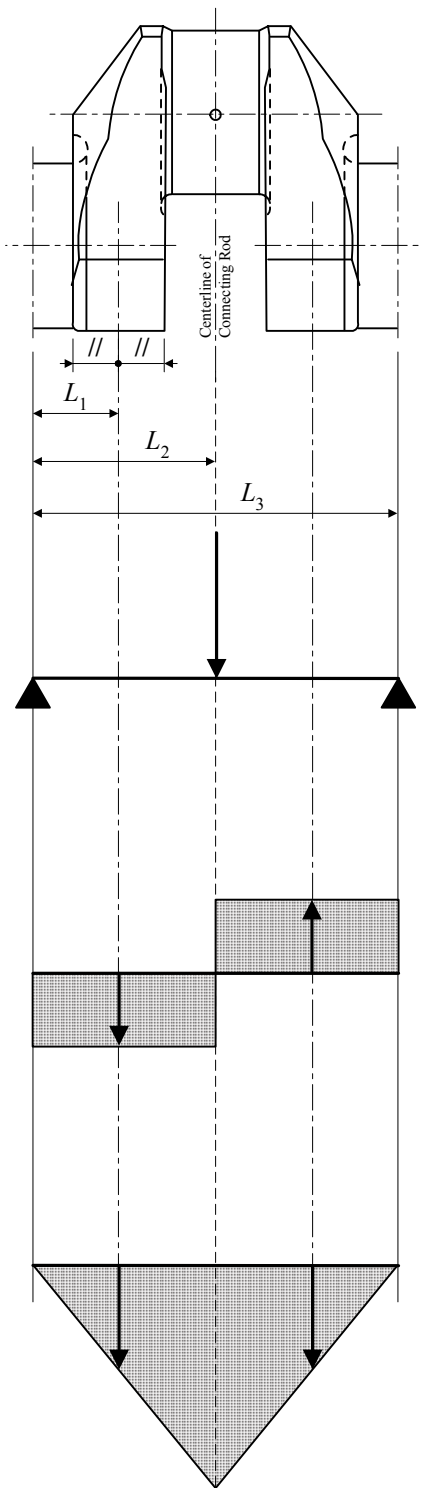
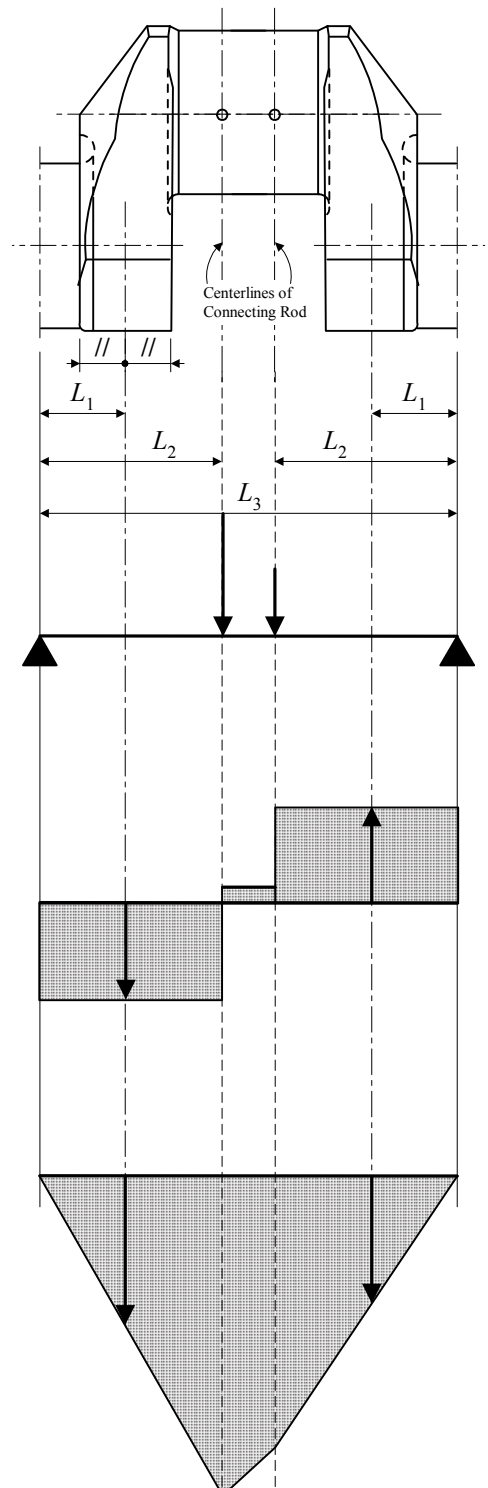
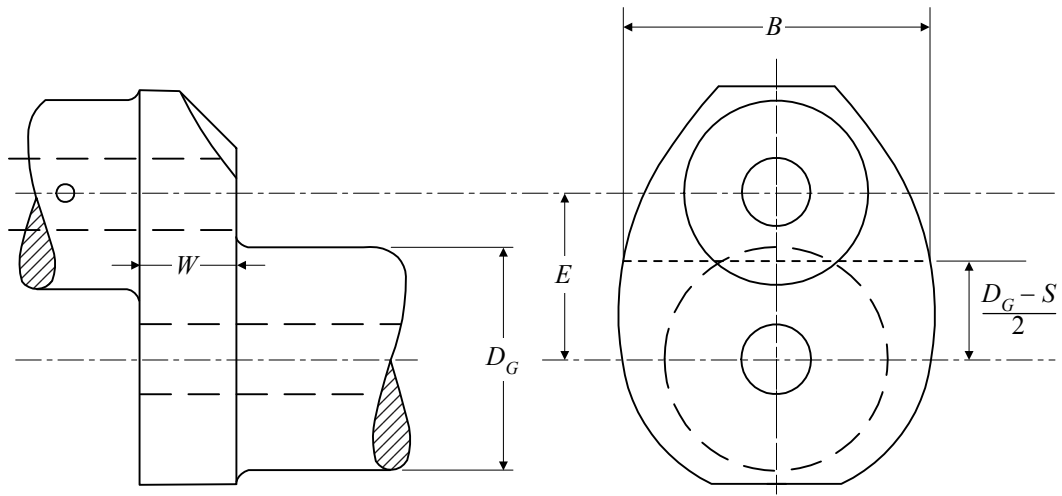

FIGURE 2
Crank Throw for Vee Engine with 2 Adjacent Connecting-Rods



- L_1 = Distance between main journal centerline and crank web center (see also 4-2-1/Figure 3 for crankshaft without overlap)
- L_2 = Distance between main journal centerline and connecting-rod center
- L_3 = Distance between two adjacent main journal centerlines

FIGURE 3
Reference Area of Crank Web Cross Section



Overlapped crankshaft

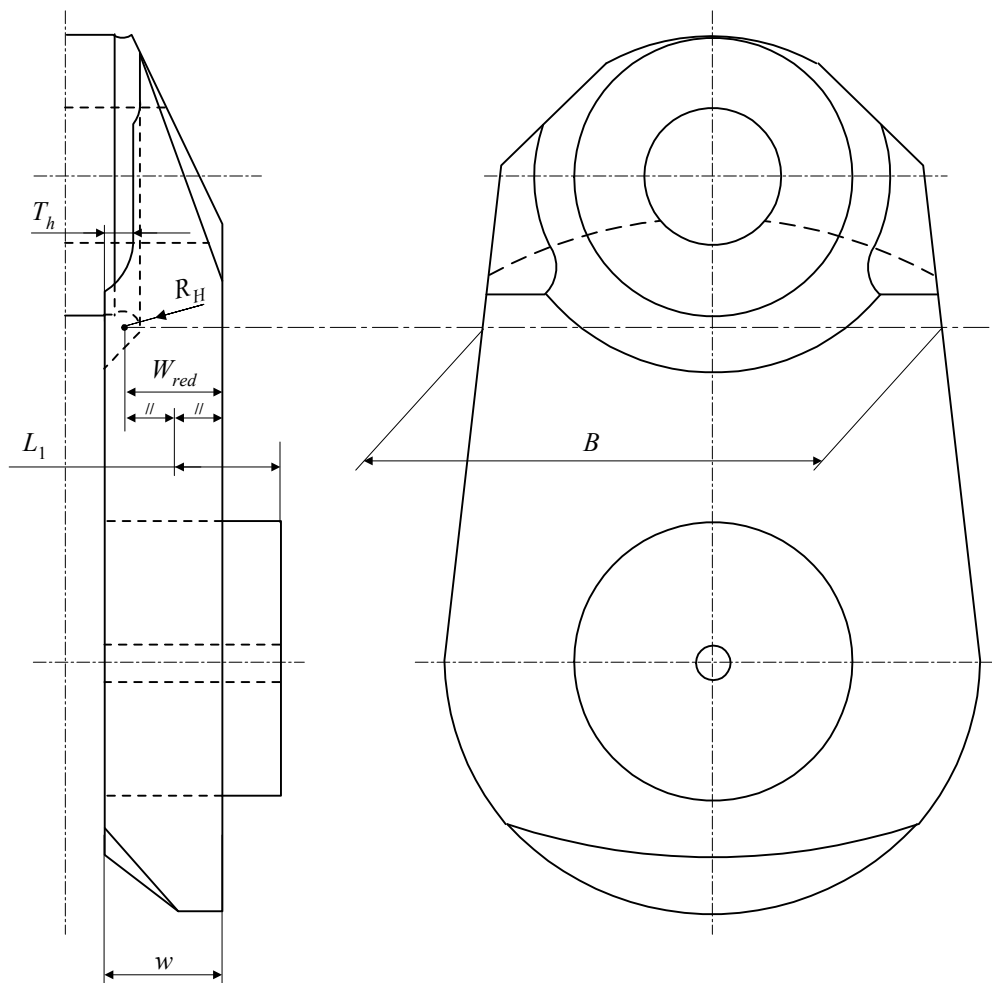

Crankshaft without overlap

- ii) *Bending acting in outlet of crankpin oil bore.* The two relevant bending moments are taken in the crankpin cross-section through the oil bore.

The alternating stresses due to these bending moments are to be related to the cross-sectional area of the axially bored crankpin.

Mean bending stresses are neglected.

FIGURE 4
Crankpin Section Through the Oil Bore

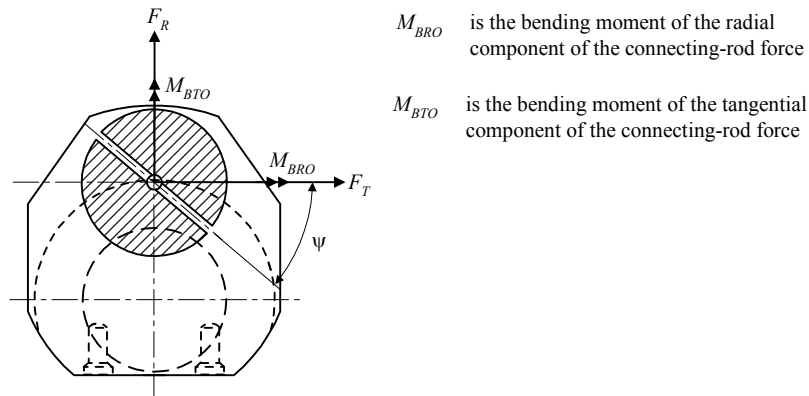

5.9.2(b) *Calculation of nominal alternating bending and compressive stresses in web.* The radial and tangential forces due to gas and inertia loads acting upon the crankpin at each connecting-rod position will be calculated over one working cycle.

Using the forces calculated over one working cycle and taking into account the distance from the main bearing midpoint, the time curve of the bending moments M_{BRF} , M_{BRO} , M_{BTO} and radial forces Q_{RF} , as defined in 4-2-1/5.9.2(a)i) and 4-2-1/5.9.2(a)ii) will then be calculated.

In case of V-type engines, the bending moments – progressively calculated from the gas and inertia forces – of the two cylinders acting on one crank throw are superposed according to phase. Different designs (forked connecting-rod, articulated-type connecting-rod or adjacent connecting-rods) are to be taken into account.

Where there are cranks of different geometrical configurations in one crankshaft, the calculation is to cover all crank variants.

The decisive alternating values will then be calculated according to:

$$X_N = \frac{1}{2} [X_{\max} - X_{\min}]$$

where

- X_N = considered as alternating force, moment or stress
- X_{\max} = maximum value within one working cycle
- X_{\min} = minimum value within one working cycle

- i) *Nominal alternating bending and compressive stresses in web cross section.* The calculation of the nominal alternating bending and compressive stresses is as follows:

$$\sigma_{BFN} = \frac{M_{BRFN}}{W_{eqw}} 10^3 K_e$$

$$\sigma_{QFN} = \frac{Q_{RFN}}{F} K_e$$

where

- σ_{BFN} = nominal alternating bending stress related to the web, in N/mm²
- M_{BRFN} = alternating bending moment related to the center of the web, in N-m
 (see 4-2-1/Figure 1 and 4-2-1/Figure 2)
- $$= \frac{1}{2} [M_{BFN \max} - M_{BFN \min}]$$
- W_{eqw} = section modulus related to cross-section of web, in mm³
- $$= \frac{B \cdot W^2}{6}$$
- K_e = empirical factor considering to some extent the influence of adjacent crank and bearing restraint
- = 0.8 for 2-stroke engines
- = 1.0 for 4-stroke engines
- σ_{QFN} = nominal alternating compressive stress due to radial force related to the web, in N/mm²
- Q_{RFN} = alternating radial force related to the web, in N (see 4-2-1/Figure 1 and 4-2-1/Figure 2)
- $$= \frac{1}{2} [Q_{RF \max} - Q_{RF \min}]$$
- F = area related to cross-section of web, in mm²
- $$= B \cdot W$$

- ii) *Nominal alternating bending stress in outlet of crankpin oil bore.* The calculation of nominal alternating bending stress is as follows:

$$\sigma_{BON} = \frac{M_{BON}}{W_e} 10^3$$

where

- σ_{BON} = nominal alternating bending stress related to the crank pin diameter, in N/mm²
- M_{BON} = alternating bending moment calculated at the outlet of crankpin oil bore, in N-m
- $$= \frac{1}{2} [M_{BO \max} - M_{BO \min}]$$
- M_{BO} = ($M_{BTO} \cdot \cos \psi + M_{BRO} \cdot \sin \psi$)
- ψ = angular position, in degrees (see 4-2-1/Figure 4)

$$W_e = \text{section modulus related to cross-section of axially bored crankpin, in mm}^3$$

$$= \frac{\pi}{32} \left[\frac{D^4 - D_{BH}^4}{D} \right]$$

5.9.2(c) *Calculation of alternating bending stresses in fillets.* The calculation of stresses is to be carried out for the crankpin fillet as well as for the journal fillet.

- For the crankpin fillet :

$$\sigma_{BH} = (\alpha_B \sigma_{BFN})$$

where

$$\sigma_{BH} = \text{alternating bending stress in crankpin fillet, in N/mm}^2$$

$$\alpha_B = \text{stress concentration factor for bending in crankpin fillet (see 4-2-1/5.9.4)}$$

- For the journal fillet (not applicable to semi-built crankshaft):

$$\sigma_{BG} = (\beta_B \sigma_{BFN} + \beta_Q \sigma_{QFN})$$

where

$$\sigma_{BG} = \text{alternating bending stress in journal fillet, in N/mm}^2$$

$$\beta_B = \text{stress concentration factor for bending in journal fillet (see 4-2-1/5.9.4)}$$

$$\beta_Q = \text{stress concentration factor for compression due to radial force in journal fillet (determination as per 4-2-1/5.9.4)}$$

5.9.2(d) *Calculation of alternating bending stresses in outlet of crankpin oil bore.*

$$\sigma_{BO} = (\gamma_B \sigma_{BON})$$

where

$$\sigma_{BO} = \text{alternating bending stress in outlet of crankpin oil bore, in N/mm}^2$$

$$\gamma_B = \text{stress concentration factor for bending in crankpin oil bore (determination as per 4-2-1/5.9.4)}$$

5.9.3 Calculation of Alternating Torsional Stresses

5.9.3(a) *General.* The alternating torsional stresses that are to be used in determining the equivalent alternating stress in the crankshaft are to be provided by the engine manufacturer, and substantiated either by appropriate calculations, or by crankshaft fatigue testing.

Where applicable, the calculation for nominal alternating torsional stresses is to be undertaken by the engine manufacturer according to the information contained in 4-2-1/5.9.3(b). In either case supporting documentation is to be submitted for review.

5.9.3(b) *Calculation of nominal alternating torsional stresses.* The maximum and minimum torques are to be ascertained for every mass point of the complete dynamic system and for the entire speed range by means of a harmonic synthesis of the forced vibrations from the 1st order up to and including the 15th order for 2-stroke cycle engines and from the 0.5th order up to and including the 12th order for 4-stroke cycle engines. Allowance must be made for the damping that exists in the system and for unfavorable conditions (misfiring [*] in one of the cylinders). The speed step calculation is to be selected in such a way that any resonance found in the operational speed range of the engine is to be detected.

* *Note:* Misfiring is defined as cylinder condition when no combustion occurs but only a compression cycle.

Where barred speed ranges are necessary, they are to be arranged so that satisfactory operation is possible despite their existence. There are to be no barred speed ranges above a speed ratio of $\lambda \geq 0.8$ for normal firing conditions.

The values received from such calculation are to be submitted for review.

The nominal alternating torsional stress in every mass point, which is essential to the assessment, results from the following equation:

$$\tau_N = \frac{M_{TN}}{W_P} 10^3$$

$$M_{TN} = \frac{1}{2} [M_{T_{\max}} - M_{T_{\min}}]$$

$$W_P = \frac{\pi}{16} \left(\frac{D^4 - D_{BH}^4}{D} \right) \text{ or } \frac{\pi}{16} \left(\frac{D_G^4 - D_{BG}^4}{D_G} \right)$$

where

- τ_N = nominal alternating torsional stress referred to crankpin or journal, in N/mm²
- M_{TN} = maximum alternating torque, in N-m
- W_P = polar section modulus related to cross-section of axially bored crankpin or bored journal, in mm³
- $M_{T_{\max}}$ = maximum value of the torque, in N-m
- $M_{T_{\min}}$ = minimum value of the torque, in N-m

For the purpose of the crankshaft assessment, the nominal alternating torsional stress considered in further calculations is the highest calculated value, according to the above method, occurring at the most torsionally loaded mass point of the crankshaft system.

Where barred speed ranges exist, the torsional stresses within these ranges are not to be considered for assessment calculations.

Approval of the crankshaft will be based on the installation having the largest nominal alternating torsional stress (but not exceeding the maximum figure specified by the engine manufacturer).

Thus, for each installation, it is to be ensured by suitable calculation that this approved nominal alternating torsional stress is not exceeded. This calculation is to be submitted for review.

5.9.3(c) *Calculation of alternating torsional stresses in fillets and outlet of crankpin oil bore.*
 The calculation of stresses is to be carried out for the crankpin fillet, the journal fillet and the outlet of the crankpin oil bore.

- For the crankpin fillet:

$$\tau_H = (\alpha_T \tau_N)$$

where

- τ_H = alternating torsional stress in crankpin fillet, in N/mm²
- α_T = stress concentration factor for torsion in crankpin fillet (determination as per 4-2-1/5.9.4)
- τ_N = nominal alternating torsional stress related to crankpin diameter, in N/mm²

- For the journal fillet (not applicable to semi-built crankshafts)

$$\tau_G = (\beta_T \tau_N)$$

where

$$\tau_G = \text{alternating torsional stress in journal fillet, in N/mm}^2$$

$$\beta_T = \text{stress concentration factor for torsion in journal fillet (determination as per 4-2-1/5.9.4)}$$

$$\tau_N = \text{nominal alternating torsional stress related to journal diameter, in N/mm}^2$$

- For the outlet of crankpin oil bore

$$\tau_{TO} = (\gamma_T \tau_N)$$

where

$$\tau_{TO} = \text{alternating stress in outlet of crankpin oil bore due to torsion, in N/mm}^2$$

$$\gamma_T = \text{stress concentration factor for torsion in outlet of crankpin oil bore (determination as per 4-2-1/5.9.4)}$$

$$\tau_N = \text{nominal alternating torsional stress related to crankpin diameter, in N/mm}^2$$

5.9.4 Evaluation of Stress Concentration Factors

5.9.4(a) *General (1 July 2018)*. The stress concentration factors are evaluated by means of the equations in 4-2-1/5.9.4(b), 4-2-1/5.9.4(c) and 4-2-1/5.9.4(d) applicable to the fillets and crankpin oil bore of solid forged web-type crankshafts and to the crankpin fillets of semi-built crankshafts only. The stress concentration factor equations concerning the oil bore are only applicable to a radially drilled oil hole. Where the geometry of the crankshaft is outside the boundaries of the analytical stress concentration factors (SCF) the calculation method detailed in Appendix 4-2-1A7 may be undertaken. All crank dimensions necessary for the calculation of stress concentration factors are shown in 4-2-1/Figure 5.

The stress concentration factors for bending (α_B , β_B) are defined as the ratio of the maximum equivalent stress (Von Mises) – occurring in the fillets under bending load – to the nominal bending stress related to the web cross-section (see Appendix 4-2-1A2).

The stress concentration factor for compression (β_O) in the journal fillet is defined as the ratio of the maximum equivalent stress (Von Mises), occurring in the fillet due to the radial force, to the nominal compressive stress related to the web cross-section.

The stress concentration factors for torsion (α_T , β_T) are defined as the ratio of the maximum equivalent shear stress, occurring in the fillets under torsional load, to the nominal torsional stress related to the axially bored crankpin or journal cross-section (see Appendix 4-2-1A3).

The stress concentration factors for bending (γ_B) and torsion (γ_T) are defined as the ratio of the maximum principal stress, occurring at the outlet of the crankpin oil-hole under bending and torsional loads, to the corresponding nominal stress related to the axially bored crankpin cross section (see Appendix 4-2-1A3).

When reliable measurements and/or calculations are available, which can allow direct assessment of stress concentration factors, the relevant documents and their analysis method is to be submitted in order to demonstrate their equivalence with the Rules. **This is always to be performed when dimensions are outside of any of the validity ranges for the empirical formulae presented in 4-2-1/5.9.4(b), 4-2-1/5.9.4(c) and 4-2-1/5.9.4(d).**

Appendices 4-2-1A7 and 4-2-1A10 describe how FE analyses can be used for the calculation of the stress concentration factors. Care should be taken to avoid mixing equivalent (Von Mises) stresses and principal stresses.

FIGURE 5
Crank Dimensions

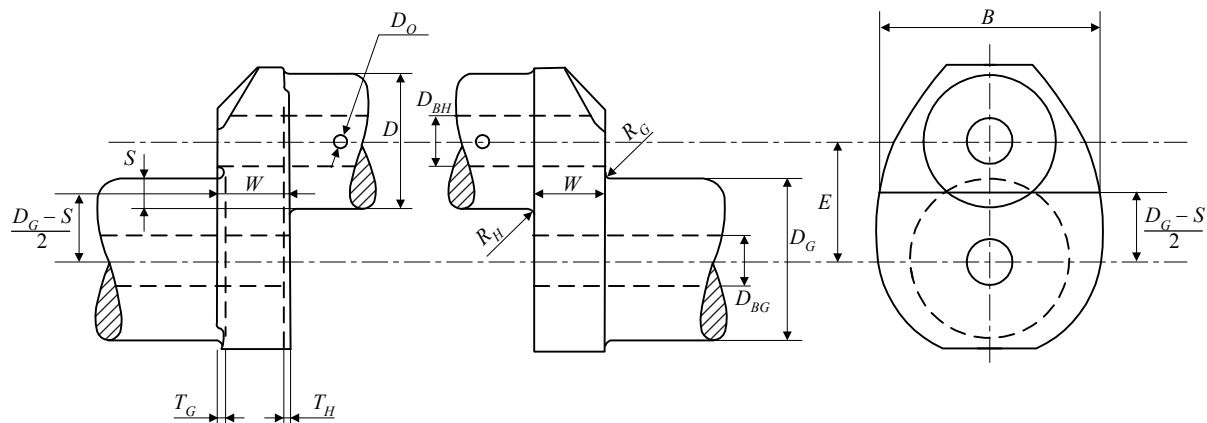

• Actual dimensions:

- D = crankpin diameter, in mm
- D_{BH} = diameter of axial bore in crankpin, in mm
- D_O = diameter of oil bore in crankpin, in mm
- R_H = fillet radius of crankpin, in mm
- T_H = recess of crankpin fillet, in mm
- D_G = journal diameter, in mm
- D_{BG} = diameter of axial bore in journal, in mm
- R_G = fillet radius of journal, in mm
- T_G = recess of journal fillet, in mm
- E = pin eccentricity, in mm
- S = pin overlap, in mm
- = $\frac{D + D_G}{2} - E$
- W^* = web thickness, in mm
- B^* = web width, in mm

* Note: In the case of 2 stroke semi-built crankshafts:

- When $T_H > R_H$, the web thickness must be considered as equal to:

$$W_{red} = W - (T_H - R_H) \quad (\text{see 4-2-1/Figure 3})$$

- Web width B must be taken in way of crankpin fillet radius center according to 4-2-1/Figure 3

The following related dimensions will be applied for the calculation of stress concentration factors:

<i>Crankpin fillet</i>	<i>Journal fillet</i>
$r = R_H/D$	$r = R_G/D$
$s = S/D$	
$w = W/D$	crankshafts with overlap
	W_{red}/D crankshafts without overlap
$b = B/D$	
$d_o = D_O/D$	
$d_G = D_{BG}/D$	
$d_H = D_{BH}/D$	
$t_H = T_H/D$	
$t_G = T_G/D$	

Stress concentration factors are valid for the ranges of related dimensions for which the investigations have been carried out. Ranges are as follows:

$$s \leq 0.5$$

$$0.2 \leq w \leq 0.8$$

$$1.1 \leq b \leq 2.2$$

$$0.03 \leq r \leq 0.13$$

$$0 \leq d_G \leq 0.8$$

$$0 \leq d_H \leq 0.8$$

$$0 \leq d_o \leq 0.2$$

Low range of s can be extended down to large negative values provided that:

- If calculated $f(recess) < 1$ then the factor $f(recess)$ is not to be considered ($f(recess) = 1$)
- If $s < -0.5$ then $f(s,w)$, $f(r,s)$ and $f_B(s,w)$ are to be evaluated replacing actual value of s by -0.5 .

5.9.4(b) Crankpin fillet.

- The stress concentration factor for bending (α_B) is:

$$\alpha_B = 2.6914 \cdot f(s,w) \cdot f(w) \cdot f(b) \cdot f(r) \cdot f(d_G) \cdot f(d_H) \cdot f(recess)$$

where

$$f(s,w) = -4.1883 + 29.2004 \cdot w - 77.5925 \cdot w^2 + 91.9454 \cdot w^3 - 40.0416 \cdot w^4 + (1-s) \cdot (9.5440 - 58.3480 \cdot w + 159.3415 \cdot w^2 - 192.5846 \cdot w^3 + 85.2916 \cdot w^4) + (1-s)^2 \cdot (-3.8399 + 25.0444 \cdot w - 70.5571 \cdot w^2 + 87.0328 \cdot w^3 - 39.1832 \cdot w^4)$$

$$f(w) = 2.1790 \cdot w^{0.7171}$$

$$f(b) = 0.6840 - 0.0077 \cdot b + 0.1473 \cdot b^2$$

$$f(r) = 0.2081 \cdot r^{(-0.5231)}$$

$$f(d_G) = 0.9993 + 0.27 \cdot d_G - 1.0211 \cdot d_G^2 + 0.5306 \cdot d_G^3$$

$$f(d_H) = 0.9978 + 0.3145 \cdot d_H - 1.5241 \cdot d_H^2 + 2.4147 \cdot d_H^3$$

$$f(recess) = 1 + (t_H + t_G) \cdot (1.8 + 3.2 \cdot s)$$

- The stress concentration factor for torsion (α_T) is :

$$\alpha_T = 0.8 \cdot f(r,s) \cdot f(b) \cdot f(w)$$

where

$$f(r,s) = r^{[-0.322 + 0.1015 \cdot (1-s)]}$$

$$f(b) = 7.8955 - 10.654 \cdot b + 5.3482 \cdot b^2 - 0.857 \cdot b^3$$

$$f(w) = w^{(-0.145)}$$

5.9.4(c) *Journal fillet (not applicable to semi-built crankshaft).*

- The stress concentration factor for bending (β_B) is:

$$\beta_B = 2.7146 \cdot f_B(s,w) \cdot f_B(w) \cdot f_B(b) \cdot f_B(r) \cdot f_B(d_G) \cdot f_B(d_H) \cdot f(recess)$$

where

$$f_B(s,w) = -1.7625 + 2.9821 \cdot w - 1.5276 \cdot w^2 + (1-s) \cdot (5.1169 - 5.8089 \cdot w + 3.1391 \cdot w^2) + (1-s)^2 \cdot (-2.1567 + 2.3297 \cdot w - 1.2952 \cdot w^2)$$

$$f_B(w) = 2.2422 \cdot w^{0.7548}$$

$$f_B(b) = 0.5616 + 0.1197 \cdot b + 0.1176 \cdot b^2$$

$$f_B(r) = 0.1908 \cdot r^{(-0.5568)}$$

$$f_B(d_G) = 1.0012 - 0.6441 \cdot d_G + 1.2265 \cdot d_G^2$$

$$f_B(d_H) = 1.0022 - 0.1903 \cdot d_H + 0.0073 \cdot d_H^2$$

$$f(recess) = 1 + (t_H + t_G) \cdot (1.8 + 3.2 \cdot s)$$

- The stress concentration factor for compression (β_Q) due to the radial force is:

$$\beta_Q = 3.0128 \cdot f_Q(s) \cdot f_Q(w) \cdot f_Q(b) \cdot f_Q(r) \cdot f_Q(d_H) \cdot f(recess)$$

where

$$f_Q(s) = 0.4368 + 2.1630 \cdot (1-s) - 1.5212 \cdot (1-s)^2$$

$$f_Q(w) = \frac{w}{0.0637 + 0.9369 \cdot w}$$

$$f_Q(b) = -0.5 + b$$

$$f_Q(r) = 0.5331 \cdot r^{(-0.2038)}$$

$$f_Q(d_H) = 0.9937 - 1.1949 \cdot d_H + 1.7373 \cdot d_H^2$$

$$f(recess) = 1 + (t_H + t_G) \cdot (1.8 + 3.2 \cdot s)$$

- The stress concentration factor for torsion (β_T) is:

$$\beta_T = \alpha_T \quad \text{if the diameters and fillet radii of crankpin and journal are the same}$$

$$\beta_T = 0.8 \cdot f(r,s) \cdot f(b) \cdot f(w) \quad \text{if crankpin and journal diameters and/or radii are of different sizes}$$

where $f(r,s)$, $f(b)$ and $f(w)$ are to be determined in accordance with 4-2-1/5.9.4(b) (see calculation of α_T), however, the radius of the journal fillet is to be related to the journal diameter:

$$r = \frac{R_G}{D_G}$$

5.9.4(d) Outlet of crankpin oil bore.

- The stress concentration factor for bending (γ_B) is:

$$\gamma_B = 3 - 5.88 \cdot d_o + 34.6 \cdot d_o^2$$

- The stress concentration factor for torsion (γ_T) is:

$$\gamma_T = 4 - 6 \cdot d_o + 30 \cdot d_o^2$$

5.9.5 Additional Bending Stresses

In addition to the alternating bending stresses in fillets (see 4-2-1/5.9.2(c)) further bending stresses due to misalignment and bedplate deformation as well as due to axial and bending vibrations are to be considered by applying σ_{add} as given by the table below:

Type of Engine	σ_{add} [N/mm ²]
Crosshead engines	30 (*)
Trunk piston engines	10

Notes:

- * The additional alternating stress of 30 N/mm² is composed of two components
 - 1 An additional alternating stress of 20 N/mm² resulting from axial vibration
 - 2 An additional alternating stress of 10 N/mm² resulting from misalignment/bedplate deformation

It is recommended that a value of 20 N/mm² be used for the axial vibration component for assessment purposes where axial vibration calculation results of the complete dynamic system (engine/shafting/gearing/propeller) are not available. Where axial vibration calculation results of the complete dynamic system are available, the calculated figures may be used instead.

5.9.6 Calculation of Equivalent Alternating Stress

5.9.6(a) General. In the fillets, bending and torsion lead to two different biaxial stress fields which can be represented by a Von Mises equivalent stress with the additional assumptions that bending and torsion stresses are not time phased and the corresponding peak values occur at the same location (see 4-2-1/Appendix 2).

As a result, the equivalent alternating stress is to be calculated for the crankpin fillet as well as for the journal fillet by using the Von Mises criterion.

At the oil hole outlet, bending and torsion lead to two different stress fields which can be represented by an equivalent principal stress equal to the maximum of the principal stress resulting from combination of these two stress fields with the assumption that bending and torsion are time phased (see 4-2-1/Appendix 3).

The above two different ways of equivalent stress evaluation both lead to stresses which may be compared to the same fatigue strength value of crankshaft assessed according to Von Mises criterion.

5.9.6(b) Equivalent alternating stress. The equivalent alternating stress is calculated in accordance with the following equations.

- For the crankpin fillet:

$$\sigma_v = \pm \sqrt{(\sigma_{BH} + \sigma_{add})^2 + 3 \cdot \tau_H^2}$$

- For the journal fillet:

$$\sigma_v = \pm \sqrt{(\sigma_{BG} + \sigma_{add})^2 + 3 \cdot \tau_G^2}$$

- For the outlet of crankpin oil bore:

$$\sigma_v = \pm \frac{1}{3} \sigma_{BO} \cdot \left[1 + 2 \sqrt{1 + \frac{9}{4} \left(\frac{\tau_{TO}}{\sigma_{BO}} \right)^2} \right]$$

where

σ_v = equivalent alternating stress, in N/mm², for other parameters referred to in 4-2-1/5.9.2(c), 4-2-1/5.9.3(c) and 4-2-1/5.9.5

5.9.7 Calculation of Fatigue Strength (1 July 2018)

The fatigue strength is to be understood as that value of equivalent alternating stress (Von Mises) which a crankshaft can permanently withstand at the most highly stressed points. The fatigue strength may be evaluated by means of the following equations.

- Related to the crankpin diameter:

$$\sigma_{DW} = \pm K \cdot (0.42 \cdot \sigma_B + 39.3) \cdot \left[0.264 + 1.073 \cdot D^{-0.2} + \frac{785 - \sigma_B}{4900} + \frac{196}{\sigma_B} \cdot \sqrt{\frac{1}{R_X}} \right]$$

where

R_X = R_H in the fillet area
 = $D_o/2$ in the oil bore area

- Related to the journal diameter:

$$\sigma_{DW} = \pm K \cdot (0.42 \cdot \sigma_B + 39.3) \cdot \left[0.264 + 1.073 \cdot D_G^{-0.2} + \frac{785 - \sigma_B}{4900} + \frac{196}{\sigma_B} \cdot \sqrt{\frac{1}{R_G}} \right]$$

where

σ_{DW} = allowable fatigue strength of crankshaft, in N/mm²
 K = factor for different types of crankshafts without surface treatment. Values greater than 1 are only applicable to fatigue strength in fillet area.
 = 1.05 for continuous grain flow forged or drop-forged crankshafts
 = 1.0 for free form forged crankshafts (without continuous grain flow) factor for cast steel crankshafts with cold rolling treatment in fillet area
 = 0.93 for cast steel crankshafts manufactured by companies using a cold rolling process approved by ABS
 σ_B = minimum tensile strength of crankshaft material, in N/mm²

For other parameters refer to 4-2-1/5.9.4(c).

When a surface treatment process is applied, it must be specially approved. **Guidance for calculation of surface treated fillets and oil bore outlets is presented in Appendix 4-2-1A9.**

These equations are subject to the following conditions:

- Surfaces of the fillet, the outlet of the oil bore and inside the oil bore (down to a minimum depth equal to 1.5 times the oil bore diameter) shall be smoothly finished.
- For calculation purposes R_H , R_G or R_X are to be taken as not less than 2 mm.

As an alternative, the fatigue strength of the crankshaft can be determined by experiment based either on full size crank throw (or crankshaft) or on specimens taken from a full size crank throw. For evaluation of test results, see Appendix 4-2-1A8.

5.9.8 Acceptability Criteria

The sufficient dimensioning of a crankshaft is confirmed by a comparison of the equivalent alternating stress and the fatigue strength. This comparison has to be carried out for the crankpin fillet, the journal fillet, the outlet of crankpin oil bore and is based on the equation:

$$Q = \frac{\sigma_{DW}}{\sigma_v}$$

where

Q = acceptability factor

Adequate dimensioning of the crankshaft is ensured if the smallest of all acceptability factors satisfies the criteria:

$$Q \geq 1.15$$

5.9.9 Calculation of Shrink-fits of Semi-built Crankshaft

5.9.9(a) General. All crank dimensions necessary for the calculation of the shrink-fit are shown in 4-2-1/Figure 6.

FIGURE 6
Crank Throw of Semi-built Crankshaft

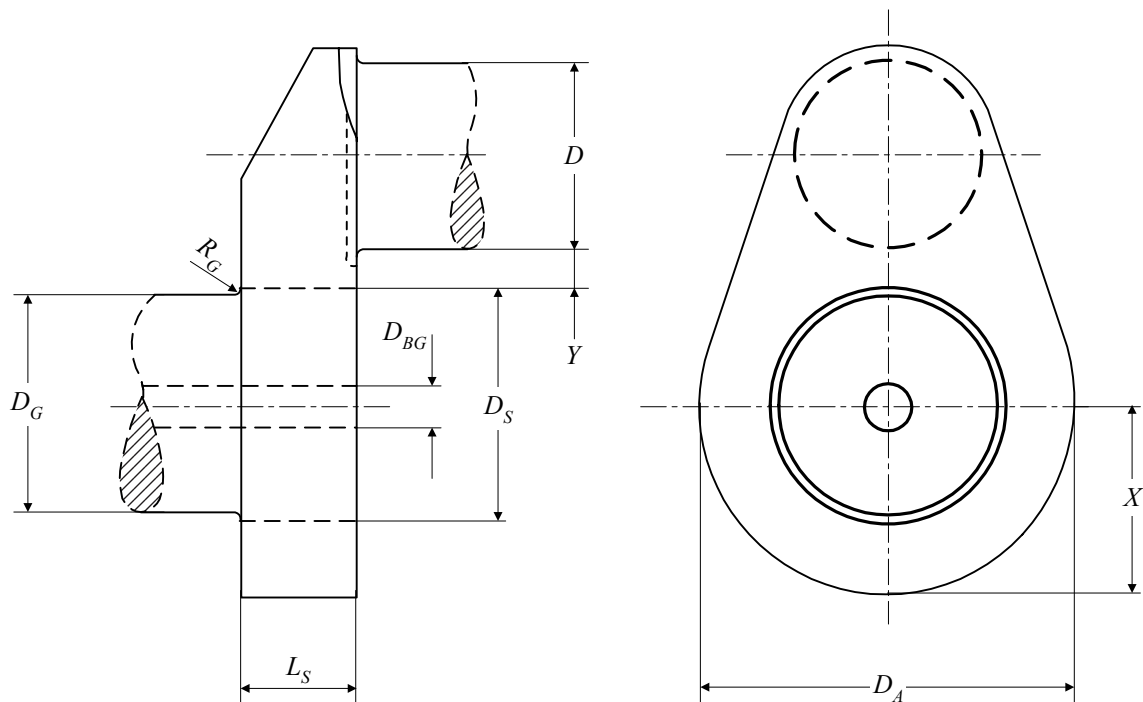

where

D_A = outside diameter of web, in mm, or twice the minimum distance x between center-line of journals and outer contour of web, whichever is less

D_S = shrink diameter, in mm

D_G = journal diameter, in mm

D_{BG} = diameter of axial bore in journal, in mm

L_S = length of shrink-fit, in mm

R_G = fillet radius of journal, in mm

Y = distance between the adjacent generating lines of journal and pin, in mm,
 $Y \geq 0.05 \cdot D_S$

where Y is less than $0.1 \cdot D_S$, special consideration is to be given to the effect of the stress due to the shrink-fit on the fatigue strength at the crankpin fillet.

With regard to the radius of the transition from the journal to the shrink diameter, the following is to be complied with:

$$R_G \geq 0.015 \cdot D_G$$

and

$$R_G \geq 0.5 \cdot (D_S - D_G)$$

where the greater value is to be considered.

The actual oversize Z of the shrink-fit must be within the limits Z_{\min} and Z_{\max} calculated in accordance with 4-2-1/5.9.9(c) and 4-2-1/5.9.9(d)

If the condition in 4-2-1/5.9.9(b) cannot be fulfilled, the calculation methods of Z_{\min} and Z_{\max} in 4-2-1/5.9.9(c) and 4-2-1/5.9.9(d) are not applicable due to multi-zone-plasticity problems.

In such case, Z_{\min} and Z_{\max} have to be established based on FEM calculations.

5.9.9(b) *Maximum permissible hole in the journal pin.* The maximum permissible hole diameter in the journal pin is calculated in accordance with the following equation:

$$D_{BG} = D_S \cdot \sqrt{1 - \frac{4000 \cdot S_R \cdot M_{\max}}{\mu \cdot \pi \cdot D_S^2 \cdot L_S \cdot \sigma_{SP}}}$$

where

S_R = safety factor against slipping, however a value not less than 2 is to be taken unless documented by experiments.

M_{\max} = absolute value of the maximum torque $M_{T_{\max}}$, N-m, in accordance with 4-2-1/5.9.3(b)

μ = coefficient for static friction, however a value not greater than 0.2 is to be taken unless documented by experiments.

σ_{SP} = minimum yield strength of material for journal pin, in N/mm²

This condition serves to avoid plasticity in the hole of the journal pin.

5.9.9(c) *Necessary minimum oversize of shrink-fit.* The necessary minimum oversize is determined by the greater value calculated according to:

$$Z_{\min} \geq \frac{\sigma_{sw} \cdot D_S}{E_m}$$

and

$$Z_{\min} \geq \frac{4000}{\mu \cdot \pi} \cdot \frac{S_R \cdot M_{\max}}{E_m \cdot D_S \cdot L_S} \cdot \frac{1 - Q_A^2 \cdot Q_S^2}{(1 - Q_A^2) \cdot (1 - Q_S^2)}$$

where

Z_{\min} = minimum oversize, in mm

E_m = Young's modulus, in N/mm²

σ_{sw} = minimum yield strength of material for crank web, in N/mm²

Q_A = web ratio, $Q_A = \frac{D_S}{D_A}$

Q_S = shaft ratio, $Q_S = \frac{D_{BG}}{D_S}$

5.9.9(d) *Maximum permissible oversize of shrink-fit.* The maximum permissible oversize is calculated according to:

$$Z_{\max} \leq D_S \cdot \left(\frac{\sigma_{sw}}{E_m} + \frac{0.8}{1000} \right)$$

This condition serves to restrict the shrinkage induced mean stress in the fillet.

5.9.10 Other Reciprocating Components

All other reciprocating components (e.g., connecting rod) are to have acceptability factors of at least 1.15. Tightening torques are to be submitted for pretensioned bolts/studs.

5.11 Shaft Couplings and Clutches

The design and construction of fitted bolt and non-fitted bolt couplings, flexible couplings and clutches is to be in accordance with the provisions of 4-3-2/5.19.

7 Engine Appurtenances

7.1 Explosion Relief Valves

7.1.1 Application

Explosion relief valves of an approved type are to be installed on enclosed crankcases of all engines having a cylinder bore of 200 mm (8 in.) or above or having a crankcase gross volume of 0.6 m³ (21 ft³) or above.

7.1.2 Valve Construction and Sizing

The following requirements apply:

- i) The free area of each explosion relief valve is not to be less than 45 cm² (7 in²), and the total free area of all relief valves is to be not less than 115 cm² for each cubic meter (1 in² for each 2 ft³) of crankcase gross volume. The total volume of the stationary parts within the crankcase may be discounted in estimating the crankcase gross volume (rotating and reciprocating components are to be included in the gross volume).

- ii) Crankcase explosion relief valves are to be provided with lightweight spring-loaded valve discs or other quick-acting and self-closing devices to relieve a crankcase of pressure in the event of an internal explosion and to prevent the inrush of air thereafter.
- iii) The valve discs in crankcase explosion relief valves are to be made of ductile material capable of withstanding the shock of contact with stoppers at the full open position.
- iv) Crankcase explosion relief valves are to be designed and constructed to open quickly and be fully open at a pressure not greater than 0.2 bar (0.2 kgf/cm², 2.85 psi).
- v) Crankcase explosion relief valves are to be provided with a flame arrester that permits flow for crankcase pressure relief and prevents passage of flame following a crankcase explosion.
- vi) Crankcase explosion relief valves are to be type tested in a configuration that represents the installation arrangements that will be used on an engine in accordance with Appendix 4-2-1A5.
- vii) Where crankcase relief valves are provided with arrangements for shielding emissions from the valve following an explosion, the valve is to be type tested to demonstrate that the shielding does not adversely affect the operational effectiveness of the valve.
- viii) Crankcase explosion relief valves are to be provided with a copy of the manufacturer's installation and maintenance manual that is pertinent to the size and type of valve being supplied for installation on a particular engine. The manual is to contain the following information:
 - Description of valve with details of function and design limits.
 - Copy of type test certification.
 - Installation instructions.
 - Maintenance in service instructions to include testing and renewal of any sealing arrangements.
 - Actions required after a crankcase explosion.
- ix) A copy of the installation and maintenance manual is to be provided on board.
- x) Plans showing details and arrangements of the crankcase explosion relief valves are to be submitted for approval in accordance with 4-2-1/1.9.
- xi) Valves are to be provided with suitable markings that include the following information:
 - Name and address of manufacturer
 - Designation and size
 - Month/Year of manufacture
 - Approved installation orientation

7.1.3 Location of Valves

Engines having a bore of 200 mm (8 in.) and above, but not exceeding 250 mm (10 in.), are to have at least one valve near each end. However, for engines with more than 8 crank throws, an additional valve is to be fitted near the middle of the engine.

Engines having a bore exceeding 250 mm (10 in.), but not exceeding 300 mm (11.8 in.), are to have at least one valve in way of each alternate crank throw, with a minimum of two valves.

Engines having a bore exceeding 300 mm (11.8 in.) are to have at least one valve in way of each main crank throw.

7.1.4 Other Compartments of Crankcase

Additional relief valves are to be fitted on separate spaces of the crankcase such as gear or chain cases for camshaft or similar drives when the gross volume of such spaces is 0.6 m³ (21 ft³) and above.

7.1.5 Scavenge Spaces

Explosion relief valves are to be fitted in scavenge spaces which are in open connection to the cylinders.

7.2 Protection Against Crankcase Explosions

7.2.1 General

All engines rated at 2250 kW (3016 hp) and above or having cylinders of more than 300 mm (11.8 in.) bore are to be provided with one of the following arrangements as protection against crankcase explosions.

- Oil mist detection arrangements (see 4-2-1/7.2.2), or
- Bearing temperature monitoring arrangements (see 4-2-1/7.2.3), or
- Alternative arrangements (see 4-2-1/7.2.4).

For low speed diesel engines, the above protection arrangements are to initiate an alarm and an automatic slowdown of the engine.

For medium and high speed diesel engines, they are to initiate an alarm and an automatic shutdown of the engine.

For automatic shutdown or automatic slowdown for vessels with the **ACCU/ABCU** notation, see item B7 of 4-9-6/Table 1A, item B4 of 4-9-6/Table 1B, item G4 of 4-9-6/Table 4B and item A3 of 4-9-6/Table 6.

Automatic shutdown is not permitted for emergency diesel engines, see 4-8-2/5.19.2(c) and item B3 of 4-8-2/Table 1.

7.2.2 Oil Mist Detection Arrangements

7.2.2(a) General. Where crankcase oil mist detection arrangements are fitted to engines, they are to be of an approved type and tested in accordance with Appendix 4-2-1A6.

7.2.2(b) Installation. The oil mist detection system and arrangements are to be installed in accordance with the engine designer's and oil mist manufacturer's instructions/recommendations. The following particulars are to be included in the instructions:

- i)* Schematic layout of engine oil mist detection and alarm system showing location of engine crankcase sample points and piping or cable arrangements together with pipe dimensions to detector.
- ii)* Evidence of study to justify the selected location of sample points and sample extraction rate (if applicable) in consideration of the crankcase arrangements and geometry and the predicted crankcase atmosphere where oil mist can accumulate. All areas that have open communication with the crankcase are to be adequately monitored.
- iii)* The manufacturer's maintenance and test manual.
- iv)* Information relating to type or in-service testing of the engine with engine protection system test arrangements having approved types of oil mist detection equipment.

A copy of the oil mist detection equipment maintenance and test manual required is to be provided onboard.

7.2.2(c) Arrangements. The following requirements apply:

- i)* Oil mist detection and alarm information is to be capable of being read from a safe location away from the engine.
- ii)* Each engine is to be provided with its own independent oil mist detection arrangement and a dedicated alarm.
- iii)* Oil mist detection and alarm systems are to be capable of being tested on the test bed and onboard under engine at standstill and engine running at normal operating conditions in accordance with manufacturer's test procedures.

- iv) Alarms, automatic slowdowns and automatic shutdowns for the oil mist detection system are to be in accordance with 4-2-1/7.2.1, 4-8-2/Table 1, 4-9-6/Table 1A, 4-9-6/Table 1B, 4-9-6/Table 4B and 4-9-6/Table 6, as applicable. The system arrangements are to comply with 4-9-2/3.1.
- v) The oil mist detection arrangements are to provide an alarm indication in the event of a foreseeable functional failure in the equipment and installation arrangements.
- vi) The oil mist detection system is to provide an indication that any lenses fitted in the equipment and used in determination of the oil mist level have been partially obscured to a degree that will affect the reliability of the information and alarm indication.
- vii) Where oil mist detection equipment includes the use of programmable electronic systems, the arrangements are to be in accordance with 4-9-3/5.
- viii) Plans showing details and arrangements of oil mist detection and alarm arrangements are to be submitted for approval in accordance with 4-2-1A1/28.
- ix) The equipment, together with detectors, is to be tested in the presence of the Surveyor when installed on the test bed and onboard to demonstrate that the detection and alarm system functionally operates.
- x) Where sequential oil mist detection arrangements are provided the sampling frequency and time is to be as short as reasonably practicable.

7.2.3 Bearing Temperature Monitoring Arrangements

Where bearing temperature monitoring arrangements are provided, the following requirements apply:

7.2.3(a) Monitoring of bearings. All bearings (main, crank, crosshead, thrust, etc.) that have open communication with the crankcase are to be monitored for abnormal temperature.

7.2.3(b) Slow Speed Diesel Engines. For slow speed diesel engines, the lubricating oil temperature at the outlet of each main, crank, crosshead and thrust bearing may be monitored in lieu of directly monitoring the temperature of these bearings.

7.2.3(c) Alarms, automatic slowdowns and automatic shutdowns for bearing temperature monitoring arrangements are to be in accordance with 4-2-1/7.2.1, 4-8-2/Table 1, 4-9-6/Table 1A, 4-9-6/Table 1B, 4-9-6/Table 4B and 4-9-6/Table 6, as applicable. The system arrangements are to comply with 4-9-2/3.1.

7.2.4 Alternative Arrangements

Where alternative arrangements are provided for the prevention of the build-up of oil mist that may lead to a potentially explosive condition within the crankcase details are to be submitted for review, in order to determine the effectiveness of the arrangements for each specific engine design. In order to prevent the buildup of a potentially explosive condition, it may be necessary to provide combinations of means, such as: oil splash temperature monitoring, crankcase pressure monitoring, recirculation arrangements. The details are to include, but not be limited to the following:

- Engine particulars – type, power, speed, stroke, bore and crankcase volume.
- Details of arrangements to prevent the buildup of potentially explosive conditions within the crankcase.
- Evidence to demonstrate that the arrangements are effective in preventing the buildup of potentially explosive conditions together with details of in-service experience.
- Operating instructions and the maintenance and test instructions.

Where it is proposed to use the introduction of inert gas into the crankcase to minimize a potential crankcase explosion, details of the arrangements are to be submitted for consideration.

7.3 Governors and Overspeed Protection

7.3.1 Governors

All diesel engines, except those driving electric generators (see 4-2-1/7.5), are to be fitted with governors which will prevent the engines from exceeding the rated speed by more than 15%.

7.3.2 Overspeed Protective Device

In addition to the governor, each main propulsion engine having a rated power of 220 kW (295 hp) and over and which can be declutched or which drives a controllable pitch propeller, is to be fitted with a overspeed device so adjusted that the speed cannot exceed the maximum rated speed by more than 20%. This overspeed device, including its driving mechanism, is to be independent from the normal governor.

7.3.3 Electronic Governors

Electronic speed governors fitted to main propulsion diesel engines, and which form part of a remote propulsion control system, are to comply with the following:

- i)* If lack of power to the governor control and actuator systems may cause major and sudden changes in the preset speed and/or direction of thrust of the propeller, an automatically available back up power supply is to be provided so as not to interrupt the power supply to these systems. An alarm for the failure of the main power supply is to be provided at the main and remote (if provided) propulsion control stations.
- ii)* Local control of the engines is to be possible. For this purpose, means are to be provided at the local control position to disconnect the remote control signal. If this will also disconnect the speed governing functions required by 4-2-1/7.3.1, an additional separate speed governor is to be provided for such local mode of control.
- iii)* Electronic speed governors and their electrical actuators are to be subjected to prototype environmental tests in accordance with 4-9-9/13.1. In addition, the tests required by 4-9-9/Table 2 are to be carried out in the presence of the Surveyor as prototype testing. However, no production unit certification in accordance with 4-9-9/13.3 is required.

7.5 Governors and Overspeed Protection for Engines Driving Generators

7.5.1 Speed Governing

Diesel engines driving propulsion, auxiliary or emergency electric generators are to be fitted with an operating governor which is capable of automatically maintaining the speed within the following limits:

7.5.1(a) The transient frequency variations in the electrical network when running at the indicated loads below are to be within $\pm 10\%$ of the rated frequency with a recovery time within $\pm 1\%$ of the final steady state condition in not more than 5 seconds when:

- i)* Running at full load (equal to rated output) of the generator and the maximum electrical step load is suddenly thrown off;

In the case when a step load equivalent to the rated output of a generator is thrown off, a transient frequency variation in excess of 10% of the rated frequency may be acceptable, provided the overspeed protective device fitted in addition to the governor, as required by 4-2-1/7.5.3, is not activated.

- ii)* Running at no load and 50% of the full load of the generator is suddenly thrown on, followed by the remaining 50% after an interval sufficient to restore the frequency to steady state.

7.5.1(b) Where the electrical power system is fitted with a power management system and sequential starting arrangements, the application of loads in multiple steps of less than 50% of rated load in 4-2-1/7.5.1(a)ii) above may be permitted, provided it is in accordance with 4-2-1/Figure 7. The details of the power management system and sequential starting arrangements are to be submitted and its satisfactory operation is to be demonstrated to the Surveyor.

7.5.1(c) For diesel engines driving emergency generators, the requirements of 4-2-1/7.5.1(a)i) and 4-2-1/7.5.1(d) are to be met even when:

- i) Their total consumer load is applied suddenly, or
- ii) Their total consumer load is applied in steps, subject to:
 - The total load is supplied within 45 seconds since power failure on the main switchboard
 - The maximum step load is declared and demonstrated
 - The power distribution system is designed such that the declared maximum step loading is not exceeded
 - The compliance of time delays and loading sequence with the above is to be demonstrated at ship's trials.

7.5.1(d) The permanent frequency variation is to be within $\pm 5\%$ of the rated frequency at any load between no load and the full load.

FIGURE 7
Limiting Curves for Loading 4-stroke Diesel Engines
Step by Step from No-load to Rated Power as Function
of the Brake Mean Effective Pressure

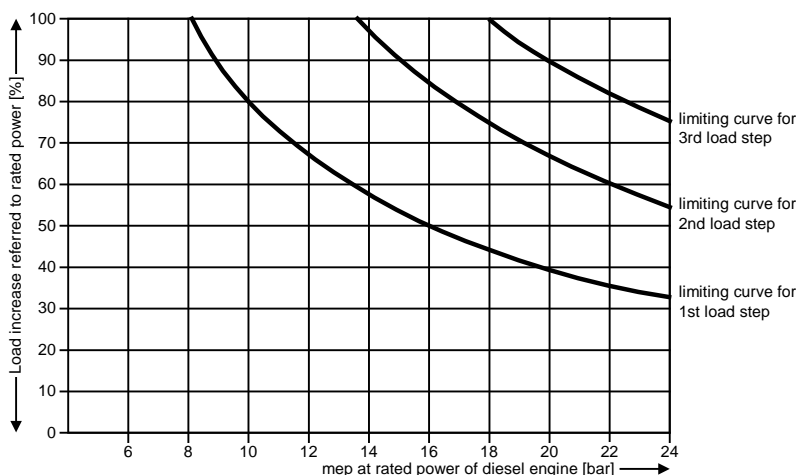

7.5.2 Generators in Parallel

For diesel engines driving AC generators that operate in parallel, the governor's characteristics are to be such that in the range between 20% and 100% of the combined rated load of all generators, the load on any individual generator will not differ from its proportionate share of the total combined load by more than 15% of the rated power of the largest generator or 25% of the individual generator, whichever is less.

Provisions are to be made to adjust the governors sufficiently fine in order to permit a load adjustment within the limits of 5% of the rated load at normal frequency.

7.5.3 Overspeed Protective Device

In addition to the governor, each engine driving an electric generator and having a rated power of 220 kW (295 hp) and over is to be fitted with a separate overspeed device so adjusted that the speed cannot exceed the maximum rated speed by more than 15%. Provision is to be made for hand tripping.

7.7 Materials other than Steel on Engine, Turbine and Gearbox Installations (1 July 2018)

7.7.1

Materials other than steel may be assessed in relation to the risk of fire associated with the component and its installation. The use of materials other than steel is considered acceptable for the following applications:

- i) Internal pipes which cannot cause any release of flammable fluid onto the machinery or into the machinery space in case of failure, or
- ii) Components that are only subject to liquid spray on the inside when the machinery is running, such as machinery covers, rocker box covers, camshaft end covers, inspection plates and sump tanks. It is a condition that the pressure inside these components and all the elements contained therein is less than 0.18 N/mm² and that wet sumps have a volume not exceeding 100 liters (26.4 gallons), or
- iii) Components attached to machinery which satisfy fire test criteria according to standard ISO 19921:2005/19922:2005 or other standards acceptable to the appropriate administration of the vessel's registry, and which retain mechanical properties adequate for the intended installation.

7.7.2

Aluminum and aluminum alloys may be considered for use in filters attached to engines where; either the engine installation is fitted with an effective fixed local application fire-extinguishing system in compliance with 4-7-2/1.11.2, or where the engine installation has a power rating not greater than 375 kW (500 hp). See also 4-6-2/3.5.

7.9 Auxiliary Blowers

Electrically driven auxiliary scavenging blowers that are only used for starting and operation at lower speeds of an engine may be accepted based on the following:

- i) At least two (2) independently driven scavenger blowers are provided,
- ii) Each blower is capable of supplying the required volume and pressure of scavenging air for the satisfactory operation of the engine over the range required. The required range is determined by the capabilities of the installed turbochargers (Section 4-2-2),
- iii) Auxiliary blowers may be shutdown at an appropriate engine speed to allow for quick passing through a barred speed range,
- iv) Capacity and vibration tests are carried out on each unit by the manufacturer, and
- v) Documentation verifying compliance with items ii) through iv) above is to be made available to the surveyor upon request.

Electric motors driving the above auxiliary scavenging blowers are to comply with Section 4-8-3 and are to be considered as a primary essential service in accordance with 4-8-1/Table 1, item (c).

7.11 Fire Extinguishing System for Scavenge Manifold

For crosshead type engines, scavenge spaces in open connection to the cylinder are to be permanently connected to an approved fire extinguishing system entirely separate from the fire extinguishing system of the engine room. A steam smothering system is acceptable for this purpose. Provisions for the design and installation of fixed fire-extinguishing system are in Section 4-7-3.

7.13 Warning Notices

7.13.1 Crankcase

To caution against opening hot crankcase, suitable warning notices are to be fitted, preferably on a crankcase door on each side of the engine or on the engine control stand. The notices are to specify a period of time for cooling after shutdown, based upon the size of the engine, but not less than 10 minutes in any case, before opening the door. Such notice is also to warn against restarting an overheated engine until the cause of overheating has been remedied.

7.13.2 Barred Speed Ranges

Where a barred speed range is specified in accordance with torsional vibration analysis, the engine speed indicator is to be so marked. A warning notice is to be fitted to the engine and at all local and remote propulsion control stations to the effect that operation in the barred range is to occur only while passing through the range and that operation within the barred range is to be avoided. See 4-3-2/7.5 for torsional vibration criteria.

7.15 Jacket Drain and Overpressure Protection

A drain cock is to be fitted at the lowest point of all cooling medium jackets. Means are to be provided to prevent the cooling medium jacket from being overpressurized. This will not be required if the cooling pump is of the centrifugal type, such that the no-flow pressure is no greater than the design pressure of the jacket.

7.17 Monitoring

Required monitoring for engine's fuel oil, lubricating oil, cooling water, starting air and exhaust gas systems are provided in the system requirements, see 4-2-1/9 below. For propulsion machinery spaces intended for centralized or unattended operation, engine and engine system monitoring and safety system functions are provided in Part 4, Chapter 9 (see e.g., 4-9-6/Table 1A and 4-9-6/Table 1B).

7.19 Engine Turning Gear

Where an engine turning gear arrangement is provided, an interlock is to be furnished so that the starting air system cannot be actuated when the turning gear is engaged.

9 Piping Systems for Diesel Engines

The requirements of piping systems, essential for operation of diesel engines intended for propulsion, maneuvering, electric power generation and vessel safety, are provided in Section 4-6-5. These systems include:

Fuel oil:	4-6-5/3
Lubricating oil:	4-6-5/5
Cooling water:	4-6-5/7
Starting air:	4-6-5/9
Electric starting:	4-8-2/11.11
Crankcase ventilation:	4-6-5/13
Exhaust gas:	4-6-5/11
Hydraulic and pneumatic systems:	4-6-7/3 and 4-6-7/5

11 Installation of Diesel Engines

11.1 Seating Arrangements for Diesel Engines

Diesel engines are to be securely supported and mounted to the vessel's structure by bolted connections with consideration given to all of the static and dynamic forces imposed by the engine.

11.3 Metal Chocks

Where metal chocks are used, they are to be made of forged steel, rolled steel or cast steel.

11.5 Cast Resin Chocks

Cast resin chocks of an approved type (see 1-1-A3/5 for type approval) may be used, provided that the arrangements and installation procedures are in accordance with the manufacturer's recommendations. Arrangements of the proposed installation, along with installation parameters such as engine deadweight, holding-down bolt tightening torque, etc., and calculations showing that the manufacturer's specified pressure is not exceeded, are to be submitted for review in each case.

11.7 Resilient Mountings

Resilient mountings may be used within the limits of the manufacturer's instructions and specifications for the resilient elements' elasticity and durability under shipboard ambient conditions.

11.9 Hot Surfaces

Hot surfaces likely to come into contact with the crew during operation are to be suitably guarded or insulated. Where the temperature of hot surfaces are likely to exceed 220°C (428°F), and where any leakage, under pressure or otherwise, of fuel oil, lubricating oil or other flammable liquid is likely to come into contact with such surfaces, they are to be suitably insulated with non-combustible materials that are impervious to such liquid. Insulation material not impervious to oil is to be encased in sheet metal or an equivalent impervious sheath.

13 Testing, Inspection and Certification of Diesel Engines

13.1 Material and Nondestructive Tests

For testing and nondestructive tests of materials intended for engine construction, see 4-2-1/3.1 and 4-2-1/3.3.

13.3 Hydrostatic Tests of Diesel Engine Components

Hydrostatic tests of diesel engine parts and components are to be in accordance with 4-2-1/Table 2. These tests are to be carried out by the manufacturer whose certificate of tests will be acceptable. However, independently driven pumps for fuel oil, lubricating oil, and cooling water services of diesel engines of bores exceeding 300 mm (11.8 in.) are required to be certified by the Surveyor; see 4-6-1/7.3.

13.5 Relief and Safety Valves

13.5.1 Crankcase Explosion Relief Valves

All crankcase explosion relief valves are to be type tested in accordance with Appendix 4-2-1A5. The type testing is to be conducted in the presence of an ABS Surveyor. Where the crankcase explosion relief valve is covered by a type approval this type testing can be waived, subject to concurrence by the attending Surveyor and the presentation of a document of conformity by the manufacturer to the Surveyor. The document of conformity is to confirm that the relief valves have been manufactured in accordance with the product design certificate associated with the type approval.

13.5.2 Safety Valves

Where provided, safety valves are to be tested and set in the presence of the Surveyor.

13.6 Manufacturer's Quality Control

13.6.1 Quality Plan

Prior to commencement of construction, the manufacturer is to submit to the Surveyor a quality plan setting out the quality control that it plans to perform on, but not limited to the following:

- issuance of material specifications for purchasing
- receiving inspection of materials
- receiving inspection of finished components and parts
- dimensional and functional checks on finished components and parts
- edge preparation and fit-up tolerances
- welding procedure qualification
- welding defect tracking
- NDT written procedures and qualification documentation
- NDT plan
- casting and weld defect resolutions
- assembly and fit specifications
- subassembly inspection: alignment and dimension checks, functional tests
- testing of safety devices

- welder qualification
 - hydrostatic testing plan
 - Weld inspection plan
 - engine test plan
- i) The engine manufacturer is to have a quality control system that is suitable for the actual engine types to be certified by the ABS. The quality control system is also to apply to any sub-suppliers. The ABS reserves the right to review the system or parts thereof. Materials and components are to be produced in compliance with all the applicable production and quality instructions specified by the engine manufacturer. The ABS requires that certain parts are verified and documented by means of Society Certificate (SC), Work Certificate (W) or Test Report (TR).
- ii) *Society Certificate (SC)*. This is a document issued by the ABS stating:
- Conformity with Rule requirements.
 - That the tests and inspections have been carried out on the certified product itself, or on samples taken from the certified product itself.
 - That the inspection and tests were performed in the presence of the Surveyor or in accordance with special agreements (i.e., ACS).
- iii) *Work's Certificate (W)*. This is a document signed by the manufacturer stating:
- Conformity with requirements.
 - That the tests and inspections have been carried out on the certified product itself, or on samples taken from the raw material, used for the product to be certified.
 - That the tests were witnessed and signed by a qualified representative of the applicable department of the manufacturer.
- A Work's Certificate may be considered equivalent to the ABS Certificate and endorsed by the ABS under the following cases:
- The test was witnessed by the ABS Surveyor; or
 - An Alternative Certification Scheme (ACS) agreement is in place between the ABS and the manufacturer or material supplier; or
 - The Work's certificate is supported by tests carried out by an accredited third party that is accepted by the ABS and independent from the manufacturer and/or material supplier.
- iv) *Test Report (TR)*. This is a document signed by the manufacturer stating:
- Conformity with requirements.
 - That the tests and inspections have been carried out on samples from the current production.
- v) The documents above are used for product documentation as well as for documentation of single inspections such as crack detection, dimensional check, etc. If agreed to by the ABS, the documentation of single tests and inspections may also be arranged by filling in results on a control sheet following the component through the production.
- vi) The Surveyor is to review the TR and W for compliance with the agreed or approved specifications. SC means that the Surveyor also witnesses the testing, batch or individual, unless an ACS provides other arrangements.
- vii) The manufacturer is not exempted from responsibility for any relevant tests and inspections of those parts for which documentation is not explicitly requested by the ABS.
- Manufacturing works is to be equipped in such a way that all materials and components can be consistently produced to the required standard. This includes production and assembly lines, machining units, special tools and devices, assembly and testing rigs as well as all lifting and transportation devices.

13.6.2 Welding on Engine Entablatures, Frames, Bedplates and Power Transmitting Component

13.6.2(a) Welding procedure. Before proceeding with welding, the manufacturer is to prove to the satisfaction of the Surveyor that the intended welding process, welding filler metal, preheat, post weld heat treatment, etc., as applicable, have been qualified for joining the base metal. In general, the intended welding procedure is to be supported by welding procedure qualification record (PQR) acceptable to or conducted in the presence of the Surveyor. The extent to which a PQR may be used to support multiple welding procedures is to be determined based on a recognized welding standard and is subject to acceptance by the Surveyor.

13.6.2(b) Welders and welding operators. Before proceeding with welding, the manufacturer is to prove to the satisfaction of the Surveyor that the welder or the welding operator is qualified for performing the intended welding procedure. In general, welders and welding operators are to be qualified in accordance with 2-4-3/11 in the presence of the Surveyor or supported by documented welder performance qualification records (WPQ) acceptable to the Surveyor. The extent to which a WPQ may be used to support multiple welding procedures is to be determined based on a recognized welding standard and is subject to acceptance by the Surveyor.

13.6.2(c) Facility-specific PQR and WPQ. To prove the capability of specific facilities, PQR and WPQ are to be conducted at and certified by the facilities where the fabrication or weld repair is to be conducted. PQR and WPQ conducted at other facilities are normally not acceptable for supporting the intended welding, without specific acceptance by the Surveyor.

13.6.2(d) Welding filler metals. All welding filler metals are to be certified by their manufacturers as complying with appropriate recognized national or international standards. Welding filler metals tested, certified and listed by ABS in its publication, *Approved Welding Consumables*, for meeting such a standard may be used in all cases. See Part 2, Appendix 2 for approval of filler metals. Welding filler metals not so listed may also be accepted provided that:

- i) They are of the same type as that proven in qualifying the welding procedure; and
- ii) They are of a make acceptable to the Surveyor; and
- iii) For welding of Group I engineering structures, representative production test pieces are to be taken to prove the mechanical properties of the weld metal.

13.6.2(e) Tack welds. Tack welds, where used, are to be made with filler metal suitable for the base metal. Tack welds intended to be left in place and form part of the finished weld are to be made by qualified welders using process and filler metal the same as or equivalent to the welding procedure to be used for the first pass. When preheating is required, the same preheating should be applied prior to tack welding.

13.6.2(f) Repair of defective welds. Any weld joint imperfection disclosed by examination in 4-2-1/13.6.3(c) and deemed unacceptable is to be removed by mechanical means or thermal gouging processes, after which the joint is to be welded using the appropriate qualified welding procedure by a qualified welder. Preheat and post-weld heat treatment is to be performed, as applicable. Upon completion of repair, the repaired weld is to be re-examined by the appropriate technique that disclosed the defect in the original weld.

13.6.2(g) Repair of castings by welding. Casting surface defects and defects revealed by nondestructive tests specified in 4-2-1/Table 1 and deemed unacceptable may be repaired by welding. All welding repairs are to be conducted using qualified welding procedure and by qualified welders as per 4-2-1/13.6.2(a), 4-2-1/13.6.2(b) and 4-2-1/13.6.2(c). The welding procedure, preheat and post weld heat treatment, as applicable, are to be in accordance with engine designer's specifications and supported by appropriate PQR. The Surveyor is to be notified prior to proceeding with the repair. Where welding repair is to be conducted at the foundry, the same procedure is to be adhered to. Defects detected by nondestructive tests required by 4-2-1/Table 1 are to be re-examined by at least the same technique after completion of repair.

13.6.3 Nondestructive Tests and Inspections

13.6.3(a) Qualification of procedures and operators. Before proceeding to conduct nondestructive tests required by 4-2-1/Table 1, the manufacturer is to have a written procedure for conducting each of these tests and for qualifying the operators intended for conducting these tests. Subcontractors, if employed for this purpose, are to be similarly qualified. In general, the processes of qualifying the procedures and the operators and the necessary technical supervision and training are to be in accordance with a recognized standard.

13.6.3(b) Nondestructive test procedures of engine parts. Parts requiring ultrasonic tests by 4-2-1/Table 1 are each to be provided with a test plan. Typically, for ultrasonic testing, the plan is to specify:

- part to be tested
- ultrasonic equipment
- couplant
- reference block(s)
- scanning coverage and rate
- calibration procedure
- acceptance standards

As a minimum, dye penetrant test plans are to specify the part to be tested, penetrant type and developer, procedure for retest, allowable ambient and test piece temperatures, and acceptance standards; and magnetic particle test plans are to specify parts to be tested, magnetization technique and equipment, surface preparation, type of ferromagnetic particles, and acceptance standards.

13.6.3(c) Nondestructive tests of welds. The manufacturer's quality plan for weld inspection should include visual inspection, measurement of weld sizes, as well as nondestructive tests (dye-penetrant, magnetic particle, radiography or ultrasonic), as may be specified by the engine designer for important structural parts.

13.6.3(d) Documentation. The manufacturer is to document and certify the results of the required nondestructive tests. The number and locations of unacceptable indications found are to be reported, together with corrective action taken, preferably on a sketch, along with questionable areas and any required areas not examined, where applicable.

13.6.3(e) Witness by Surveyor. All documents required in 4-2-1/13.6.3 are to be made available to the Surveyor. Where in doubt, or for purposes of verification, the Surveyor may request for a demonstration of any nondestructive tests required by 4-2-1/Table 1 to be conducted in his presence.

13.6.4 Assembly and Fit

The manufacturer's quality plan is to require checks on important fit, alignment, tolerances, pretensioning, etc. specified by the engine designers. Data measured in the as-assembled condition are to be recorded and made available to the Surveyor, who may request for verification of the recorded data.

13.7 Type Tests of Diesel Engines

13.7.1 Application

Each new type of diesel engine, as defined in 4-2-1/13.7.2, is to be type tested under the conditions specified in 4-2-1/13.7, except that mass-produced engines intended to be certified by quality assurance may be type tested in accordance with 4-2-1/13.11. The testing of the engine for the purpose of determining the rated power and 110% power is to be conducted at the ambient reference conditions given in 4-2-1/1.7 of the Rules, or power corrections are to be made. A type test carried out for a type of engine at any place of manufacture will be accepted for all engines of the same type built by licensees and licensors. A type test carried out on one engine having a given number of cylinders will be accepted for all engines of the same type having a different number of cylinders. However, a type test of an in-line engine may not always cover the V-version. Subject to the ABS discretion, separate type tests may be required for the V-version (a type test of a V-engine covers the in-line engines, unless the bmep is higher). Items such as axial crankshaft vibration, torsional vibration in camshaft drives, and crankshafts, etc. may vary considerably with the number of cylinders and may influence the choice of engine to be selected for type testing.

The type testing is to be arranged to represent typical foreseen service load profiles, as specified by the engine builder, as well as to cover for required margins due to fatigue scatter and reasonably foreseen in-service deterioration. This applies to:

- i)* Parts subjected to high cycle fatigue (HCF) such as connecting rods, cams, rollers and spring tuned dampers where higher stresses may be provided by means of elevated injection pressure, cylinder maximum pressure, etc.
- ii)* Parts subjected to low cycle fatigue (LCF) such as “hot” parts when load profiles such as idle - full load - idle (with steep ramps) are frequently used
- iii)* Operation of the engine at limits as defined by its specified alarm system, such as running at maximum permissible power with the lowest permissible oil pressure and/or highest permissible oil inlet temperature.

Where a previously approved engine of the conventional type (i.e., non-electronically controlled) is modified to be an electronically controlled engine, the requirement to conduct those tests specified in 4-2-1/13.7 which were already conducted as part of the conventional engine approval and for which it can be shown that the results would not be impacted due to the addition of the electronic controls, may be subject to special consideration.

13.7.2 Engine Type Definition

For purposes of type tests, a diesel engine “type”, as specified by the manufacturer’s type designation, is to be defined by:

- The working cycle (2-stroke, 4-stroke)
- The cylinder arrangement (in-line, vee)
- The rated power per cylinder at rated speed and mean effective pressure, see 4-2-1/13.7.3
- The kind of fuel (liquid, dual fuel, gaseous)
- The method of fuel injection (direct or indirect)
- The valve and injection operation (by cams or electronically controlled)
- The cylinder bore
- The stroke
- The scavenging system (naturally aspirated or supercharged)
- The supercharging system (constant or pulsating pressure)
- The charged air cooling system (provided with intercooler or not, number of cooling stages)

Engines may be considered the same type if they do not differ from any of the above items.

13.7.3 Increase in Rated Power

The engine is type approved up to the tested ratings and pressures (100% corresponding to MCR). Provided documentary evidence of successful service experience with the classified rating of 100% is submitted, an increase (if approved based on crankshaft calculation and crankshaft drawings) may be permitted without a new type test if the increase from the type tested engine is within:

- i)* 5% of the maximum combustion pressure, or
- ii)* 5% of the mean effective pressure, or
- iii)* 5% of the rpm.

Provided maximum power is not increased by more than 10%, an increase of maximum approved power may be permitted without a new type test provided engineering analysis and evidence of successful service experience in similar field applications or documentation of internal testing are submitted if the increase from the type tested engine is within:

- iv) 10% of the maximum combustion pressure, or
- v) 10% of the mean effective pressure, or
- vi) 10% of the rpm.

13.7.4 Type Tests

Each type test is subdivided into three stages:

- Stage A: manufacturer's tests; This includes some of the testing made during the engine development, function testing, and collection of measured parameters and records of testing hours. The results of testing required by ABS or stipulated by the designer are to be presented to the ABS before starting stage B.
- Stage B: type assessment tests to be conducted in the presence of a Surveyor;
- Stage C: component inspection after the test by a Surveyor.

The complete type testing program is subject to approval by the ABS. The extent the Surveyor's attendance is to be agreed in each case, but at least during stage B and C. Testing prior to the witnessed type testing (stage B and C), is also considered as a part of the complete type testing program. Upon completion of the type testing (stage A through C), a type test report is to be submitted to ABS for review. The type test report is to contain:

- i) Overall description of tests performed during stage A. Records are to be kept by the builders QA management for presentation to ABS;
- ii) Detailed description of the load and functional tests conducted during stage B;
- iii) Inspection results from stage C.

The type testing is to substantiate the capability of the design and its suitability for the intended operation. Special testing such as LCF and endurance testing will normally be conducted during stage A.

High speed engines for marine use are normally to be subjected to an endurance test of 100 hours at full load. Omission or simplification of the type test may be considered for the type approval of engines with long service experience from non-marine fields or for the extension of type approval of engines of a well-known type, in excess of the limits given in this section.

Propulsion engines for high speed vessels that may be used for frequent load changes from idle to full are normally to be tested with at least 500 cycles (idle - full load - idle) using the steepest load ramp that the control system (or operation manual if not automatically controlled) permits. The duration at each end is to be sufficient for reaching stable temperatures of the hot parts.

These stages are described in details as follows.

13.7.4(a) Stage A: manufacturer's tests. The manufacturer is to carry out functional tests in order to collect and record the engine's operating data. During these tests, the engine is to be operated at the load points specified by the engine manufacturer and the pertinent operating values are to be recorded. The load points may be selected according to the range of applications.

The tests are to include the normal and the emergency operating modes as specified below:

- i) *Normal operating mode.*

The load points 25%, 50%, 75%, 100% and 110% of the rated power for continuous operation:

- Along the nominal (theoretical) propeller curve and at constant rated speed for propulsion engines [if applicable mode of operation (i.e., driving controllable pitch propellers)];
- At constant rated speed for engines intended to drive electric generators including a test at no load and rated speed;

The limit points of the permissible operating range, as defined by the engine manufacturer.

For high speed engines, the 100 hr full load test and the low cycle fatigue test apply as required in connection with the design assessment.

Specific tests of parts of the engine stipulated by the designer.

ii) *Emergency operating mode.* The manufacturer's test for turbocharged engines is to include the determination of the maximum achievable continuous power output in the following cases of simulated turbocharger damage:

- Engines with one turbocharger: with the rotor blocked or removed;
- Engines with two or more turbochargers: with one turbocharger shut off.

13.7.4(b) *Stage B: type tests to be witnessed by the Surveyor.* The engine is to be operated at the load points shown in 4-2-1/Figure 8. The data measured and recorded at each load point is to include all necessary parameters for the engine operation.

i) The operating time per load point depends on the engine size (achievement of steady-state condition) and on the time for collection of the operating values. For 4-2-1/13.7.4(b)i) below, an operating time of two hours is required and two sets of readings are to be taken at a minimum interval of one hour. For 4-2-1/13.7.4(b)ii) through 4-2-1/13.7.4(b)vi) below, the operating time per load point is not to be less than 30 minutes.

- a) Rated power, i.e., 100% output at 100% torque and 100% speed corresponding to load point 1.
- b) 100% power at maximum permissible speed corresponding to load point 2.
- c) Maximum permissible torque (at least and normally 110%) at 100% speed corresponding to load point 3; or maximum permissible power (at least and normally 110%) and 103.2% speed according to nominal propeller curve corresponding to load point 3a. Load point 3a applies to engines only driving fixed pitch propellers or water jets. Load point 3 applies to all other purposes. Load point 3 (or 3a as applicable) is to be replaced with a load that corresponds to the specified overload and duration approved for intermittent use. This applies where such overload rating exceeds 110% of MCR. Where the approved intermittent overload rating is less than 110% of MCR, subject overload rating has to replace the load point at 100% of MCR. In such case the load point at 110% of MCR remains.
- d) Minimum permissible speed at 100% torque corresponding to load point 4.
- e) Minimum permissible speed at 90% torque corresponding to load point 5.
- f) Part load operation, e.g., 75%, 50%, 25% of maximum continuous rated power and speed according to the nominal propeller curve (i.e., 90.8%, 79.3% and 62.9% speed) corresponding to point 6, 7 and 8, or at constant rated speed setting corresponding to points 9, 10 and 11, depending on the intended application of the engine.
- g) Crosshead engines not restricted for use with C.P. propellers are to be tested with no load at the associated maximum permissible engine speed.

ii) For turbocharged engines, maximum achievable power when operating along the nominal propeller curve and when operating with constant governor setting for rated speed under the following conditions:

- a) Engines equipped with one turbocharger: with the rotor blocked or removed,
- b) Engines equipped with two or more turbochargers: with one turbocharger shut off. Engines intended for single propulsion with a fixed pitch propeller are to be able to run continuously at a speed (rpm) of 40% of full speed along the theoretical propeller curve when one turbocharger is out of operation.

- iii) Functional tests are to be performed for the following:
- a) The lowest engine speed according to the nominal propeller curve
 - b) The engine starting and reversing appliances, where applicable for the purpose of determining the minimum air pressure and the consumption for a start.
 - c) The speed governor
 - d) The safety system, particularly for overspeed and low lubricating oil pressure
 - e) *Integration Test:* For electronically controlled diesel engines, integration tests are to verify that the response of the complete mechanical, hydraulic and electronic system is as predicted for all intended operational modes. The scope of these tests is to be determined based on the FMEA as required in Appendix 4-2-1A1 of the Rules.
- iv) Verification of compliance with requirements for jacketing of high-pressure fuel oil lines, screening of pipe connections in piping containing flammable liquids and insulation of hot surfaces:
- a) The engine is to be inspected for jacketing of high-pressure fuel oil lines, including the system for the detection of leakage, and proper screening of pipe connections in piping containing flammable liquids.
 - b) Proper insulation of hot surfaces is to be verified while running the engine at 100% load, alternatively at the overload approved for intermittent use. Readings of surface temperatures are to be done by use of Infrared Thermoscanning Equipment. Equivalent measurement equipment may be used when so approved by ABS. Readings obtained are to be randomly verified by use of contact thermometers.

13.7.4(c) *Stage C: component inspection by the Surveyor.* The crankshaft deflections are to be measured in the specified (by designer) condition (except for engines where no specification exists). High speed engines for marine use are normally to be stripped down for a complete inspection after the type test. For all the other engines, after the test run, the following components of one cylinder for in-line and of two cylinders for V-engines are to be presented for the Surveyor's inspection (engines with long service experience from non-marine fields can have a reduced extent of opening):

- Piston removed and dismantled
- Crosshead bearing, dismantled
- Guide planes
- Connecting rod bearings (big and small end, special attention to serrations and fretting on contact surfaces with the bearing backsides) and main bearing, dismantled
- Cylinder liner in the installed condition
- Cylinder head, valves disassembled
- Control gear or chain, camshaft and crankcase with opened covers (the engine must be turnable by turning gear for this inspection)

For V-engines, the cylinder units are to be selected from both cylinder banks and different crank throws.

Further dismantling of the engine may be required by and at the discretion of the Surveyor.

13.7.4(d) *De-rated Engine.* If an engine has been design approved, and internal testing per Stage A is documented to a rating higher than the one type tested, the Type Approval may be extended to the increased power/mep/rpm upon submission of an Extended Delivery Test Report at:

- i) Test at over speed (only if nominal speed has increased)
- ii) Rated power, (i.e. 100% output at 100% torque and 100% speed corresponding to load point 1., 2 measurements with one running hour in between

iii) Maximum permissible torque (normally 110%) at 100% speed corresponding to load point 3 or maximum permissible power (normally 110%) and speed according to nominal propeller curve corresponding to load point 3a., 1/2 hour

iv) 100% power at maximum permissible speed corresponding to load point 2 1/2 hour

13.7.4(e) Integration Test. An integration test demonstrating that the response of the complete mechanical, hydraulic and electronic system is as predicted maybe carried out for acceptance of subsystems (Turbocharger, Engine Control System, Dual Fuel, Exhaust Gas treatment...) separately approved. The scope of these tests is to be proposed by the designer/licensor taking into account of impact on engine.

13.7.4(f) Measurements and Recordings. During all testing the ambient conditions (air temperature, air pressure and humidity) are to be recorded.-As a minimum, the following engine data are to be measured and recorded:

i) Engine rpm

ii) Torque

iii) Maximum combustion pressure for each cylinder*

iv) Mean indicated pressure for each cylinder*

v) Charging air pressure and temperature

vi) Exhaust gas temperature

vii) Fuel rack position or similar parameter related to engine load

viii) Turbocharger speed

ix) All engine parameters that are required for control and monitoring for the intended use (propulsion, auxiliary, emergency). Refer to 4-2-1/13.11.4

* *Note:* For engines where the standard production cylinder heads are not designed for such measurements, a special cylinder head made for this purpose may be used. In such a case, the measurements may be carried out as part of Stage A and are to be properly documented. Where deemed necessary (e.g., for dual fuel engines), the measurement of maximum combustion pressure and mean indicated pressure may be carried out by indirect means, provided the reliability of the method is documented. Calibration records for the instrumentation used to collect data as listed above are to be presented to and reviewed by the attending Surveyor. Additional measurements may be required in connection with the design assessment.

13.7.4(g) Safety Precautions. Before any test run is carried out, all relevant equipment for the safety of attending personnel is to be made available by the manufacturer/shipyard and is to be operational, and its correct functioning is to be verified. This applies especially to crankcase explosive conditions protection, but also over-speed protection and any other shut down function. The inspection for jacketing of high-pressure fuel oil lines and proper screening of pipe connections is also to be carried out before the test runs. Interlock test of turning gear is to be performed when installed.

13.7.5 Additional Tests

For engines intended to be used for emergency services, supplementary tests according to the regulations of the Administration whose flag the vessel flies may be required.

FIGURE 8
Type Test Power/Speed Diagram

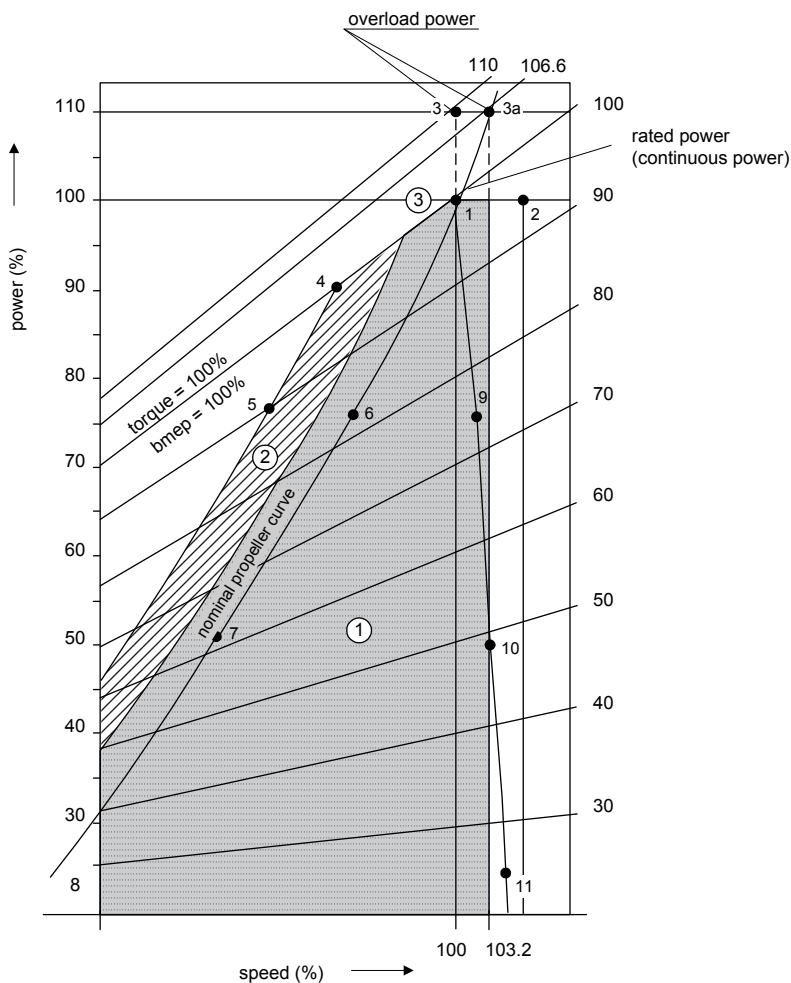

- ① = range of continuous operation
- ② = range of intermittent operation
- ③ = range of short-time overload operation

13.9 Shop Tests of Internal Combustion, I.C. Engines

Before any test run is carried out, all required safety devices are to be installed by the manufacturer / shipyard and are to be operational. This applies especially to crankcase explosive conditions protection, but also to over-speed protection and any other shut down function. The overspeed protective device is to be set to a value, which is not higher than the overspeed value that was demonstrated during the type test for that engine. This set point is to be verified by the Surveyor.

13.9.1 General

The operational data corresponding to each of the specified test load conditions are to be determined and recorded and all results are to be compiled in an acceptance protocol to be issued by the engine manufacturer. This also includes crankshaft deflections if considered necessary by the engine designer. Calibration records for the instrumentation are to be presented to the attending Surveyor. In each case, all measurements conducted at the various load points shall be carried out at steady operating conditions. The readings for 100% power (rated power at rated speed) are to be taken twice at an interval of at least 30 minutes.

13.9.1(a) *Environmental Test Conditions.* The following environmental test conditions are to be recorded

- i) Ambient air temperature
- ii) Ambient air pressure
- iii) Atmospheric humidity

13.9.1(b) *Load Points.* For each required load point, the following parameters are to be recorded:

- i) Power and speed
- ii) Fuel index (or equivalent reading)
- iii) Maximum combustion pressures (only when the cylinder heads installed are designed for such measurement)
- iv) Exhaust gas temperature before turbine and from each cylinder (to the extent that monitoring is required in this Section and in Section 4-2-2)
- v) Charge air temperature
- vi) Charge air pressure
- vii) Turbocharger speed (to the extent that monitoring is required in Section 4-2-2)

Before any official testing, the engines shall be run-in as prescribed by the engine manufacturer. Adequate test bed facilities for loads as required in this section are to be provided. All fluids used for testing purposes such as fuel, lubrication oil and cooling water are to be suitable for the purpose intended (e.g., they are to be clean, preheated if necessary and cause no harm to engine parts). This applies to all fluids used temporarily or repeatedly for testing purposes only.

13.9.1(c) *Inspections.* Engines are to be inspected for:

- i) Jacketing of high-pressure fuel oil lines including the system used for the detection of leakage
- ii) Screening of pipe connections in piping containing flammable liquids
- iii) Insulation of hot surfaces by taking random temperature readings that are to be compared with corresponding readings obtained during the type test. This shall be done while running at the rated power of engine. Use of contact thermometers may be accepted at the discretion of the attending Surveyor. If the insulation is modified subsequently to the Type Approval Test, the ABS may request temperature measurements.

These inspections are normally to be made during the Shop trials by the manufacturer and the attending surveyor, but at the discretion of the ABS parts of these inspections may be postponed to the shipboard testing.

Test loads for various engine applications are given below. In addition, the scope of the trials may be expanded depending on the engine application, service experience, or other relevant reasons. Alternatives to the detailed tests may be agreed between the manufacturer and the ABS when the overall scope of tests is found to be equivalent.

13.9.2 Engines Driving Propellers or Impellers Only

Main propulsion engines driving propellers are to be tested under the following conditions:

- i) 100% of rated power (MCR) at rated engine speed (n_o), for at least 60 minutes
- ii) 110% of rated power at an engine speed of $n = 1.032n_o$. Records to be taken after 15 minutes or after having reached steady conditions, whichever is shorter.

Note: Only required once for each different engine/turbocharger configuration.

- iii) Approved intermittent overload (if applicable): testing for duration as agreed with the manufacturer.

- iv) 90% (or normal continuous cruise power), 75%, 50% and 25% of rated power, in accordance with the nominal propeller curve (the sequence to be selected by the engine manufacturer).
- v) Starting and reversing maneuvers.
- vi) After running on the test bed, the fuel delivery system of the engine is to be adjusted so that the engine output is limited to the rated power and so that the engine cannot be overloaded under service condition, unless intermittent overload power is approved by the ABS. In that case, the fuel delivery system is to be blocked to that power.
- vii) Testing of governor and independent overspeed protective device.
- viii) Testing of shutdown device.

13.9.3 Engines Driving Generators Dedicated for Propulsion Motors

For engines intended for driving electric propulsion generators, the tests are to be performed at the rated speed with a constant governor setting under the following conditions:

- i) 100% rated power for at least 60 min.
- ii) 110% of rated power for 15 min., after having reached steady conditions.
- iii) After running on the test bed, the fuel delivery system of the engine is to be adjusted so that an overload power of 110% of the rated power can be supplied. Due regard is to be given to service conditions after installation on board and to the governor characteristics, including the activation of generator protective devices. See also 4-2-1/7.5.1(b) for governor characteristics associated with power management systems.
- iv) 75%, 50% and 25% of rated power and idle run (the sequence to be selected by the engine manufacturer).
- v) Start-up tests.
- vi) Testing of governor and independent overspeed protective device.
- vii) Testing of shutdown device.

13.9.4 Engines Driving Generators for Auxiliary Purposes (1 July 2018)

Engines intended for driving vessel service generators and emergency generators, are to be tested as specified in 4-2-1/13.9.3. After running on the test bed, the fuel delivery system of the engine is to be adjusted so that an overload power of 110% of the rated power can be supplied. Due regard is to be given to service conditions after installation on board and to the governor characteristics including the activation of generator protective devices. See also 4-2-1/7.5.1(b) for governor characteristics associated with power management systems.

13.9.5 Propulsion Engines also Driving Power Take Off (PTO) Generator

For propulsion engines driving a generator through a power take off the following tests are to be performed:

- i) 100% rated power at corresponding speed n_o for at least 60 min.
- ii) 110% power at engine speed n_0 for 15 min., after having reached steady conditions.
- iii) Approved intermittent overload (if applicable): testing for duration as agreed with the manufacturer.
- iv) 90% (or normal continuous cruise power), 75%, 50% and 25% power in accordance with the nominal propeller curve or at constant speed n_o , the sequence to be selected by the engine manufacturer.

After running on the test bed, the fuel delivery system is to be adjusted so that full power plus a margin for transient regulation can be given in service after installation onboard. The transient overload capability is required so that the electrical protection of downstream system components is activated before the engine stalls. This margin may be 10% of the engine power but at least 10% of the PTO power.

13.9.6 Engines Driving Auxiliaries

For engines driving auxiliaries the following tests are to be performed:

- i) 100% rated power at corresponding speed n_o for at least 30 min.
- ii) 110% power at engine speed n_o for 15 min., after having reached steady conditions.
- iii) Approved intermittent overload (if applicable): testing for duration as agreed with the manufacturer.
- iv) For variable speed engines, 75%, 50% and 25% power in accordance with the nominal power consumption curve, the sequence to be selected by the engine manufacturer.

After running on the test bed, the fuel delivery system is normally to be so adjusted that overload power cannot be delivered in service, unless intermittent overload power is approved. In that case, the fuel delivery system is to be blocked to that power.

13.9.7 Turbocharger Matching with Engine

13.9.7(a) Compressor Chart. Turbochargers are to have a compressor characteristic that allows the engine, for which it is intended, to operate without surging during all operating conditions and also after extended periods in operation. For abnormal, but permissible, operation conditions, such as misfiring and sudden load reduction, no continuous surging is to occur.

Surging means the phenomenon, which results in a high pitch vibration of an audible level or explosion-like noise from the scavenger area of the engine.

Continuous surging means that surging happens repeatedly and not only once.

13.9.7(b) Surge Margin Verification. Turbochargers over 2500 kW used on propulsion engines are to be checked for surge margins during the engine workshop testing as specified below. These tests may be waived if successfully tested earlier on an identical configuration of engine and turbocharger (including same nozzle rings).

13.9.7(c) 4-stroke Engines. For 4-stroke engines, the following is to be performed without indication of surging:

- i) With maximum continuous power and speed (= 100%), the speed is to be reduced with constant torque (fuel index) down to 90% power.
- ii) With 50% power at 80% speed (= propeller characteristic for fixed pitch), the speed is to be reduced to 72% while keeping constant torque (fuel index).

13.9.7(d) 2-stroke Engines. For 2-stroke engines, the surge margin is to be demonstrated by at least one of the following methods:

- i) The engine working characteristic established at workshop testing of the engine is to be plotted into the compressor chart of the turbocharger (established in a test rig). There is to be at least 10% surge margin in the full load range (i.e., working flow is to be 10% above the theoretical (mass) flow at surge limit (at no pressure fluctuations)).
- ii) Sudden fuel cut-off to at least one cylinder is not to result in continuous surging and the turbocharger is to be stabilized at the new load within 20 seconds. For applications with more than one turbocharger the fuel is to be cut-off to the cylinders closest upstream to each turbocharger. This test is to be performed at two different engine loads:
 - a) The maximum power permitted for one cylinder misfiring;
 - b) The engine load corresponding to a charge air pressure of about 0.6 bar (but without auxiliary blowers running).
- iii) No continuous surging and the turbocharger is to be stabilized at the new load within 20 seconds when the power is abruptly reduced from 100% to 50% of the maximum continuous power.

13.9.8 Electronically Controlled Engines

For electronically controlled engines, integration tests are to be conducted. They are to verify that the response of the complete mechanical, hydraulic and electronic system is as predicted for all intended operational modes. The scope of these tests is to be determined based on those tests that have been established for the type testing. If such tests are technically unfeasible at the works, these tests may be conducted during sea trial. The scope of these tests is to be agreed with the ABS for selected cases based on the FMEA required in this Section.

13.9.9 Inspection After Tests

After shop tests, engine components, randomly selected at the discretion of the Surveyor, are to be presented for inspection. Where engine manufacturers require crankshaft deflection to be periodically checked during service, the crankshaft deflection is to be measured at this time after the shop test and results recorded for future reference.

13.11 Type Tests of Mass-produced Diesel Engines

13.11.1 Application

13.11.1(a) General. Each type of diesel engine mass produced (see 4-2-1/13.11.2) under the accepted quality assurance program is to be type tested in accordance with the provisions of 4-2-1/13.11. A type test carried out for a type of engine at a place of manufacture will be accepted for all engines of the same type built by licensees and licensors. A type test carried out on one engine having a given number of cylinders will qualify all engines of the same type having a different number of cylinders. The type test is to be conducted in the presence of the Surveyor.

Consideration will be given to modification of the type test requirements for existing engine designs which have proven reliability in service.

13.11.1(b) Alternative Certification Scheme (ACS). Mass produced diesel engines may be eligible for certification under ACS program as outline in 1-1-A3/5.5.

13.11.2 Definition of Mass Production of Diesel Engines

A diesel engine intended for propulsion or auxiliary service is considered mass-produced if it meets the following criteria:

- The engines are produced in quantity.
- The materials and components used for the construction of the engines are manufactured in accordance with approved quality control procedures specified by the engine builder.
- The machinery used for manufacturing of the engine components is specially calibrated and subject to regular inspection in order to meet the engine builder's specifications and quality requirements and to allow for assembly or interchangeability of components without any re-machining.
- Each assembled engine undergoes a bench test in accordance with specified procedures.
- Final testing, in accordance with specified procedures, is carried out on engines selected at random after bench testing.

13.11.3 Tests to be Witnessed by the Surveyor

13.11.3(a) Load points:

- i) 80 hours at rated power;
- ii) 8 hours at 110% overload and alternately 100% rpm and 103% rpm;
- iii) 10 hours at partial loads (in steps of 90%, 75%, 50% and 25% of rated power);
- iv) 2 hours at intermittent loads.

The tests are to be conducted in cycles, with each cycle comprising all of the above load points, and the cycle repeated until the specified durations of the tests are achieved.

13.11.3(b) *Functional tests:*

- i) The engine starting and reversing appliances,
- ii) The speed governor,
- iii) The overspeed device,
- iv) The lubricating oil failure indication device,
- v) The condition of turbocharger out of action (where applicable),
- vi) Running at minimum speed for main propulsion engines and at idle speed for auxiliary engines.

13.11.3(c) *Component inspection.* After the type test, all main parts of the engine are to be dismantled and examined by the Surveyor.

13.11.4 Measurements and Recordings

The following particulars are to be measured and recorded:

Ambient test conditions:

- Air temperature
- Barometric pressure
- Relative humidity
- External cooling water temperature
- Characteristics of fuel and lubricating oil

Engine measurements:

- Engine power
- Engine rpm
- Torque or brake load
- Maximum combustion pressure (indicator diagram where practicable)
- Exhaust smoke
- Lubricating oil pressure and temperature
- Cooling water pressure and temperature
- Exhaust gas temperature in exhaust manifold and, if possible, at each cylinder outlet and for supercharged engines
- Turbocharger rpm
- Air pressure and temperature at inlet and outlet of turbocharger and cooler
- Exhaust gas pressure and temperature at inlet and outlet of exhaust gas turbine and charge air cooler
- Cooling water temperature at charge air cooler inlet

Results of examination done after type tests: This should include disassembling and examination of the main parts and the parts subject to wear.

13.11.5 Additional Tests

For engines intended for different purposes and having different performances for each purpose, the type test program is to be extended to cover each performance under consideration of the most severe condition.

13.13 Certification of Diesel Engine

13.13.1 General

Each diesel engine required to be approved and certified by 4-2-1/1.1 is:

- i) To have a type approval certificate to be obtained by the engine designer. The process details for obtaining a type approval certificate are in 4-2-1A1/4, and
- ii) To have an engine certificate for a shipboard application. The process details for obtaining the engine certificate are in 4-2-1A1/5.

13.13.2 Certification Under Type Approval Program

13.13.2(a) Product design assessment. Upon application by the manufacturer, each model of a type of diesel engine may be design assessed as described in 1-1-A3/5.1. For this purpose, each design of an engine type is to be approved in accordance with 4-2-1/13.13.1i). Engines so approved may be applied to ABS for listing on the ABS website in the Design Approved Products Index [see 1-1-A3/5.1 (DA)]. Once listed, and subject to renewal and updating of certificate as required by 1-1-A3/5.7, engine particulars will not be required to be submitted to ABS each time the engine is proposed for use on board a vessel.

13.13.2(b) Mass produced engines. Manufacturer of mass-produced engines, who operates a quality assurance system in the manufacturing facilities, may apply to ABS for a quality assurance assessment, described in 1-1-A3/5.5 (PQA).

Upon satisfactory assessment under 1-1-A3/5.5 (PQA), engines produced in those facilities will not require a Surveyor's attendance at the tests and inspections indicated in 4-2-1/13.13.1ii) and 4-2-1/13.13.1iii). Such tests and inspections are to be carried out by the manufacturer whose quality control documents will be accepted. Certification of each engine will be based on verification of approval of the design and on continued effectiveness of the quality assurance system. See 1-1-A3/5.7.1(a).

13.13.2(c) Non-mass Produced Engines. Manufacturer of non-mass produced engines, who operates a quality assurance system in the manufacturing facilities, may apply to ABS for a quality assurance assessment, described in 1-1-A3/5.3.1(a) (Manufacturers Procedure) and 1-1-A3/5.3.1(b) (RQS). Certification to 1-1-A3/5.5 (PQA) may also be considered in accordance with 4-1-1/Table 1.

13.13.2(d) Type Approval Program. Engine types which have their designs approved in accordance with 4-2-1/13.13.2(a) and the quality assurance system of their manufacturing facilities approved in accordance with 4-2-1/13.13.2(b) or 4-2-1/13.13.2(c) will be deemed Type Approved and will be eligible for listing on the ABS website as Type Approved Products.

15 Shipboard Trials of Diesel Engines

After the conclusion of the running-in program, diesel engines are to undergo shipboard trials in the presence of a Surveyor, in accordance with the following procedure. Tests other than those listed below may be required by statutory instruments (e.g., EEDI verification).

15.1 Engines Driving Fixed Pitch Propellers or Impellers

For main propulsion engines directly driving fixed pitch propellers or impellers, the following running tests are to be carried out:

- i) At rated engine speed (n_o) for at least 4 hours.
- ii) At engine speed corresponding to the normal continuous cruising power for at least 2 hours.
- iii) At engine speed $n = 1.032n_o$ for 30 minutes (where engine adjustment permits).
- iv) At minimum on-load speed (minimum engine speed to be determined).
- v) Starting and reversing maneuvers.

- vi) Testing of the monitoring and safety systems.
- vii) At approved intermittent overload (if applicable): testing for duration as agreed with the manufacturer

During stopping tests according to Resolution MSC.137 (76), see 4-2-1/15.11 for additional requirements in the case of a barred speed range.

15.3 Engines Driving Controllable Pitch Propellers

For main propulsion engines driving controllable pitch propellers or reversing gears, the tests as per 4-2-1/15.1 apply, as appropriate. In addition, controllable pitch propellers are to be tested with various propeller pitches. With reverse pitch suitable for maneuvering, see 4-2-1/15.11 for additional requirements in the case of a barred speed range.

15.5 Engines Driving Propulsion Generators, Main Power Supply Generators and/or Emergency Generators

The running tests are to be carried out at the rated speed under the following conditions:

- i) At 100% power (rated electrical power of generator) for at least 60 min.
- ii) At 110% power (rated electrical power of generator) for at least 10 min.

Each engine is to be tested at 100% electrical power for at least 60 min and 110% of rated electrical power of the generator for at least 10 min. This may, if possible, be done during the electrical propulsion plant test, which is required to be tested with 100% propulsion power (i.e., total electric motor capacity for propulsion) by distributing the power on as few generators as possible. The duration of this test is to be sufficient to reach stable operating temperatures of all rotating machines or for at least 4 hours. When some of the genset(s) cannot be tested due to insufficient time during the propulsion system test mentioned above, those required tests are to be carried out separately.

- iii) Demonstration of the generator prime movers' and governors' ability to handle load steps as described in 4-2-1/7.5.

15.6 Propulsion Engines also Driving Power Take Off (PTO) Generator

The running tests are to be carried out at the rated speed, under the following conditions:

- i) 100% engine power (MCR) at corresponding speed n_o for at least 4 hours.
- ii) 100% propeller branch power at engine speed n_o (unless already covered in the above test) for 2 hours.
- iii) 100% PTO branch power at engine speed n_o for at least 1 hour.

15.7 Engines Driving Auxiliaries

Engines driving auxiliaries are to be subjected to an operational test at 100% power (MCR) at corresponding speed n_o for at least 30 min, and at approved intermittent overload (testing for duration as approved).

15.9 Engines Burning Residual Fuel Oil or Other Special Fuel Oils

The suitability of propulsion and auxiliary diesel engines to burn residual fuel oils or other special fuel oils, where they are intended to burn such fuel oils in service, is to be demonstrated.

15.11 Torsional Vibration Barred Speed Range

Where torsional vibration analyses indicate that a torsional vibration critical is within the engine operating speed range, the conduct of torsionograph tests and marking of the barred speed range, as appropriate, are to be carried out in accordance with 4-3-2/11.3.1. See also 4-2-1/7.13.2.

Where a barred speed range (bsr) is required, passages through this bsr, both accelerating and decelerating, are to be demonstrated. The times taken are to be recorded and are to be equal to or below those times stipulated in the approved documentation, if any. This also includes when passing through the bsr in reverse rotational direction, especially during the stopping test.

Notes:

- 1 Applies both for manual and automatic passing-through systems;
- 2 The ship's draft and speed during all these demonstrations is to be recorded. In the case of a controllable pitch propeller, the pitch is also to be recorded.
- 3 The engine is to be checked for stable running (steady fuel index) at both upper and lower borders of the bsr. Steady fuel index means an oscillation range less than 5% of the effective stroke (idle to full index).

TABLE 1
Required Material and Nondestructive Tests of Diesel Engine Parts⁽¹⁾

Engine Part	Material Properties ⁽²⁾	Nondestructive Tests & Inspections		Visual Inspection and Component Certificate	
		Magnetic Particle, Liquid Penetrant, or Similar Tests, Ultrasonic Tests	Dimensional Inspection, Including Surface Condition	Visual Inspection (Surveyor)	Component Certificate
Welded bedplate	W(C+M)	W(UT+CD)		fit-up + post welding	SC
Bearing transverse girders GS	W(C+M)	W(UT+CD)		X	SC
Welded frame box	W(C+M)	W(UT+CD)		fit-up + post welding	SC
Cylinder block GJL (crosshead engines)					
Cylinder block GJS (crosshead engines)					
Welded cylinder frames (crosshead engines)	W(C+M)	W(UT+CD)		fit-up + post welding	SC
Engine block GJS > 400 kW/cyl.	W(M)				
Cylinder liner D > 300 mm	W(C+M)				
Cylinder head GS D > 300 mm	W(C+M)	W(UT+CD)		X	SC
Forged cylinder head D > 300 mm	W(C+M)	W(UT+CD)		X	SC
Piston crown GS D > 400 mm	W(C+M)	W(UT+CD)		X	SC
Forged piston crown D > 400 mm	W(C+M)	W(UT+CD)		X	SC
Crankshaft: made in one piece	SC(C+M)	W(UT+CD)	W	Random, of fillets and oil bores	SC
Semi-built crankshaft	As below	As below	As below	As below	SC
Crank throw	SC(C+M)	W(UT+CD)	W	Random, of fillets and shrink fittings	
Forged main journal and journals with flange	SC(C+M)	W(UT+CD)	W	Random, of shrink fittings	
Piston rod D > 400 mm	SC(C+M)	W(UT+CD) CD again after final machining (grinding)		Random	SC
Cross head (crosshead engines)	SC(C+M)	W(UT+CD) CD again after final machining (grinding and polishing)		Random	SC
Connecting rod with cap	SC(C+M)	W(UT+CD)	W	Random, of all surfaces, in particular those shot peened	SC
Coupling bolts for crankshaft	SC(C+M)	W(UT+CD)	W	Random, of interference fit	SC
Bolts and studs for main bearings D > 300 mm	W(C+M)	W(UT+CD)			

TABLE 1 (continued)
Required Material and Nondestructive Tests of Diesel Engine Parts⁽¹⁾

Engine Part	Material Properties ⁽²⁾	Nondestructive Tests & Inspections		Visual Inspection and Component Certificate	
		Magnetic Particle, Liquid Penetrant, or Similar Tests, Ultrasonic Tests	Dimensional Inspection, Including Surface Condition	Visual Inspection (Surveyor)	Component Certificate
Bolts and studs for cylinder heads D > 300 mm	W(C+M)	W(UT+CD)			
Bolts and studs for connecting rods D > 300 mm	W(C+M)	W(UT+CD)	TR of thread making		
Tie rod (crosshead engines)	W(C+M)	W(UT+CD)	TR of thread making	Random	SC
High pressure fuel injection pipes including common fuel rail	W(C+M)				
High pressure common servo oil system	W(C+M)				
Cooler, both sides D > 300 mm	W(C+M)				
Accumulator of common rail fuel or servo oil system All engines with accumulators with a capacity of > 0.5 l	W(C+M)				
Piping, pumps, actuators, etc., for hydraulic drive of valves, if applicable > 800 kW/cyl.	W(C+M)				
Bearings for main, crosshead, and crankpin > 800 kW/cyl.	TR(C)	TR (UT for full contact between basic material and bearing metal)	W		

Symbol Description:

C: chemical composition; CD: crack detection by MPI or DP; D: cylinder bore diameter (mm); GJL: gray cast iron; GJS: spheroidal graphite cast iron; GS: cast steel; M: mechanical properties; SC: class certificate; TR: test report; UT: ultrasonic testing; W: work certificate; X: visual examination of accessible surfaces by the Surveyor.

Notes:

- 1 For engines < 375 kW, see 4-2-1/3.3.3.
- 2 Material properties include chemical composition and mechanical properties, and also surface treatment such as surface hardening (hardness, depth and extent), peening and rolling (extent and applied force).

TABLE 2
Test Pressures for Parts of Internal-combustion Engines

<i>Engine Part</i>	<i>Test Pressure</i> (<i>P = max. working pressure of engine part</i>)
Engine block GJL > 400 kW/cyl	1.5P
Cylinder cover, cooling space	7 bar (7 kgf/cm ² , 100 psi)
Cylinder liner, over the whole length of cooling space ⁽¹⁾	7 bar (7 kgf/cm ² , 100 psi)
Cylinder jacket, cooling space ⁽¹⁾	4 bar (4 kgf/cm ² , 58 psi) but not less than 1.5P
Exhaust valve, cooling space	4 bar (4 kgf/cm ² , 58 psi) but not less than 1.5P
Piston crown, cooling space, where the cooling space is sealed by piston rod or by piston rod and skirt (test after assembly). For forged piston crowns test methods other than pressure testing may be used, e.g., nondestructive examination and dimensional checks.	7 bar (7 kgf/cm ² , 100 psi)
Fuel-injection system (pump body pressure side, injection valves –only for those not autofretted – and pipes including common fuel rail, for those that are not autofretted), D > 300 mm, Test Report for D ≤ 300 mm.	1.5P or P + 300 bar (P + 306 kgf/cm ² , P + 4350 psi) whichever is less
High pressure common servo oil system (D > 300 mm, Test Report for D ≤ 300 mm), high pressure piping, pumps, actuators etc. for hydraulic drive of valves (> 800 kW/cyl.)	1.5P
Accumulator > 0.5l of common rail fuel or servo oil system	1.5P
Scavenge-pump cylinder	4 bar (4 kgf/cm ² , 58 psi)
Turbocharger, cooling space (see 4-2-2/11.1.3)	4 bar (4 kgf/cm ² , 58 psi) but not less than 1.5P
Exhaust pipe, cooling space	4 bar (4 kgf/cm ² , 58 psi) but not less than 1.5P
Engine-driven air compressor, (cylinders, covers, intercoolers and aftercoolers) air side	1.5P
Engine-driven air compressor, (cylinders, covers, intercoolers and aftercoolers) water side	4 bar (4 kgf/cm ² , 58 psi) but not less than 1.5P
Coolers, each side (charge air coolers need only be tested on the water side)	4 bar (4 kgf/cm ² , 58 psi) but not less than 1.5P
Engine driven pumps (oil, water, fuel, bilge), > 800 kW/cyl.	4 bar (4 kgf/cm ² , 58 psi) but not less than 1.5P
Independently driven pumps (oil, water, fuel) for engines with bores > 300 mm (11.8 in.)	1.5P, for certification of pumps; see 4-6-1/7.3.

Note:

- 1 Hydraulic testing is also required for those parts filled with cooling water and having the function of containing the water which is in contact with the cylinder or cylinder liner (D > 300 mm).

PART

4

CHAPTER 2 Prime Movers

SECTION 1 Appendix 1 – Approval of Diesel Engines

1 Scope

The documents necessary to approve a diesel engine design for conformance to the Rules and for use during manufacture and installation are listed. The document flow between engine designer, ABS Engineering, engine builder/licensee and ABS Survey is provided.

3 Definitions

Definitions relating to approval of diesel engines are given in 4-2-1A1/Annex 1.

5 Overview

5.1 Approval Process

5.1.1 Type Approval Certificate

For each type of engine that is required to be approved, a type approval certificate is to be obtained by the engine designer. The process details for obtaining a type approval certificate are in 4-2-1A1/7. This process consists of the engine designer obtaining:

- Drawing and specification approval,
- Conformity of production,
- Approval of type testing program,
- Type testing of engines,
- Review of the obtained type testing results, and
- Evaluation of the manufacturing arrangements,
- Issue of a type approval certificate upon satisfactorily meeting the Rule requirements.

5.1.2 Engine Certificate

Each diesel engine manufactured for a shipboard application is to have an engine certificate. The certification process details for obtaining the engine certificate are in 4-2-1A1/9. This process consists of the engine builder/licensee obtaining design approval of the engine application specific documents, submitting a comparison list of the production drawings to the previously approved engine design drawings referenced in 4-2-1A1/5.1.1, forwarding the relevant production drawings and comparison list for the use of the Surveyors at the manufacturing plant and shipyard if necessary, engine testing and upon satisfactorily meeting the Rule requirements, the issuance of an engine certificate.

5.3 Document Flow for Diesel Engines

5.3.1 Document Flow for Obtaining a Type Approval Certificate*

5.3.1(a) For the initial engine type, the engine designer prepares the documentation in accordance with requirements in 4-2-1A1/Table 1 and 4-2-1A1/Table 2 and forwards to the ABS according to the agreed procedure for review.

5.3.1(b) Upon review and approval of the submitted documentation (evidence of approval), it is returned to the engine designer.

5.3.1(c) The engine designer arranges for an ABS Surveyor to attend an engine type test and upon satisfactory testing the ABS issues a type approval certificate.

5.3.1(d) A representative document flow process for obtaining a type approval certificate is shown in 4-2-1A1A2/Figure 1.

* *Note:* Process of type approval certificate for diesel engines are equivalent as a product design assessment certificate under ABS Type Approval Program.

5.3.2 Document Flow for Engine Certificate**

5.3.2(a) The engine type must have a type approval certificate. For the first engine of a type, the type approval process and the engine certification process (ECP) may be performed simultaneously.

5.3.2(b) Engines to be installed in specific applications may require the engine designer/licensor to modify the design or performance requirements. The modified drawings are forwarded by the engine designer to the engine builder/licensee to develop production documentation for use in the engine manufacture in accordance with 4-2-1A1/Table 3.

5.3.2(c) The engine builder/licensee develops a comparison list of the production documentation to the documentation listed in 4-2-1A1/Table 1 and 4-2-1A1/Table 2. An example comparison list is provided in 4-2-1A1/Annex 4. If there are differences in the technical content on the licensee's production drawings/documents compared to the corresponding licensor's drawings, the licensee must obtain agreement to such differences from the licensor using the template in 4-2-1A1/Annex 5.

If the designer acceptance is not confirmed, the engine is to be regarded as a different engine type and is to be subjected to the complete type approval process by the licensee.

5.3.2(d) The engine builder/licensee submits the comparison list and the production documentation to the ABS according to the agreed procedure for review/approval.

5.3.2(e) The ABS returns documentation to the engine builder/licensee with confirmation that the design has been approved. This documentation is intended to be used by the engine builder/licensee and their subcontractors and attending ABS Surveyors. As the attending Surveyors may request the engine builder/licensee or their subcontractors to provide the actual documents indicated in the list, the documents are necessary to be prepared and available for the Surveyors.

5.3.2(f) The attending ABS Surveyors, at the engine builder/licensee/subcontractors, will issue product certificates as necessary for components manufactured upon satisfactory inspections and tests.

5.3.2(g) The engine builder/licensee assembles the engine, tests the engine with an ABS Surveyor present. An engine certificate is issued by the Surveyor upon satisfactory completion of assembly and tests.

5.3.2(h) A representative document flow process for obtaining an engine certificate is shown in 4-2-1A1A2/Figure 2.

** *Note:* Process of engine certificate for each diesel engines are equivalent to the ABS Type Approval Certificate including product design assessment and manufacture assessment under ABS Type Approval Program.

5.5 Approval of Diesel Engine Components

Components of engine designer's design which are covered by the type approval certificate of the relevant engine type are regarded as approved whether manufactured by the engine manufacturer or sub-supplied. For components of subcontractor's design, necessary approvals are to be obtained by the relevant suppliers (e.g., exhaust gas turbochargers, charge air coolers, etc.).

5.7 Submission Format of Documentation

ABS determines the documentation format: electronic or paper. If documentation is to be submitted in paper format, the number of copies is determined by ABS.

7 Type Approval Process

The type approval process consists of the steps in 4-2-1A1/7.1 to 4-2-1A1/7.7. The document flow for this process is shown in 4-2-1A1A2/Figure 1.

The documentation, as far as applicable to the type of engine, to be submitted by the engine designer/licensor to ABS is listed in 4-2-1A1/Table 1 and 4-2-1A1/3.

7.1 Documents for Information Table 1

4-2-1A1/Table 1 lists basic descriptive information to provide ABS an overview of the engine's design, engine characteristics and performance. Additionally, there are requirements related to auxiliary systems for the engine's design including installation arrangements, list of capacities, technical specifications and requirements, along with information needed for maintenance and operation of the engine.

7.3 Documents for Approval or Recalculation Table 2

4-2-1A1/Table 2 lists the documents and drawings, which are to be approved by ABS.

7.5 Design Approval/Appraisal (DA)

DA's are valid as long as no substantial modifications have been implemented. Where substantial modifications have been made the validity of the DA's may be renewed based on evidence that the design is in conformance with all current Rules and statutory regulations (e.g., SOLAS, MARPOL). See also 4-2-1A1/7.11.

7.7 Type Approval Test

A type approval test is to be carried out in accordance with 4-2-1/13.7 or 4-2-1/13.11 and is to be witnessed by ABS.

The manufacturing facility of the engine presented for the type approval test is to be assessed in accordance with 4-2-1/13.6 and 4-2-1/Tables 1 and 2 (applicable section).

7.9 Type Approval Certificate

After the requirements in 4-2-1A1/7.1 through 4-2-1A1/7.7 have been satisfactorily completed ABS issues a type approval certificate (TAC).

7.11 Design Modifications

After ABS has approved the engine type for the first time, only those documents as listed in the tables, which have undergone substantive changes, will have to be resubmitted for consideration by ABS.

7.13 Type Approval Certificate Renewals

A renewal of type approval certificates will be granted upon:

7.13.1 Submission of Information in either 4-2-1A1/7.13.1(a) or 4-2-1A1/7.13.1(b)

7.13.1(a) The submission of modified documents or new documents with substantial modifications replacing former documents compared to the previous submission(s) for DA.

7.13.1(b) A declaration that no substantial modifications have been applied since the last DA issued.

7.15 Validity of Type Approval Certificate

ABS reserves the right to limit the duration of validity of the type approval certificate. The type approval certificate will be invalid if there are substantial modifications in the design, in the manufacturing or control processes or in the characteristics of the materials unless approved in advance by ABS.

7.17 Document Review and Approval

7.17.1

The assignment of documents to 4-2-1A1/Table 1 for information does not preclude possible comments by the individual ABS.

7.17.2

Where considered necessary, ABS may request further documents to be submitted. This may include details or evidence of existing type approval or proposals for a type testing program in accordance with 4-2-1/13.7 or 4-2-1/13.11.

9 Certification Process

The certification process consists of the steps in 4-2-1A1/9.1 to 4-2-1A1/9.9. This process is illustrated in 4-2-1A1A2/Figure 2 showing the document flows between the:

- Engine designer/licensor,
- Engine builder/licensee,
- Component manufacturers,
- ABS approval center, and
- ABS site offices.

For those cases when a licensor-licensee agreement does not apply, an “engine designer” shall be understood as the entity that has the design rights for the engine type or is delegated by the entity having the design rights to modify the design.

The documents listed in 4-2-1A1/Table 3 may be submitted by:

- The engine designer (licensor),
- The manufacturer/licensee.

9.1 Document Development for Production

Prior to the start of the engine certification process, a design approval is to be obtained per 4-2-1A1/7.1 through 4-2-1A1/7.5 for each type of engine. Each type of engine is to be provided with a type approval certificate obtained by the engine designer/licensor prior to the engine builder/licensee beginning production manufacturing. For the first engine of a type, the type approval process and the certification process may be performed simultaneously.

The engine designer/licensor reviews the documents listed in 4-2-1A1/Table 1 and 4-2-1A1/Table 2 for the application and develops, if necessary, application specific documentation for the use of the engine builder/licensee in developing engine specific production documents.

If substantive changes have been made, the affected documents are to be resubmitted to ABS as per 4-2-1A1/7.11.

9.3 Documents to be Submitted for Inspection and Testing

4-2-1A1/Table 3 lists the production documents, which are to be submitted by the engine builder/licensee to ABS following acceptance by the engine designer/licensor. The Surveyor uses the information for inspection purposes during manufacture and testing of the engine and its components. See 4-2-1A1/5.3.2(c) through 4-2-1A1/5.3.2(f).

9.5 Alternative Execution

If there are differences in the technical content on the licensee's production drawings/documents compared to the corresponding licensor's drawings, the licensee must provide to ABS Engineering a "Confirmation of the licensor's acceptance of licensee's modifications" approved by the licensor and signed by licensee and licensor. Modifications applied by the licensee are to be provided with appropriate quality requirements. See 4-2-1A1/Annex 5 for a sample format.

9.7 Manufacturer Approval

ABS assesses conformity of production with ABS's requirements for production facilities comprising manufacturing facilities and processes, machining tools, quality assurance, testing facilities, etc. See 4-2-1/13.6 and 4-2-1/Tables 1 and 2 (applicable section). Satisfactory conformance results in the issue of a class approval document.

9.9 Document Availability

In addition to the documents listed in 4-2-1A1/Table 3, the engine builder/licensee is to be able to provide to the Surveyor performing the inspection upon request the relevant detail drawings, production quality control specifications and acceptance criteria. These documents are for supplemental purposes to the survey only.

9.11 Engine Assembly and Testing

Each engine assembly and testing procedure required according to relevant Section 4-2-1 requirements are to be witnessed by the ABS attending Surveyor unless an Alternative Certification Scheme meeting the requirements of 4-2-1/13.11.2 (applicable sections) is agreed between manufacturer and the IACS Society.

TABLE 1
Documentation to be Submitted for Information, as Applicable

No.	Item
1	Engine particulars (e.g., Data sheet with general engine information (see 4-2-1A1/Annex 3), Project Guide, Marine Installation Manual)
2	Engine cross section
3	Engine longitudinal section
4	Bedplate and crankcase of cast design
5	Thrust bearing assembly ⁽¹⁾
6	Frame/framebox/gearbox of cast design ⁽²⁾
7	Tie rod
8	Connecting rod
9	Connecting rod, assembly ⁽³⁾
10	Crosshead, assembly ⁽³⁾
11	Piston rod, assembly ⁽³⁾
12	Piston, assembly ⁽³⁾
13	Cylinder jacket/ block of cast design ⁽²⁾
14	Cylinder cover, assembly ⁽³⁾
15	Cylinder liner
16	Counterweights (if not integral with crankshaft), including fastening
17	Camshaft drive, assembly ⁽³⁾
18	Flywheel
19	Fuel oil injection pump
20	Shielding and insulation of exhaust pipes and other parts of high temperature which may be impinged as a result of a fuel system failure, assembly
For electronically controlled engines, construction and arrangement of:	
21	Control valves
22	High-pressure pumps
23	Drive for high pressure pumps
24	Operation and service manuals ⁽⁴⁾
25	FMEA (for engine control system) ⁽⁵⁾
26	Production specifications for castings and welding (sequence)
27	Evidence of quality control system for engine design and in service maintenance
28	Quality requirements for engine production
29	Type approval certification for environmental tests, control components ⁽⁶⁾

Notes:

- 1 If integral with engine and not integrated in the bedplate.
- 2 Only for one cylinder or one cylinder configuration.
- 3 Including identification (e.g., drawing number) of components.
- 4 Operation and service manuals are to contain maintenance requirements (servicing and repair) including details of any special tools and gauges that are to be used with their fitting/settings together with any test requirements on completion of maintenance.
- 5 Where engines rely on hydraulic, pneumatic or electronic control of fuel injection and/or valves, a failure mode and effects analysis (FMEA) is to be submitted to demonstrate that failure of the control system will not result in the operation of the engine being degraded beyond acceptable performance criteria for the engine. The FMEA reports required will not be explicitly approved by ABS.
- 6 Tests are to demonstrate the ability of the control, protection and safety equipment to function as intended under the specified testing conditions per UR E10.

TABLE 2
Documentation to be Submitted for Approval, as Applicable

No.	Item
1	Bedplate and crankcase of welded design, with welding details and welding instructions ^(1,2)
2	Thrust bearing bedplate of welded design, with welding details and welding instructions ⁽¹⁾
3	Bedplate/oil sump welding drawings ¹
4	Frame/framebox/gearbox of welded design, with welding details and instructions ^(1,2)
5	Engine frames, welding drawings ^(1,2)
6	Crankshaft, details, each cylinder No.
7	Crankshaft, assembly, each cylinder No.
8	Crankshaft calculations (for each cylinder configuration) according to the attached data sheet and UR M53
9	Thrust shaft or intermediate shaft (if integral with engine)
10	Shaft coupling bolts
11	Material specifications of main parts with information on non-destructive material tests and pressure tests ⁽³⁾
	Schematic layout or other equivalent documents on the engine of:
12	Starting air system
13	Fuel oil system
14	Lubricating oil system
15	Cooling water system
16	Hydraulic system
17	Hydraulic system (for valve lift)
18	Engine control and safety system
19	Shielding of high pressure fuel pipes, assembly ⁽⁴⁾
20	Construction of accumulators (common rail) (for electronically controlled engine)
21	Construction of common accumulators (common rail) (for electronically controlled engine)
22	Arrangement and details of the crankcase explosion relief valve (see 4-2-1/7.1) ⁽⁵⁾
23	Calculation results for crankcase explosion relief valves (see Appendix 4-2-1A5)
24	Details of the type test program and the type test report ⁽⁷⁾
25	High pressure parts for fuel oil injection system ⁽⁶⁾
26	Oil mist detection and/or alternative alarm arrangements (see 4-2-1/7.2)
27	Details of mechanical joints of piping systems (see 4-6-2/5.9)
28	Documentation verifying compliance with inclination limits (see 4-1-1/Table 7)
29	Documents as required in Section 4-9-3, as applicable

Notes:

- 1 For approval of materials and weld procedure specifications. The weld procedure specification is to include details of pre and post weld heat treatment, weld consumables and fit-up conditions.
- 2 For each cylinder for which dimensions and details differ.
- 3 For comparison with Society requirements for material, NDT and pressure testing as applicable.
- 4 All engines.
- 5 Only for engines of a cylinder diameter of 200 mm or more or a crankcase volume of 0.6 m³ or more.
- 6 The documentation to contain specifications for pressures, pipe dimensions and materials.
- 7 The type test report may be submitted shortly after the conclusion of the type test.

TABLE 3
Documentation for the Inspection of Components and Systems

- Special consideration will be given to engines of identical design and application
- For engine applications refer to 4-2-1/13.6 and 4-2-1/Tables 1 and 2

No.	Item
1	Engine particulars as per data sheet in 4-2-1A1/Annex 3
2	Material specifications of main parts with information on non-destructive material tests and pressure tests ⁽¹⁾
3	Bedplate and crankcase of welded design, with welding details and welding instructions ⁽²⁾
4	Thrust bearing bedplate of welded design, with welding details and welding instructions ⁽²⁾
5	Frame/framebox/gearbox of welded design, with welding details and instructions ⁽²⁾
6	Crankshaft, assembly and details
7	Thrust shaft or intermediate shaft (if integral with engine)
8	Shaft coupling bolts
9	Bolts and studs for main bearings
10	Bolts and studs for cylinder heads and exhaust valve (two stroke design)
11	Bolts and studs for connecting rods
12	Tie rods
	Schematic layout or other equivalent documents on the engine of: ⁽³⁾
13	Starting air system
14	Fuel oil system
15	Lubricating oil system
16	Cooling water system
17	Hydraulic system
18	Hydraulic system (for valve lift)
19	Engine control and safety system
20	Shielding of high pressure fuel pipes, assembly ⁽⁴⁾
21	Construction of accumulators for hydraulic oil and fuel oil
22	High pressure parts for fuel oil injection system ⁽⁵⁾
23	Arrangement and details of the crankcase explosion relief valve (see 4-2-1/7.1) ⁽⁶⁾
24	Oil mist detection and/or alternative alarm arrangements (see 4-2-1/7.2)
25	Cylinder head
26	Cylinder block, engine block
27	Cylinder liner
28	Counterweights (if not integral with crankshaft), including fastening
29	Connecting rod with cap
30	Crosshead
31	Piston rod
32	Piston, assembly ⁽⁷⁾
33	Piston head
34	Camshaft drive, assembly ⁽⁷⁾
35	Flywheel
36	Arrangement of foundation (for main engines only)
37	Fuel oil injection pump
38	Shielding and insulation of exhaust pipes and other parts of high temperature which may be impinged as a result of a fuel system failure, assembly
39	Construction and arrangement of dampers

TABLE 3 (continued)
Documentation for the Inspection of Components and Systems

No.	Item
	For electronically controlled engines, assembly drawings or arrangements of:
40	Control valves
41	High-pressure pumps
42	Drive for high pressure pumps
43	Valve bodies, if applicable
44	Operation and service manuals ⁽⁸⁾
45	Test program resulting from FMEA (for engine control system) ⁽⁹⁾
46	Production specifications for castings and welding (sequence)
47	Type approval certification for environmental tests, control components ⁽¹⁰⁾
48	Quality requirements for engine production

Notes:

- 1 For comparison with Society requirements for material, NDT and pressure testing as applicable.
- 2 For approval of materials and weld procedure specifications. The weld procedure specification is to include details of pre and post weld heat treatment, weld consumables and fit-up conditions.
- 3 Details of the system so far as supplied by the engine manufacturer such as: main dimensions, operating media and maximum working pressures.
- 4 All engines.
- 5 The documentation to contain specifications for pressures, pipe dimensions and materials.
- 6 Only for engines of a cylinder diameter of 200 mm or more or a crankcase volume of 0.6 m³ or more.
- 7 Including identification (e.g., drawing number) of components.
- 8 Operation and service manuals are to contain maintenance requirements (servicing and repair) including details of any special tools and gauges that are to be used with their fitting/settings together with any test requirements on completion of maintenance.
- 9 Required for engines that rely on hydraulic, pneumatic or electronic control of fuel injection and/or valves.
- 10 Documents modified for a specific application are to be submitted to ABS for information or approval, as applicable. See 4-2-1A1/5.3.2(b), 4-2-1A1/Annex 4 and 4-2-1A1/Annex 5.

ANNEX 1 – Glossary

Term	Definition
Acceptance criteria	A set of values or criteria which a design, product, service or process is required to conform with, in order to be considered in compliance
Accepted	Status of a design, product, service or process, which has been found to conform to specific acceptance criteria
Alternative Certification Scheme (ACS)	A system, by which a society evaluates a manufacturer's quality assurance and quality control arrangements for compliance with Rule requirements, then authorizes a manufacturer to undertake and witness testing normally required to be done in the presence of a Surveyor. The Alternative Certification Scheme as presently administrated by the IACS Member Societies.
Appraisal	Evaluation by a competent body
Approval	The granting of permission for a design, product, service or process to be used for a stated purpose under specific conditions based upon a satisfactory appraisal

<i>Term</i>	<i>Definition</i>
Assembly	Equipment or a system made up of components or parts
Assess	Determine the degree of conformity of a design, product, service, process, system or organization with identified specifications, Rules, standards or other normative documents
Audit	Planned systematic and independent examination to determine whether the activities are documented, the documented activities are implemented, and the results meet the stated objectives
Auditor	Individual who has the qualifications and experience to perform audits
Certificate	A formal document attesting to the compliance of a design, product, service or process with acceptance criteria
Certification	A procedure whereby a design, product, service or process is approved in accordance with acceptance criteria
Class	Short for ABS
Class approval	Approved by ABS
Classification	Specific type of certification, which relates to the ABS Rules
Competent body	Organization recognized as having appropriate knowledge and expertise in a specific area
Component	Part, member of equipment or system
Conformity	Where a design, product, process or service demonstrates compliance with its specific requirements
Contract	Agreement between two or more parties relating to the scope of service
Contractor	see “Supplier”
Customer	Party who purchases or receives goods or services from another
Design	All relevant plans, documents, calculations described in the performance, installation and manufacturing of a product
Design analysis	Investigative methodology selectively used to assess the design
Design appraisal	Evaluation of all relevant plans, calculations and documents related to the design
Design review	Part of the appraisal process to evaluate specific aspects of the design
Drawings approval/ plan approval	Part of the design approval process which relates to the evaluation of drawings and plans
Equipment	Part of a system assembled from components
Equivalent	An acceptable, no less effective alternative to specified criteria
Evaluation	Systematic examination of the extent to which a design, product, service or process satisfies specific criteria
Examination	Assessment by a competent person to determine compliance with requirements
Inspection	Examination of a design, product service or process by an Inspector

<i>Term</i>	<i>Definition</i>
Inspection plan	List of tasks of inspection to be performed by the Inspector
Installation	The assembling and final placement of components, equipment and subsystems to permit operation of the system
Manufacturer	Party responsible for the manufacturing and quality of the product
Manufacturing process	Systematic series of actions directed towards manufacturing a product
Manufacturing process approval	Approval of the manufacturing process adopted by the manufacturer during production of a specific product
Material	Goods supplied by one manufacturer to another manufacturer that will require further forming or manufacturing before becoming a new product
Modification	A limited change that does not affect the current approval
Modification notice	Information about a design modification with new modification index or new drawing number replacing the earlier drawing
Performance test	Technical operation where a specific performance characteristic is determined
Producer	See “Manufacturer”
Product	Result of the manufacturing process
Prototype test	Investigations on the first or one of the first new engines with regard to optimization, fine tuning of engine parameters and verification of the expected running behavior
Quality assurance	All the planned and systematic activities implemented within the quality system, and demonstrated as needed to provide adequate confidence that an entity will fulfil requirements for quality. Refer to ISO 9000 series
Regulation	Rule or order issued by an executive authority or regulatory agency of a government and having the force of law
Repair	Restore to original or near original condition from the results of wear and tear or damages for a product or system in service
Requirement	Specified characteristics used for evaluation purposes
Information	Additional technical data or details supplementing the drawings requiring approval
Revision	Means to record changes in one or more particulars of design drawings or specifications
Specification	Technical data or particulars which are used to establish the suitability of materials, products, components or systems for their intended use
Substantive modifications or major modifications or major changes	Design modifications, which lead to alterations in the stress levels, operational behavior, fatigue life or an effect on other components or characteristics of importance such as emissions
Subsupplier/subcontractor	One who contracts to supply material to another supplier
Supplier	One who contracts to furnish materials or design, products, service or components to a customer or user

<i>Term</i>	<i>Definition</i>
Test	A technical operation that consists of the determination of one or more characteristics or performance of a given product, material, equipment, organism, physical phenomenon, process or service according to a specified procedure. A technical operation to determine if one or more characteristic(s) or performance of a product, process or service satisfies specific requirements
Traceability	Ability to follow back through the design and manufacturing process to the origin
Type approval	The establishment of the acceptability of a product through the systematic: <ol style="list-style-type: none"> 1. Evaluation of a design to determine conformance with specifications 2. Witnessing manufacture and testing of a type of product to determine compliance with the specification 3. Evaluation of the manufacturing arrangements to confirm that the product can be consistently produced in accordance with the specification
Type approval test	Last step of the type approval procedure. Test program in accordance with 4-2-1/7
Witness	Individual physically present at a test and being able to record and give evidence about its outcome

ANNEX 2 – Representative Document Flow Diagrams

The document flow diagrams in this Annex are provided as an aid to all parties involved in the engine certification process as to their roles and responsibilities. Variations in the document flow may vary in response to unique issues with regard to various factors related to location, availability of components and surveys. In any case, the text in Appendix 4-2-1A1 takes precedence over 4-2-1A1/Annex 2 flow diagrams.

FIGURE 1
Type Approval Document Flow

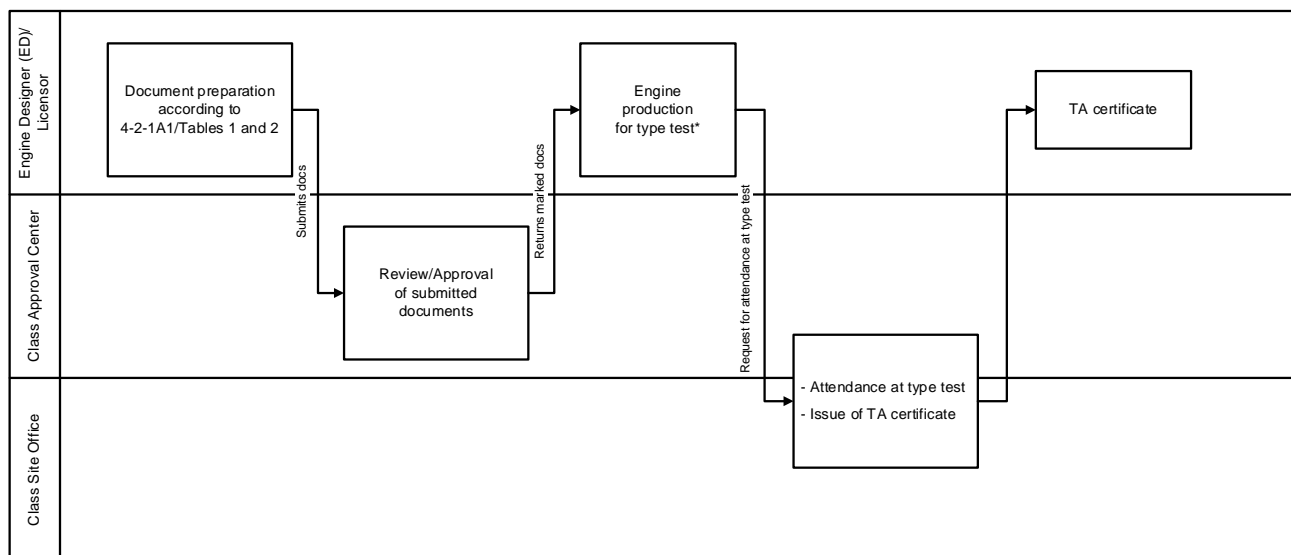
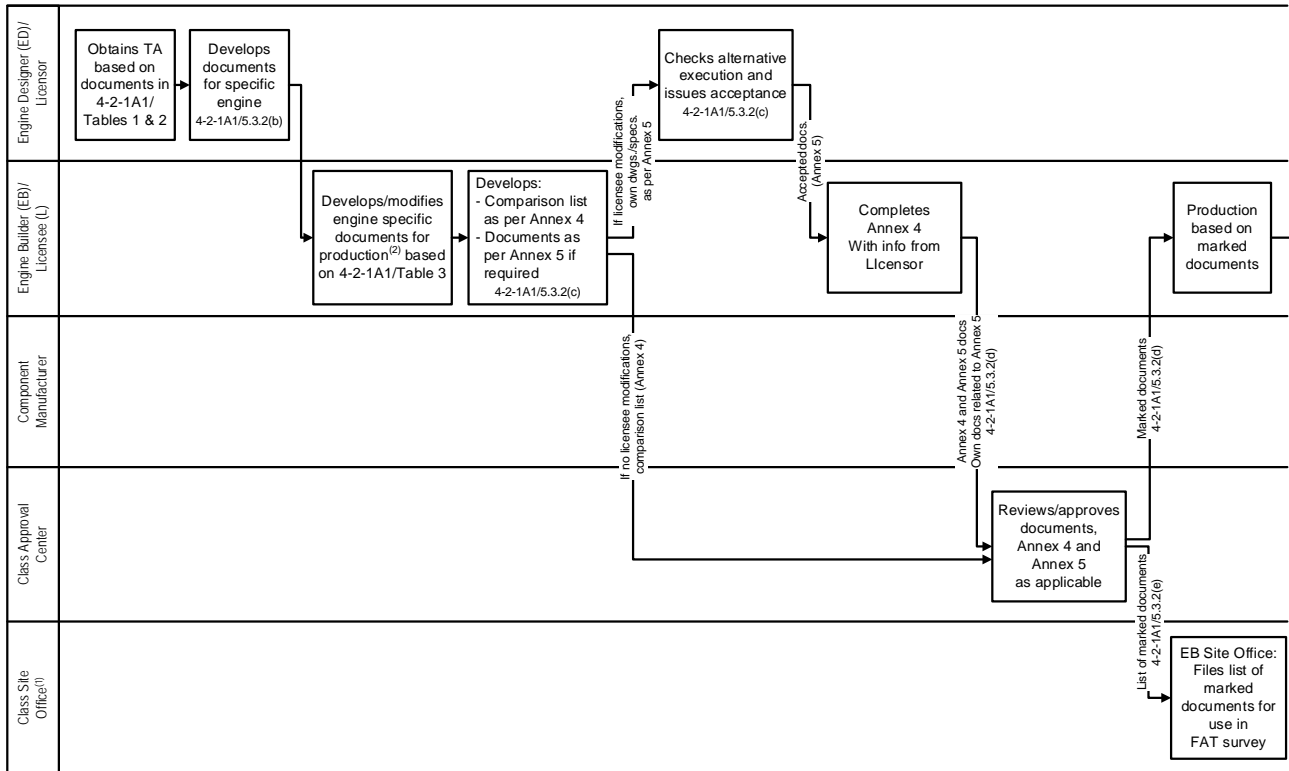
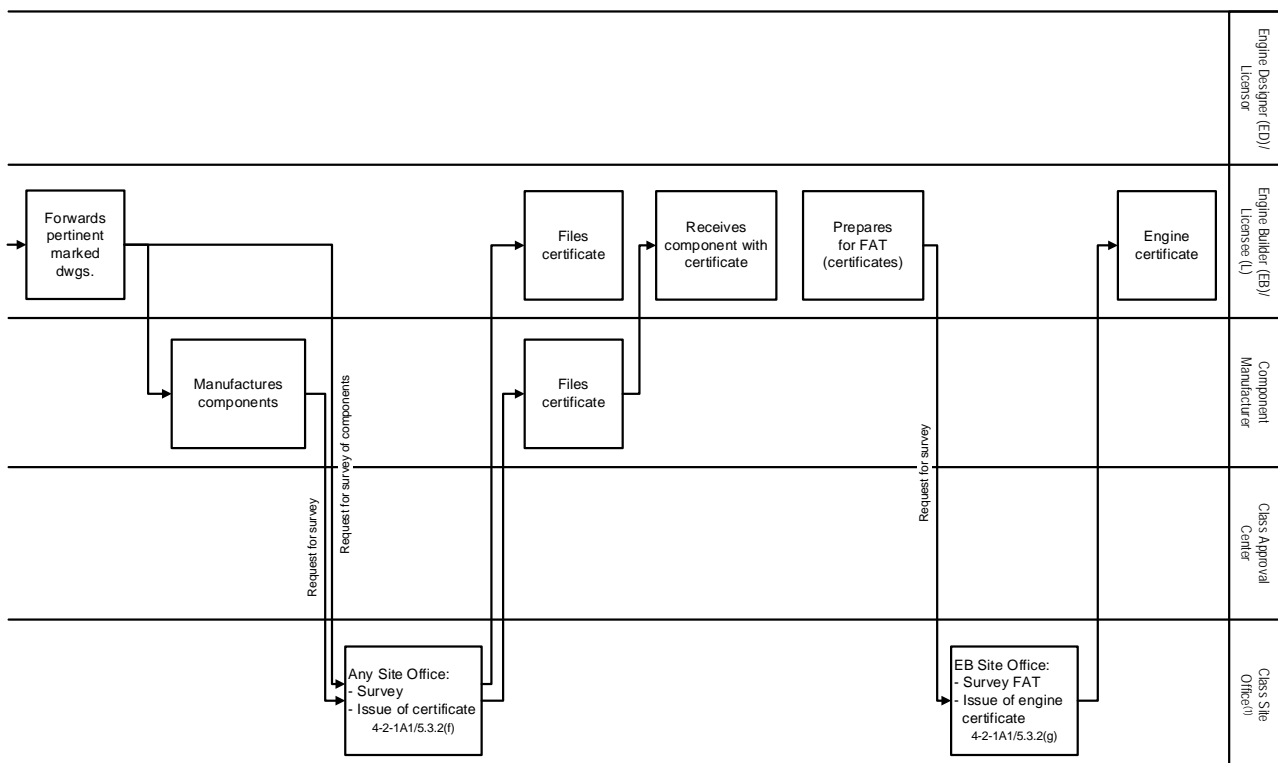

FIGURE 2
Engine Certificate Document Flow



1 Class Site office with responsibility for engine builder and/or component manufacturers in different locations
 2 For alternative execution, see 4-2-1A1/9.5

FIGURE 2 (continued)
Engine Certificate Document Flow



ANNEX 3 – Internal Combustion Engine Approval Application Form and Data Sheet

Class Application number (if applicable):

Engine Manufacturer's Application Identification Number:

General Data			
Engine Designer: Contact Person: Address:	Engine Manufacturer(s), Licensee(s) and/or Manufacturing Sites' Name Country		
1. Document purpose <i>(select options from either 1a or 1b)</i>			
1a. Type Approval Application			
Service Requested <input type="checkbox"/> New Type Approval <input type="checkbox"/> Renew Type Approval <input type="checkbox"/> Amend Type Approval <input type="checkbox"/> Design Evaluation <input type="checkbox"/> Update TA Supplement <input type="checkbox"/> Other	<i>Required activities†</i> <ul style="list-style-type: none"> • DA, TT, CoP • CoP, if design change then amended or new certificate process to be followed • DA & CoP, Further TT if previously approved engine has been substantively modified (as required by UR M71) • DA, TT, applicable where designer does not have production facilities, Type Approval to be granted to specific production facility once associated CoP has been completed • Update to Supplement, only for minor changes not affecting the Type Approval Certificate • e.g. National/Statutory Administration requirements i.e. MSC.81(70) for emergency engines 		
For TA Cert amendments or Supplement updates, details of what is to be changed:			
For 'Other', Details of the requirements to be considered:			
1b. Addendum for Individual Engine FAT and Certification			
<input type="checkbox"/> Individual engine requiring FAT and Certification, only where the performance data for the engine being certified differs from the details provided on the original Type Approval Application. Only section 3b requires completion. Where changes to other sections are necessary, a new Type Approval Application may be required.			
Reference number of <i>Internal Combustion Engine Approval Application Form</i> previously submitted and reference number of the Type Approval Certificate.	<i>(Copy of original application form to be attached to this document)</i>		
2. Existing documentation			
Previous Class Type Approval Certificate No. or related Design Approval No. <i>(if applicable)</i>			
Formerly issued documentation for engine <i>(E.g. previous type test reports, in-service experience justification reports, etc.)</i>	Issuing Body:	Document Type:	Document No.:
Existing Certification <i>(E.g. Manufacturer's quality certification ISO 9001 etc.)</i>	Issuing Body:	Document Type:	Document No.:
3. Design <i>(mark all that apply)</i>			
3a. Engine Particulars:			
Engine Type	Number of delivered marine engines‡:		
Manufactured Since‡:			
Application	<input type="checkbox"/> Direct drive Propulsion <input type="checkbox"/> Auxiliary <input type="checkbox"/> Emergency <input type="checkbox"/> Single engine / <input type="checkbox"/> Multi-engine installation <input type="checkbox"/> Aux. Services / <input type="checkbox"/> Electric Propulsion		
Mechanical Design	<input type="checkbox"/> 2-stroke <input type="checkbox"/> 4-stroke <input type="checkbox"/> In-line <input type="checkbox"/> Vee (V-angle °) <input type="checkbox"/> Other () <input type="checkbox"/> Cross-head <input type="checkbox"/> Trunk-piston <input type="checkbox"/> Reversible <input type="checkbox"/> Non-reversible Cylinder bore(mm) Length of piston stroke (mm)		
Supercharging	<input type="checkbox"/> Without supercharging <input type="checkbox"/> With supercharging <input type="checkbox"/> Without charge air cooling <input type="checkbox"/> With charge air cooling <input type="checkbox"/> Constant-pressure charging system <input type="checkbox"/> Pulsating pressure charging system		
Valve operation	<input type="checkbox"/> Cam control <input type="checkbox"/> Electronic control		
Fuel Injection	<input type="checkbox"/> Direct injection <input type="checkbox"/> Indirect injection <input type="checkbox"/> Cam controlled injection <input type="checkbox"/> Electronically controlled injection		

Fuel Types [§] (Classification according to ISO 8216)	<input type="checkbox"/> Marine residual fuel <input type="checkbox"/> Marine distillate fuel <input type="checkbox"/> Marine distillate fuel <input type="checkbox"/> Low flashpoint liquid fuel (specify fuel type) <input type="checkbox"/> Gas (specify gas type) <input type="checkbox"/> Other (specify) <input type="checkbox"/> Dual Fuel (specify combinations of fuels to be used simultaneously)	cSt (Max. kinematic viscosity at 50°C) DMA, DMB, DMC DMX
3b. Performance Data <i>(Related to: Barometric pressure 1,000 mbar; Air temperature 45°C; Relative humidity 60%; Seawater temperature 32°C)</i>		
Model reference No. (if applicable)		
Max. continuous rating	kW/cyl	
Rated speed	1/min	
Mean indicated pressure	MPa	
Mean effective pressure	MPa	
Max. firing pressure	MPa	
Charge air pressure	MPa	
Compression ratio	-	
Mean piston speed	m/s	
3c. Crankshaft		
Design	<input type="checkbox"/> Solid <input type="checkbox"/> Semi-built <input type="checkbox"/> Built	
Method of Manufacture	<input type="checkbox"/> Cast <input type="checkbox"/> Forged <input type="checkbox"/> Slab forged <input type="checkbox"/> Approved die forged <input type="checkbox"/> Continuous grain flow process	
State approved forge/works name:		
Is the crankshaft hardened by an approved process which includes the fillet radii of crankpins and journals? <input type="checkbox"/> Yes <input type="checkbox"/> No		
If yes, state process:		
Crankshaft material specification:		
U.T.S. (N/mm ²)	Yield strength (N/mm ²)	
Hardness value (Brinell/Vickers)	Elongation (%)	
Dimensional Data		
If shrunk on webs, state shrinkage allowance (mm)	Yield strength of crankweb material (N/mm ²)	
Centre of gravity of connecting rod from large end centre (mm)	Radius of gyration of connecting rod (mm)	
Mass of each crankweb (kg)	Centre of gravity of web from journal axis (mm)	
Mass of each counterweight (kg)	Centre of gravity of each counterweight from journal axis (mm)	
Axial length of main bearing (mm)	Main bearing working clearance (mm)	
Mass of flywheel at driving end (kg)	Mass of flywheel at opposite end (kg)	
Nominal alternating torsional stress in crankpin (N/mm ²)	Nominal alternating torsional stress in crank journal (N/mm ²)	
Length between centres (Total length)(mm)		
3d. Firing order		
State numbering system of cylinders from left to right as per above diagrams (as applicable)		
Number of cylinders	Clockwise firing order	Counter-clockwise firing order

4. Engine Ancillary Systems					
4a. Turbochargers		<input type="checkbox"/> Fitted		<input type="checkbox"/> Not Fitted	
Turbocharger oil supply by:		<input type="checkbox"/> Engine lub. oil system		<input type="checkbox"/> TC internal lub. oil system	
No. of cylinders	No. of aux blowers	No. of charge air coolers	No. of TC	TC manufacturer & type	TC type approval certificate No.
				/	
				/	
				/	
				/	
				/	
				/	
4b. Speed governor					
Engine application (Main/Aux/Emergency)		Manufacturer / type		Mode of operation	Type approval cert. No. (if electric / electronic gov.)
		/			
		/			
		/			
4c. Overspeed protection					
Independent overspeed protection available		<input type="checkbox"/> Yes <input type="checkbox"/> No		Mode of operation:	
Manufacturer / type, if electronic:		/		Type approval certificate No.	
4d. Electronic systems					
Engine control and management system					
<i>Note: use Remarks section to identify when a different engine control system will be used for Type Test</i>					
Hardware: Manufacturer & Model:		/		Type approval certificate No.	
Software: Name & Version:		/		Software conformity certificate No.	
Additional electronic system 1:		System function:			
Manufacturer & type: /		Type approval certificate No.			
Additional electronic system 2:		System function:			
Manufacturer & type: /		Type approval certificate No.			
Additional electronic system 3:		System function:			
Manufacturer & type: /		Type approval certificate No.			
4e. Starting System					
Type:					
4f. Safety devices/functions					
A flame arrestor or a bursting disk is installed in the starting air system:		before each starting valve <input type="checkbox"/> Yes <input type="checkbox"/> No		in the starting air manifold <input type="checkbox"/> Yes <input type="checkbox"/> No	
Crankcase relief valves available		<input type="checkbox"/> Yes <input type="checkbox"/> No		Manufacturer / type: /	
Type approval certificate No.					
No. of cyl.	Total crankcase gross volume incl. attachments (m ³)	Type & size (mm) of relief valve	Relief area per relief valve (mm ²)	No. of relief valves	
		/			
		/			
		/			
		/			
Method used for detection of potentially explosive crankcase condition:					
<input type="checkbox"/> Oil mist detector: Manufacturer / type:		/ Type approval certificate No.			
<input type="checkbox"/> Alternative method: (mark all that apply)		<input type="checkbox"/> crankcase pressure monitoring		<input type="checkbox"/> bearing temperature monitoring <input type="checkbox"/> other:	
		<input type="checkbox"/> oil splash temperature monitoring		<input type="checkbox"/> recirculation arrangements	
Cylinder overpressure warning device available		<input type="checkbox"/> Yes <input type="checkbox"/> No			
Type:		Opening pressure (bar):			
4g. Attached ancillary equipment (Mark all that apply)					
Engine driven pumps:					
<input type="checkbox"/> Main lubricating oil pump		<input type="checkbox"/> Sea cooling water pump		<input type="checkbox"/> LT-fresh cooling water pump	
<input type="checkbox"/> HT-fresh cooling water pump		<input type="checkbox"/> Fuel oil booster pump		<input type="checkbox"/> Hydraulic oil pump <input type="checkbox"/> Other ()	
Engine attached motor driven pumps:					
<input type="checkbox"/> Lubricating oil pump		<input type="checkbox"/> Cooling fresh water pump		<input type="checkbox"/> Fuel oil booster pump	
<input type="checkbox"/> Hydraulic oil pump		<input type="checkbox"/> Other ()			

Engine attached cooler or heater:				
<input type="checkbox"/> Lubricating oil cooler	<input type="checkbox"/> Lubricating oil heater	<input type="checkbox"/> Fuel oil valve cooler		
<input type="checkbox"/> Hydraulic oil cooler	<input type="checkbox"/> Cooling fresh water cooler			
Engine attached filter:				
Lubricating oil filter	<input type="checkbox"/> Single	<input type="checkbox"/> Duplex	<input type="checkbox"/> Automatic	
Fuel oil filter	<input type="checkbox"/> Single	<input type="checkbox"/> Duplex	<input type="checkbox"/> Automatic	
5. Inclination limits <i>(engine operation is safeguarded under the following limits)</i>		Athwartships		Fore-and-aft
		Static	Dynamic	Static Dynamic
Main & Auxiliary machinery		<input type="checkbox"/> 15.0°	<input type="checkbox"/> 22.5°	<input type="checkbox"/> 5.0° <input type="checkbox"/> 7.5°
Emergency machinery		<input type="checkbox"/> 22.5°	<input type="checkbox"/> 22.5°	<input type="checkbox"/> 10.0° <input type="checkbox"/> 10.0°
Emergency machinery on ships for the carriage of liquefied gas and liquid chemicals		<input type="checkbox"/> 30.0°	<input type="checkbox"/> 30.0°	
6. Main engine emergency operation				
At failure of one auxiliary blower, engine can be started and operated at partial load			<input type="checkbox"/> Yes	<input type="checkbox"/> No
At failure of one turbocharger, engine operation can be continued			<input type="checkbox"/> Yes	<input type="checkbox"/> No
7. References: <i>Additional Information Attached to Application</i>				
Document Name/Number		Summary of information contained in document		
8. Further Remarks:				

* All parties that affect the final complete engine (e.g. manufacture, modify, adjust) are to be listed. All sites where such work is carried out may be required to complete CoP assessment.

† DA = Design Appraisal, TT = Type Test, CoP = Assessment of Conformity of Production. See 1-1/A3, 4-2-1/A1 and 4-2-1/13.7.

‡ Only in case of TA Extension.

§ See 'Definitions' at the end of this application form for more information.

Completed By: _____ Signature: _____

Company: _____

Job Title: _____ Stamp: _____

Date: _____

Definitions:

Complete Engine includes the control system and all ancillary systems and equipment referred to in the Rules that are used for safe operation of the engine and for which there are rule requirements, this includes systems allowing the use of different fuel types. The exact list of components/items that will need to be tested in together with the bare engine will depend on the specific design of the engine, its control system and the fuel(s) used but may include, but are not limited to, the following:

- (a) Turbocharger(s)
- (b) Crankcase explosion relief devices
- (c) Oil mist detection and alarm devices
- (d) Piping
- (e) Electronic monitoring and control system(s) – software and hardware
- (f) Fuel management system (where dual fuel arrangements are fitted)
- (g) Engine driven pumps
- (h) Engine mounted filters

Fuel Types: All fuels that the engine is designed to operate with are to be identified on the application form as this may have impact on the requirements that are applicable for Design Appraisal and the scope of the tests required for Type Testing. Where the engine is to operate in a Dual Fuel mode, the combinations of fuel types are to be detailed. E.g. Natural Gas + DMA, Natural Gas + Marine Residual Fuel, the specific details of each fuel are to be provided as indicated in the relevant rows of the Fuel Types part of section 3a of this form.

ANNEX 5 – Sample Template for Confirmation of the Licensor’s
 Acceptance of Licensee’s Modifications

Engine Licensee Proposed Alternative to Licensor’s Design			
Licensee information			
Licensee:		Ref No.:	
Description:		Info No.:	
Engine type:		Main Section:	
Engine No.:		Plant Id.:	
Design Spec: <input type="checkbox"/> General <input type="checkbox"/> Specific Nos:			
<i>Licensor design:</i>	<small>State relevant part or drawing numbers. Insert drawing clips or pictures. Add any relevant information</small>		<i>Licensee Proposed Alternative</i>
		For example:	
		<ul style="list-style-type: none"> • Differences in geometry • Differences in the functionality • Material • Hardness • Surface condition • Alternative standard • Licensee production information introduced on the drawing • Weldings or castings • etc. 	
Reason:	<input type="checkbox"/> Licensee’s production <input type="checkbox"/> Sub-supplier’s production <input type="checkbox"/> Cost down <input type="checkbox"/> Tools	Interchangeability w. licensor design <input type="checkbox"/> Yes <input type="checkbox"/> No	Non-conformity Report Research, Assessment, Evaluation <input type="checkbox"/> NCR <input type="checkbox"/> RAE
			Certified by licensee: Initials: Date:
Licensor comments			
LoAE:	<input type="checkbox"/> Accepted as alternative execution <small>(Licensor undertakes responsibility)</small> <input type="checkbox"/> No objection <input type="checkbox"/> Not acceptable <small>(Licensee undertakes responsibility)</small>	NCR:	<input type="checkbox"/> Approved <input type="checkbox"/> Conditionally approved <input type="checkbox"/> Rejected
			Certified by licensor: Initials: Date:
Licensor ref.:			Date:
Licensee ref.:			Date:

PART

4

CHAPTER 2 Prime Movers

SECTION 1 Appendix 2 – Definition of Stress Concentration Factors in Crankshaft Fillets

Definition of Stress Concentration Factors in Crankshaft Fillets

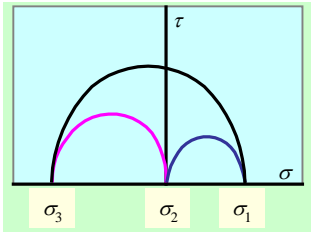
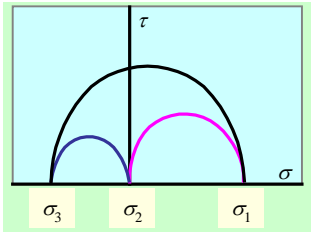
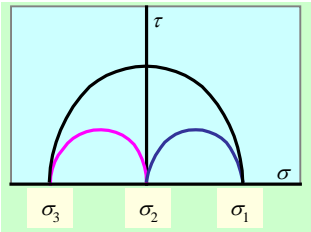
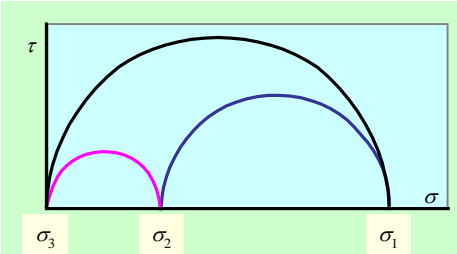
	Stress	Max $\ \sigma_3\ $	Max σ_1	
Torsional loading	Location of maximal stresses	A	C	B
	Typical principal stress system			
	Mohr's circle diagram with $\sigma_2 = 0$	$\ \sigma_3\ > \sigma_1$	$\sigma_1 > \ \sigma_3\ $	$\sigma_1 \approx \ \sigma_3\ $
Equivalent stress and S.C.F.	$\tau_{equiv} = \frac{\sigma_1 - \sigma_3}{2}$ $\text{S.C.F.} = \frac{\tau_{equiv}}{\tau_n} \text{ for } \alpha_T, \beta_T$			
Bending loading	Location of maximal stresses	B	B	B
	Typical principal stress system			
	Mohr's circle diagram with $\sigma_3 = 0$	$\sigma_2 \neq 0$		
Equivalent stress and S.C.F.	$\sigma_{equiv} = \sqrt{\sigma_1^2 + \sigma_2^2 - \sigma_1 \cdot \sigma_2}$ $\text{S.C.F.} = \frac{\sigma_{equiv}}{\sigma_n} \text{ for } \alpha_B, \beta_B, \beta_Q$			

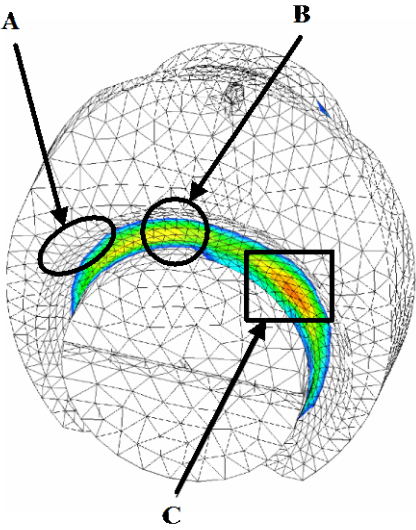

Note: For color version of figures, see Appendix 4-2-1A2 in the Rules for Building and Classing Marine Vessels on the ABS website: <http://www.eagle.org>

PART

4

CHAPTER 2 Prime Movers

SECTION 1 Appendix 3 –Stress Concentration Factors and
Stress Distribution at the Edge of Oil Drillings

Stress Concentration Factors and Stress Distribution at the Edge of Oil Drillings

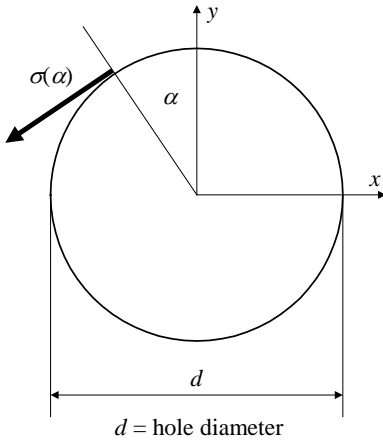

Stress type	Nominal stress tensor	Uniaxial stress distribution around the edge	Mohr's Circle diagram
Tension	$\begin{bmatrix} \sigma_n & 0 \\ 0 & 0 \end{bmatrix}$	$\sigma_\alpha = \sigma_n \gamma_B / 3 [1 + 2 \cos(2\alpha)]$	<p>$\gamma_B = \sigma_{\max} / \sigma_n$ for $\alpha = k\pi$</p>
Shear	$\begin{bmatrix} 0 & \tau_n \\ \tau_n & 0 \end{bmatrix}$	$\sigma_\alpha = \gamma_B \tau_n \sin(2\alpha)$	<p>$\gamma_T = \sigma_{\max} / \tau_n$ for $\alpha = \frac{\pi}{4} k \frac{\pi}{2}$</p>
Tension + Shear	$\begin{bmatrix} \sigma_n & \tau_n \\ \tau_n & 0 \end{bmatrix}$	$\sigma_\alpha = \frac{\gamma_B}{3} \sigma_n \left\{ 1 + 2 \left[\cos(2\alpha) + \frac{3}{2} \frac{\gamma_T}{\gamma_B} \frac{\tau_n}{\sigma_n} \sin(2\alpha) \right] \right\}$	<p>$\sigma_{\max} = \frac{\gamma_B}{3} \sigma_n \left[1 + 2 \sqrt{1 + \frac{9}{4} \left(\frac{\gamma_T}{\gamma_B} \frac{\tau_n}{\sigma_n} \right)^2} \right]$</p> <p>for $\alpha = \frac{1}{2} \text{tg}^{-1} \left(\frac{3\gamma_T \tau_n}{2\gamma_B \sigma_n} \right)$</p>

Note: For color version of figures, see Appendix 4-2-1A3 in the Rules for Building and Classing Marine Vessels on the ABS website:
<http://www.eagle.org>

PART

4

CHAPTER 2 Prime Movers

SECTION 1 Appendix 4 – Guidance for Spare Parts

1 General

While spare parts are not required for purposes of classification, the spare parts list below is provided as a guidance for vessels intended for unrestricted service. Depending on the design of the engine, spare parts other than those listed below, such as electronic control cards, should be considered.

3 Spare Parts for Main Propulsion Diesel Engines

<i>Item</i>	<i>Spare Part</i>	<i>Number Recommended</i>
1. Main bearings	Main bearings or shells for one bearing of each size and type fitted, complete with shims, bolts and nuts	1
2. Main thrust block	Pads for one face of Michell type thrust block, or	1 set
	Complete white metal thrust shoe of solid ring type, or	1
	Inner and outer race with rollers, where roller thrust bearings are fitted	1
3. Cylinder liner	Cylinder liner, complete with joint rings and gaskets	1
4. Cylinder cover	Cylinder cover, complete with valves, joint rings and gaskets.	1
	Cylinder cover bolts and nuts, for one cylinder	1/2 set
5. Cylinder valves	Exhaust valves, complete with casings, seats, springs and other fittings for one cylinder	2 sets
	Air inlet valves, complete with casings, seats, springs and other fittings for one cylinder	1 set
	Starting air valve, complete with casting, seat springs and other fittings	1
	Fuel valves of each size and type fitted, complete with all fittings, for one engine	1 set ^(a)
6. Connecting rod bearings	Bottom end bearings or shells of each size and type fitted, complete with shims, bolts and nuts, for one cylinder	1 set
	Top end bearings or shells of each size and type fitted, complete with shims, bolts and nuts, for one cylinder	1 set
7. Pistons	Crosshead type; piston of each type fitted, complete with piston rod, stuffing box, skirt, rings, studs and nuts	1
	Trunk piston type: piston of each type fitted, complete with skirt, rings, studs, nuts, gudgeon pin and connecting rod	1
8. Piston rings	Piston rings, for one cylinder	1 set
9. Piston cooling	Telescopic cooling pipes and fittings or their equivalent, for one cylinder unit	1 set
10. Cylinder lubricators	Lubricator, complete, of the largest size, with its chain drive or gear wheels, or equivalent spare part kit	1
11. Fuel injection pumps	Fuel pump complete or, when replacement at sea is practicable, a complete set of working parts for one pump (plunger, sleeve, valves, springs, etc.), or equivalent high pressure fuel pump (e.g., common rail pump or servo pump essential for operation of fuel injection system)	1
12. Fuel injection piping	High pressure double wall fuel pipe of each size and shape fitted, complete with couplings	1

<i>Item</i>	<i>Spare Part</i>	<i>Number Recommended</i>
13. Scavenge blower (including turbo chargers)	Rotors, rotor shafts, bearings, nozzle rings and gear wheels or equivalent working parts if other types	1 set ^(b)
14. Scavenging system	Suction and delivery valves for one pump of each type fitted	1 set
15. Reduction and/or reverse gear	Complete bearing bush, of each size fitted in the gear case assembly	1 set
	Roller or ball race, of each size fitted in the gear case assembly	1 set

Footnotes

- a) i) Engines with one or two fuel valves per cylinder: one set of fuel valves, complete.
 ii) Engines with three or more fuel valves per cylinder: two fuel valves complete per cylinder, and a sufficient number of valve parts, excluding the body, to form, with those fitted in the complete valves, a full engine set.
- b) The spare parts may be omitted where it has been demonstrated, at the Builder's test bench for one engine of the type concerned, that the engine can be maneuvered satisfactorily with one blower out of action.
- The requisite blanking and blocking arrangements for running with one blower out of action are to be available on board.

Notes:

- 1 The availability of other spare parts, such as gears and chains for camshaft drive, should be specially considered and decided upon by the owner.
- 2 It is assumed that the new crew has on board the necessary tools and equipment.
- 3 When the recommended spares are utilized, it is recommended that new spares are supplied as soon as possible.
- 4 In case of multi-engine installations, the minimum recommended spares are only necessary for one engine.
- 5 For electronically controlled engines spare parts as recommended by the engine designer/manufacturer.

5 Spare Parts for Auxiliary Diesel Engines

<i>Item</i>	<i>Spare Part</i>	<i>Number Recommended</i>
1. Main bearings	Main bearings or shells for one bearing of each size and type fitted, complete with shims, bolts and nuts	1
2. Cylinder valves	Exhaust valves, complete with casings, seats, springs and other fittings for one cylinder	2 sets
	Air inlet valves, complete with casings, seats, springs and other fittings for one cylinder	1 set
	Starting air valve, complete with casing, seat springs and other fittings	1
	Fuel valves of each size and type fitted, complete with all fittings, for one engine	1/2 set
3. Connecting rod bearings	Bottom end bearings or shells of each size and type fitted, complete with shims, bolts and nuts, for one cylinder	1 set
	Trunk piston type: gudgeon pin with bush for one cylinder	1 set
4. Piston rings	Piston rings, for one cylinder	1 set
5. Piston cooling	Telescopic cooling pipes and fittings or their equivalent, for one cylinder	1 set
6. Fuel injection pumps	Fuel pump complete or, when replacement at sea is practicable, a complete set of working parts for one pump (plunger, sleeve, valves, springs, etc.), or equivalent high pressure fuel pump (e.g., common rail pump or servo pump essential for operation of fuel injection system)	1
7. Fuel injection piping	High pressure double wall fuel pipe of each size and shape fitted, complete with couplings	1
8. Gaskets and packings	Special gaskets and packings of each size and type fitted, for cylinder covers and cylinder liners for one cylinder	1 set

Notes:

- 1 The availability of other spare parts should be specially considered and decided upon by the Owner.
- 2 It is assumed that the crew has on board the necessary tools and equipment.
- 3 When the recommended spares are utilized, it is recommended that new spares are supplied as soon as possible.
- 4 Where the number of generators of adequate capacity fitted for essential services exceeds the required number, spare parts may be omitted.
- 5 For electronically controlled engines spare parts as recommended by the engine designer/manufacture

PART

4

CHAPTER 2 Prime Movers

SECTION 1 Appendix 5 – Type Testing Procedure for Crankcase Explosion Relief Valves

1 Scope

This Appendix specifies type tests and identifies standard test conditions using methane gas and air mixture to demonstrate that crankcase explosion relief valves intended to be fitted to engines and gear cases are satisfactory.

This test procedure is only applicable to explosion relief valves fitted with flame arrestors.

Note: Where internal oil wetting of a flame arrester is a design feature of an explosion relief valve, alternative testing arrangements that demonstrate compliance with this Appendix may be proposed by the manufacturer. The alternative testing arrangements are to be agreed by ABS.

3 Recognized Standards

- i) EN 12874:2001: Flame arresters – Performance requirements, test methods and limits for use.
- ii) ISO/IEC EN 17025:2005: General requirements for the competence of testing and calibration laboratories.
- iii) EN 1070:1998: Safety of Machinery – Terminology.
- iv) VDI 3673: Part 1: Pressure Venting of Dust Explosions.
- v) IMO MSC/Circular 677 – Revised Standards for the Design, Testing and Locating of Devices to Prevent the Passage of Flame into Cargo Tanks in Tankers

5 Purpose

The purpose of type testing crankcase explosion relief valves is:

- i) To verify the effectiveness of the flame arrester.
- ii) To verify that the valve closes after an explosion.
- iii) To verify that the valve is gas/air tight after an explosion.
- iv) To establish the level of overpressure protection provided by the valve.

7 Test Facilities

Test facilities carrying out type testing of crankcase explosion relief valves are to meet the following requirements in order to be acceptable to ABS:

- i) The test facilities are to be accredited to a National or International Standard, e.g., ISO/IEC 17025 and are to be acceptable to ABS.
- ii) The test facilities are to be equipped so that they can perform and record explosion testing in accordance with this procedure.

- iii) The test facilities are to have equipment for controlling and measuring a methane gas in air concentration within a test vessel to an accuracy of $\pm 0.1\%$.
- iv) The test facilities are to be capable of effective point located ignition of methane gas in air mixture.
- v) The pressure measuring equipment is to be capable of measuring the pressure in the test vessel in at least two positions: one at the valve and the other at the test vessel center. The measuring arrangements are to be capable of measuring and recording the pressure changes throughout an explosion test at a frequency recognizing the speed of events during an explosion. The result of each test is to be documented by video recording and by recording with a heat sensitive camera.
- vi) The test vessel for explosion testing is to have documented dimensions. The dimensions are to be such that the vessel is not “pipe like” with the distance between dished ends being not more than 2.5 times its diameter. The internal volume of the test vessel is to include any standpipe arrangements.
- vii) The test vessel for explosion testing is to be provided with a flange, located centrally at one end perpendicular to the vessel longitudinal axis, for mounting the explosion relief valve. The test vessel is to be arranged in an orientation consistent with how the valve will be installed in service, i.e., in the vertical plane or the horizontal plane.
- viii) A circular plate is to be provided for fitting between the pressure vessel flange and valve tested with the following dimensions:
 - Outside diameter of 2 times the outer diameter of the valve top cover
 - Internal bore having the same internal diameter as the valve to be tested.
- ix) The test vessel is to have connections for measuring the methane in an air mixture at the top and bottom.
- x) The test vessel is to be provided with a means of fitting an ignition source at a position specified in 4-2-1A5/9.
- xi) The test vessel volume is to be, as far as practicable, related to the size and capability of the relief valve to be tested. In general, the volume is to correspond to the requirement in 4-2-1/7.1.2 for the free area of explosion relief valve to be not less than $115 \text{ cm}^2/\text{m}^3$ ($0.505 \text{ in}^2/\text{ft}^3$) of crankcase gross volume.

Notes:

- 1 This means that the testing of a valve having 1150 cm^2 (178.25 in^2) of free area, would require a test vessel with a volume of 10 m^3 (353.15 ft^3).
- 2 Where the free area of relief valves is greater than $115 \text{ cm}^2/\text{m}^3$ ($0.505 \text{ in}^2/\text{ft}^3$) of the crankcase gross volume, the volume of the test vessel is to be consistent with the design ratio.
- 3 In no case is the volume of the test vessel to vary by more than +15% to -15% from the design cm^2/m^3 volume ratio.

9 Explosion Test Process

All explosion tests to verify the functionality of crankcase explosion relief valves are to be carried out using an air and methane mixture with a volumetric methane concentration of $9.5\% \pm 0.5\%$. The pressure in the test vessel is to be not less than atmospheric and not exceed the opening pressure of the relief valve.

The concentration of methane in the test vessel is to be measured at the top and bottom of the vessel and these concentrations are not to differ by more than 0.5%.

The ignition of the methane and air mixture is to be made at the centerline of the test vessel at a position approximately one third of the height or length of the test vessel opposite to where the valve is mounted.

The ignition is to be made using a maximum 100 Joule (0.0947 BTU) explosive charge.

11 Valves to be Tested

- i) The valves used for type testing [including testing specified in 4-2-1A5/11iii)] are to be selected from the manufacturer's normal production line for such valves.
- ii) For approval of a specific valve size, three valves are to be tested in accordance with 4-2-1A5/11iii) and 4-2-1A5/13. For a series of valves, 4-2-1A5/17 refers.
- iii) The valves selected for type testing are to have been previously tested at the manufacturer's works to demonstrate that the opening pressure is in accordance with the specification within a tolerance of $\pm 20\%$ and that the valve is airtight at a pressure below the opening pressure for at least 30 seconds.
Note: This test is to verify that the valve is airtight following assembly at the manufacturer's works and that the valve begins to open at the required pressure demonstrating that the correct spring has been fitted.
- iv) The type testing of valves is to recognize the orientation in which they are intended to be installed on the engine or gear case. Three valves of each size are to be tested for each intended installation orientation, i.e., in the vertical and/or horizontal positions.

13 Method

13.1 General Requirements

The following requirements are to be satisfied during explosion testing:

- i) The explosion testing is to be witnessed by the Surveyor.
- ii) Where valves are to be installed on an engine or gear case with shielding arrangements to deflect the emission of explosion combustion products, the valves are to be tested with the shielding arrangements fitted.
- iii) Successive explosion testing to establish a valve's functionality is to be carried out as quickly as possible during stable weather conditions.
- iv) The pressure rise and decay during all explosion testing is to be recorded.
- v) The external condition of the valves is to be monitored during each test for indication of any flame release by video and heat sensitive camera.

13.3 Stages of Testing

The explosion testing is to be in three stages for each valve that is required to be approved as being type tested.

13.3.1 Stage 1

Two explosion tests are to be carried out in the test vessel with the circular plate described in 4-2-1A5/7viii) fitted and the opening in the plate covered by a 0.05 mm (0.002 inch) thick polythene film.

Note: These tests establish a reference pressure level for determination of the capability of a relief valve in terms of pressure rise in the test vessel [see 4-2-1A5/15vi)].

13.3.2 Stage 2

13.3.2(a) Two explosion tests are to be carried out on three different valves of the same size. Each valve is to be mounted in the orientation for which approval is sought, i.e., in the vertical or horizontal position with the circular plate described in 4-2-1A5/7viii) located between the valve and pressure vessel mounting flange.

13.3.2(b) The first of the two tests on each valve is to be carried out with a 0.05 mm (0.002 inch) thick polythene bag having a minimum diameter of three times the diameter of the circular plate and volume not less than 30% of the test vessel enclosing the valve and circular plate. Before carrying out the explosion test the polythene bag is to be empty of air. The polythene bag is required to provide a readily visible means of assessing whether there is flame transmission through the relief valve following an explosion consistent with the requirements of the standards identified in 4-2-1A5/3.

Note: During the test, the explosion pressure will open the valve and some unburned methane/ air mixture will be collected in the polythene bag. When the flame reaches the flame arrester and if there is flame transmission through the flame arrester, the methane/air mixture in the bag will be ignited and this will be visible.

13.3.2(c) Provided that the first explosion test successfully demonstrated that there was no indication of combustion outside the flame arrester and there are no visible signs of damage to the flame arrester or valve, a second explosion test without the polythene bag arrangement is to be carried out as quickly as possible after the first test. During the second explosion test, the valve is to be visually monitored for any indication of combustion outside the flame arrester and video records are to be kept for subsequent analysis. The second test is required to demonstrate that the valve can still function in the event of a secondary crankcase explosion.

13.3.2(d) After each explosion, the test vessel is to be maintained in the closed condition for at least 10 seconds to enable the tightness of the valve to be ascertained. The tightness of the valve can be verified during the test from the pressure/time records or by a separate test after completing the second explosion test.

13.3.3 Stage 3

Carry out two further explosion tests as described in Stage 1, (see 4-2-1A5/13.3.1). These further tests are required to provide an average base line value for assessment of pressure rise recognizing that the test vessel ambient conditions may have changed during the testing of the explosion relief valves in Stage 2, (see 4-2-1A5/13.3.2).

15 Assessment and Records

For the purposes of verifying compliance with the requirements of this Appendix, the assessment and records of the valves used for explosion testing is to address the following items:

- i) The valves to be tested are to have been design approved.
- ii) The designation, dimensions and characteristics of the valves to be tested are to be recorded. This is to include the valve free area of the valve and of the flame arrester and the amount of valve lift at 0.2 bar (0.2 kgf/cm², 2.85 lbf/in²).
- iii) The test vessel volume is to be determined and recorded.
- iv) For acceptance of the functioning of the flame arrester there must not be any indication of flame or combustion outside the valve during an explosion test. This is to be confirmed by the test laboratory taking into account measurements from the heat sensitive camera.
- v) The pressure rise and decay during an explosion is to be recorded with indication of the pressure variation showing the maximum overpressure and steady under pressure in the test vessel during testing. The pressure variation is to be recorded at two points in the pressure vessel.
- vi) The effect of an explosion relief valve in terms of pressure rise following an explosion is ascertained from maximum pressures recorded at the center of the test vessel during the three stages. The pressure rise within the test vessel due to the installation of a relief valve is the difference between average pressure of the four explosions from Stages 1 and 3 (see 4-2-1A5/13.3.1 and 4-2-1A5/13.3.3) and the average of the first tests on the three valves in Stage 2, (see 4-2-1A5/13.3.2). The pressure rise is not to exceed the limit specified by the manufacturer.
- vii) The valve tightness is to be ascertained by verifying from records at the time of testing that an underpressure of at least 0.3 bar (3.06 kgf/cm², 43.5 psi) is held by the test vessel for at least 10 seconds following an explosion. The test is to verify that the valve has effectively closed and is reasonably gas-tight following dynamic operation during an explosion.
- viii) After each explosion test in Stage 2, (see 4-2-1A5/13.3.2), the external condition of the flame arrester is to be examined for signs of serious damage and/or deformation that may affect the operation of the valve.
- ix) After completing the explosion tests, the valves are to be dismantled and the condition of all components ascertained and documented. In particular, any indication of valve sticking or uneven opening that may affect operation of the valve is to be noted. Photographic records of the valve condition are to be taken and included in the report.

17 Design Series Qualification

17.1 General

The qualification of quenching devices to prevent the passage of flame can be evaluated for other similar devices of identical type, where one device has been tested and found satisfactory.

17.3 Flame Arrester

The quenching ability of a flame arrester depends on the total mass of quenching lamellas/mesh. Provided the materials, thickness of materials, depth of lamellas/thickness of mesh layer and the quenching gaps are the same, then the same quenching ability can be qualified for different size flame arresters. This is subject to i) and ii) being satisfied.

$$i) \quad \frac{n_1}{n_2} = \sqrt{\frac{S_1}{S_2}}$$

$$ii) \quad \frac{A_1}{A_2} = \frac{S_1}{S_2}$$

where

n_1 = total depth of flame arrester corresponding to the number of lamellas of size 1 quenching device for a valve with a relief area equal to S_1

n_2 = total depth of flame arrester corresponding to the number of lamellas of size 2 quenching device for a valve with a relief area equal to S_2

A_1 = free area of quenching device for a valve with a relief area equal to S_1

A_2 = free area of quenching device for a valve with a relief area equal to S_2

17.5 Valves of Larger Sizes than Have Been Satisfactorily Tested

The qualification of explosion relief valves of larger sizes than that which has been previously satisfactorily tested in accordance with 4-2-1A5/13 and 4-2-1A5/15 can be evaluated where valves are of identical type and have identical features of construction subject to the following:

17.5.1

The free area of a larger valve does not exceed three times +5% that of the valve that has been satisfactorily tested.

17.5.2

One valve of the largest size, subject to 4-2-1A5/17.5.1, requiring qualification is subject to satisfactory testing required by 4-2-1A5/11iii) and 4-2-1A5/13.3.2 except that a single valve will be accepted in 4-2-1A5/13.3.2(a) and the volume of the test vessel is not to be less than one third of the volume required by 4-2-1A5/7xi).

17.5.3

The assessment and records are to be in accordance with 4-2-1A5/15 noting that 4-2-1A5/15vi) will only be applicable to Stage 2 for a single valve.

17.7 Valves of Smaller Sizes than Have Been Satisfactorily Tested

The qualification of explosion relief valves of smaller sizes than that which has been previously satisfactorily tested in accordance with 4-2-1A5/13 and 4-2-1A5/15 can be evaluated where valves are of identical type and have identical features of construction subject to the following:

17.7.1

The free area of a smaller valve is not less than one-third of the valve that has been satisfactorily tested.

17.7.2

One valve of the smallest size, subject to 4-2-1A5/17.7.1, requiring qualification is subject to satisfactory testing required by 4-2-1A5/11iii) and 4-2-1A5/13.3.2 except that a single valve will be accepted in 4-2-1A5/13.3.2(a) and the volume of the test vessel is not to be more than the volume required by 4-2-1A5/7xi).

17.7.3

The assessment and records are to be in accordance with 4-2-1A5/15 noting that 4-2-1A5/15vi) will only be applicable to Stage 2 for a single valve.

19 Reporting

The test facility is to provide a full report that includes the following information and documents:

- i)* Test specification.
- ii)* Details of test pressure vessel and valves tested.
- iii)* The orientation in which the valve was tested, (vertical or horizontal position).
- iv)* Methane in air concentration for each test.
- v)* Ignition source
- vi)* Pressure curves for each test.
- vii)* Video recordings of each valve test.
- viii)* The assessment and records stated in 4-2-1A5/15.

21 Acceptance

Acceptance of an explosion relief valve will be based on design approved plans and particulars and on the test facility's report of the results of the type testing.

PART

4

CHAPTER 2 Prime Movers

SECTION 1 Appendix 6 – Type Testing Procedure for Crankcase Oil Mist Detection and Alarm Equipment

1 Scope

This Appendix specifies the tests required to demonstrate that crankcase oil mist detection and alarm equipment intended to be fitted to diesel engines demonstrate compliance with a defined standard for type testing.

Note: This test procedure is also applicable to oil mist detection and alarm equipment intended for gear cases.

3 Recognized Environmental Test Standards

Equipment tests as required in 4-2-1/9 are to in accordance with 4-9-9/Table 1

5 Purpose

The purpose of type testing crankcase oil mist detection and alarm equipment is:

- i)* To verify the functionality of the system.
- ii)* To verify the effectiveness of the oil mist detectors.
- iii)* To verify the accuracy of oil mist detectors.
- iv)* To verify the alarm set points.
- v)* To verify time delays between oil mist leaving the source and alarm activation.
- vi)* To verify functional failure detection.
- vii)* To verify the influence of optical obscuration on detection.

7 Test Facilities

Test facilities for carrying out type testing of crankcase oil mist detection and alarm equipment are to satisfy the following criteria:

- i)* A full range of provisions for carrying out the environmental and functionality tests required by this procedure are to be available and acceptable to ABS.
- ii)* The test facility that verifies the functionality of the equipment is to be equipped so that it can control, measure and record oil mist concentration levels in terms of mg/l to an accuracy of $\pm 10\%$ accordance with this procedure.
- iii)* When verifying the functionality, test facilities are to consider the possible hazards associated with the generation of the oil mist required and take adequate precautions. The use of low toxicity, low hazard oils as used in other applications will be accepted, provided it is demonstrated to have similar properties to SAE 40 monograde mineral oil specified.

9 Equipment Testing

The range of tests is to include the following (see also 4-9-9/13.1 – Prototype Environmental Testing):

9.1 For the Alarm/Monitoring Panel

- i) Functional tests described in 4-2-1A6/11.
- ii) Electrical power supply failure test.
- iii) Power supply variation test.
- iv) Dry heat test.
- v) Damp heat test.
- vi) Vibration test.
- vii) EMC test.
- viii) Insulation resistance test.
- ix) High voltage test.
- x) Static and dynamic inclinations, if moving parts are contained.

9.3 For the Detectors

- i) Functional tests described in 4-2-1A6/11.
- ii) Electrical power supply failure test.
- iii) Power supply variation test.
- iv) Dry heat test.
- v) Damp heat test.
- vi) Vibration test.
- vii) EMC test where susceptible.
- viii) Insulation resistance test.
- ix) High voltage test.
- x) Static and dynamic inclinations.

11 Functional Tests

- i) All tests to verify the functionality of crankcase oil mist detection and alarm equipment are to be carried out in accordance with 4-2-1A6/11ii) through 4-2-1A6/11vi) with an oil mist concentration in air, known in terms of mg/l to an accuracy of $\pm 10\%$.
- ii) The concentration of oil mist in the test chamber is to be measured in the top and bottom of the chamber and these concentrations are not to differ by more than 10%. See also 4-2-1A6/15i)a).
- iii) The oil mist detector monitoring arrangements are to be capable of detecting oil mist in air concentrations of between 0 and 10% of the lower explosive limit (LEL) or between 0 and a percentage of weight of oil in air determined by the Manufacturer based on the sensor measurement method (e.g., obscuration or light scattering) that is acceptable to ABS taking into account the alarm level specified in iv) below. Note: The LEL corresponds to an oil mist concentration of approximately 50 mg/l (~4.1% weight of oil-in air mixture).
- iv) The alarm set point for oil mist concentration in air is to provide an alarm at a maximum level corresponding to not more than 5% of the LEL or approximately 2.5 mg/l.
- v) Where alarm set points can be altered, the means of adjustment and indication of set points are to be verified against the equipment manufacturer's instructions.

- vi) The performance of the oil mist detector in mg/l is to be demonstrated. This is to include: range (oil mist detector); resolution (oil mist detector); sensitivity (oil mist detector).
- Sensitivity of a measuring system: quotient of the change in an indication of a measuring system and the corresponding change in a value of a quantity being measured.
- Resolution: smallest change in a quantity being measured that causes a perceptible change in the corresponding indication.
- vii) Where oil mist is drawn into a detector/monitor via piping arrangements, the time delay between the sample leaving the crankcase and operation of the alarm is to be determined for the longest and shortest lengths of pipes recommended by the manufacturer. The pipe arrangements are to be in accordance with the manufacturer's instructions/recommendations. Piping is to be arranged to prevent pooling of oil condensate which may cause a blockage of the sampling pipe over time.
- viii) It is to be demonstrated that openings in detector equipment that is in contact with the crankcase atmosphere and may be exposed to oil splash and spray from engine lubricating oil do not occlude or become blocked under continuous oil splash and spray conditions. Testing is to be in accordance with arrangements proposed by the manufacturer and agreed by ABS. The temperature, quantity and angle of impact of the oil to be used is to be declared and their selection justified by the manufacturer.
- ix) It is to be demonstrated that exposed to water vapor from the crankcase atmosphere, which may affect the sensitivity of the detector equipment, will not affect the functional operation of the detector equipment. Where exposure to water vapor and/or water condensation has been identified as a possible source of equipment malfunctioning, testing is to demonstrate that any mitigating arrangements, such as heating, are effective. Testing is to be in accordance with arrangements proposed by the manufacturer and agreed by ABS.
- Note:* This testing is in addition to that required by 4-2-1A6/9.3v) and is concerned with the effects of condensation caused by the detection equipment being at a lower temperature than the crankcase atmosphere.
- x) It is to be demonstrated that an indication is given where lenses fitted in the equipment and used in determination of the oil mist level have been partially obscured to a degree that will affect the reliability of the information and alarm indication.

13 Detectors and Alarm Equipment to be Tested

The detectors and alarm equipment selected for the type testing are to be selected by the Surveyor from the manufacturer's usual production line.

Two detectors are to be tested. One is to be tested in the clean condition and the other in a condition representing the maximum level of lens obscuration specified by the manufacturer.

15 Method

The following requirements are to be satisfied during type testing:

- i) Oil mist generation is to satisfy 4-2-1A6/15i)a) to 4-2-1A6/15i)f).
- a) The ambient temperature in and around the test chamber is to be at the standard atmospheric conditions defined in Section 4-9-8 for Type Approval before any test run is started.
- b) Oil mist is to be generated with suitable equipment using an SAE 40 monograde mineral oil or equivalent and supplied to a test chamber. The selection of the oil to be used is to take into consideration risks to health and safety, and the appropriate controls implemented. A low toxicity, low flammability oil of similar viscosity may be used as an alternative. The oil mist produced is to have an average (or arithmetic mean) droplet size not exceeding 5 µm. The oil droplet size is to be checked using the sedimentation method or an equivalent method to a relevant international or national standard. If the sedimentation method is chosen, the test chamber is to have a minimum height of 1 m and a volume of not less than 1 m³.

Note: The calculated oil droplet size using the sedimentation method represents the average droplet size.

- c) The oil mist concentrations used are to be ascertained by the gravimetric deterministic method or equivalent. Where an alternative technique is used its equivalence is to be demonstrated.
- Note:* For this test, the gravimetric deterministic method is a process where the difference in weight of a 0.8 µm pore size membrane filter is ascertained from weighing the filter before and after drawing 1 liter of oil mist through the filter from the oil mist test chamber. The oil mist chamber is to be fitted with a recirculating fan.
- d) Samples of oil mist are to be taken at regular intervals and the results plotted against the oil mist detector output. The oil mist detector is to be located adjacent to where the oil mist samples are drawn off.
- e) The results of a gravimetric analysis are considered invalid and are to be rejected if the resultant calibration curve has an increasing gradient with respect to the oil mist detection reading. This situation occurs when insufficient time has been allowed for the oil mist to become homogeneous. Single results that are more than 10% below the calibration curve are to be rejected. This situation occurs when the integrity of the filter unit has been compromised and not all of the oil is collected on the filter paper.
- f) The filters require to be weighed to a precision of 0.1 mg and the volume of air/oil mist sampled to 10 ml.
- ii) The testing is to be witnessed by the Surveyor.
- iii) Oil mist detection equipment is to be tested in the orientation (vertical, horizontal or inclined) in which it is intended to be installed on an engine or gear case as specified by the equipment manufacturer.
- iv) Type testing is to be carried out for each type of oil mist detection and alarm equipment for which a manufacturer seeks approval. Where sensitivity levels can be adjusted, testing is to be carried out at the extreme and mid-point level settings.

17 Assessment

Assessment of oil mist detection equipment after testing is to address the following:

- i) The equipment to be tested is to have been design approved.
- ii) Details of the detection equipment to be tested are to be recorded, such as name of manufacturer, type designation, oil mist concentration assessment capability and alarm settings, and the maximum percentage level of lens obscuration used in 4-2-1A6/13.
- iii) After completing the tests, the detection equipment is to be examined and the condition of all components ascertained and documented. Photographic records of the monitoring devices condition are to be taken and included in the report.

19 Design Series Qualification

The approval of one type of detection equipment may be used to qualify other devices having identical construction details. Proposals are to be submitted for consideration.

21 Reporting

The test facility is to provide a full report which includes the following information and documents:

- i) Test specification.
- ii) Details of equipment tested.
- iii) Results of tests, to include a declaration by the manufacturer of the oil mist detector of the following:
- Performance, in mg/L
 - Accuracy, of oil mist concentration in air

- Precision, of oil mist concentration in air
- Range, of oil mist detector
- Resolution, of oil mist detector
- Response time, of oil mist detector
- Sensitivity, of oil mist detector
- Obscuration of sensor detection, declared as percentage of obscuration. 0% totally clean, 100% totally obscure
- Detector failure alarm

23 Acceptance

Acceptance of crankcase oil mist detection equipment will be based on design approved plans and particulars and on the test facility's report of the results of the type testing.

The following information is to be submitted for acceptance of oil mist detection equipment and alarm arrangements:

- i)* Description of oil mist detection equipment and system including alarms.
- ii)* Copy of the test facility's report identified in 4-2-1A6/21.
- iii)* Schematic layout of engine oil mist detection arrangements showing location of detectors/ sensors and piping arrangements and dimensions.
- iv)* Maintenance and test manual which is to include the following information:
 - Intended use of equipment and its operation.
 - Functionality tests to demonstrate that the equipment is operational and that any faults can be identified and corrective actions notified.
 - Maintenance routines and spare parts recommendations.
 - Limit setting and instructions for safe limit levels.
 - Where necessary, details of configurations in which the equipment is intended to be used and in which it is not to be used.

PART

4

CHAPTER 2 Prime Movers

SECTION 1 Appendix 7 – Alternative Method for Calculation of Stress Concentration Factors in the Web Fillet Radii of Crankshafts by Utilizing Finite Element Method

1 General

The objective of the analysis is to develop Stress Concentration Factors (SCF) by applying the Finite Element Method (FEM) as an alternative to the analytically calculated SCF's at the crankshaft fillets in 4-2-1/5.9.4. The analytical method is based on empirical formulae developed from strain gauge measurements of various crank geometries and accordingly the application of these formulae is limited to those geometries.

The SCF's calculated in accordance with this Appendix are defined as the ratio of stresses calculated by FEM to nominal stresses in both journal and pin fillets. When used in connection with the analytical method in 4-2-1/5.9.4 or this alternative method, von Mises stresses is to be calculated for bending and principal stresses for torsion.

The procedure as well as evaluation guidelines are valid for both solid cranks and semi-built cranks (with the exception of the journal fillets).

The analysis is to be conducted as a linear elastic FE analysis, and unit loads of appropriate magnitude are to be applied for all load cases.

The calculation of SCF at the oil bores is not addressed by this Appendix.

The element accuracy of the FE solver used is to be checked (e.g., by modeling a simple geometry and comparing the stresses obtained by FEM with the analytical solution for pure bending and torsion).

The Boundary Element Method (BEM) may be used instead of FEM.

3 Model Requirements

The basic recommendations and perceptions for building the FE-model are presented in 4-2-1A7/3.1. It is obligatory for the final FE-model to fulfill the requirement in 4-2-1A7/3.5.

3.1 Element Mesh Recommendations

To fulfill the mesh quality criteria for the evaluation of SCF's, it is recommended to construct the FE model as follows:

- i) The model consists of one complete crank, from the main bearing centerline to the opposite side main bearing centerline.
- ii) Element types used in the vicinity of the fillets:
 - 10 node tetrahedral elements
 - 8 node hexahedral elements
 - 20 node hexahedral elements

- iii) Mesh properties in fillet radii. The following applies to ± 90 degrees in circumferential direction from the crank plane:
- iv) Maximum element size $a = r/4$ through the entire fillet as well as in the circumferential direction. When using 20 node hexahedral elements, the element size in the circumferential direction may be extended up to $5a$. In the case of multi-radii fillet r is the local fillet radius. (If 8 node hexahedral elements are used even smaller element size is required to meet the quality criteria.)
- v) Recommended manner for element size in fillet depth direction
 - First layer thickness equal to element size of a
 - Second layer thickness equal to element to size of $2a$
 - Third layer thickness equal to element to size of $3a$
- vi) Minimum 6 elements across web thickness.
- vii) Generally the rest of the crank should be suitable for numeric stability of the solver.
- viii) Counterweights have to be modeled only when influencing the global stiffness of the crank significantly.
- ix) Modeling of oil drillings is not necessary as long as the influence on global stiffness is negligible and the proximity to the fillet is more than $2r$, see 4-2-1A7//Figure 1.
- x) Drillings and holes for weight reduction have to be modeled.
- xi) Sub-modeling may be used provided the software requirements are fulfilled.

FIGURE 1
Oil Bore Proximity to Fillet

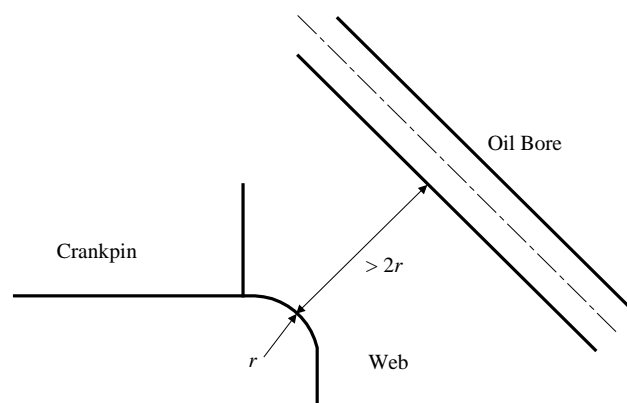

3.3 Materials

Material properties such as Young's Modulus (E) and Poisson's ratio (ν) are not considered. In FE analysis those material parameters are required, as strain is primarily calculated and stress is derived from strain using Young's Modulus and Poisson's ratio. Reliable values for material parameters have to be used, either as quoted in literature or as measured on representative material samples.

For steel the following is advised: $E = 2.05 \cdot 10^5$ MPa and $\nu = 0.3$.

3.5 Element Mesh Quality Criteria

If the actual element mesh does not fulfill any of the following criteria at the examined area for SCF evaluation, then a second calculation with a refined mesh is to be performed.

3.5.1 Principal Stresses Criterion

The quality of the mesh should be checked by noting the stress component normal to the surface of the fillet radius. Ideally, this stress should be zero. With principal stresses σ_1 , σ_2 , and σ_3 the following criterion is required:

$$\min (|\sigma_1|, |\sigma_2|, |\sigma_3|) < 0.03 \max (|\sigma_1|, |\sigma_2|, |\sigma_3|)$$

3.5.2 Averaged/Unaveraged Stresses Criterion

The criterion is based on observing the discontinuity of stress results over elements at the fillet for the calculation of SCF:

- Unaveraged nodal stress results calculated from each element connected to a node should differ less than 5% from the 100% averaged nodal stress results at this node at the examined location.

5 Load Cases

To substitute the analytically determined SCF in 4-2-1/5.9.4 the following load cases are to be calculated.

5.1 Torsion

Similar to the testing apparatus arrangements used for the investigations of SCF's of web fillet radii the structure is loaded in pure torsion. In the model surface warp at the end faces is suppressed. See 4-2-1A7/Figure 2.

Torque is applied to the central node located at the crankshaft axis. This node acts as the master node with 6 degrees of freedom and is connected rigidly to all nodes of the end face.

Boundary and load conditions are valid for both in-line and V-type engines.

For all nodes in both the journal and crank pin fillet principal stresses are extracted and the equivalent torsional stress is calculated:

$$\tau_{equiv} = \max \left(\frac{|\sigma_1 - \sigma_2|}{2}, \frac{|\sigma_2 - \sigma_3|}{2}, \frac{|\sigma_1 - \sigma_3|}{2} \right)$$

The maximum value taken for the subsequent calculation of the SCF:

$$\alpha_T = \frac{\tau_{equiv,\alpha}}{\tau_N}$$

$$\beta_T = \frac{\tau_{equiv,\beta}}{\tau_N}$$

where τ_N is nominal torsional stress referred to the crankpin and respectively journal as per 4-2-1/5.9.3 with the torsional torque T :

$$\tau_N = \frac{T}{W_P}$$

FIGURE 2
Boundary and Load Conditions for the Torsion Load Case

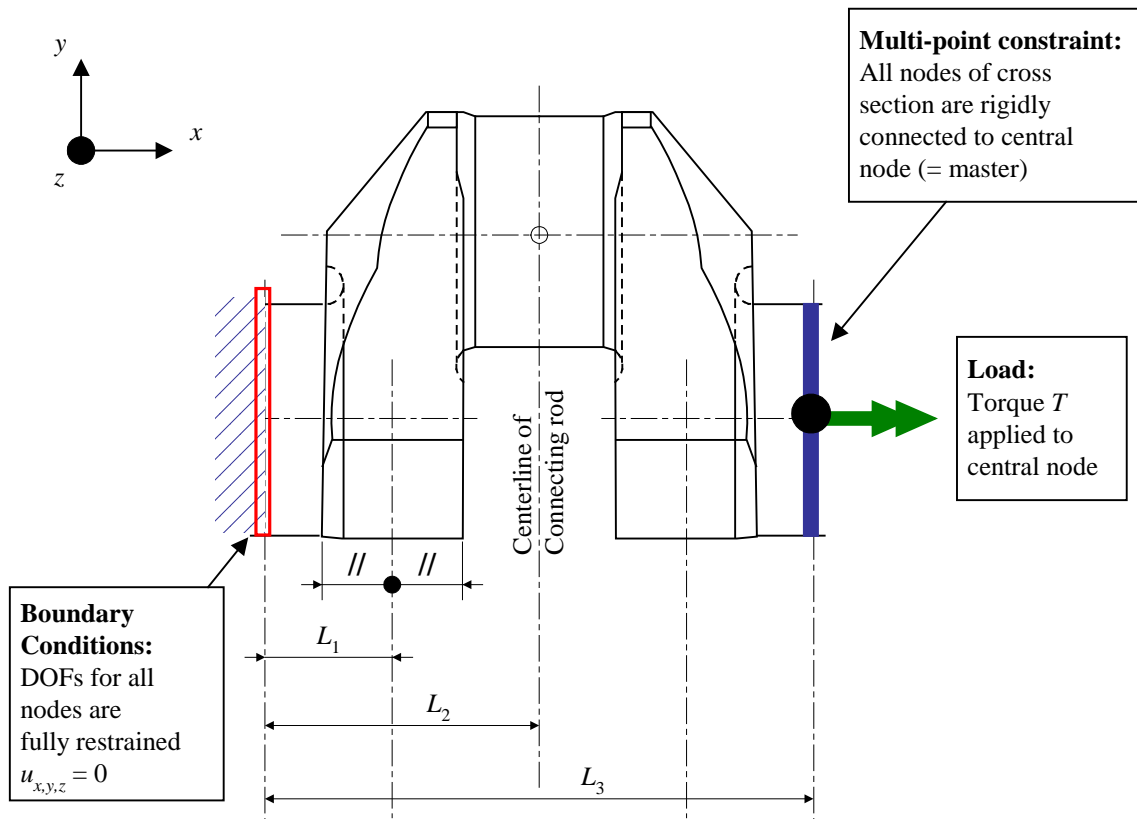

5.3 Pure Bending (4 Point Bending)

Similar to the testing apparatus arrangements used for the investigations of SCF's of web fillet radii the structure is loaded in pure bending. In the model surface warp at the end faces is suppressed. See 4-2-1A7/Figure 3.

The bending moment is applied to the central node located at the crankshaft axis. This node acts as the master node with 6 degrees of freedom and is connected rigidly to all nodes of the end face.

Boundary and load conditions are valid for both in-line and V- type engines.

For all nodes in both the journal and pin fillet von Mises equivalent stresses σ_{equiv} are extracted. The maximum value is used to calculate the SCF according to:

$$\alpha_B = \frac{\sigma_{equiv,\alpha}}{\sigma_N}$$

$$\beta_B = \frac{\sigma_{equiv,\beta}}{\sigma_N}$$

Nominal stress σ_N is calculated as per 4-2-1/5.9.3 with the bending moment M :

$$\sigma_N = \frac{M}{W_{eqw}}$$

FIGURE 3
Boundary and Load Conditions for the Pure Bending Load Case

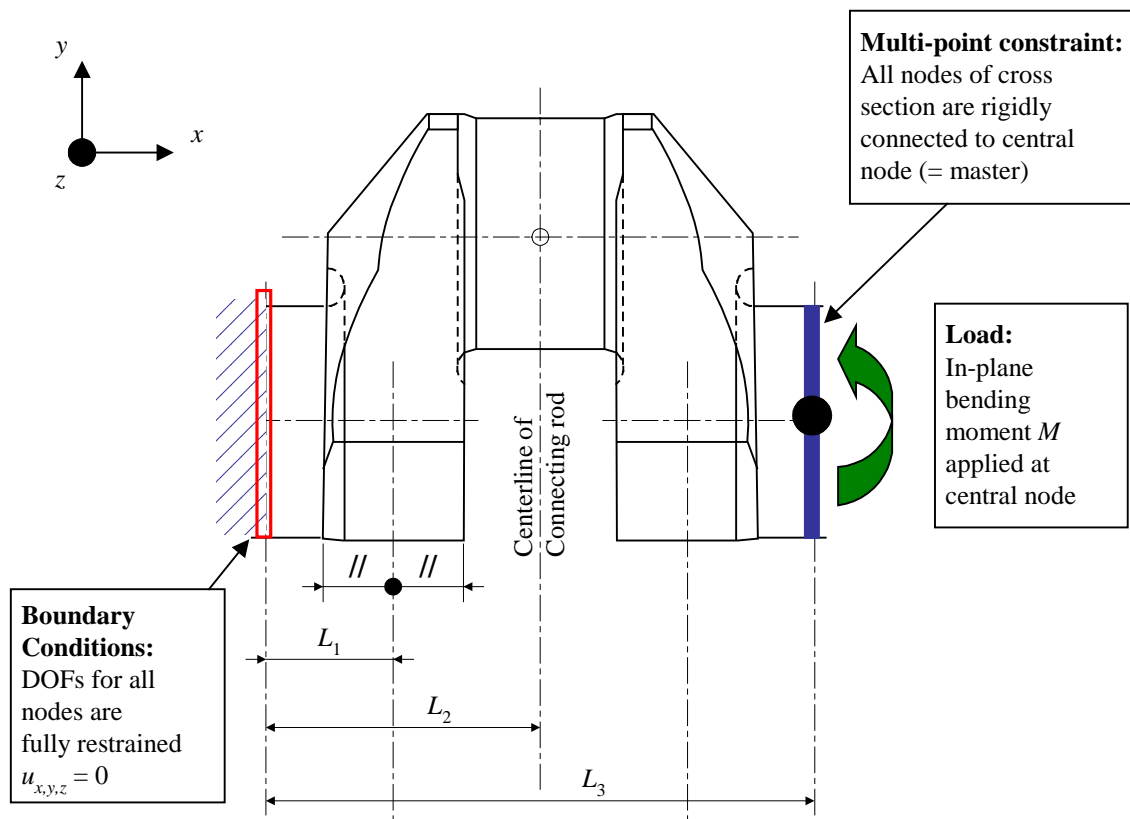

5.5 Bending With Shear Force (3 Point Bending)

This load case is calculated to determine the SCF for pure transverse force (radial force, β_Q) for the journal fillet.

Similar to the testing apparatus arrangements used for the investigations of SCF's of web fillet radii, the structure is loaded in 3-point bending. In the model, surface warp at the both end faces is suppressed. All nodes are connected rigidly to the center node; boundary conditions are applied to the center nodes. These nodes act as master nodes with 6 degrees of freedom. See 4-2-1A7/Figure 4.

The force is applied to the central node located at the pin centerline of the connecting rod. This node is connected to all nodes of the pin cross sectional area. Warping of the sectional area is not suppressed.

Boundary and load conditions are valid for in-line and V-type engines. V-type engines can be modeled with one connecting rod force only. Using two connecting rod forces will make no significant change in the SCF.

The maximum equivalent von Mises stress σ_{3p} in the journal fillet is evaluated. The SCF in the journal fillet can be determined in two ways as shown below.

FIGURE 4
Boundary and Load Conditions for the 3-Point Bending Load Case of an Inline Engine

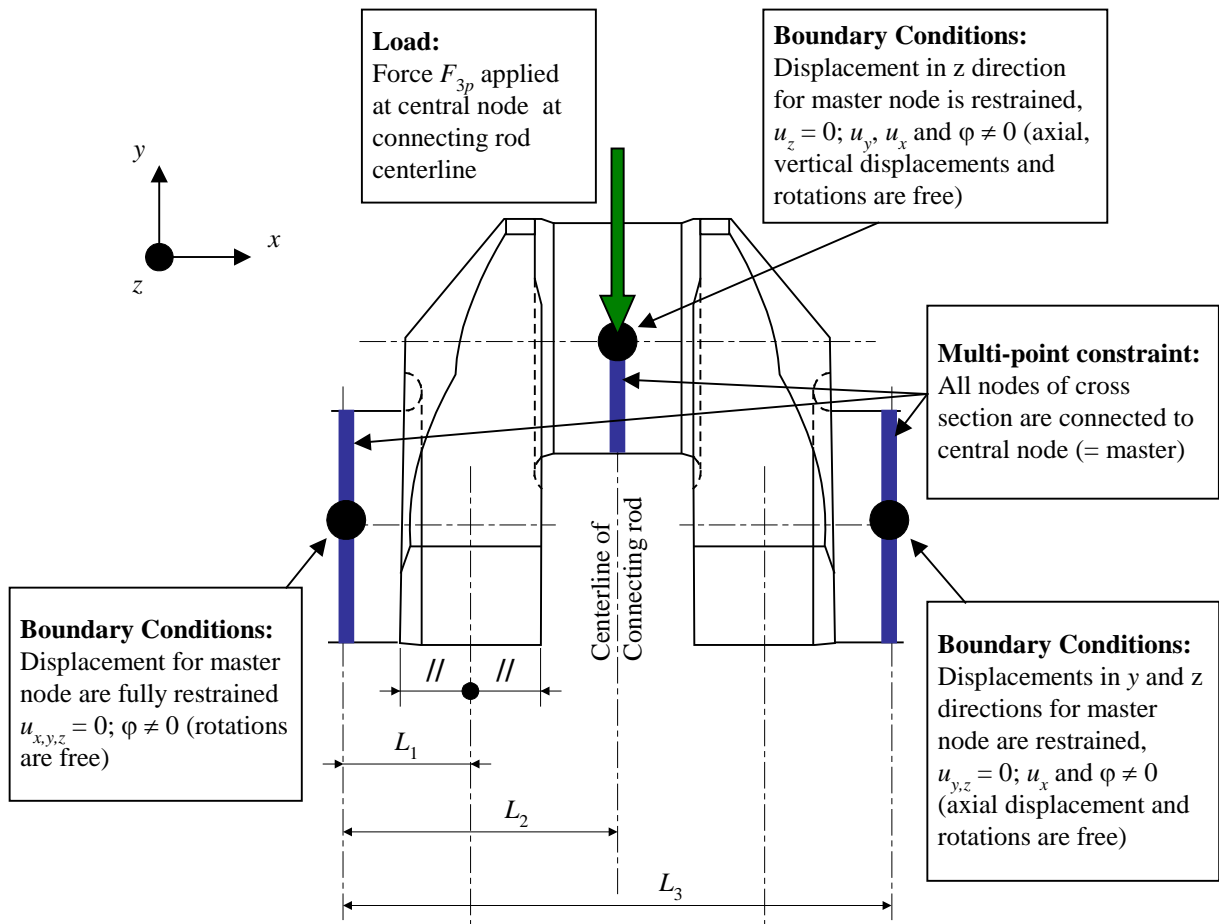

5.5.1 Method 1

This method is based on the testing apparatus arrangements used for the investigations of SCF's of web fillet radii. The results from 3-point and 4-point bending are combined as follows:

$$\sigma_{3P} = \sigma_{N3P} \cdot \beta_B + \sigma_{Q3P} \cdot \beta_Q$$

where:

σ_{3P} = as found by the FE calculation.

σ_{N3P} = nominal bending stress in the web center due to the force F_{3P} [N] applied to the centerline of the actual connecting rod, See 4-2-1A7/Figure 5.

β_B = as determined in paragraph 4-2-1A7/5.3.

$$\sigma_{Q3P} = \frac{Q_{3P}}{B \cdot W}$$

Q_{3P} = radial (shear) force in the web due to the force F_{3P} [N] applied to the centerline of the actual connecting rod, see also 4-2-1/Figure 3 and 4-2-1/Figure 4.

FIGURE 5
Load Applications for In-line and V-type Engines

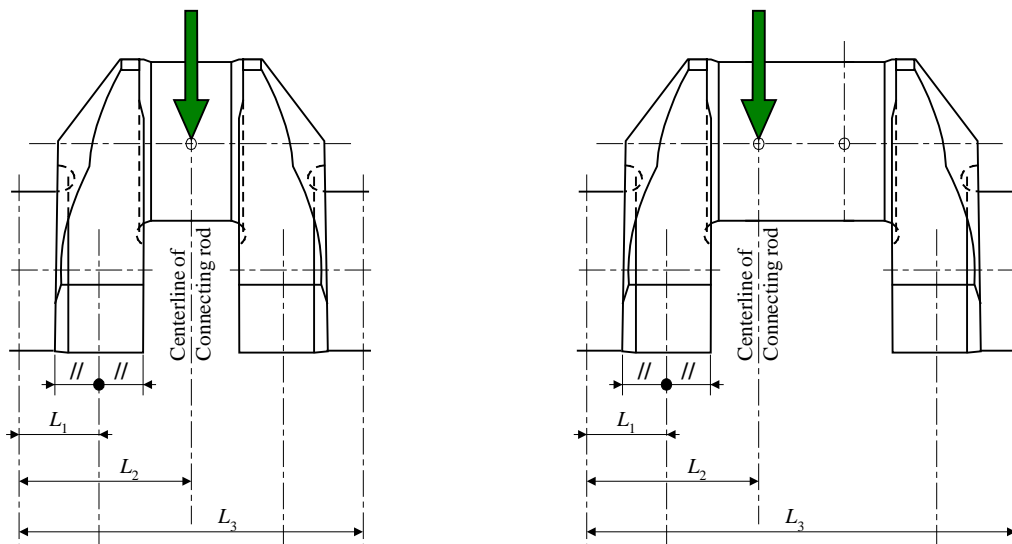

5.5.2 Method 2

This method is not based on the testing apparatus arrangements investigation. In a statically determined system with one crank throw supported by two bearings, the bending moment and radial (shear) force are proportional. Therefore the journal fillet SCF can be found directly by the 3-point bending FE calculation.

The SCF is then calculated according to:

$$\beta_{EQ} = \frac{\sigma_{3P}}{\sigma_{N3P}}$$

For symbols see 4-2-1A7/5.5.1.

When using this method the radial force and stress determination in 4-2-1/5.9 become superfluous. The alternating bending stress in the journal fillet as per 4-2-1/5.9.2(c) is then evaluated:

$$\sigma_{BG} = \pm |\beta_{BQ} \cdot \sigma_{BFN}|$$

Note that the use of this method does not apply to the crankpin fillet and that this SCF must not be used in connection with calculation methods other than those assuming a statically determined system as in 4-2-1/5.9.

PART

4

CHAPTER 2 Prime Movers

SECTION 1 Appendix 8 – Guidance for Evaluation of Fatigue Tests (1 July 2018)

1 Introduction

Fatigue testing can be divided into two main groups; testing of small specimens and full-size crank throws. Testing can be made using the staircase method or a modified version thereof which is presented in this document. Other statistical evaluation methods may also be applied.

1.1 Small Specimen Testing

For crankshafts without any fillet surface treatment, the fatigue strength can be determined by testing small specimens taken from a full-size crank throw. When other areas in the vicinity of the fillets are surface treated introducing residual stresses in the fillets, this approach cannot be applied.

One advantage of this approach is the rather high number of specimens which can be then manufactured. Another advantage is that the tests can be made with different stress ratios (R-ratios) and/or different modes (e.g., axial, bending and torsion), with or without a notch. This is required for evaluation of the material data to be used with critical plane criteria.

1.3 Full-size Crank Throw Testing

For crankshafts with surface treatment the fatigue strength can only be determined through testing of full size crank throws. For cost reasons, this usually means a low number of crank throws. The load can be applied by hydraulic actuators in a 3- or 4-point bending arrangement, or by an exciter in a resonance test rig. The latter is frequently used, although it usually limits the stress ratio to $R = -1$.

3 Evaluation of Test Results

3.1 Principles

Prior to fatigue testing the crankshaft must be tested as required by quality control procedures (e.g., for chemical composition, mechanical properties, surface hardness, hardness depth and extension, fillet surface finish, etc.).

The test samples should be prepared so as to represent the “lower end” of the acceptance range (e.g., for induction hardened crankshafts this means the lower range of acceptable hardness depth, the shortest extension through a fillet, etc.). Otherwise the mean value test results should be corrected with a confidence interval: a 90% confidence interval may be used both for the sample mean and the standard deviation.

The test results, when applied in 4-2-1/5.9, are to be evaluated to represent the mean fatigue strength, with or without taking into consideration the 90% confidence interval as mentioned above. The standard deviation should be considered by taking the 90% confidence into account. Subsequently the result to be used as the fatigue strength is then the mean fatigue strength minus one standard deviation.

If the evaluation aims to find a relationship between (static) mechanical properties and the fatigue strength, the relation must be based on the real (measured) mechanical properties, not on the specified minimum properties.

The calculation technique presented in 4-2-1A8/11 was developed for the original staircase method. However, since there is no similar method dedicated to the modified staircase method the same is applied for both.

5 Small Specimen Testing

In this connection, a small specimen is considered to be one of the specimens taken from a crank throw. Since the specimens shall be representative for the fillet fatigue strength, they should be taken out close to the fillets, as shown in 4-2-1A8/Figure 1. It should be made certain that the principal stress direction in the specimen testing is equivalent to the full-size crank throw. The verification is recommended to be done by utilizing the finite element method.

The (static) mechanical properties are to be determined as stipulated by the quality control procedures.

FIGURE 1
Specimen Locations in a Crank Throw (1 July 2018)

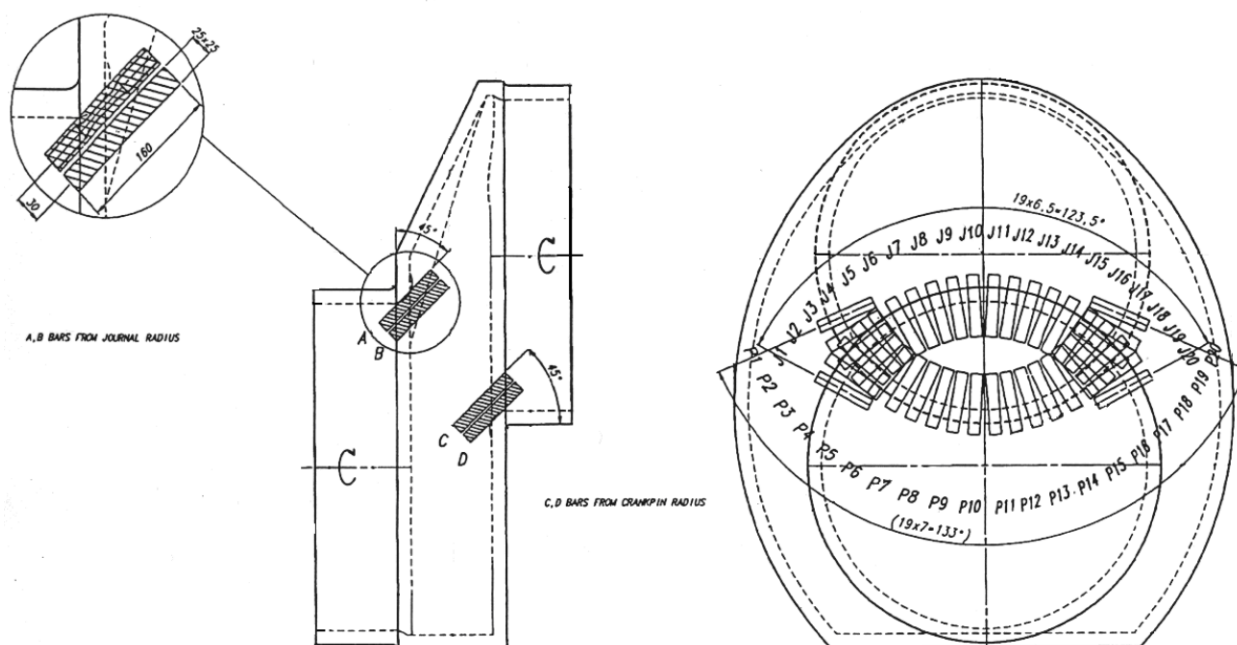

5.1 Determination of Bending Fatigue Strength

It is advisable to use un-notched specimens in order to avoid uncertainties related to the stress gradient influence. Push-pull testing method (stress ratio $R = -1$) is preferred, but especially for the purpose of critical plane criteria other stress ratios and methods may be added.

In order to ensure principal stress direction in push-pull testing to represent the full-size crank throw principal stress direction and when no further information is available, the specimen shall be taken in 45 degrees angle as shown in 4-2-1A8/Figure 1.

- i) If the objective of the testing is to document the influence of high cleanliness, test samples taken from positions approximately 120 degrees in a circumferential direction may be used. See 4-2-1A8/Figure 1.
- ii) If the objective of the testing is to document the influence of continuous grain flow (cgf) forging, the specimens should be restricted to the vicinity of the crank plane.

5.3 Determination of Torsional Fatigue Strength

- i) If the specimens are subjected to torsional testing, the selection of samples should follow the same guidelines as for bending above. The stress gradient influence has to be considered in the evaluation.
- ii) If the specimens are tested in push-pull and no further information is available, the samples should be taken out at an angle of 45 degrees to the crank plane in order to ensure collinearity of the principal stress direction between the specimen and the full-size crank throw. When taking the specimen at a distance from the (crank) middle plane of the crankshaft along the fillet, this plane rotates around the pin center point making it possible to resample the fracture direction due to torsion (the results are to be converted into the pertinent torsional values).

5.5 Other Test Positions

If the test purpose is to find fatigue properties and the crankshaft is forged in a manner likely to lead to cgf, the specimens may also be taken longitudinally from a prolonged shaft piece where specimens for mechanical testing are usually taken. The condition is that this prolonged shaft piece is heat treated as a part of the crankshaft and that the size is so as to result in a similar quenching rate as the crank throw.

When using test results from a prolonged shaft piece, it must be considered how well the grain flow in that shaft piece is representative for the crank fillets.

5.7 Correlation of Test Results

The fatigue strength achieved by specimen testing shall be converted to correspond to the full-size crankshaft fatigue strength with an appropriate method (size effect).

When using the bending fatigue properties from tests mentioned in this section, it should be kept in mind that successful continuous grain flow (cgf) forging leading to elevated values compared to other (non cgf) forging, will normally not lead to a torsional fatigue strength improvement of the same magnitude.

In such cases it is advised to either carry out also torsional testing or to make a conservative assessment of the torsional fatigue strength (e.g., by using no credit for cgf). This approach is applicable when using the Gough Pollard criterion. However, this approach is not recognized when using the von Mises or a multi-axial criterion such as Findley.

If the found ratio between bending and torsion fatigue differs significantly from $\sqrt{3}$, one should consider replacing the use of the von Mises criterion with the Gough Pollard criterion. Also, if critical plane criteria are used, it must be kept in mind that cgf makes the material inhomogeneous in terms of fatigue strength, meaning that the material parameters differ with the directions of the planes.

Any addition of influence factors must be made with caution. If for example a certain addition for clean steel is documented, it may not necessarily be fully combined with a K-factor for cgf. Direct testing of samples from a clean and cgf forged crank is preferred.

7 Full Size Testing

7.1 Hydraulic Pulsation

A hydraulic test rig can be arranged for testing a crankshaft in 3-point or 4-point bending as well as in torsion. This allows for testing with any R-ratio.

Although the applied load should be verified by strain gauge measurements on plain shaft sections for the initiation of the test, it is not necessarily used during the test for controlling load. It is also pertinent to check fillet stresses with strain gauge chains. Furthermore, it is important that the test rig provides boundary conditions as defined in 4-2-1A7/5.1 to 4-2-1A7/5.5.

The (static) mechanical properties are to be determined as stipulated by the quality control procedures.

7.3 Resonance Tester

A rig for bending fatigue normally works with an R-ratio of -1 . Due to operation close to resonance, the energy consumption is moderate. Moreover, the frequency is usually relatively high, meaning that 10^7 cycles can be reached within some days. 4-2-1A8/Figure 2 shows a layout of the testing arrangement.

The applied load should be verified by strain gauge measurements on plain shaft sections. It is also pertinent to check fillet stresses with strain gauge chains.

FIGURE 2
An Example of Testing Arrangement of the Resonance Tester
for Bending Loading (1 July 2018)

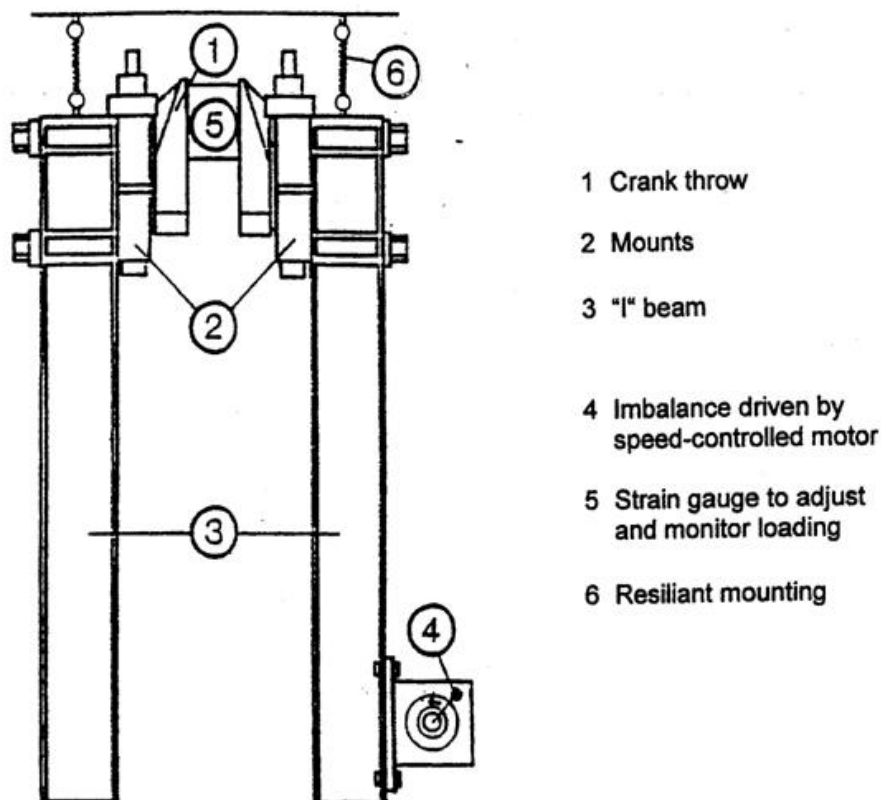

Clamping around the journals must be arranged in a way that prevents severe fretting which could lead to a failure under the edges of the clamps. If some distance between the clamps and the journal fillets is provided, the loading is consistent with 4-point bending and thus representative for the journal fillets also.

In an engine, the crankpin fillets normally operate with an R-ratio slightly above -1 and the journal fillets slightly below -1 . If found necessary, it is possible to introduce a mean load (deviate from $R = -1$) by means of a spring preload.

A rig for torsion fatigue can also be arranged as shown in 4-2-1A8/Figure 3. When a crank throw is subjected to torsion, the twist of the crankpin makes the journals move sideways. If one single crank throw is tested in a torsion resonance test rig, the journals with their clamped-on weights will vibrate heavily sideways.

This sideway movement of the clamped-on weights can be reduced by having two crank throws, especially if the cranks are almost in the same direction. However, the journal in the middle will move more.

FIGURE 3
An Example of Testing Arrangement of the Resonance Tester for Torsion Loading with Double Crank Throw Section (1 July 2018)

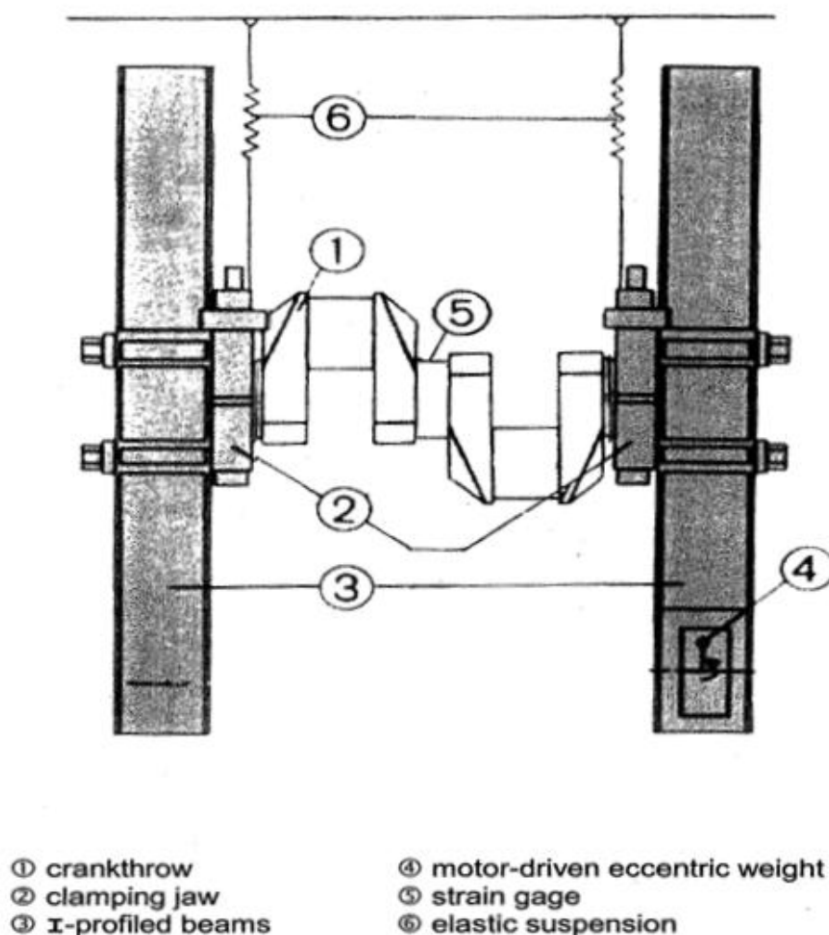

Since sideways movements can cause some bending stresses, the plain portions of the crankpins should also be provided with strain gauges arranged to measure any possible bending that could have an influence on the test results.

Similarly, to the bending case the applied load shall be verified by strain gauge measurements on plain shaft sections. It is also pertinent to check fillet stresses with strain gauge chains as well.

7.5 Use of Results and Crankshaft Acceptability

In order to combine tested bending and torsion fatigue strength results in calculation of crankshaft acceptability, see 4-2-1/5.9.8, the Gough-Pollard approach can be applied for the following cases:

Related to the crankpin diameter:

$$Q = \left(\sqrt{\left(\frac{\sigma_{BH}}{\sigma_{DWCT}} \right)^2 + \left(\frac{\tau_{BH}}{\tau_{DWCT}} \right)^2} \right)^{-1}$$

where

σ_{DWCT} = fatigue strength by bending testing

τ_{DWCT} = fatigue strength by torsion testing

Related to crankpin oil bore:

$$Q = \left(\sqrt{\left(\frac{\sigma_{BO}}{\sigma_{DWOT}} \right)^2 + \left(\frac{\tau_{TO}}{\tau_{DWOT}} \right)^2} \right)^{-1}$$

where

σ_{DWOT} = fatigue strength by bending testing

τ_{DWOT} = fatigue strength by torsion testing

Related to the journal diameter:

$$Q = \left(\sqrt{\left(\frac{\sigma_{BG}}{\sigma_{DWJT}} \right)^2 + \left(\frac{\tau_G}{\tau_{DWJT}} \right)^2} \right)^{-1}$$

where

σ_{DWJT} = fatigue strength by bending testing

τ_{DWJT} = fatigue strength by torsion testing

In case increase in fatigue strength due to the surface treatment is considered to be similar between the above cases, it is sufficient to test only the most critical location according to the calculation where the surface treatment had not been taken into account.

9 Use of Existing Results for Similar Crankshafts

For fillets or oil bores without surface treatment, the fatigue properties found by testing may be used for similar crankshaft designs providing:

i) Material:

- Similar material type
- Cleanliness on the same or better level
- The same mechanical properties can be granted (size versus hardenability)

ii) Geometry:

- Difference in the size effect of stress gradient is insignificant or it is considered
- Principal stress direction is equivalent. See 4-2-1A8/5.

iii) Manufacturing:

- Similar manufacturing process

Induction hardened or gas nitrided crankshafts will suffer fatigue either at the surface or at the transition to the core. The surface fatigue strength as determined by fatigue tests of full size cranks, may be used on an equal or similar design as the tested crankshaft when the fatigue initiation occurred at the surface. With the similar design, it is meant that a similar material type and surface hardness are used and the fillet radius and hardening depth are within approximately $\pm 30\%$ of the tested crankshaft.

Fatigue initiation in the transition zone can be either subsurface, i.e. below the hard layer, or at the surface where the hardening ends. The fatigue strength at the transition to the core can be determined by fatigue tests as described above, provided that the fatigue initiation occurred at the transition to the core. Tests made with the core material only will not be representative since the tension residual stresses at the transition are lacking.

Some recent research has shown that the fatigue limit can decrease in the very high cycle domain with subsurface crack initiation due to trapped hydrogen that accumulates through diffusion around some internal defect functioning as an initiation point. In these cases, it would be appropriate to reduce the fatigue limit by some percent per decade of cycles beyond 10^7 . Based on the publication “Metal Fatigue: Effects of Small Defects and Non-metallic Inclusions” the reduction is suggested to be 5% per decade especially when the hydrogen content is considered to be high.

11 Calculation Technique

11.1 Staircase Method

In the original staircase method, the first specimen is subjected to a stress corresponding to the expected average fatigue strength. If the specimen survives 10^7 cycles, it is discarded and the next specimen is subjected to a stress that is one increment above the previous (i.e., a survivor is always followed by the next using a stress one increment above the previous). The increment should be selected to correspond to the expected level of the standard deviation.

When a specimen fails prior to reaching 10^7 cycles, the obtained number of cycles is noted and the next specimen is subjected to a stress that is one increment below the previous. With this approach, the sum of failures and run-outs is equal to the number of specimens.

This original staircase method is only suitable when a high number of specimens are available. Through simulations it has been found that the use of about 25 specimens in a staircase test leads to a sufficient accuracy in the result.

11.3 Modified Staircase Method

When a limited number of specimens are available, it is advisable to apply the modified staircase method. Here the first specimen is subjected to a stress level that is most likely well below the average fatigue strength. When this specimen has survived 10^7 cycles, this same specimen is subjected to a stress level one increment above the previous. The increment should be selected to correspond to the expected level of the standard deviation. This is continued with the same specimen until failure.

Then the number of cycles is recorded and the next specimen is subjected to a stress that is at least 2 increments below the level where the previous specimen failed.

With this approach, the number of failures usually equals the number of specimens.

The number of run-outs, counted as the highest level where 10^7 cycles were reached, also equals the number of specimens.

The acquired result of a modified staircase method should be used with care, since some results available indicate that testing a runout on a higher test level, especially at high mean stresses, tends to increase the fatigue limit. However, this “training effect” is less pronounced for high strength steels (e.g., UTS > 800 MPa).

If the confidence calculation is desired or necessary, the minimum number of test specimens is 3.

11.5 Calculation of Sample Mean and Standard Deviation

A hypothetical example of tests for 5 crank throws is presented further in the subsequent text. When using the modified staircase method and the evaluation method of Dixon and Mood, the number of samples will be 10, meaning 5 run-outs and 5 failures, i.e.:

Number of samples: $n = 10$

Furthermore, the method distinguishes between:

Less frequent event is failures $C = 1$

Less frequent event is run-outs $C = 2$

The method uses only the less frequent occurrence in the test results, i.e. if there are more failures than run-outs, then the number of run-outs is used, and vice versa.

In the modified staircase method, the number of run-outs and failures are usually equal. However, the testing can be unsuccessful (e.g., the number of run-outs can be less than the number of failures if a specimen with 2 increments below the previous failure level goes directly to failure). On the other hand, if this unexpected premature failure occurs after a rather high number of cycles, it is possible to define the level below this as a run-out.

Dixon and Mood's approach, derived from the maximum likelihood theory, which also may be applied here, especially on tests with few samples, presented some simple approximate equations for calculating the sample mean and the standard deviation from the outcome of the staircase test. The sample mean can be calculated as follows:

$$\bar{S}_a = S_{a0} + d \cdot \left(\frac{A}{F} - \frac{1}{2} \right)$$

when $C = 1$

$$\bar{S}_a = S_{a0} + d \cdot \left(\frac{A}{F} + \frac{1}{2} \right)$$

when $C = 2$

The standard deviation can be found by:

$$s = 1.62 \cdot d \cdot \left(\frac{F \cdot B - A^2}{F^2} + 0.029 \right)$$

where

S_{a0} = lowest stress level for the less frequent occurrence

d = stress increment

F = $\sum f_i$

A = $\sum i \cdot f_i$

B = $\sum i^2 \cdot f_i$

i = stress level numbering

f_i = number of samples at stress level i

The formula for the standard deviation is an approximation and can be used when:

$$\frac{F \cdot B - A^2}{F^2} > 0.3 \text{ and } 0.5s < d < 1.5s$$

If any of these two conditions are not fulfilled, a new staircase test should be considered or the standard deviation should be taken quite large in order to be on the safe side.

If increment d is greatly higher than the standard deviation s , the procedure leads to a lower standard deviation and a slightly higher sample mean, both compared to values calculated

Respectively, if increment d is much less than the standard deviation s , the procedure leads to a higher standard deviation and a slightly lower sample mean.

11.7 Confidence Interval for Mean Fatigue Limit

If the staircase fatigue test is repeated, the sample mean and the standard deviation will most likely be different from the previous test. Therefore, it is necessary to assure with a given confidence that the repeated test values will be above the chosen fatigue limit by using a confidence interval for the sample mean.

The confidence interval for the sample mean value with unknown variance is known to be distributed according to the t -distribution (also called student's t -distribution) which is a distribution symmetric around the average.

The confidence level normally used for the sample mean is 90%, meaning that 90% of sample means from repeated tests will be above the value calculated with the chosen confidence level. 4-2-1A8/Figure 4 shows the t -value for $(1 - \alpha)$ 100% confidence interval for the sample mean.

FIGURE 4
Student's t -Distribution (1 July 2018)

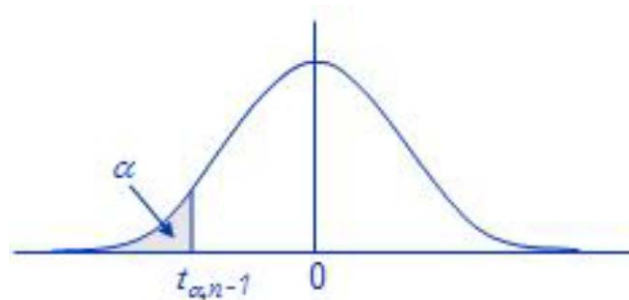

If S_a is the empirical mean and s is the empirical standard deviation over a series of n samples, in which the variable values are normally distributed with an unknown sample mean and unknown variance, the $(1 - \alpha)$ 100% confidence interval for the mean is:

$$P\left(S_a - t_{\alpha, n-1} \cdot \frac{s}{\sqrt{n}} < S_{aX\%}\right) = 1 - \alpha$$

The resulting confidence interval is symmetric around the empirical mean of the sample values, and the lower endpoint can be found as:

$$S_{aX\%} = S_a - t_{\alpha, n-1} \cdot \frac{s}{\sqrt{n}}$$

which is the mean fatigue limit (population value) to be used to obtain the reduced fatigue limit where the limits for the probability of failure are taken into consideration.

11.9 Confidence Interval for Standard Deviation

The confidence interval for the variance of a normal random variable is known to possess a chi-square distribution with $n - 1$ degrees of freedom.

The confidence level on the standard deviation is used to ensure that the standard deviations for repeated tests are below an upper limit obtained from the fatigue test standard deviation with a confidence level. 4-2-1A8/Figure 5 shows the chi-square for $(1 - \alpha)$ 100% confidence interval for the variance.

FIGURE 5
Chi-square Distribution (1 July 2018)

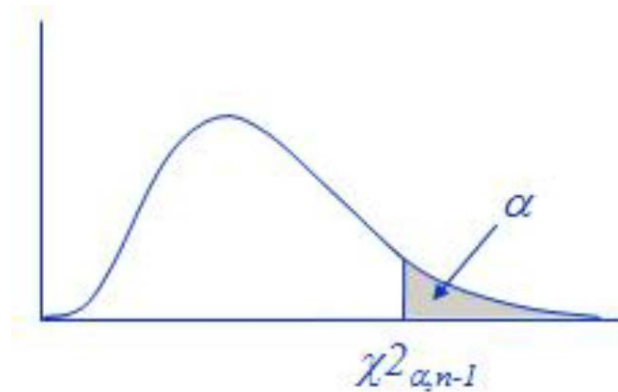

An assumed fatigue test value from n samples is a normal random variable with a variance of σ^2 and has an empirical variance s^2 . Then a $(1 - \alpha)$ 100% confidence interval for the variance is:

$$P\left(\frac{(n-1)s^2}{\sigma^2} < \chi^2_{\alpha, n-1}\right) = 1 - \alpha$$

A $(1 - \alpha)$ 100% confidence interval for the standard deviation is obtained by the square root of the upper limit of the confidence interval for the variance and can be found by:

$$S_{X\%} = \sqrt{\frac{n-1}{\chi^2_{\alpha, n-1}}} \cdot s$$

This standard deviation (population value) is to be used to obtain the fatigue limit, where the limits for the probability of failure are taken into consideration.

PART

4

CHAPTER 2 Prime Movers

SECTION 1 Appendix 9 – Guidance for Calculation of Surface Treated Fillets and Oil Bore Outlets (1 July 2018)

1 Introduction

This Appendix deals with surface treated fillets and oil bore outlets. The various treatments are explained and some empirical formulae are given for calculation purposes. Conservative empiricism has been applied intentionally, in order to be on the safe side from a calculation standpoint. Measurements should be used if available. In the case of a wide scatter (e.g., for residual stresses) the values should be chosen from the end of the range that would be on the safe side for calculation purposes.

3 Surface Treatment

“Surface treatment” is a term covering treatments such as thermal, chemical or mechanical operations, leading to inhomogeneous material properties – such as hardness, chemistry or residual stresses – from the surface to the core.

3.1 Surface Treatment Methods

The following list covers possible treatment methods and how they influence the properties that are decisive for the fatigue strength.

Surface Treatment Methods and the Characteristics They Affect

<i>Treatment Method</i>	<i>Affecting</i>
Induction hardening	Hardness and residual stresses
Nitriding	Chemistry, hardness and residual stresses
Case hardening	Chemistry, hardness and residual stresses
Die quenching (no temper)	Hardness and residual stresses
Cold rolling	Residual stresses
Stroke peening	Residual stresses
Shot peening	Residual stresses
Laser peening	Residual stresses
Ball coining	Residual stresses

It is important to note that since only induction hardening, nitriding, cold rolling and stroke peening are considered relevant for marine engines, other methods as well as combination of two or more of the above are not dealt with in this document. In addition, die quenching can be considered in the same way as induction hardening.

5 Calculation Principles

The basic principle is that the alternating working stresses shall be below the local fatigue strength (including the effect of surface treatment) wherein non-propagating cracks may occur, see also 4-2-1A9/11.1 for details. This is then divided by a certain safety factor. This applies through the entire fillet or oil bore contour as well as below the surface to a depth below the treatment-affected zone (i.e., to cover the depth all the way to the core).

Consideration of the local fatigue strength shall include the influence of the local hardness, residual stress and mean working stress. The influence of the “giga-cycle effect”, especially for initiation of subsurface cracks, should be covered by the choice of safety margin.

It is of vital importance that the extension of hardening/peening in an area with concentrated stresses be duly considered. Any transition where the hardening/peening is ended is likely to have considerable tensile residual stresses. This forms a ‘weak spot’ and is important if it coincides with an area of high stresses.

Alternating and mean working stresses must be known for the entire area of the stress concentration as well as to a depth of about 1.2 times the depth of the treatment. 4-2-1A9/Figure 1 indicates this principle in the case of induction hardening. The base axis is either the depth (perpendicular to the surface) or along the fillet contour.

FIGURE 1
Stresses as Functions of Depth, General Principles (1 July 2018)

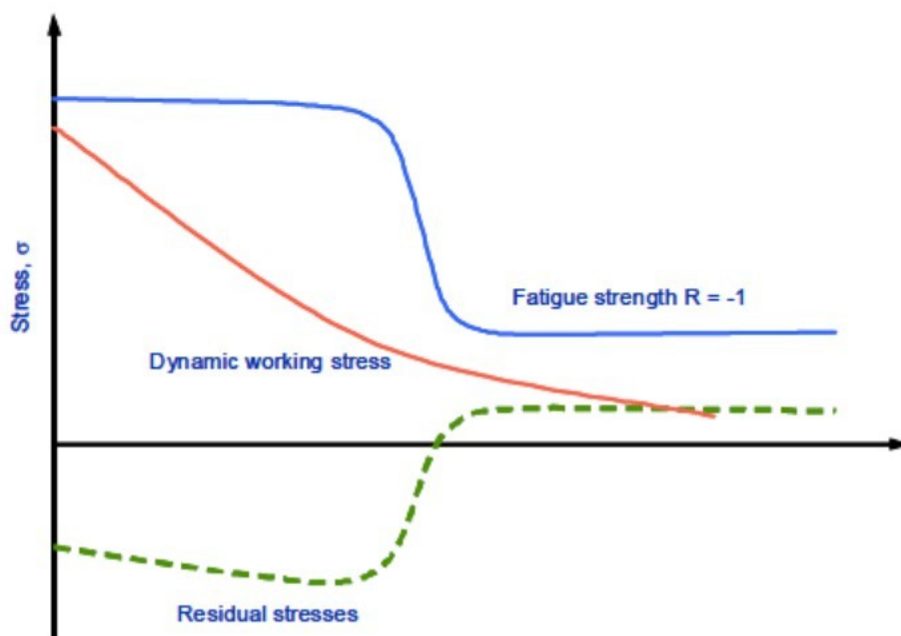

The acceptability criterion should be applied stepwise from the surface to the core as well as from the point of maximum stress concentration along the fillet surface contour to the web.

5.1 Evaluation of Local Fillet Stresses

It is necessary to have knowledge of the stresses along the fillet contour as well as in the subsurface to a depth somewhat beyond the hardened layer. Normally, this will be found via FEA as described in Appendix 4-2-1A7. However, the element size in the subsurface range will have to be the same size as at the surface. For crankpin hardening only the small element size will have to be continued along the surface to the hard layer.

If no FEA is available, a simplified approach may be used. This can be based on the empirically determined stress concentration factors (SCFs), as in 4-2-1/5.9.4 if within its validity range, and a relative stress gradient inversely proportional to the fillet radius. Bending and torsional stresses must be addressed separately. The combination of these is addressed by the acceptability criterion.

The subsurface transition-zone stresses, with the minimum hardening depth, can be determined by means of local stress concentration factors along an axis perpendicular to the fillet surface. These functions $\alpha_{B-local}$ and $\alpha_{T-local}$ have different shapes due to the different stress gradients.

The SCFs α_B and α_T are valid at the surface. The local $\alpha_{B-local}$ and $\alpha_{T-local}$ drop with increasing depth. The relative stress gradients at the surface depend on the kind of stress raiser, but for crankpin fillets they can be simplified to $2/R_H$ in bending and $1/R_H$ in torsion. The journal fillets are handled analogously by using R_G and D_G . The nominal stresses are assumed to be linear from the surface to a midpoint in the web between the crankpin fillet and the journal fillet for bending and to the crankpin or journal center for torsion.

The local SCFs are then functions of depth t according to the following formula as shown in 4-2-1A9/Figure 2 for bending:

$$\alpha_{B-local} = (\alpha_B - 1) \cdot e^{\frac{-2t}{R_H}} + 1 - \left(\frac{2 \cdot t}{\sqrt{W^2 + S^2}} \right)^{\frac{0.6}{\alpha_B}}$$

FIGURE 2
Bending SCF in the Crankpin Fillet as a Function of Depth (1 July 2018)

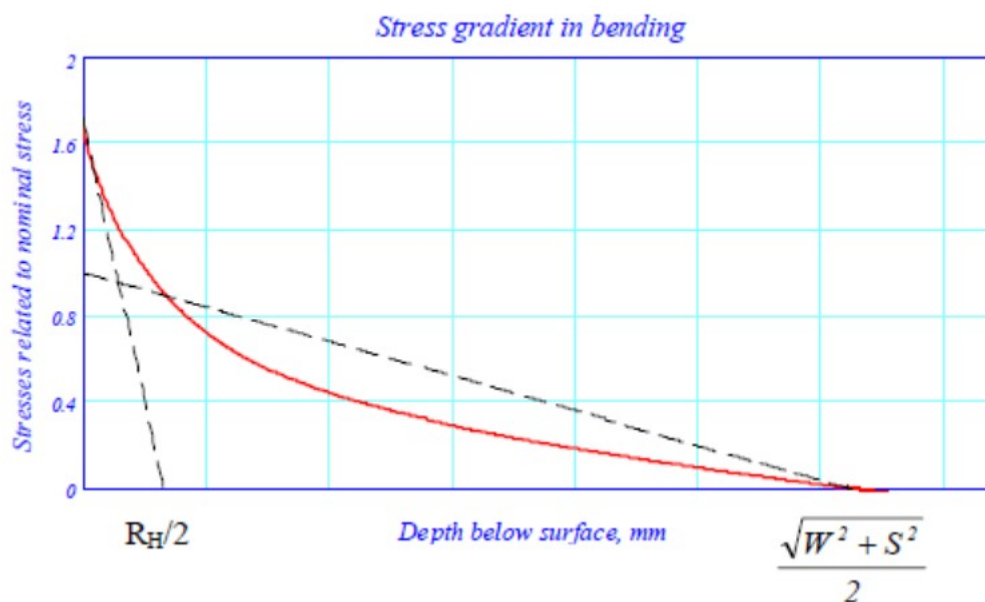

Note: The corresponding SCF for the journal fillet can be found by replacing R_H with R_G .

and respectively for torsion in the following formula and 4-2-1A9/Figure 3:

$$\alpha_{T-local} = (\alpha_T - 1) \cdot e^{\frac{-t}{R_H}} + 1 - \left(\frac{2 \cdot t}{D} \right)^{\frac{1}{\alpha_T}}$$

FIGURE 3
Torsional SCF in the Crankpin Fillet as a Function of Depth (1 July 2018)

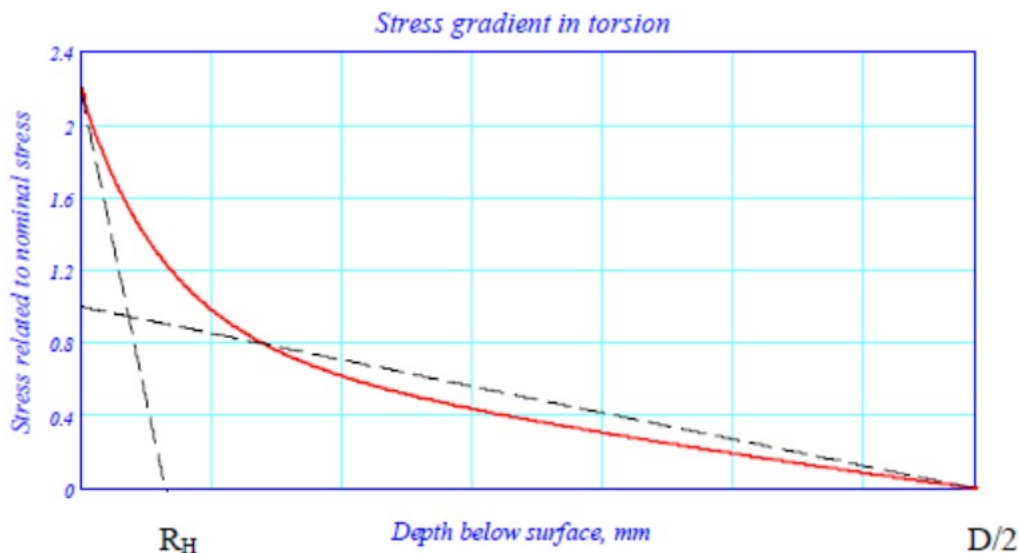

Note: The corresponding SCF for the journal fillet can be found by replacing R_H with R_G and D with D_G .

If the pin is hardened only and the end of the hardened zone is closer to the fillet than three times the maximum hardness depth, FEA should be used to determine the actual stresses in the transition zone.

5.3 Evaluation of Oil Bore Stresses

Stresses in the oil bores can be determined also by FEA. The element size should be less than $1/8$ of the oil bore diameter D_o and the element mesh quality criteria should be followed as prescribed in Appendix 4-2-1A7. The fine element mesh should continue well beyond a radial depth corresponding to the hardening depth.

The loads to be applied in the FEA are the torque – see Appendix 4-2-1A7/5.1 – and the bending moment, with four-point bending as in Appendix 4-2-1A7/5.3.

If no FEA is available, a simplified approach may be used. This can be based on the empirically determined SCF from 4-2-1/5.9.4 if within its applicability range. Bending and torsional stresses at the point of peak stresses are combined as in 4-2-1/5.9.6.

FIGURE 4
Stresses and Hardness in Induction Hardened Oil Holes (1 July 2018)

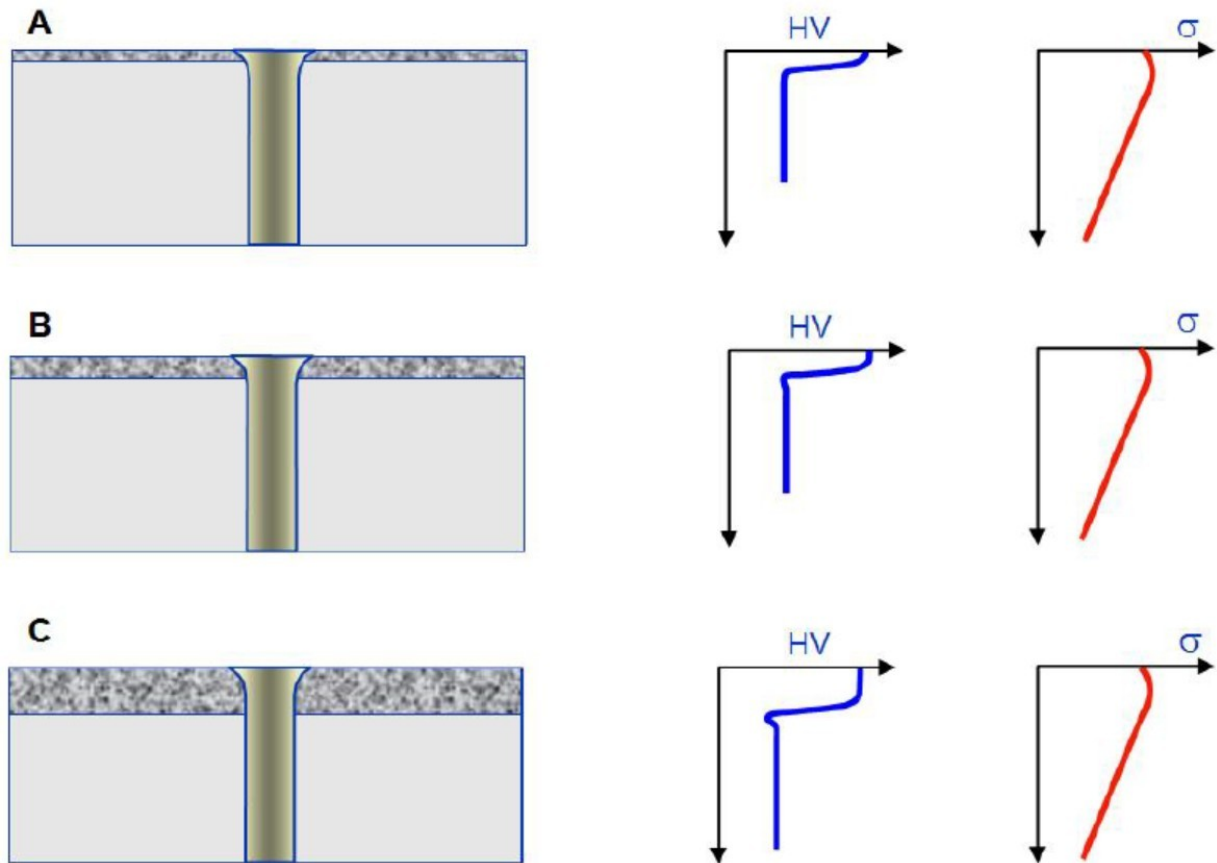

4-2-1A9/Figure 4 indicates a local drop of the hardness in the transition zone between a hard and soft material. Whether this drop occurs depends also on the tempering temperature after quenching in the QT process.

The peak stress in the bore occurs at the end of the edge rounding. Within this zone the stress drops almost linearly to the center of the pin. As can be seen from 4-2-1A9/Figure 4, for shallow (A) and intermediate (B) hardening, the transition point practically coincides with the point of maximal stresses. For deep hardening the transition point comes outside of the point of peak stress and the local stress can be assessed as a portion $(1 - 2t_H/D)$ of the peak stresses where t_H is the hardening depth.

The subsurface transition-zone stresses (using the minimum hardening depth) can be determined by means of local stress concentration factors along an axis perpendicular to the oil bore surface. These functions $\gamma_{B-local}$ and $\gamma_{T-local}$ have different shapes, because of the different stress gradients.

The stress concentration factors γ_B and γ_T are valid at the surface. The local SCFs $\gamma_{B-local}$ and $\gamma_{T-local}$ drop with increasing depth. The relative stress gradients at the surface depend on the kind of stress raiser, but for crankpin oil bores they can be simplified to $4/D_o$ in bending and $2/D_o$ in torsion. The local SCFs are then functions of the depth t :

$$\gamma_{B-local} = (\gamma_B - 1) \cdot e^{\frac{-4t}{D_o}} + 1$$

$$\gamma_{T-local} = (\gamma_T - 1) \cdot e^{\frac{-2t}{D_o}} + 1$$

5.5 Acceptability Criteria

Acceptance of crankshafts is based on fatigue considerations; 4-2-1/5.9.8 compares the equivalent alternating stress and the fatigue strength ratio to an acceptability factor of $Q \geq 1.15$ for oil bore outlets, crankpin fillets and journal fillets. This shall be extended to cover also surface treated areas independent of whether surface or transition zone is examined.

7 Induction Hardening

Generally, the hardness specification shall specify the surface hardness range (i.e., minimum and maximum values), the minimum and maximum extension in or through the fillet and also the minimum and maximum depth along the fillet contour. The referenced Vickers hardness is considered to be HV0.5 ~ HV5.

The induction hardening depth is defined as the depth where the hardness is 80% of the minimum specified surface hardness.

FIGURE 5
Typical Hardness as a Function of Depth (1 July 2018)

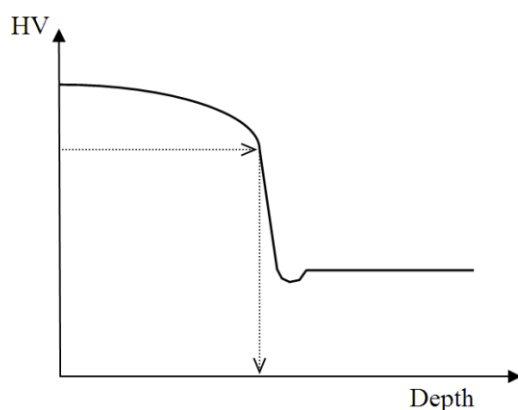

Note: The arrows indicate the defined hardening depth. Note the indicated potential hardness drop at the transition to the core. This can be a weak point as local strength may be reduced and tensile residual stresses may occur.

In the case of crankpin or journal hardening only, the minimum distance to the fillet shall be specified due to the tensile stress at the heat-affected zone as shown in 4-2-1A9/Figure 6.

FIGURE 6
Residual Stresses along the Surface of a Pin and Fillet (1 July 2018)

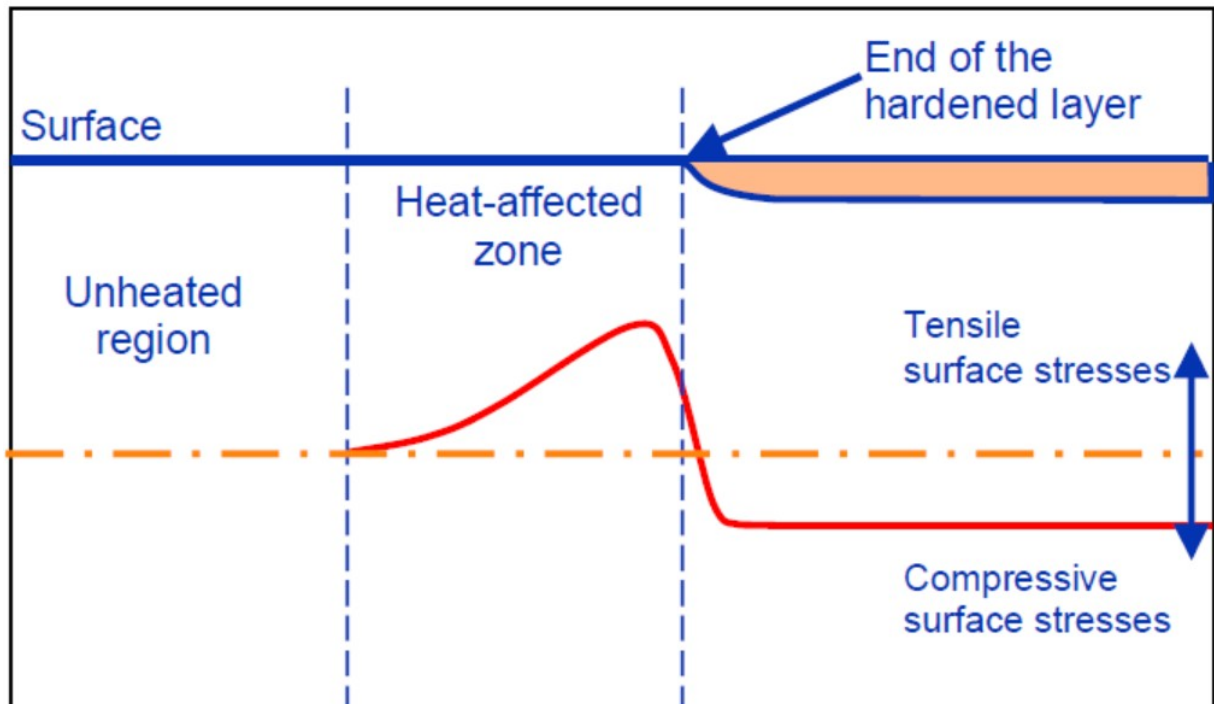

If the hardness-versus-depth profile and residual stresses are not known or specified, one may assume the following:

- i) The hardness profile consists of two layers (see 4-2-1A9/Figure 5):
 - Constant hardness from the surface to the transition zone
 - Constant hardness from the transition zone to the core material
- ii) Residual stresses in the hard zone of 200 MPa (compression)
- iii) Transition-zone hardness as 90% of the core hardness unless the local hardness drop is avoided
- iv) Transition-zone maximum residual stresses (von Mises) of 300 MPa tension

If the crankpin or journal hardening ends close to the fillet, the influence of tensile residual stresses has to be considered. If the minimum distance between the end of the hardening and the beginning of the fillet is more than 3 times the maximum hardening depth, the influence may be disregarded.

7.1 Local Fatigue Strength

Induction-hardened crankshafts will suffer fatigue either at the surface or at the transition to the core. The fatigue strengths, for both the surface and the transition zone, can be determined by fatigue testing of full size cranks as described in Appendix 4-2-1A8. In the case of a transition zone, the initiation of the fatigue can be either subsurface (i.e. below the hard layer) or at the surface where the hardening ends. Tests made with the core material only will not be representative since the tensile residual stresses at the transition are lacking.

Alternatively, the surface fatigue strength can be determined empirically as follows where HV is the surface Vickers hardness. The following formula provides a conservative value, with which the fatigue strength is assumed to include the influence of the residual stress. The resulting value is valid for a working stress ratio of $R = -1$:

$$\sigma_{F_{surface}} = 400 + 0.5 \cdot (HV - 400) \text{ MPa}$$

It has to be noted also that the mean stress influence of induction-hardened steels may be significantly higher than that for QT steels.

The fatigue strength in the transition zone, without taking into account any possible local hardness drop, shall be determined by the equation introduced in 4-2-1/5.9.7.

For journal and respectively to crankpin fillet applies:

$$\sigma_{F_{transition,cpin}} = \pm K \cdot (0.42 \cdot \sigma_B + 39.3) \cdot \left[0.264 + 1.073 \cdot Y^{-0.2} + \frac{785 - \sigma_B}{4900} + \frac{196}{\sigma_B} \cdot \sqrt{\frac{1}{X}} \right]$$

where

- Y = D_G for journal fillet
- = D for crankpin fillet
- = D for oil bore outlet
- X = R_G for journal fillet
- = R_H for crankpin fillet
- = D_o/2 for oil bore outlet

The influence of the residual stress is not included in the above formula.

For the purpose of considering subsurface fatigue, below the hard layer, the disadvantage of tensile residual stresses has to be considered by subtracting 20% from the value determined above. This 20% is based on the mean stress influence of alloyed quenched and tempered steel having a residual tensile stress of 300 MPa.

When the residual stresses are known to be lower, also smaller value of subtraction shall be used. For low-strength steels the percentage chosen should be higher.

For the purpose of considering surface fatigue near the end of the hardened zone (i.e., in the heat-affected zone shown in 4-2-1A9/Figure 6), the influence of the tensile residual stresses can be considered by subtracting a certain percentage, in accordance with 4-2-1A9/Table 1, from the value determined by the above formula.

TABLE 1

The Influence of Tensile Residual Stresses at a Given Distance from the End of the Hardening Towards the Fillet (1 July 2018)

<p>I. 0 to 1.0 of the max. hardening depth: 20%</p> <p>II. 1.0 to 2.0 of the max. hardening depth: 12%</p> <p>III. 2.0 to 3.0 of the max. hardening depth: 6%</p> <p>IV. 3.0 or more of the max. hardening depth: 0%</p>	
--	--

9 Nitriding

The hardness specification shall include the surface hardness range (min and max) and the minimum and maximum depth. Only gas nitriding is considered. The referenced Vickers hardness is considered to be HV0.5.

The depth of the hardening is defined in different ways in the various standards and the literature. The most practical method to use in this context is to define the nitriding depth t_N as the depth to a hardness of 50 HV above the core hardness.

The hardening profile should be specified all the way to the core. If this is not known, it may be determined empirically via the following formula:

$$HV(t) = HV_{core} + (HV_{surface} - HV_{core}) \cdot \left(\frac{50}{HV_{surface} - HV_{core}} \right)^{\left(\frac{t}{t_N} \right)^2}$$

where

- t = local depth
- $HV(t)$ = hardness at depth t
- HV_{core} = core hardness (minimum)
- $HV_{surface}$ = surface hardness (minimum)
- t_N = nitriding depth as defined above (minimum)

9.1 Local Fatigue Strength

It is important to note that in nitrided crankshaft cases, fatigue is found either at the surface or at the transition to the core. This means that the fatigue strength can be determined by tests as described in Appendix 4-2-1A8.

Alternatively, the surface fatigue strength (principal stress) can be determined empirically and conservatively as follows. This is valid for a surface hardness of 600 HV or greater:

$$\sigma_{F_{surface}} = 450 \text{ MPa}$$

Note that this fatigue strength is assumed to include the influence of the surface residual stress and applies for a working stress ratio of $R = -1$.

The fatigue strength in the transition zone can be determined by the equation introduced in 4-2-1/5.9.7. For crankpin and respectively to journal applies:

$$\sigma_{F_{transition,cpin}} = \pm K \cdot (0.42 \cdot \sigma_B + 39.3) \cdot \left[0.264 + 1.073 \cdot Y^{-0.2} + \frac{785 - \sigma_B}{4900} + \frac{196}{\sigma_B} \cdot \sqrt{\frac{1}{X}} \right]$$

where

- Y = D_G for journal fillet
- = D for crankpin fillet
- = D for oil bore outlet
- X = R_G for journal fillet
- = R_H for crankpin fillet
- = $D_o/2$ for oil bore outlet

Note that this fatigue strength is not assumed to include the influence of the residual stresses.

In contrast to induction-hardening the nitrided components have no such distinct transition to the core. Although the compressive residual stresses at the surface are high, the balancing tensile stresses in the core are moderate because of the shallow depth. For the purpose of analysis of subsurface fatigue the disadvantage of tensile residual stresses in and below the transition zone may be even disregarded in view of this smooth contour of a nitriding hardness profile.

Although in principle the calculation should be carried out along the entire hardness profile, it can be limited to a simplified approach of examining the surface and an artificial transition point. This artificial transition point can be taken at the depth where the local hardness is approximately 20 HV above the core hardness. In such a case, the properties of the core material should be used. This means that the stresses at the transition to the core can be found by using the local SCF formulae mentioned earlier when inserting $t = 1.2t_N$.

FIGURE 7
Sketch of the Location for the Artificial Transition Point
in the Depth Direction (1 July 2018)

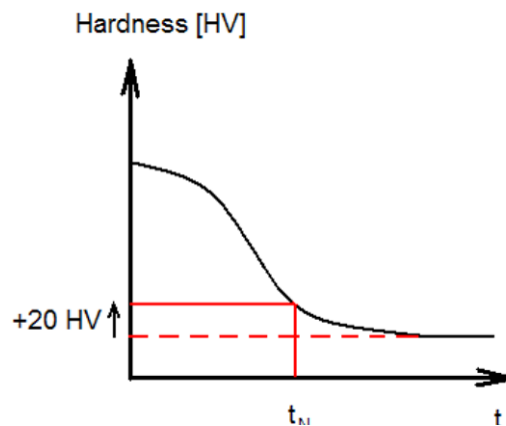

11 Cold Forming

The advantage of stroke peening or cold rolling of fillets is the compressive residual stresses introduced in the high-loaded area. Even though surface residual stresses can be determined by X-ray diffraction technique and subsurface residual stresses can be determined through neutron diffraction, the local fatigue strength is virtually non-assessable on that basis since suitable and reliable correlation formulae are hardly known.

Therefore, the fatigue strength has to be determined by fatigue testing; see also Appendix 4-2-1A8. Such testing is normally carried out as four-point bending, with a working stress ratio of $R = -1$. From these results, the bending fatigue strength – surface- or subsurface-initiated depending on the manner of failure – can be determined and expressed as the representative fatigue strength for applied bending in the fillet.

In comparison to bending, the torsion fatigue strength in the fillet may differ considerably from the ratio $\sqrt{3}$ (utilized by the von Mises criterion). The forming-affected depth that is sufficient to prevent subsurface fatigue in bending, may still allow subsurface fatigue in torsion. Another possible reason for the difference in bending and torsion could be the extension of the highly stressed area.

The results obtained in a full-size crank test can be applied for another crank size provided that the base material (alloyed Q+T) is of the similar type and that the forming is done so as to obtain the similar level of compressive residual stresses at the surface as well as through the depth. This means that both the extension and the depth of the cold forming must be proportional to the fillet radius.

11.1 Stroke Peening by Means of a Ball

The fatigue strength obtained can be documented by means of full size crank tests or by empirical methods if applied on the safe side. If both bending and torsion fatigue strengths have been investigated and differ from the ratio $\sqrt{3}$, the von Mises criterion should be excluded.

If only bending fatigue strength has been investigated, the torsional fatigue strength should be assessed conservatively. If the bending fatigue strength is concluded to be $x\%$ above the fatigue strength of the non-peened material, the torsional fatigue strength should not be assumed to be more than $2/3$ of $x\%$ above that of the non-peened material.

As a result of the stroke peening process the maximum of the compressive residual stress is found in the subsurface area. Therefore, depending on the fatigue testing load and the stress gradient, it is possible to have higher working stresses at the surface in comparison to the local fatigue strength of the surface. Because of this phenomenon small cracks may appear during the fatigue testing, which will not be able to propagate in further load cycles and/or with further slight increases of the testing load because of the profile of the compressive residual stress. Put simply, the high compressive residual stresses below the surface “arrest” small surface cracks.

This is illustrated in 4-2-1A9/Figure 8 as gradient load 2.

FIGURE 8
Working and Residual Stresses below the Stroke-peened Surface (1 July 2018)

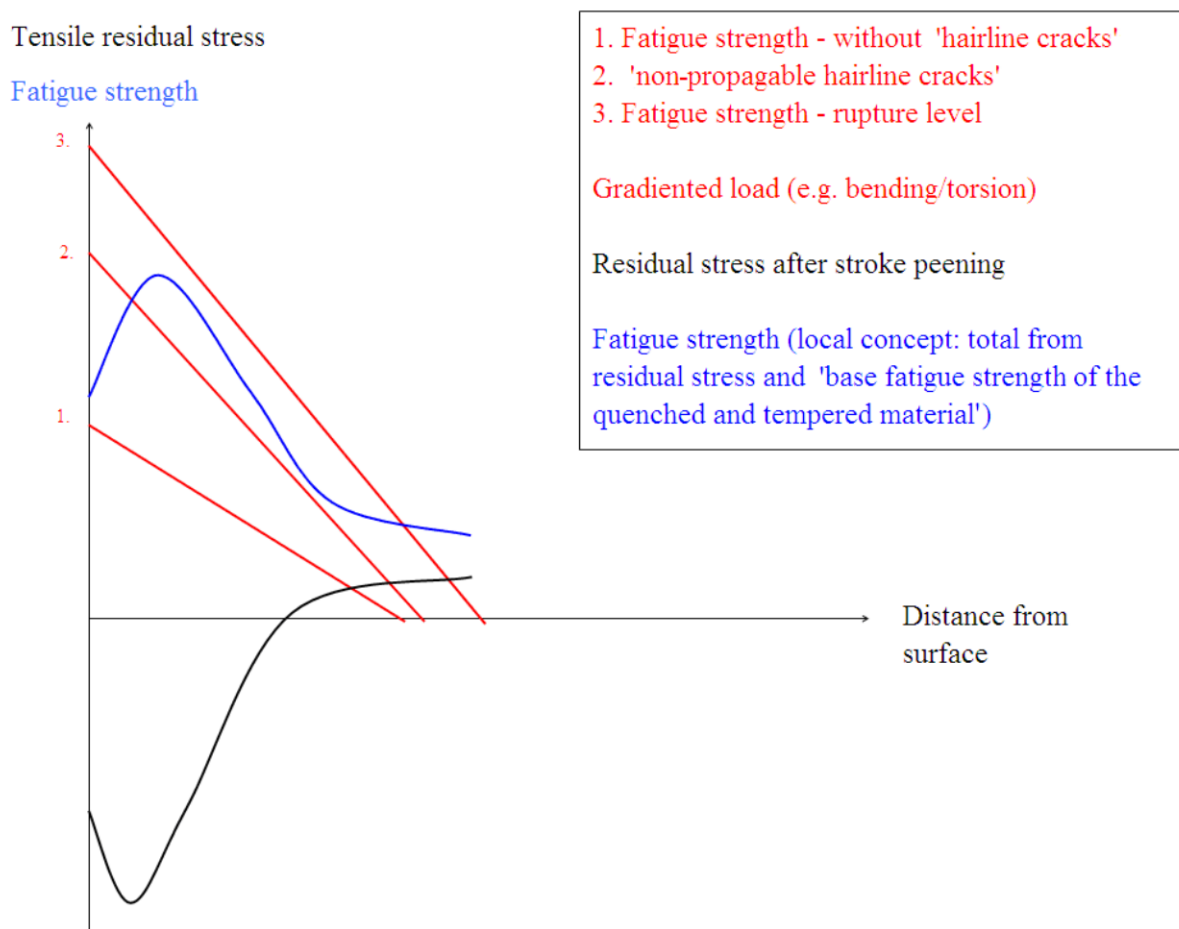

Note: Straight lines 1...3 represent different possible load stress gradients

In fatigue testing with full-size crankshafts these small “hairline cracks” should not be considered to be the failure crack. The crack that is technically the fatigue crack leading to failure, and that therefore shuts off the test-bench, should be considered for determination of the failure load level. This also applies if induction-hardened fillets are stroke-peened.

In order to improve the fatigue strength of induction-hardened fillets it is possible to apply the stroke peening process in the crankshafts’ fillets after they have been induction-hardened and tempered to the required surface hardness. If this is done, it might be necessary to adapt the stroke peening force to the hardness of the surface layer and not to the tensile strength of the base material. The effect on the fatigue strength of induction hardening and stroke peening the fillets shall be determined by a full-size crankshaft test.

11.1.1 Use of Existing Results for Similar Crankshafts

The increase in fatigue strength, which is achieved by applying stroke peening, may be utilized in another similar crankshaft if all of the following criteria are fulfilled:

- Ball size relative to fillet radius within $\pm 10\%$ in comparison to the tested crankshaft
- At least the same circumferential extension of the stroke peening

- Angular extension of the fillet contour relative to fillet radius within $\pm 15\%$ in comparison to the tested crankshaft and located to cover the stress concentration during engine operation
- Similar base material (e.g., alloyed quenched and tempered)
- Forward feed of ball of the same proportion of the radius
- Force applied to ball proportional to base material hardness (if different)
- Force applied to ball proportional to square of ball radius

11.3 Cold Rolling

The fatigue strength can be obtained by means of full size crank tests or by empirical methods, if these are applied so as to be on the safe side. If both, bending and torsion fatigue strengths have been investigated, and differ from the ratio $\sqrt{3}$, the von Mises criterion should be excluded.

If only bending fatigue strength has been investigated, the torsional fatigue strength should be assessed conservatively. If the bending fatigue strength is concluded to be $x\%$ above the fatigue strength of the non-rolled material, the torsional fatigue strength should not be assumed to be more than $2/3$ of $x\%$ above that of the non-rolled material.

11.3.1 Use of Existing Results for Similar Crankshafts

The increase in fatigue strength, which is achieved applying cold rolling, may be utilized in another similar crankshaft if all of the following criteria are fulfilled:

- At least the same circumferential extension of cold rolling
- Angular extension of the fillet contour relative to fillet radius within $\pm 15\%$ in comparison to the tested crankshaft and located to cover the stress concentration during engine operation
- Similar base material (e.g., alloyed quenched and tempered)
- Roller force to be calculated so as to achieve at least the same relative (to fillet radius) depth of treatment

PART

4

CHAPTER 2 Prime Movers

SECTION 1 Appendix 10 – Guidance for Calculation of Stress Concentration Factors in the Oil Bore Outlets of Crankshafts through Utilization of the Finite Element Method (1 July 2018)

1 General

The objective of the analysis described in this document is to substitute the analytical calculation of the stress concentration factor (SCF) at the oil bore outlet with suitable finite element method (FEM) calculated figures. The former method is based on empirical formulae developed from strain gauge readings or photo-elasticity measurements of various round bars. Because use of these formulae beyond any of the validity ranges can lead to erroneous results in either direction, the FEM-based method is highly recommended.

The SCF calculated according to the rules set forth in this document is defined as the ratio of FEM-calculated stresses to nominal stresses calculated analytically. In use in connection with the present method in 4-2-1/5.9.4, principal stresses shall be calculated.

The analysis is to be conducted as linear elastic FE analysis, and unit loads of appropriate magnitude are to be applied for all load cases.

It is advisable to check the element accuracy of the FE solver in use (e.g., by modeling a simple geometry and comparing the FEM-obtained stresses with the analytical solution).

A boundary element method (BEM) approach may be used instead of FEM.

3 Model Requirements

The basic recommendations and assumptions for building of the FE-model are presented in 4-2-1A10/3.1. The final FE-model must meet one of the criteria in 4-2-1A10/3.5.

3.1 Element Mesh Recommendations

For the mesh quality criteria to be met, construction of the FE model for the evaluation of stress concentration factors according to the following recommendations is advised:

- i)* The model consists of one complete crank, from the main bearing center line to the opposite side's main bearing center line.
- ii)* The following element types are used in the vicinity of the outlets:
 - 10-node tetrahedral elements
 - 8-node hexahedral elements
 - 20-node hexahedral elements
- iii)* The following mesh properties for the oil bore outlet are used:
 - Maximum element size $a = r/4$ through the entire outlet fillet as well as in the bore direction (if 8-node hexahedral elements are used, even smaller elements are required for meeting of the quality criterion)

- iv) Recommended manner for element size in the fillet depth direction
 - First layer's thickness equal to element size of a
 - Second layer's thickness equal to element size of $2a$
 - Third layer's thickness equal to element size of $3a$
- v) In general, the rest of the crank should be suitable for numeric stability of the solver
- vi) Drillings and holes for weight reduction have to be modelled
- vii) Submodeling may be used as long as the software requirements are fulfilled.

3.3 Material

4-2-1/5.9.4 does not consider material properties such as Young's modulus (E) and Poisson's ratio (ν). In the FE analysis, these material parameters are required, as primarily strain is calculated and stress is derived from strain through the use of Young's modulus and Poisson's ratio. Reliable values for material parameters have to be used, either as quoted in the literature or measured from representative material samples.

For steel, the following is advised: $E = 2.05 \times 10^5$ MPa and $\nu = 0.3$.

3.5 Element Mesh Quality Criteria

If the actual element mesh does not fulfil any of the following criteria in the area examined for SCF evaluation, a second calculation, with a finer mesh is to be performed.

3.5.1 Principal Stresses Criterion

The quality of the mesh should be verified through checking of the stress component normal to the surface of the oil bore outlet radius. With principal stresses σ_1 , σ_2 and σ_3 the following criterion is to be met:

$$\min (|\sigma_1|, |\sigma_2|, |\sigma_3|) < 0.03 \max (|\sigma_1|, |\sigma_2|, |\sigma_3|)$$

3.5.2 Averaged/Unaveraged Stresses Criterion

The criterion is based on observation of the discontinuity of stress results over elements at the fillet for the calculation of the SCF:

- Unaveraged nodal stress results calculated from each element connected to a node i should differ less than 5 % from the 100 % averaged nodal stress results at this node i at the location examined.

5 Load Cases and Assessment of Stress

For substitution of the analytically determined SCF in 4-2-1/5.9.4, the following load cases are to be calculated.

5.1 Torsion

The structure is loaded in pure torsion. The surface warp at the end faces of the model is suppressed.

Torque is applied to the central node, on the crankshaft axis. This node acts as the master node with six degrees of freedom, and is connected rigidly to all nodes of the end face.

The boundary and load conditions as shown in 4-2-1A10/Figure 1 are valid for both in-line- and V- type engines.

FIGURE 1
Boundary and Load Conditions for the Torsion Load Case (1 July 2018)

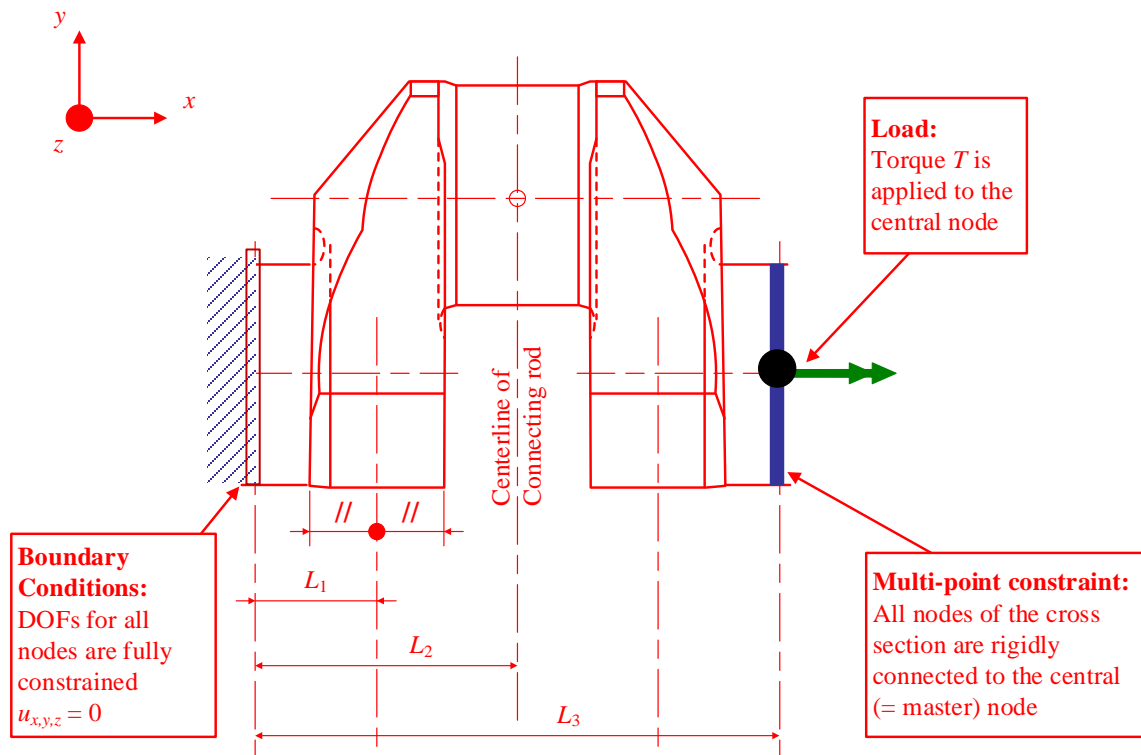

For all nodes in an oil bore outlet, the principal stresses are obtained and the maximum value is taken for subsequent calculation of the SCF:

$$\gamma_T = \frac{\max(|\sigma_1|, |\sigma_2|, |\sigma_3|)}{\tau_N}$$

where the nominal torsion stress τ_N referred to the crankpin is evaluated per 4-2-1/5.9.3(b) with torque T :

$$\tau_N = \frac{T}{W_P}$$

5.3 Bending

The structure is loaded in pure bending. The surface warp at the end faces of the model is suppressed.

The bending moment is applied to the central node on the crankshaft axis. This node acts as the master node, with six degrees of freedom, and is connected rigidly to all nodes of the end face.

The boundary and load conditions as shown in 4-2-1A10/Figure 2 are valid for both in-line- and V- type engines.

FIGURE 2
Boundary and Load Conditions for the Pure Bending Load Case (1 July 2018)

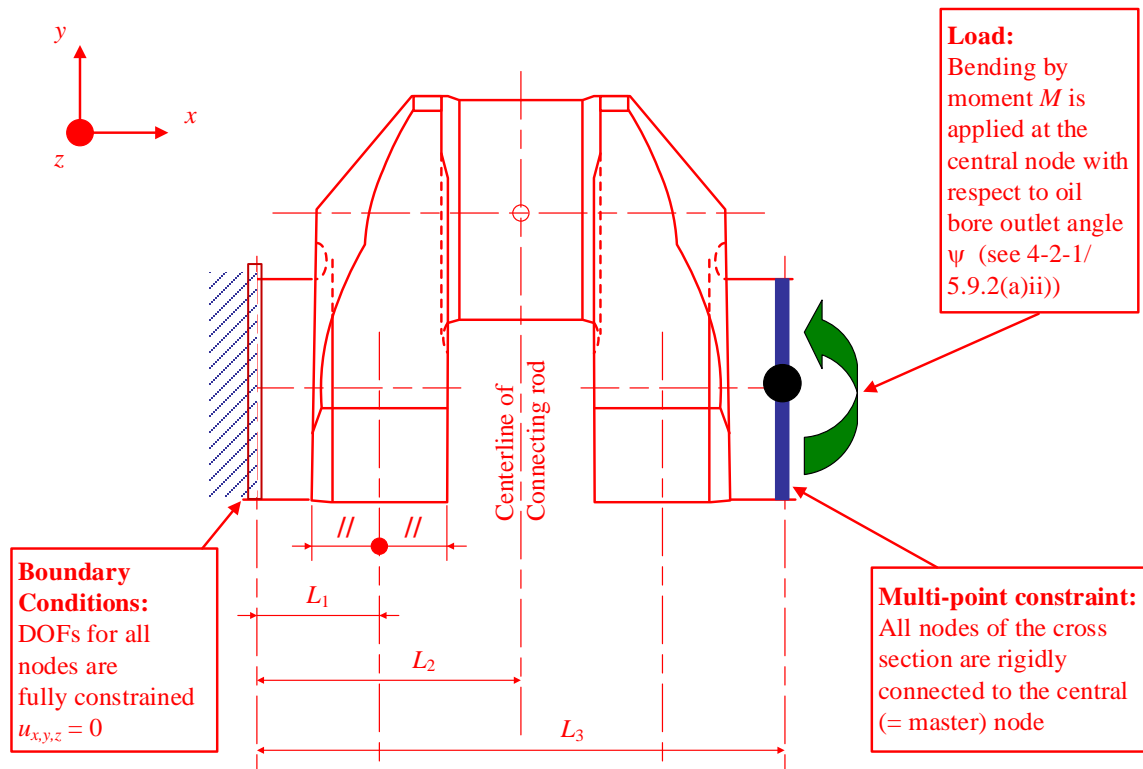

For all nodes in the oil bore outlet, principal stresses are obtained and the maximum value is taken for subsequent calculation of the SCF:

$$\gamma_B = \frac{\max(|\sigma_1|, |\sigma_2|, |\sigma_3|)}{\sigma_N}$$

where the nominal bending stress σ_N referred to the crankpin is calculated per 4-2-1/5.9.2(b)ii) with bending moment M :

$$\sigma_N = \frac{M}{W_e}$$

PART

4

CHAPTER 2 Prime Movers

SECTION 2 Turbochargers

1 General

1.1 Application

Turbochargers for diesel engines rated 100 kW (135 hp) and over, intended for propulsion and for auxiliary services essential for propulsion, maneuvering and safety of the vessel [see 4-1-1/1.3.2(a)], are to be designed, constructed, tested, certified and installed in accordance with the requirements of this section.

Turbochargers are to be type approved, either separately or as a part of an engine.

Turbochargers for diesel engines rated less than 100 kW (135 hp) are to be designed, constructed and equipped in accordance with good commercial and marine practice. Acceptance of such turbochargers will be based on the manufacturer's affidavit, verification of turbocharger nameplate data and subject to a satisfactory performance test after installation, conducted in the presence of the Surveyor.

1.3 Definitions

1.3.1 Turbocharger

The term *Turbocharger* used in this section refers to any equipment that is exhaust gas or mechanically driven by the engine, such as exhaust turbochargers or superchargers, which is designed to charge the diesel engine cylinders with air at a higher pressure and hence higher density than air at atmospheric pressure.

Turbochargers are categorized in three groups depending on served power by cylinder groups (that is, the total power of the cylinders served by each turbocharger):

- Category A: ≤ 1000 kW
- Category B: > 1000 kW and ≤ 2500 kW
- Category C: > 2500 kW

1.3.2 Maximum Operating Speed

The *Maximum Operating Speed* is the maximum permissible speed for which the turbocharger is designed to run continuously at the maximum permissible operating temperature. This speed is to be used for making strength calculations.

1.3.3 Generic Range

A *Generic Range* means a series of turbochargers which are of the same design, but scaled to each other.

1.5 Plans and Particulars to be Submitted

1.5.1 Turbocharger Construction

- i) Turbochargers of category A
 - Containment test report
 - Cross sectional drawing with principal dimensions and names of components
 - Test program

- ii) Turbochargers of categories B and C
 - Cross sectional drawing with principal dimensions and materials of housing components for containment evaluation
 - Documentation of containment in the event of disc fracture
 - Maximum permissible operating speed (rpm)
 - Alarm level for over-speed
 - Maximum permissible exhaust gas temperature before turbine
 - Alarm level for exhaust gas temperature before turbine
 - Minimum lubrication oil inlet pressure
 - Lubrication oil inlet pressure low alarm set point
 - Maximum lubrication oil outlet temperature
 - Lubrication oil outlet temperature high alarm set point
 - Maximum permissible vibration levels (i.e., self- and externally generated vibration).
 - Arrangement of lubrication system, all variants within a range
 - Type test reports, including containment test report
 - Test program
- iii) Turbochargers of category C
 - Drawings of the housing and rotating parts including details of blade fixing
 - Material specifications (chemical composition and mechanical properties) of all parts mentioned above
 - Welding details and welding procedure of above mentioned parts, if applicable
 - Documentation of safe torque transmission when the disc is connected to the shaft by an interference fit (applicable to two sizes in a generic range of turbochargers)
 - Information on expected lifespan, considering creep, low cycle fatigue and high cycle fatigue
 - Operation and maintenance manuals (applicable to two sizes in a generic range of turbochargers)

3 Materials

3.1 Material Specifications and Purchase Orders

Materials entered into the construction of turbochargers are to conform to specifications approved in connection with the design in each case. Copies of material specifications and purchase orders are to be submitted to the Surveyor for information and verification.

3.3 Category A and B Turbochargers

Materials for category A and B turbochargers need not be verified by a Surveyor. The turbocharger manufacturer is to assure itself of the quality of the materials.

3.5 Category C Turbochargers

The materials are to meet specifications in Part 2, Chapter 3 or that approved in connection with the design. Except as noted in 4-2-2/3.7, materials for category C turbochargers, as specified below, are to be tested in the presence of and inspected by the Surveyor.

- i) Forgings: compressor and turbine rotors and shafts.
- ii) Blade material.

3.7 Alternative Material Test Requirements

3.7.1 Alternative Specifications

Material manufactured to specifications other than those given in Part 2, Chapter 3 may be accepted, provided that such specifications are approved in connection with the design and that they are verified or tested by a Surveyor as complying with the specifications.

3.7.2 Steel-bar Stock

Hot-rolled steel bars up to 305 mm (12 in.) in diameter may be used when approved for use in place of any of the forgings as per 4-2-2/3.5i) above, under the conditions outlined in Section 2-3-8.

3.7.3 Certification Under Quality Assurance Assessment PQA (IACS UR Z26 Alternative Certification Scheme)

For turbochargers certified under quality assurance assessment PQA (ACS) as provided for in 4-2-2/11.3.2(b), material tests and inspections required by 4-2-2/3 need not be witnessed by the Surveyor. Such tests are to be conducted by the turbocharger manufacturer whose certified material test reports will be accepted instead.

5 Design Requirements and Corresponding Type Testing

5.1 General

The turbochargers are to be designed to operate under conditions given in 4-1-1/Tables 7 and 8. The component lifetime and the alarm level for speed are to be based on 45°C air inlet temperature.

5.3 Containment

Turbochargers are to fulfill containment in the event of a rotor burst. This means that at a rotor burst no part may penetrate the casing of the turbocharger or escape through the air intake. For documentation purposes (test/calculation), it shall be assumed that the discs disintegrate in the worst possible way.

Turbocharger containment is to be documented by testing. For category C turbochargers, the testing is to be witnessed by the Surveyor. Fulfillment of this requirement can be awarded to a generic range of turbochargers based on testing of one specific unit. Testing of a large unit is preferred as this is considered conservative for all smaller units in the generic range. In any case, it is to be documented (e.g., by calculation) that the selected test unit really is representative for the whole generic range.

The minimum test speeds, relative to the maximum permissible operating speed, are:

- For the compressor: 120%
- For the turbine: 140% or the natural burst speed, whichever is lower

Containment tests are to be performed at working temperature.

A numerical analysis (simulation) of sufficient containment integrity of the casing based on calculations by means of a simulation model may be accepted in lieu of the practical containment test, provided that:

- i) The numerical simulation model has been tested and its suitability/accuracy has been proven by direct comparison between calculation results and the practical containment test for a reference application (reference containment test). This test is to be performed at least once by the manufacturer for acceptance of the numerical simulation method in lieu of tests.
- ii) The corresponding numerical simulation for the containment is performed for the same speeds as specified for the containment test.
- iii) Material properties for high-speed deformations are to be applied in the numeric simulation. The correlation between normal properties and the properties at the pertinent deformation speed are to be substantiated.
- iv) The design of the turbocharger regarding geometry and kinematics is similar to the turbocharger that was used for the reference containment test. In general, totally new designs will call for a new reference containment test.

5.5 Disc-shaft Shrinkage Fit (applicable to turbochargers of category C)

In cases where the disc is connected to the shaft with interference fit, calculations are to substantiate safe torque transmission during all relevant operating conditions such as maximum speed, maximum torque and maximum temperature gradient combined with minimum shrinkage amount.

5.7 Type Testing (applicable to category B and C turbochargers)

- i) The type test for a generic range of turbochargers may be carried out either on an engine (for which the turbocharger is foreseen) or in a test rig.
- ii) Turbochargers are to be subjected to at least 500 load cycles at the limits of operation. This test may be waived if the turbocharger together with the engine is subjected to this kind of low cycle testing.
 The suitability of the turbocharger for such kind of operation is to be preliminarily stated by the manufacturer.
- iii) The rotor vibration characteristics are to be measured and recorded in order to identify possible sub-synchronous vibrations and resonances.
- iv) The type test is to be completed by a hot running test at maximum permissible speed combined with maximum permissible temperature for at least one hour. After this test, the turbocharger is to be opened for examination, with focus on possible rubbing and the bearing conditions.
- v) The type test program is to be submitted and approved. The extent of the Surveyor's presence during the various parts of the type tests is to be agreed before commencement of the tests. For category C turbochargers, the testing detailed under 4-2-2/5.7iv) is to be witnessed by the Surveyor.

7 Piping Systems for Turbochargers

The lubricating oil and cooling water piping systems of turbochargers are to be in accordance with the provisions of 4-6-5/5 and 4-6-5/7, respectively.

8 Alarms and Monitoring

For category B and C turbochargers, indications and alarms as listed below are required. Indications may be provided at either local or remote locations.

Monitored Parameters	Turbochargers category B		Turbochargers category C		Notes
	Alarm (High) ⁽⁴⁾	Indication ⁽⁴⁾	Alarm (High) ⁽⁴⁾	Indication ⁽⁴⁾	
Speed	Alarm (High) ⁽⁴⁾	Indication ⁽⁴⁾	Alarm (High) ⁽⁴⁾	Indication ⁽⁴⁾	
Exhaust gas at each turbocharger inlet, temperature	Alarm (High) ⁽¹⁾	Indication ⁽¹⁾	Alarm (High)	Indication	High temp. alarms for each cylinder at engine is acceptable ⁽²⁾
Lub. oil at turbocharger outlet, temperature			Alarm (High)	Indication	If not forced system, oil temperature near bearings
Lub. oil at turbocharger inlet, pressure	Alarm (Low)	Indication	Alarm (Low)	Indication	Only for forced lubrication systems ⁽³⁾

Notes:

- 1 For category B turbochargers, the exhaust gas temperature may be alternatively monitored at the turbocharger outlet, provided that the alarm level is set to a safe level for the turbine and that correlation between inlet and outlet temperatures is substantiated.
- 2 Alarm and indication of the exhaust gas temperature at turbocharger inlet may be waived if alarm and indication for individual exhaust gas temperature is provided for each cylinder and the alarm level is set to a value safe for the turbocharger.
- 3 Separate sensors are to be provided if the lubrication oil system of the turbocharger is not integrated with the lubrication oil system of the diesel engine or if it is separated by a throttle or pressure reduction valve from the diesel engine lubrication oil system.
- 4 On turbocharging systems where turbochargers are activated sequentially, speed monitoring is not required for the turbocharger(s) being activated last in the sequence, provided all turbochargers share the same intake air filter and they are not fitted with waste gates.

For vessels with **ACC** or **ACCU** notation, see Section 4-9-5 or 4-9-6, as applicable.

9 Installation of Turbochargers

9.1 Air Inlet

The air inlet of the turbocharger is to be fitted with a filter to minimize the entrance of harmful foreign material or water.

9.3 Hot Surfaces

Hot surfaces likely to come into contact with the crew are to be water-jacketed or effectively insulated. Where the temperature of hot surfaces is likely to exceed 220°C (428°F) and where any leakage, under pressure or otherwise, of fuel oil, lubricating oil or other flammable liquid is likely to come into contact with such surfaces, they are to be suitably insulated with non-combustible materials that are impervious to such liquid. Insulation material not impervious to oil is to be encased in sheet metal or an equivalent impervious sheath.

9.5 Pipe and Duct Connections

Pipe or duct connections to the turbocharger casing are to be made in such a way as to prevent the transmission of excessive loads or moments to the turbochargers.

11 Testing, Inspection and Certification of Turbochargers

11.1 Shop Inspection and Tests

The following shop inspection and tests are to be witnessed by a Surveyor for category C turbochargers.

11.1.1 Material Tests

Materials entered into the construction of turbines are to be tested in the presence of a Surveyor in accordance with the provisions of 4-2-2/3.

11.1.2 Welded Fabrication

All welded fabrication is to be conducted with qualified welding procedures, by qualified welders, and with welding consumables acceptable to the Surveyors. See Section 2-4-2.

11.1.3 Hydrostatic Tests

The cooling spaces of each gas inlet and outlet casing are to be hydrostatically tested to 1.5 times the working pressure but not to be less than 4 bar.

11.1.4 Dynamic Balancing

Rotors are to be dynamically balanced at a speed equal to the natural period of the balancing machine and rotor combined.

11.1.5 Shop Trial

Upon completion of fabrication and assembly, each turbocharger is to be subjected to a shop trial, either on a test bed or on a test engine, in accordance with the manufacturer's test schedule, which is to be submitted for review before the trial. During the trial, the following tests are to be conducted:

i) Compressor wheels are to be overspeed tested for 3 minutes on a test bed at 20% above the maximum operating speed at ambient temperature, or 10% above maximum operating speed at 45°C inlet temperature when tested in the actual housing with the corresponding pressure ratio.

The overspeed test may be waived for forged wheels that are individually controlled by an approved nondestructive method.

ii) A mechanical running test for at least 20 minutes at maximum operating speed and operating temperature, or a test run on the engine for which the turbocharger is intended for 20 minutes at 110% of the engine's rated output.

11.3 Certification of Turbochargers

11.3.1 General

Each turbocharger required to be certified by 4-2-2/1.1 is:

- i) To have its design approved by ABS; for which purpose, plans and data as required by 4-2-2/1.5 are to be submitted to ABS for approval, showing compliance with the requirements of this Section. A unit of the same type is to be satisfactorily containment and type tested, as required by 4-2-2/5.3 and 4-2-2/5.7.
- ii) Turbochargers of category C are to be surveyed during their construction for compliance with the design approved, along with, but not limited to, material tests, hydrostatic tests, dynamic balancing, performance tests, etc., as indicated in 4-2-2/11.1, all to be carried out to the satisfaction of the Surveyor.
- iii) Each turbocharger required to be certified by 4-2-2/1.1 is to be delivered with certificates indicating compliance with the requirements of this section and the applicable type approval.

11.3.2 Approval Under the Type Approval Program

11.3.2(a) Product Design Assessment. Upon application by the manufacturer, each model of a type of turbocharger is to be design assessed as described in 1-1-A3/5.1. For this purpose, each design of a turbocharger type is to be approved in accordance with 4-2-2/11.3.1i). Turbochargers so approved may be applied to ABS for listing on the ABS website as Products Design Assessed. Once listed, and subject to renewal and updating of the certificate as required by 1-1-A3/5.7, turbocharger particulars will not be required to be submitted to ABS each time the turbocharger is proposed for use on board a vessel.

11.3.2(b) Manufacturing Assessment for Turbochargers. A manufacturer of turbochargers, who operates a quality assurance system in the manufacturing facilities, may apply to ABS for quality assurance assessment described in 1-1-A3/5.3.1(a) (Manufacturers Procedure), 1-1-A3/5.3.1(b) (RQS) or 1-1-A3/5.5 (PQA (IACS UR Z26 Alternative Certification Scheme)).

Upon satisfactory assessment under 1-1-A3/5.5 (PQA), turbochargers produced in those facilities will not require a Surveyor's attendance at the tests and inspections indicated in 4-2-2/11.3.1ii). Such tests and inspections are to be carried out by the manufacturer whose quality control documents will be accepted. Certification of each turbocharger will be based on verification of approval of the design and on continued effectiveness of the quality assurance system. See 1-1-A3/5.7.1(a).

Audits under PQA are to include:

- Chemical composition of material for the rotating parts
- Mechanical properties of the material of a representative specimen for the rotating parts and the casing
- UT and crack detection of rotating parts
- Dimensional inspection of rotating parts
- Rotor balancing
- Hydrostatic pressure testing
- Overspeed testing.

11.3.2(c) Type Approval Program. Turbocharger types which have their designs approved in accordance with 4-2-2/11.3.2(a) and the quality assurance system of their manufacturing facilities approved in accordance with 4-2-2/11.3.2(b) will be deemed Type Approved and will be eligible for listing on the ABS website as Type Approved Product.

11.5 Engine and Shipboard Trials

Before final acceptance, each turbocharger, after installation on the engine, is to be operated in the presence of the Surveyor to demonstrate its ability to function satisfactorily under operating conditions and its freedom from harmful vibrations at speeds within the operating range. The test schedules are to be as indicated in 4-2-1/13.9 for engine shop test and in 4-2-1/15 for shipboard trial.

13 Spare Parts

While spare parts are not required for purposes of classification, the spare parts listed in Appendix 4-2-1A4 are provided as a guidance for vessels intended for unrestricted service. The maintenance of spare parts aboard each vessel is the responsibility of the owner.

PART

4

CHAPTER 2 Prime Movers

SECTION 3 Gas Turbines

1 General

1.1 Application

Gas turbines having a rated power of 100 kW (135 hp) and over, intended for propulsion and for auxiliary services essential for propulsion, maneuvering and safety (see 4-1-1/1.3) of the vessel, are to be designed, constructed, tested, certified and installed in accordance with the requirements of this section.

Gas turbines having a rated power of less than 100 kW (135 hp) are not required to comply with the provision of this section but are to be designed, constructed and equipped in accordance with good commercial and marine practice. Acceptance of the gas turbines will be based on the manufacturer's affidavit, verification of gas turbines nameplate data and subject to a satisfactory performance test after installation conducted in the presence of the Surveyor.

Gas turbines having a rated power of 100 kW (135 hp) and over, intended for services considered not essential for propulsion, maneuvering and safety, are not required to be designed, constructed and certified by ABS in accordance with the provisions of this section. They are to comply with safety features, such as overspeed protection, etc., as provided in 4-2-3/7 hereunder, as applicable, and are subject to a satisfactory performance test after installation, conducted in the presence of the Surveyor.

Provisions for piping systems of gas turbines, in particular, fuel oil, lubricating oil, cooling water and exhaust gas systems, are addressed in Section 4-6-5.

1.3 Definitions

1.3.1 Rated Power

The *Rated Power* is the maximum power output at which the turbine is designed to run continuously at its rated speed. Gas turbine power is to be that developed at the lowest expected inlet air temperature, but in no case is this design inlet air temperature to exceed 15°C (59°F).

1.5 Plans and Particulars to be Submitted

1.5.1 Gas Turbine Construction

Sectional assembly

Casings

Foundation and fastening

Combustion chambers

Gasifiers

Regenerators or recuperators

Turbine rotors

Compressor rotors

- Compressor and turbine discs
- Blading
- Shafts
- Bearing arrangements
- Thrust bearing
- 1.5.2 Gas Turbine Systems and Appurtenances
 - Couplings
 - Clutches
 - Starting arrangements
 - Fuel oil system
 - Shielding of fuel oil service piping
 - Lubricating oil system
 - Air-intake system
 - Exhaust system
 - Shielding and insulation of exhaust pipes, assembly
 - Governor arrangements
 - Safety systems and devices and associated failure modes and effects analysis
 - Control oil system
 - Bleed/cooling/seal air system
 - Cooling system
 - Electrical and instrumentation schematics
 - Accessory drives
 - Water wash
 - Enclosure arrangement
 - Fire protection (gas turbine manufacturer supplied)
- 1.5.3 Data
 - Rated power, maximum intermittent power for 1 hour operating time, maximum power (peak)
 - Rated engine speed, including gas generator and power turbine speeds and limits (rpm)
 - Rated compressor discharge temperature and limit
 - Rated power turbine inlet temperature and limit
 - Other engine limiting parameters
 - Compressor maps
 - Allowable combustor outlet temperature spread
 - Combustion fuel equivalence ratio
 - Sense of rotation (clockwise/counterclockwise)
 - Maximum temperature at which rated power can be achieved
 - Compressor configuration
 - Combustor configuration

Turbine configuration
Mass and moment of inertia of rotating elements
Balancing data
Type test schedule, measurements and data
Manufacturer's shop test schedule
Manufacturer's recommended overhaul schedule

1.5.4 Materials

Material specifications (including density, Poisson's ratio, range of chemical composition, room-temperature physical properties and, where material is subject to temperatures exceeding 427°C (800°F), the elevated temperature mechanical properties, as well as creep rate and rupture strength for the design service life).

1.5.5 Calculations and Analyses

Design basis for turbine and compressor rotors and blading including calculations or test results to substantiate the suitability and strength of components for the intended service.

Blade containment strength, see 4-2-3/5.9.

Design service life data

Vibration analysis of the entire propulsion shafting system; see 4-2-3/5.1.2 and 4-3-2/7.

3 Materials

3.1 Material Specifications and Tests

Materials entered into the construction of gas turbines are to conform to specifications approved in connection with the design. Copies of material specifications and purchase orders are to be submitted to the Surveyor for information and verification.

Except as noted in 4-2-3/3.3, the following materials are to be tested in the presence of, inspected and certified by the Surveyor. The materials are to meet the specifications of Part 2, Chapter 3, or to the requirements of the specifications approved in connection with the design:

- i) *Forgings*: Compressor and turbine rotors, shafts, couplings, coupling bolts, integral gears and pinions.
- ii) *Castings*: Compressor and turbine casings where the temperature exceeds 232°C (450°F) or where approved for use in place of any of the above forgings.
- iii) *Plates*: Plates for casings of fabricated construction where the casing pressure exceeds 41.4 bar (42.9 kgf/cm², 600 psi) or the casing temperature exceeds 371°C (700°F).
- iv) *Blade material*: Material for all turbine blades.
- v) *Pipes, pipe fittings and valves*: See 4-6-1/Table 1 and 4-6-1/Table 2.

3.3 Alternative Materials and Tests

3.3.1 Alternative Specifications

Material manufactured to specifications other than those given in Part 2, Chapter 3 may be accepted, provided that such specifications are approved in connection with the design and that they are verified or tested by a Surveyor, as applicable, as complying with the specifications.

3.3.2 Steel-bar Stock

Hot-rolled steel bars up to 305 mm (12 in.) in diameter may be used when approved for use in place of any of the forgings as per 4-2-3/3.1i) above, under the conditions outlined in Section 2-3-8.

3.3.3 Materials for Turbines of 375 kW (500 hp) Rated Power or Less

Materials for turbines of 375 kW (500 hp) rated power or less, including shafting, integral gears, pinions, couplings and coupling bolts will be accepted on the basis of the material manufacturer's certified test reports and a satisfactory surface inspection and hardness check witnessed by the Surveyor. Coupling bolts manufactured to a recognized bolt standard and used as coupling bolts do not require material testing.

3.3.4 Certification Under Quality Assurance Assessment

For gas turbines certified under quality assurance assessment as provided for under 4-2-3/13.3.2(b), material tests required by 4-2-3/3.1 need not be witnessed by the Surveyor; such tests may be conducted by the turbine manufacturer whose certified material test reports will be accepted instead.

5 Design

5.1 Rotors and Blades

5.1.1 Criteria

Rotors, bearings, discs, drums and blades are to be designed in accordance with sound engineering principles, taking into consideration criteria such as fatigue, high temperature creep, etc. Design criteria along with engineering analyses substantiating the suitability of the design for the rated power and speed are to be submitted for review.

Design criteria are to include the design service life, which is the maximum number of hours of operation at rated power and speed. The service life between major overhauls is generally not to be less than 5000 hours or the equivalent of one year of the vessel's service.

The rated power is to be taken as that developed at the lowest expected inlet air temperature. In no case is this temperature to exceed 15°C (59°F).

5.1.2 Vibration

The designer or builder is to evaluate the shafting system for different modes of vibrations (torsional, axial, lateral) and their coupled effect, as appropriate.

5.3 Operation Above the Rated Speed and Power

Where operation above the rated power and speed for short duration is required in service, the design criteria for such operation, along with operating envelope, engineering analyses and type test data, are to be submitted for review.

5.5 Overhaul Interval

The manufacturer's recommended overhaul schedule is to be submitted for information and record and is to be considered with the design service life indicated in 4-2-3/5.1. As far as practicable, the overhaul schedule is to coincide with the survey cycle or Continuous Survey – Machinery cycle specified in Part 7.

5.7 Type Test Data

The manufacturer is to submit type test data in support of the design. The type test is to be witnessed and certified by a Surveyor or by an independent agency. The type test data are to contain at least the test schedule, measurements taken during the tests and test results. Properly documented, actual operational experience may be considered in lieu of type test data.

5.9 Casing

The gas turbine casing is to be designed such that, at overspeed up to 15% above the rated speed, any failure of blades or blade attachment devices will be contained.

Containment strength calculations, or other method such as computer simulation or impingement test, verifying the above requirement are to be submitted for review.

7 Gas Turbine Appurtenances

7.1 Overspeed Protective Devices

All propulsion and generator turbines are to be provided with overspeed protective devices to prevent the rated speed from being exceeded by more than 15%.

Where two or more turbines are coupled to the same output gear without clutches, the use of only one overspeed protective device for all turbines may be considered. This is not to prevent operation with one or more turbines uncoupled.

7.3 Operating Governors for Propulsion Gas Turbines

Propulsion turbines coupled to reverse gear, electric transmission, controllable-pitch propeller or similar are to be fitted with a separate independent speed governor system in addition to the overspeed protective device specified in 4-2-3/7.1. This governor system is to be capable of controlling the speed of the unloaded turbine without bringing the overspeed protective device into action.

7.5 Operating Governors for Turbines Driving Electric Generators

7.5.1 Speed Governing

An operating governor is to be fitted to each gas turbine driving propulsion, vessel service or emergency electric generator. The governor is to be capable of automatically maintaining the turbine speed within the following limits.

7.5.1(a) The transient frequency variations in the electrical network when running at the indicated loads below are to be within $\pm 10\%$ of the rated frequency when:

- i) Running at full load (equal to rated output) of the generator and the maximum electrical step load is suddenly thrown off;

In the case where a step load equivalent to the rated output of a generator is thrown off, a transient frequency variation in excess of 10% of the rated frequency may be acceptable, provided the overspeed protective device fitted in addition to the governor, as required by 4-2-3/7.1, is not activated.

- ii) Running at no load and 50% of the full load of the generator is suddenly thrown on, followed by the remaining 50% after an interval sufficient to restore the frequency to steady state.

In all instances, the frequency is to return to within $\pm 1\%$ of the final steady state condition in not more than five (5) seconds.

7.5.1(b) For gas turbines driving emergency generators, the requirements of 4-2-3/7.5.1(a)ii) above are to be met. However, if the sum of all emergency loads that can be automatically connected is more than 50% of the full load of the emergency generator, the sum of the emergency loads is to be used as the first applied load.

7.5.1(c) The permanent frequency variation is to be within $\pm 5\%$ of the rated frequency at any load between no load and the full load.

7.5.2 Load Sharing

Gas turbines driving AC generators that operate in parallel are to have the following governor characteristics. In the range between 20% and 100% of the combined rated load of all generators, the load on any individual generator will not differ from its proportionate share of the total combined load by more than the lesser of the following:

- 15% of the rated power of the largest generator or
- 25% of the individual generator.

7.5.3 Fine Adjustments

Provisions are to be made to adjust the governors sufficiently fine in order to permit a load adjustment within the limits of 5% of the rated load at normal frequency.

7.5.4 Turbines Driving Electric Propulsion Generators

For gas turbines driving electric propulsion generators, where required by the control system, this governor is to be provided with means for local hand control, as well as for remote adjustment from the control station.

7.7 Safety Systems and Devices

7.7.1 General

Gas turbines are to be fitted with automatic safety systems and devices for safeguards against hazardous conditions arising from malfunctions in their operations. The design of such systems and devices is to be evaluated with failure mode and effect analysis, which is to be submitted for review.

7.7.2 Automatic Shutdown

Gas turbines are to be fitted with a quick acting device which will automatically shut off fuel supply in the event of:

- i) Overspeed;
- ii) Excessive high vacuum at compressor inlet;
- iii) Low lubricating oil pressure;
- iv) Low lubricating oil pressure in reduction gear;
- v) Loss of flame during operation;
- vi) Excessive vibration;
- vii) Excessive axial displacement of each rotor (except for gas turbines fitted with roller bearings); or
- viii) Excessively high exhaust gas temperature;

7.7.3 Automatic Temperature Controls

Gas turbines are to be fitted with automatic control systems to maintain steady state temperatures in the following systems throughout the turbines' normal operating ranges:

- i) Lubricating oil;
- ii) Fuel oil (or in lieu of temperature, viscosity);
- iii) Exhaust gas.

7.7.4 Starting System Safety

7.7.4(a) Automatic purging. Prior to commencing the ignition process, automatic purging is required for all starts and restarts. The purge phase is to be of sufficient duration so as to clear all parts of the turbine of accumulation of liquid or gaseous fuel.

7.7.4(b) Preset time. The starting control system is to be fitted with ignition detection devices. If light off does not occur within a preset time, the control system is to automatically abort the ignition, shut off the main fuel valve and commence a purge phase.

7.7.5 Alarms and Shutdowns

4-2-3/Table 1 provides a summary of the required alarms and, where applicable, the corresponding requirements for shutdowns.

TABLE 1
List of Alarms and Shutdowns

<i>Monitored Parameter</i>	<i>Alarm</i>	<i>Shutdown</i>
Speed	High	Required ⁽²⁾
Lubricating oil pressure	Low ⁽¹⁾	Required ⁽²⁾
Lubricating oil pressure of reduction gear	Low ⁽¹⁾	Required ⁽²⁾
Differential pressure across lubricating oil filter	High	
Lubricating oil temperature	High	
Fuel oil supply pressure	Low	
Fuel oil temperature	High	
Cooling medium temperature	High	
Bearing temperature	High	
Flame and ignition	Failure	Required ⁽²⁾
Automatic starting	Failure	
Vibration	Excessive ⁽¹⁾	Required ⁽²⁾
Axial displacement of rotor	High	Required ^(2, 3)
Exhaust gas temperature	High ⁽¹⁾	Required ⁽²⁾
Vacuum at compressor inlet	High ⁽¹⁾	Required ⁽²⁾
Control system power	Loss	

Notes:

- 1 Alarm is to be set at a point prior to that set for shutdown.
- 2 Each shutdown is to be accompanied by own alarm.
- 3 Except where fitted with roller bearings.

7.9 Hand Trip Gear

Hand trip gear for shutting off the fuel in an emergency is to be provided locally at the turbine control platform and, where applicable, at the centralized control station.

7.11 Air-intake Filters and Anti-icing

Air intake is to be provided with demisters and filters to minimize the entry of water and harmful foreign material. They are to be so designed as to prevent the accumulation of salt deposits on the compressor and turbine blades. Means are to be provided to prevent icing in the air intake.

7.13 Silencers

Inlet and exhaust silencers are to be fitted to limit the sound power level at one meter from the gas turbine system to 110 dB for unmanned machinery spaces or to 90 dB for manned machinery spaces.

9 Piping and Electrical Systems for Gas Turbines

The requirements of piping and electrical systems associated with operation of gas turbines for propulsion, electric power generation and vessel's safety are provided in Section 4-6-5, Section 4-6-7 and Section 4-8-2. These systems include:

Fuel oil:	4-6-5/3 (see 4-6-5/3.7 in particular)
Lubricating oil:	4-6-5/5 (see 4-6-5/5.3 and 4-6-5/5.5 in particular)
Cooling water:	4-6-5/7
Starting air:	4-6-5/9
Electric starting	4-8-2/11.11
Hydraulic system	4-6-7/3
Exhaust gas:	4-6-5/11.11

11 Installation of Gas Turbines

11.1 Pipe and Duct Connections

Pipe or duct connections to the gas turbine casing are to be made in such a way as to prevent the transmission of excessive loads or moments to the turbine.

11.3 Intake and Exhaust

Air inlets are to be located as high as possible to minimize water intake, and are to be fitted with baffle, demisters, anti-icing arrangements and silencers as indicated in 4-2-3/7.11 and 4-2-3/7.13. Air-intake ducting is to be arranged in accordance with the turbine manufacturer's recommendations with a view to providing the gas turbine with a uniform pressure and velocity flowfield at the compressor inlet. The exhaust outlets are to be so located as to prevent reingestion of exhaust gas into the intake.

11.5 Hot Surfaces

Hot surfaces likely to come into contact with the crew during operation are to be suitably guarded or insulated. Hot surfaces likely to exceed 220°C (428°F), and which are likely to come into contact with any leakage, under pressure or otherwise, of fuel oil, lubricating oil or other flammable liquid, are to be suitably insulated with non-combustible materials that are impervious to such liquid. Insulation material not impervious to oil is to be encased in sheet metal or an equivalent impervious sheath.

13 Testing, Inspection and Certification of Gas Turbines

13.1 Shop Inspection and Tests

The following shop tests and inspection are to be witnessed by a Surveyor on all gas turbines required to be certified by ABS under 4-2-3/1.1.

13.1.1 Material Tests

Materials entered into the construction of turbines are to be tested in the presence of a Surveyor in accordance with the provisions of 4-2-3/3.

13.1.2 Welded Fabrication

All welded fabrication is to be conducted with qualified welding procedures, by qualified welders, and with welding consumables acceptable to the Surveyors. See Section 2-4-2.

13.1.3 Pressure Tests

Turbine casings are to be subjected to a pressure test of 1.5 times the highest pressure in the casing during normal operation. Turbine casings may be divided by temporary diaphragms to allow for an even distribution of the test pressures. Where hydrostatic tests are not practicable, alternative tests to determine soundness and workmanship are to be submitted for consideration and approval in each case. Intercoolers and heat exchangers are to be hydrostatically tested on both sides to 1.5 times the design pressure.

13.1.4 Rotor Balancing

All finished compressor and turbine rotors are to be dynamically balanced at a speed equal to the natural period of the balancing machine and rotor, combined.

13.1.5 Shop Trial

Upon completion of fabrication and assembly, each gas turbine is to be subjected to a shop trial in accordance with the manufacturer's test schedule, which is to be submitted for review before the trial. During the trial, the turbine is to be brought up to its overspeed limit to enable the operation of the overspeed protective device to be tested.

13.3 Certification of Gas Turbines

13.3.1 General

Each gas turbine required to be certified by 4-2-3/1.1 is:

- i) To have its design approved by ABS; for which purpose, plans and data as required by 4-2-3/1.5 are to be submitted to ABS for approval, and a gas turbine of the same type is to have been satisfactorily type tested or to have a documented record of satisfactory service experience (see 4-2-3/5.7);
- ii) To be surveyed during its construction for compliance with the approved design, along with, but not limited to, material and nondestructive tests, pressure tests, dynamic balancing, performance tests, etc., as indicated in 4-2-3/13.1, all to be carried out to the satisfaction of the Surveyor.

13.3.2 Approval Under Type Approval Program

13.3.2(a) Product design assessment. Upon application by the manufacturer, each model of a type of turbine may be design assessed as described in 1-1-A3/5.1. For this purpose, each design of a turbine type is to be approved in accordance with 4-2-3/13.3.1i). The type test, however, is to be conducted in accordance with an approved test schedule and is to be witnessed by a Surveyor. Turbine so approved may be applied to ABS for listing on the ABS website as Products Design Assessed. Once listed, and subject to renewal and updating of certificate as required by 1-1-A3/5.7, turbine particulars will not be required to be submitted to ABS each time the turbine is proposed for use on board a vessel.

13.3.2(b) Mass produced turbines. A manufacturer of mass-produced turbines, who operates a quality assurance system in the manufacturing facilities, may apply to ABS for quality assurance assessment described in 1-1-A3/5.5 (PQA).

Upon satisfactory assessment under 1-1-A3/5.5 (PQA), turbines produced in those facilities will not require a Surveyor's attendance at the tests and inspections indicated in 4-2-3/13.3.1ii). Such tests and inspections are to be carried out by the manufacturer whose quality control documents will be accepted. Certification of each engine will be based on verification of approval of the design and on continued effectiveness of the quality assurance system. See 1-1-A3/5.7.1(a).

13.3.2(c) Non-mass Produced Gas Turbines. A manufacturer of non-mass produced turbines, who operates a quality assurance system in the manufacturing facilities, may apply to ABS for quality assurance assessment described in 1-1-A3/5.3.1(a) (Manufacturers Procedure) and 1-1-A3/5.3.1(b) (RQS). Certification to 1-1-A3/5.5 (PQA) may also be considered in accordance with 4-1-1/Table 1.

13.3.2(d) Type Approval Program. Turbine types which have their designs approved in accordance with 4-2-3/13.3.2(a) and the quality assurance system of their manufacturing facilities approved in accordance with 4-2-3/13.3.2(b) or 4-2-3/13.3.2(c) will be deemed Type Approved and will be eligible for listing on the ABS website as Type Approved Product.

13.5 Shipboard Trials

After installation, each gas turbine, including all starting, control and safety system, is to be operated in the presence of the Surveyor to satisfactorily demonstrate function and freedom from harmful vibration at speeds within the operating range. Each gas turbine is also to operate to the overspeed limit to test the function of the overspeed governor. The means for the propulsion system to reverse are to be demonstrated and recorded.

15 Spare Parts

Spare parts are not required for purposes of classification. The maintenance of spare parts aboard each vessel is the responsibility of the owner.

PART

4

CHAPTER 2 Prime Movers

SECTION 3 Appendix 1 – Plans and Data for Gas Turbines

For each type of gas turbine to be approved, the drawings and data listed in the following table, and as applicable to the type of gas turbine, are to be submitted for approval (A) or for information (R) by each engine manufacturer. After the approval of an engine type has been given by ABS for the first time, only those documents as listed in the table, which have undergone substantive changes, will have to be submitted again for consideration by ABS. In cases where both (R) and (A) are shown, the first refers to cast components and the second to welded components. Bill of materials is to include material specification of the components, as listed.

<i>No.</i>	<i>A/R</i>	<i>Item</i>
1	A	Certified dimensional outline drawing and list of connections
2	A	Cross-sectional assembly drawing and bill of materials
3	A	Casings assembly and bill of materials
4	A	Foundations and fastening
5	A	Combustion chambers
6	A	Gasifiers
7	A	Regenerators or recuperators and Intercoolers and bill of materials
8	A	Turbine rotors and bill of materials
9	A	Compressor rotors and bill of materials
10	A	Compressor and turbine discs and bill of materials
11	A	Blading details and bill of material
12	A	Shafts and bill of materials
13	A	Bearing assembly and bill of materials
14	A	Thrust bearing assembly, performance data and bill of materials
15	A	Shaft coupling assembly including coupling alignment diagram and procedure and bill of materials
16	A	Clutches and brakes details and bill of materials
17	A	Starting arrangement
18	A	Fuel oil system including fuel injector system operational schematic and components drawing with connection schedule and bill of materials
19	A	Shielding of fuel oil service piping
20	A	Lubricating oil system schematic and bill of material
21	A	Air-intake system and air intake model test report
22	A	Exhaust system
23	A	Shielding and insulation of exhaust pipes, assembly
24	A	Governor arrangements including governor control and trip system data
25	A	Safety systems and devices and associated Failure Modes, Effects and Criticality Analysis (FMECA)
26	A	Control oil system assembly and arrangement drawing
27	R	Bleed/cooling/seal air schematic and bill of materials

No.	A/R	Item
28	A	Cooling system
29	A	Electrical and instrumentation schematics and arrangement drawings, list of terminations, and bill of materials
30	A	Accessory drive
31	A	Water wash
32	A	Enclosure arrangement
33	A	Fire protection
34	R	Gas turbine particulars (rated power, rated speed, max. temperature at which rated power can be achieved, etc.)
35	R	Speed vs power curves at site rated conditions
36	R	Ambient temperature vs power curves at site rated conditions
37	R	Output power vs shaft speed curves at site rated conditions
38	R	Heat rate correction factors
39	R	Type test schedule, measurements and data
40	R	Manufacturer's shop test schedule
41	R	Manufacturer's recommended overhaul schedule
42	R	Computer Steady State and Transient performance program (engine mounted system)
43	R	Engine Health Monitoring (EHM) equipment and program, where specified
44	R	Hot Section Repair Interval analyses
45	A	Welding procedures
46	R	B10 Bearing life analysis
47	R	Blading vibration analysis data
48	R	Lateral critical analysis
49	R	Torsional critical analysis report
50	R	Transient torsional analysis report
51	R	Allowable piping flange loading, as applicable
52	R	Spring mass model analysis, as applicable

PART

4

CHAPTER 2 Prime Movers

SECTION 4 Steam Turbines

1 General

1.1 Application

Steam turbines having a rated power of 100 kW (135 hp) and over, intended for propulsion and for auxiliary services essential for propulsion, maneuvering and safety (see 4-1-1/1.3) of the vessel, are to be designed, constructed, tested, certified and installed in accordance with the requirements of this section.

Steam turbines having a rated power of less than 100 kW (135 hp) are not required to comply with the provisions of this section but are to be designed, constructed and equipped in accordance with good commercial and marine practice. Acceptance of such steam turbines will be based on manufacturer's affidavit, verification of steam turbines nameplate data and subject to a satisfactory performance test after installation conducted in the presence of the Surveyor.

Steam turbines having a rated power of 100 kW (135 hp) and over, intended for services considered not essential for propulsion, maneuvering and safety, are not required to be designed, constructed and certified by ABS in accordance with the provisions of this section. However, they are to comply with safety features, such as overspeed protection, etc., as provided in 4-2-4/7 hereunder, as applicable, and are subject to a satisfactory performance test after installation, conducted in the presence of the Surveyor.

Piping systems of steam turbines, in particular, steam, condensate and lubricating oil systems are given in Section 4-6-6.

1.3 Definitions

For the purpose of this section the following definitions apply:

1.3.1 Rated Power

The *Rated Power* of a turbine is the maximum power output at which the turbine is designed to run continuously at its rated speed.

1.3.2 Rated Speed

The *Rated Speed* is the speed at which the turbine is designed to run continuously at its rated power. The rated speed is to be used for making strength calculations.

1.3.3 Turbine Overspeed Limit

The *Overspeed Limit* is the maximum intermittent speed allowed for a turbine in service. It is not to exceed the rated speed by more than 15% and is to be the maximum permissible setting of the overspeed governor.

1.3.4 Operating Temperature

The requirements for steam turbine rotors and blades in 4-2-4/5.3 and 4-2-4/5.5 are based on a maximum operating temperature at the turbine inlet of 427°C (800°F).

Installations for which this maximum operating temperature is exceeded will be subject to special consideration of the design criteria.

1.5 Plans and Particulars to be Submitted

1.5.1 Steam Turbine Construction

Sectional assembly

Casings

Foundation and fastening

Turbine rotors

Turbine discs

Blading

Shafts

Bearing arrangements

1.5.2 Steam Turbine Systems and Appurtenances

Couplings

Clutches

Steam inlet and exhaust system

Lubrication system.

Governor arrangements

Monitoring and safety arrangements

1.5.3 Data

Rated speed

Rated power

Mass and velocity of rotating elements

Area of wheel

Moment of inertia of wheel profile area

Center of gravity of blade and root

Balancing data

Manufacturer's shop operating test schedule

1.5.4 Materials

Material specifications (including density, Poisson's ratio, range of chemical composition, room-temperature physical properties and, where material is subject to temperatures exceeding 427°C (800°F), the high-temperature strength characteristics, as well as creep rate and rupture strength for the design service life).

1.5.5 Calculations and Analyses

Design basis for turbine rotors and blading including calculations or test results to substantiate the suitability and strength of components for the intended service.

A vibration analysis of the entire propulsion shafting system; see 4-2-4/5.3.4 and 4-3-2/7.

3 Materials

3.1 Material Specifications and Tests

Materials entered into the construction of turbines are to conform to specifications approved in connection with the design. Copies of material specifications and purchase orders are to be submitted to the Surveyor for information and verification.

Except as noted in 4-2-4/3.3, the following materials are to be tested in the presence of, inspected and certified by the Surveyor in accordance with the requirements of Part 2, Chapter 3 or to the requirements of the specifications approved in connection with the design:

- i) *Forgings*: Discs and rotor drums, shafts and rotors, couplings, coupling bolts, integral gears and pinions for all turbines.
- ii) *Castings*: Turbine casings and maneuvering valves where the temperature exceeds 232°C (450°F) or where approved for use in place of any of the above forgings.
- iii) *Plates*: Plates for turbine casings of fabricated construction where the casing pressure exceeds 41.4 bar (42.9 kgf/cm², 600 psi) or the casing temperature exceeds 371°C (700°F).
- iv) *Blade material*: Material for all turbine blades (hardness or chemical composition check-tested).
- v) *Pipes, pipe fittings and valves*: See 4-6-1/Table 1 and 4-6-1/Table 2, except for maneuvering valves as provided for in 4-2-4/3.1ii) above.

3.3 Alternative Materials and Tests

3.3.1 Alternative Specifications

Material manufactured to specifications other than those given in Part 2, Chapter 3, may be accepted, provided that such specifications are approved in connection with the design and that they are verified or tested by a Surveyor, as applicable, as complying with the specifications.

3.3.2 Steel-bar Stock

Hot-rolled steel bars up to 305 mm (12 in.) in diameter may be used when approved for use in place of any of the forgings as per 4-2-4/3.1i) above, under the conditions outlined in Section 2-3-8.

3.3.3 Materials for Turbines of 375 kW (500 hp) Rated Power or Less

Materials for turbines of 375 kW (500 hp) rated power or less, including shafting, integral gears, pinions, couplings and coupling bolts will be accepted on the basis of the material manufacturer's certified test reports and a satisfactory surface inspection and hardness check witnessed by the Surveyor. Coupling bolts manufactured to a recognized bolt standard will not require material testing.

3.3.4 Certification Under Quality Assurance Assessment

For steam turbines certified under quality assurance assessment as provided for in 4-2-4/13.3.2(b), material tests required by 4-2-4/3.1 need not be witnessed by the Surveyor; such tests are to be conducted by the turbine manufacturer whose certified material test reports will be accepted instead.

5 Design

In lieu of the design rules provided hereunder, ABS will consider designs that are substantiated by sound engineering analyses conducted for all designed operating conditions, and taking into consideration strength criteria such as fatigue, high temperature creep, torsional vibration, etc., as appropriate.

5.1 Casings

5.1.1 Castings

Turbine casings and associated fixtures that are subject to pressure are to be of a design and made of material suitable for the stress and temperatures to which they may be exposed. Cast iron and cast steel may be considered suitable where the maximum operating temperature does not exceed 232°C (450°F) and 427°C (800°F), respectively. Where the maximum operating temperature exceeds the above temperature, a thermal stress analysis of the casing is to be submitted for review.

All castings are to be heat-treated to remove internal stresses.

5.1.2 Seals and Drains

Casings are to be provided with suitable seals. Drains are to be fitted in places where water or oil may collect.

5.1.3 Overpressure Protection

Turbine casings are to be fitted with means to prevent overpressure; see 4-2-4/7.11.

5.3 Rotor Shafts

5.3.1 General

The diameter of a turbine rotor shaft is to be determined by the following equations:

$$d = K \cdot \sqrt[6]{(bT)^2 + (mM)^2}$$

$$b = 0.073 + \frac{n}{Y}$$

$$m = \frac{c_1}{c_2 + Y}$$

where

d = shaft diameter at section under consideration; mm (in.)

Y = yield strength (see 2-3-1/13.3); N/mm² (kgf/mm², psi)

T = torsional moment at rated speed; N-m (kgf-cm, lbf-in)

M = bending moment at section under consideration; N-m (kgf-cm, lbf-in)

K , n , c_1 and c_2 are constants given in the following table:

	<i>SI units</i>	<i>MKS units</i>	<i>US units</i>
K	5.25	2.42	0.10
n	191.7	19.5	27800
c_1	1186	121	172000
c_2	413.7	42.2	60000

5.3.2 Shaft Diameters in way of Rotors

Where rotor members are fitted by a press or shrink fit, or by keying, the diameter of the shaft in way of the fitted member is to be increased not less than 10%.

5.3.3 Astern Power

In determining the required size of coupling shafting transmitting astern power, the astern torque is to be considered when it exceeds the transmitted ahead torque.

5.3.4 Vibration

The designer or builder is to evaluate the entire propulsion shafting system for different modes of vibrations (torsional, axial, lateral) and their coupled effect, as appropriate.

5.5 Blades

Blades are to be so designed as to avoid abrupt changes in section and to provide an ample amount of stiffness to minimize deflection and vibration. The area at the root of the blade is not to be less than that given in the following equation based upon either the tensile strength or yield strength of the material.

<i>SI units</i>	<i>MKS units</i>	<i>US units</i>
$A = \frac{4.39WN^2r}{F}$	$A = \frac{0.45WN^2r}{F}$	$A = \frac{114WN^2r}{F}$

Notes:

- 1 These equations are based solely upon centrifugal stress consideration. Designers/manufacturers are to take into consideration vibrations at speeds within the operating range.
- 2 Where turbine blades are designed with $F = 2Y$ resulting in a safety factor against ultimate strength of less than four, a dye-penetrant or magnetic-particle inspection is to be made of each individual rotor blade.

where

- A = minimum blade root areas; cm² (in²)
 W = mass of one blade; kg (lb)
 N = rpm at rated speed divided by 1000
 r = radius of center of gravity of blade from centerline of shaft; cm (in.)
 U = minimum tensile strength of material; N/mm² (kgf/mm², psi)
 Y = yield strength of material (2-3-1/13.3); N/mm² (kgf/mm², psi)
 F = U or optionally $2Y$ (See Note 2 under the equations above)

5.7 Discs or Drums

5.7.1 General

The following strength requirements are applicable only where creep and relaxation are not the determining factors in design, and their use does not relieve the manufacturer from responsibility for excessive creep or relaxation at normal operating temperatures. In general, they apply to installations where maximum operating temperature at the superheater outlet does not exceed 427°C (800°F).

Where the maximum operating temperature at the superheater outlet exceeds 427°C (800°F) and the reliable creep rate and rupture strength for the design service life are submitted, the disk or drum design will be evaluated based on submitted engineering analysis.

5.7.2 Factors of Safety

The stress at any point in the disc or drum section is not to exceed the value Y/f , where Y is the yield strength of the material and f is the factor of safety given in the following table.

	<i>Built-up rotor</i>		<i>Solid rotor</i>	
	<i>Propulsion</i>	<i>Auxiliary</i>	<i>Propulsion</i>	<i>Auxiliary</i>
Radial stress, R	2.5	2.25	2.5	2.25
Tangential stress, T	2.5	2.25	2	2
Mean tangential stress ⁽¹⁾ , T_m	3	3	3	3

- 1 T_m is not to be higher than ultimate tensile strength divided by a factor of safety of 4.

5.7.3 Symbols

The symbols used in the equations are as follows [units of measure are given in the order of SI units (MKS units, US units)]:

- R = radial stress; N/mm² (kgf/mm², psi)
- T = tangential stress; N/mm² (kgf/mm², psi)
- Y = yield strength (see 2-3-1/13.3); N/mm² (kgf/mm², psi)
- U = minimum tensile strength; N/mm² (kgf/mm², psi)
- S = sum of principal stresses; N/mm² (kgf/mm², psi)
- D = difference of principal stresses; N/mm² (kgf/mm², psi)
- ΔS = change in S caused by change in thickness
- ΔD = change in D caused by change in thickness
- y, y' = successive thickness of disc at step points; cm (in.)
- V = tangential velocity at rated speed; m/s (ft/s)
- n = Poisson's ratio
- w = specific mass of material; kg/cm³ (lb/in³)
- T_m = mean tangential stress; N/mm² (kgf/mm², psi)
- N = rpm at rated speed divided by 1000
- A = area of wheel profile, including the rim, on one side of axis of rotation; cm² (in²)
- I = moment of inertia of area A about the axis of rotation; cm⁴ (in⁴)
- W = total mass of blades and roots; kg (lb)
- \bar{r} = radial distance to center of gravity of W ; cm (in.)
- P = Total rim load due to centrifugal force of blades; N (kgf, lbf)

5.7.4 Elastic Stress

To calculate the elastic stresses, assume $R = 0$ at the edge of the bore in solid rotors if the inspection hole is larger than one-fourth the basic diameter in way of the discs, and at the bottom of the keyway in the bore for separate discs. Assume $R = T$ at the center for solid rotors if the inspection hole does not exceed one-fourth the basic diameter in way of the discs. Assume that T has the maximum permissible value at the starting point. Proceed step by step outward to the rim or bottom of the machined blade grooves, calculating S and D at the step points for the determination of R and T at all points on the disc or drum section, using the following equations.

$$S_2 = (S_1 + \Delta S_1) + k_1 w (1 + n)(V_1^2 - V_2^2)$$

$$D_2 V_2^2 = (D_1 + \Delta D_1) V_1^2 + k_2 w (1 - n)(V_2^4 - V_1^4)$$

where k_1 and k_2 are factors given in the following table:

	<i>SI units</i>	<i>MKS units</i>	<i>US units</i>
k_1	0.5	0.051	0.186
k_2	0.25	0.025	0.093

$$R = \frac{S - D}{2}$$

$$T = \frac{S + D}{2}$$

$$\Delta S = R(n + 1) \left(\frac{y}{y'} - 1 \right)$$

$$\Delta D = R(n - 1) \left(\frac{y}{y'} - 1 \right)$$

The calculated radial stress R at the rim or bottom of the machined blade grooves determines the maximum permissible rim load. The rim load in this calculation is the total load due to blades, roots and that portion of the rim which extends beyond the bottom of the groove, neglecting supporting effect in the rim. If in the calculation it is found that the permissible stress at any point has been exceeded, the calculation is to be repeated, assuming a value of T at the starting point sufficiently low to prevent the calculated stress from exceeding the permissible stress at any point.

5.7.5 Mean Tangential Stress

The mean tangential stress is to be calculated by the following equation:

$$T_m = T_m = \frac{c_1 w N^2 I}{A} + \frac{c_2 P}{2\pi A}$$

where

	<i>SI units</i>	<i>MKS units</i>	<i>US units</i>
P	$109.7W\bar{r}N^2$	$11.2W\bar{r}N^2$	$28.4W\bar{r}N^2$
c_1	1.10	0.11	28.4
c_2	0.01	0.01	1.0

7 Steam Turbine Appurtenances

7.1 Overspeed Protective Devices

All propulsion and auxiliary turbines are to be provided with a overspeed protective device to prevent the rated speed from being exceeded by more than 15%.

In addition to cutting off the main steam supply, where steam from other systems or exhaust steam are admitted to the turbine lower stages, they are also to be cut off at the activation of overspeed protective device.

Where two or more turbines are coupled to the same output gear, use of only one overspeed protective device for all turbines may be considered.

7.3 Operating Governors for Propulsion Turbines

Propulsion turbines coupled to reverse gear, electric transmission, controllable-pitch propeller or similar are to be fitted with a separate independent speed governor system, in addition to the overspeed protective device specified in 4-2-4/7.1. This governor system is to be capable of controlling the speed of the unloaded turbine without bringing the overspeed protective device into action.

7.5 Operating Governors for Turbines Driving Electric Generators

7.5.1 Speed Governing

An operating governor is to be fitted to each steam turbine driving propulsion or vessel service electric generator. The governor is to be capable of automatically maintaining the turbine speed within the following limits.

7.5.1(a) The transient frequency variations in the electrical network when running at the indicated loads below are to be within $\pm 10\%$ of the rated frequency when:

- i) Running at full load (equal to rated output) of the generator and the maximum electrical step load is suddenly thrown off;

In the case where a step load equivalent to the rated output of a generator is thrown off, a transient frequency variation in excess of 10% of the rated frequency may be acceptable, provided the overspeed protective device fitted in addition to the governor, as required by 4-2-1/7.5.3, is not activated.

- ii) Running at no load and 50% of the full load of the generator is suddenly thrown on, followed by the remaining 50% after an interval sufficient to restore the frequency to steady state.

In all instances, the frequency is to return to within $\pm 1\%$ of the final steady state condition in no more than five (5) seconds.

7.5.1(b) The permanent frequency variation is to be within $\pm 5\%$ of the rated frequency at any load between no load and the full load.

7.5.2 Load Sharing

Steam turbines driving AC generators that operate in parallel are to have the following governor characteristics. In the range between 20% and 100% of the combined rated load of all generators, the load on any individual generator will not differ from its proportionate share of the total combined load by more than the lesser of the following:

- 15% of the rated power of the largest generator
- 25% of the individual generator

7.5.3 Fine Adjustments

Provisions are to be made to adjust the governors sufficiently fine in order to permit a load adjustment within the limits of 5% of the rated load at normal frequency.

7.5.4 Turbines Driving Electric Propulsion Generators

For steam turbines driving electric propulsion generators, where required by the control system, this governor is to be provided with means for local hand control as well as remote adjustment from the control station.

7.7 Hand and Automatic Tripping

Arrangements are to be provided for shutting off steam to propulsion turbines by suitable hand trip gear situated at the main control console and at the turbine itself. For auxiliary steam turbines, hand tripping is to be arranged in the vicinity of the turbine overspeed protective device. The hand tripping gear is to shut off both the main and exhaust steam supplies to the turbines.

Automatic means of shutting off the steam supply (including exhaust steam supply) through a quick acting device is also to be fitted for all steam turbines upon overspeed (see 4-2-4/7.1) and upon failure of the lubricating oil system (see 4-6-6/9). See also 4-2-4/7.11 for back-pressure trip.

7.9 Shaft Turning Gear

Propulsion turbines are to be equipped with a slow turning gear, providing for rotation in both directions. For auxiliary turbines, provisions are to be made that allow at least for shaft turning by hand.

For vessels fitted with remote propulsion control, the turning gear status is to be indicated at each remote propulsion control station. In addition, interlock is to be fitted to prevent operation of the turbine when the turning gear is engaged, and vice versa. See also 4-9-2/Table 2.

In the propulsion machinery space intended for centralized or unattended operation (**ACC** or **ACCU** notation), the non-rotation of the propulsion shaft in excess of a predetermined duration on a standby or stop maneuver is to be alarmed at the centralized control station and other remote control stations. In addition, for the unattended propulsion machinery space (**ACCU** notation), whenever such duration is exceeded, means for automatic roll-over of the propulsion turbine shaft is to be fitted. See also 4-9-6/Table 2.

7.11 Overpressure Protection

Sentinel valves or equivalent are to be fitted to all main and auxiliary steam turbine exhausts to provide a warning of excessive pressure to personnel in the vicinity of the exhaust end of steam turbines. Auxiliary steam turbines sharing a common condenser are to be fitted with back-pressure trips or other approved protective device

9 Piping Systems for Steam Turbines

The requirements of piping systems essential for operation of steam turbines for propulsion, electric power generation and vessel's safety are in Section 4-6-6. These systems are:

Steam piping for propulsion turbines:	4-6-6/3.11
Steam piping for auxiliary turbines:	4-6-6/3.13
Condensers:	4-6-6/5.3.2
Lubricating oil system:	4-6-6/9
Condenser cooling system:	4-6-6/11

11 Installation of Steam Turbines

11.1 Exhaust Steam to Turbine

If exhaust steam is admitted to a turbine, means are to be provided to prevent water from entering the turbine.

11.3 Extraction of Steam

Where provision is made for extraction of steam, approved means are to be provided for preventing a reversal of flow to the turbine.

11.5 Pipe and Duct Connections

Any pipe or duct connections to the steam turbine casing are to be made in such a manner as to prevent the transmission of excessive loads or moments to the turbine casing.

11.7 Hot Surfaces

Hot surfaces likely to come into contact with crew during operation are to be suitably guarded or insulated. Hot surfaces likely to exceed 220°C (428°F), and which are likely to come into contact with any leakage, under pressure or otherwise, of fuel oil, lubricating oil or other flammable liquid, are to be suitably insulated with non-combustible materials that are impervious to such liquid. Insulation material not impervious to oil is to be encased in sheet metal or an equivalent impervious sheath.

13 Testing, Inspection and Certification of Steam Turbines

13.1 Shop Inspection and Tests

The following shop tests and inspections are to be witnessed by a Surveyor on all steam turbines required to be certified by ABS under 4-2-4/1.1.

13.1.1 Material Tests

Materials entered into the construction of turbines are to be tested in the presence of a Surveyor, in accordance with the provisions of 4-2-4/3.

13.1.2 Welded Fabrication

All welded fabrication is to be conducted with qualified welding procedures, by qualified welders and with welding consumables acceptable to the Surveyors. See Section 2-4-2.

13.1.3 Nondestructive Examination of Turbine Blades

Where turbine blades are designed with $F = 2Y$ (see 4-2-4/5.5), resulting in a safety factor against ultimate strength of less than four, dye-penetrant or magnetic-particle inspection is to be made of each rotor blade.

13.1.4 Hydrostatic Tests

Turbine casings and maneuvering valves are to be subjected to hydrostatic tests of 1.5 times the working pressure. Turbine casings may be divided by temporary diaphragms to allow for an even distribution of test pressures. Where hydrostatic tests are not practicable, alternative tests to determine soundness and workmanship are to be submitted for consideration and approval in each case.

Condensers are to have both the steam side and the water side hydrostatically tested to 1.5 times the design pressure; in any case, the test pressure on the steam side is not to be less than 1 bar (1 kgf/cm², 15 lb/in²). See also 4-6-6/5.11.2.

13.1.5 Safety Relief Valves

All safety relief valves are to be tested and set in the presence of the Surveyor.

13.1.6 Vibration and Balancing

Excessive vibration is not to occur within the operating speed range of turbines. Turbine rotors and discs are to be dynamically balanced at a speed equal to the natural period of the balancing machine and rotor combined.

13.1.7 Shop Trial

Upon completion of fabrication and assembly, each steam turbine is to be subjected to a shop trial in accordance with the manufacturer's test schedule, which is to be submitted for review before the trial. The test schedule is to specify the duration of tests and to include full load test, half load response tests, full load thrown-off tests, etc. During the trial, the turbine is to be brought up to its overspeed limit to enable the operation of the overspeed protective device to be tested. Where this is not practicable, the manufacturer may submit alternative testing methods for consideration.

13.3 Certification of Steam Turbines

13.3.1 General

Each steam turbine required by 4-2-4/1.1 to be certified is:

- i) To have its design approved by ABS, for which purpose, plans and data, as required by 4-2-4/1.5 are to be submitted to ABS for approval.
- ii) To be surveyed during its construction for compliance with the design approved, along with, but not limited to, material and nondestructive tests, hydrostatic tests, dynamic balancing, performance tests, etc., as indicated in 4-2-4/13.1, all to be carried out to the satisfaction of the Surveyor.

13.3.2 Approval Under Type Approval Program

13.3.2(a) Product design assessment. Upon application by the manufacturer, each model of a type of turbine may be design assessed, as described in 1-1-A3/5.1. For this purpose, each design of a turbine type is to be approved in accordance with 4-2-4/13.3.1i) and either satisfactorily type tested in a shop in the presence of a Surveyor or substantiated by documented satisfactory service experience. Turbine so approved may be applied to ABS for listing on the ABS website as Products Design Assessed. Once listed, and subject to renewal and updating of certificate as required by 1-1-A3/5.7, turbine particulars will not be required to be submitted to ABS each time the turbine is proposed for use onboard a vessel.

13.3.2(b) Mass produced turbines. A manufacturer of mass-produced turbines who operates a quality assurance system in the manufacturing facilities may apply to ABS for quality assurance assessment described in 1-1-A3/5.5 (PQA).

Upon satisfactory assessment under 1-1-A3/5.5 (PQA), turbines produced in those facilities will not require a Surveyor's attendance at the tests and inspections indicated in 4-2-4/13.3.1ii). Such tests and inspections are to be carried out by the manufacturer whose quality control documents will be accepted. Certification of each turbine will be based on verification of approval of the design and on continued effectiveness of the quality assurance system. See 1-1-A3/5.7.1(a).

13.3.2(c) Non-mass Produced Turbines. A manufacturer of non-mass produced turbines who operates a quality assurance system in the manufacturing facilities may apply to ABS for quality assurance assessment described in 1-1-A3/5.3.1(a) (Manufacturers Procedure) and 1-1-A3/5.3.1(b) (RQS). Certification to 1-1-A3/5.5 (PQA) may also be considered in accordance with 4-1-1/Table 1.

13.3.2(d) Type Approval Program. Turbine types which have their designs assessed in accordance with 4-2-4/13.3.2(a) and the quality assurance system of their manufacturing facilities assessed in accordance with 4-2-4/13.3.2(b) or 4-2-4/13.3.2(c) will be deemed Type Approved and will be eligible for listing on the ABS website as Type Approved Product.

13.5 Shipboard Trials

Before final acceptance, the entire installation of each steam turbine including all control and safety equipment is to be operated in the presence of the Surveyor to demonstrate its ability to function satisfactorily under operating conditions and its freedom from harmful vibration at speeds within the operating range.

Each steam turbine is to be tested to the overspeed limit in order to operate the overspeed governor.

The reversing characteristics of propulsion turbine plants are to be demonstrated and recorded.

PART

4

CHAPTER 2 Prime Movers

SECTION 4 Appendix 1 – Guidance for Spare Parts

1 General

While spare parts are not required for purposes of classification, the spare parts list below is provided as a guidance for vessels intended for unrestricted service. Depending on the turbine design, spare parts other than those listed below, such as electronic control cards, should be considered.

3 Spare Parts for Propulsion Steam Turbines

- a) One (1) set of springs for governor, relief and maneuvering valves
- b) Sufficient packing rings with springs to repack one gland of each kind and size
- c) One (1) set of thrust pads or rings, also springs where fitted, for each size turbine-thrust bearing
- d) Bearing bushings sufficient to replace all of the bushings on every turbine rotor, pinion and gear for main propulsion, spare bearing bushings sufficient to replace all of the bushings on each non-identical auxiliary-turbine rotor, pinion and gear having sleeve-type bearings or complete assemblies consisting of outer and inner races and cages complete with rollers or balls where these types of bearings are used
- e) One (1) set of bearing shoes for one face, for one single-collar type main thrust bearing where fitted. Where the ahead and astern pads differ, pads for both faces are to be provided.
- f) One (1) set of strainer baskets or inserts for filters of special design of each type and size, for oil filters.
- g) Necessary special tools.

5 Spare Parts for Steam Turbines Driving Electric Generators

- | | | |
|--------------------------------|---|-------|
| a) Main bearings | Bearing bushes or roller bearings of each size and type fitted for the shafts of the turbine rotor and of the reduction gearing, if any, for one engine | 1 set |
| b) Turbine thrust bearing | Pads for one face of tilting pad type thrust, with liners, or rings for turbine adjusting block with assorted liners, for one engine | 1 set |
| c) Turbine shaft sealing rings | Carbon sealing rings where fitted, with springs for each size and type of gland, for one engine | 1 set |
| d) Oil filters | Strainer baskets or inserts, for filters of special design, of each type and size | 1 set |

CONTENTS

SECTION 1	Gears	188
1	General	188
1.1	Application	188
1.3	Definitions	188
1.5	Plans and Particulars to be Submitted	189
3	Materials	191
3.1	Material Specifications and Test Requirements	191
3.3	Alternative Material Test Requirements	191
5	Design	192
5.1	Gear Tooth Finish	192
5.3	Bearings	192
5.5	Gear Cases	192
5.7	Access for Inspection	193
5.9	Calculation of Shafts for Gears	193
5.11	Rating of Cylindrical and Bevel Gears	194
5.13	Alternative Gear Rating Standards	194
5.15	Gears with Multiple Prime Mover Inputs	195
5.17	Rating of Gears for Intermittent Duty	195
7	Piping Systems for Gears	195
9	Testing, Inspection and Certification of Gears	195
9.1	Material Tests	195
9.3	Dynamic Balancing	195
9.5	Shop Inspection	196
9.7	Certification of Gears	196
9.9	Shipboard Trials	197
SECTION 1	Appendix 1 – Rating of Cylindrical and Bevel Gears	198
1	Application	198
3	Symbols and Units	198
5	Geometrical Definitions	200
7	Bevel Gear Conversion and Specific Formulas	201
9	Nominal Tangential Load, F_t , F_{mt}	204
11	Application Factor, K_A	204
13	Load Sharing Factor, K_γ	205
15	Dynamic Factor, K_v	205
15.1	Determination of K_v – Simplified Method	206
15.3	Determination of K_v – Single Resonance Method	207

17	Face Load Distribution Factors, $K_{H\beta}$ and $K_{F\beta}$	214
17.1	Factors Used for the Determination of $K_{H\beta}$	214
17.3	Face Load Distribution Factor for Contact Stress $K_{H\beta}$	217
17.5	Face Load Distribution Factor for Tooth Root Bending Stress $K_{F\beta}$	218
19	Transverse Load Distribution Factors, $K_{H\alpha}$ and $K_{F\alpha}$	219
19.1	Determination of $K_{H\alpha}$ for Contact Stress $K_{F\alpha}$ for Tooth Root Bending Stress	219
19.3	Limitations of $K_{H\alpha}$ and $K_{F\alpha}$	219
21	Surface Durability	220
21.1	Contact Stress	220
21.3	Permissible Contact Stress	221
21.5	Single Pair Mesh Factors, Z_B , Z_D and Mid-zone Factor Z_{M-B}	222
21.7	Zone Factor, Z_H	223
21.9	Elasticity Factor, Z_E	224
21.11	Contact Ratio Factor (Pitting), Z_ϵ	224
21.13	Bevel Gear Load Sharing Factor, Z_{LS}	224
21.15	Bevel Gear Factor (Flank), Z_K	225
21.17	Helix Angle Factor, Z_β	225
21.19	Allowable Stress Number (Contact), σ_{Hlim}	225
21.21	Life Factor, Z_N	225
21.23	Influence Factors on Lubrication Film, Z_L , Z_V and Z_R	225
21.25	Hardness Ratio Factor; Z_W	228
21.27	Size Factor, Z_X	229
21.29	Safety Factor for Contact Stress, S_H	229
23	Tooth Root Bending Strength	230
23.1	Tooth Root Bending Stress for Pinion and Wheel	230
23.3	Permissible Tooth Root Bending Stress	230
23.5	Tooth Form Factor, Y_F , Y_{Fa}	231
23.7	Stress Correction Factor, Y_S , Y_{Sa}	235
23.9	Helix Angle Factor, Y_β	236
23.11	Contact Ratio Factor, Y_ϵ	236
23.13	Bevel Gear Factor, Y_K	236
23.15	Load Sharing Factor, Y_{LS}	236
23.17	Allowable Stress Number (Bending), σ_{FE}	236
23.19	Design Factor, Y_d	237
23.21	Life Factor, Y_N	237
23.23	Relative Notch Sensitivity Factor, $Y_{\delta relT}$	237
23.25	Relative Surface Factor, Y_{RrelT}	237
23.27	Size Factor (Root), Y_X	238
23.29	Safety Factor for Tooth Root Bending Stress, S_F	239
TABLE 1	Values of the Elasticity Factor Z_E and Young's Modulus of Elasticity E	240
TABLE 2	Size Factor Z_X for Contact Stress	243
TABLE 3	Allowable Stress Number (contact) σ_{Hlim} and Allowable Stress Number (bending) σ_{FE}	244

TABLE 4	Determination of Life Factor for Contact Stress, Z_N	247
TABLE 5	Determination of Life Factor for Tooth Root Bending Stress, Y_N	248
TABLE 6	Constant K' for the Calculation of the Pinion Offset Factor γ	249
FIGURE 1	Tooth in Normal Section	250
FIGURE 2	Dimensions and Basic Rack Profile of the Tooth (Finished Profile)	251
FIGURE 3	Wheel Blank Factor C_R , Mean Values for Mating Gears of Similar or Stiffer Wheel Blank Design	252
FIGURE 4	Bevel Gear Conversion to Equivalent Cylindrical Gear	253
FIGURE 5	Definitions of the Various Diameters.....	254
SECTION 1	Appendix 2 – Guidance for Spare Parts	255
1	General	255
3	Spare Parts for Gears	255
SECTION 1	Appendix 3 – Gear Parameters	256
SECTION 2	Propulsion Shafting	265
1	General	265
1.1	Application	265
1.3	Definitions	265
1.5	Plans and Particulars to be Submitted.....	266
3	Materials.....	267
3.1	General.....	267
3.3	Weldability	267
3.5	Shaft Liners	267
3.7	Material Tests	267
5	Design and Construction.....	268
5.1	Shaft Diameters	268
5.3	Hollow Shafts.....	271
5.5	Alternative Criteria	271
5.7	Key	271
5.9	Strengthening for Navigation in Ice.....	272
5.11	Tail Shaft Propeller-end Design	272
5.13	Propeller-end Seal	272
5.15	Tail Shaft Bearings	274
5.17	Tail Shaft Liners.....	274
5.19	Couplings and Coupling Bolts.....	275
5.21	Cardan Shaft	278
7	Propulsion Shaft Alignment and Vibrations	278
7.1	General.....	278
7.3	Shaft Alignment for Vessels 61 m (200 ft) in Length and Over	278
7.5	Torsional Vibrations	281
7.7	Axial Vibrations	283

7.9	Whirling Vibrations	283
7.11	Vessels Below 61 m (200 ft) in Length	284
9	Inspection, Testing and Certification.....	284
9.1	General.....	284
9.3	Material Testing.....	284
9.5	Propulsion Shafts and Associated Parts.....	284
9.7	Flexible Couplings, Clutches, Cardan Shafts, etc.....	284
11	Installation and Trials	284
11.1	Shaft Alignment.....	284
11.3	Vibration Measurement	286
11.5	Circulating Currents.....	287
11.6	Watertight Bulkhead Penetrations for Shafting.....	287
11.7	Sea Trial.....	287
13	Tailshaft Condition Monitoring (TCM)	287
13.1	Notation.....	287
13.3	System Requirements	287
13.5	Management of the Monitored Data	288
13.7	Surveys	288
15	Tailshaft Condition Monitoring (TCM-W)	288
15.1	Notation.....	288
15.3	System Requirements	289
15.5	Management of the Monitored Data	291
15.7	Test Plan	292
15.9	Surveys	292
TABLE 1	Shaft Design Factors K and C_K for Line Shafts and Thrust Shafts	269
TABLE 2	Shaft Design Factors K and C_K for Tail Shafts and Stern Tube Shafts.....	270
TABLE 3	Maximum Values of U to be Used in Shaft Calculations	271
TABLE 4	Allowable Torsional Vibratory Stress	282
TABLE 5	Instrumentation and Alarm.....	290
FIGURE 1	Intersection between a Radial and an Eccentric Axial Bore.....	270
FIGURE 2	Typical Arrangements and Details of Fitting of Tail Shaft and Propeller.....	273
SECTION 2	Appendix 1 – Special Approval of Alloy Steel Used for Intermediate Shaft Material	293
1	Application	293
3	Torsional Fatigue Test	293
3.1	Test Conditions	293
3.3	Acceptance Criteria	293
5	Cleanliness Requirements.....	294
7	Inspection.....	295
9	Stress Concentration Factor of Slots	295

TABLE 1	Test Condition	293
TABLE 2	Cleanliness Requirements	294
TABLE 3	Chemical Composition Limits for Machinery Steel Forgings	294

SECTION 3 Propellers..... 296

1	General	296
1.1	Application	296
1.3	Definitions.....	296
1.5	Plans and Particulars to be Submitted.....	297
3	Materials.....	298
3.1	Normally Used Propeller Materials	298
3.3	Stud Materials.....	298
3.5	Material Testing	298
5	Design.....	298
5.1	Blade Thickness – Fixed Pitch Propeller	298
5.3	Blade Thickness – Controllable-pitch Propellers.....	300
5.5	Blade Thickness – Highly Skewed Fixed-pitch Propellers	301
5.7	Blades of Unusual Design	302
5.9	Blade-root Fillets.....	302
5.10	Built-up Blades	302
5.11	Strengthening for Navigation in Ice.....	302
5.13	Controllable Pitch Propellers – Pitch Actuation System.....	303
5.15	Propeller Fitting.....	304
7	Certification	308
7.1	Material Tests.....	308
7.3	Inspection and Certification	308
9	Installation, Tests and Trial.....	308
9.1	Keyed Propellers	308
9.3	Controllable Pitch Propellers – Fit of Studs and Nuts	308
9.5	Protection Against Corrosion	308
9.6	Noncorrosive, Non-pitting Alloys.....	308
9.7	Circulating Currents	308
9.9	Keyed and Keyless propellers – Contact Area Check and Securing	309
9.11	Controllable Pitch Propellers – Hydrostatic Tests.....	309
9.13	Sea Trial	309

TABLE 1	Propeller Materials	298
TABLE 2	Material Constants	306
TABLE 3	Estimated Propeller Thrust, T	307

FIGURE 1	Maximum Skew Angle	297
FIGURE 2	Rake and Rake Angle	297
FIGURE 3	Theoretical Contact Surface Between Hub and Shaft	305

SECTION 4	Steering Gears	310
1	General	310
	1.1 Application.....	310
	1.3 Basic Principles	310
	1.5 Definitions.....	310
	1.7 Steering Gear Compartment	311
	1.9 Performance.....	311
	1.11 Plans and Particulars to be Submitted	312
3	Materials.....	312
	3.1 General.....	312
	3.3 Material Testing.....	312
5	System Arrangements	313
	5.1 Power Units	313
	5.3 Rudder Actuators	313
	5.5 Single Failure Criterion.....	313
	5.7 Independent Control Systems	313
	5.9 Non-duplicated Components.....	313
	5.11 Power Gear Stops	313
	5.13 Steering Gear Torques.....	314
7	Mechanical Component Design.....	314
	7.1 Mechanical Strength.....	314
	7.3 Rudder Actuators	314
	7.5 Tillers, Quadrants and Other Mechanical Parts.....	315
	7.7 Rudder Stock to Tiller/Quadrant Connection.....	316
	7.9 Welding	317
9	Hydraulic System	317
	9.1 System Design	317
	9.3 Hydraulic Oil Reservoir and Storage Tank	318
	9.5 Piping Design	319
	9.7 Piping Components	319
11	Electrical Systems.....	319
	11.1 Power Supply Feeders	319
	11.3 Electrical Protection.....	319
	11.5 Undervoltage Release	320
	11.7 Motor Rating.....	320
	11.9 Emergency Power Supply	320
13	Control Systems.....	320
	13.1 General.....	320
	13.3 Power Supply	321
	13.5 Control System Override	322
	13.7 Hydraulic Telemotor	322
	13.9 Computer-based Systems.....	322
15	Instrumentation	322
17	Communications	324

19	Certification	324
19.1	General.....	324
19.3	Material Testing	324
19.5	Prototype Tests of Power Units	324
19.7	Components Shop Tests	324
21	Installation, Tests and Trials	324
21.1	Steering Gear Seating	324
21.3	Operating Instructions.....	324
21.5	Installation Tests.....	325
21.7	Sea Trials	325
23	Additional Requirements for Passenger Vessels.....	327
23.1	Performance	327
23.3	Sea Trials	327
25	Additional Requirements for Oil or Fuel Oil Carriers, Chemical Carriers and Gas Carriers.....	327
25.1	Vessels of 10,000 Gross Tonnage and Upwards	327
25.3	Alternative for Vessels 10,000 Gross Tonnage and Upwards but Less than 100,000 Tonnes Deadweight	327
25.5	Non-duplicated Rudder Actuators for Vessels of 10,000 Gross Tonnage and Upwards but Less than 100,000 Tonnes Deadweight.....	328
25.7	Sea Trials	329

TABLE 1	Steering Gear Instrumentation.....	323
---------	------------------------------------	-----

SECTION 5 Thrusters..... 330

1	General	330
1.1	Application	330
1.3	Class Notations.....	330
1.5	Definitions.....	331
1.7	Plans and Particulars to be Submitted.....	331
3	Materials.....	332
3.1	General.....	332
3.3	Material Testing	332
5	Design.....	332
5.1	Prime Movers	332
5.3	Propellers	333
5.5	Gears.....	336
5.7	Shafts	336
5.9	Anti-friction Bearings.....	336
5.11	Steering Systems for Vessel's Directional Control.....	336
5.12	Arrangements	337
5.13	Access for Inspection.....	338
7	Controls and Instrumentation.....	338
7.1	Control System	338
7.3	Instrumentation	338
7.5	Failure Detection and Response.....	338

9	Communications	339
11	Miscellaneous Requirements for Thruster Rooms	339
11.1	Ventilation.....	339
11.3	Bilge System for Thruster Compartments.....	339
11.5	Fire Fighting Systems.....	339
13	Certification and Trial.....	339
13.1	Survey at the Shop of the Manufacturer	339
13.3	Sea Trial.....	339
13.5	Sea Trial Results	339
15	Notification of Declared Operational Limits.....	339

TABLE 1	Instrumentation for Thrusters.....	338
---------	------------------------------------	-----

SECTION 6 Waterjets 340

1	Waterjets	340
1.1	General.....	340
1.3	Design	340
1.5	Housings	340
1.7	Reversing Mechanisms	341
1.9	Impeller Bearings	341

SECTION 7 Propulsion Redundancy 342

1	General	342
1.1	Application.....	342
1.3	Objective	342
1.5	Definitions.....	342
1.7	Plans and Data to be Submitted.....	343
3	Classification Notations.....	343
5	Single Failure Concept.....	345
5.1	Single Failure Criteria	345
7	Propulsion and Steering Capability.....	345
7.1	Vessels Without + in Class Notation.....	345
7.3	Vessels with + in Class Notation	345
9	System Design.....	346
9.1	Propulsion Machinery and Propulsors.....	346
9.3	System Segregation	346
9.5	Steering Systems	346
9.7	Auxiliary Service Systems	347
9.9	Electrical Distribution Systems	347
9.11	Control and Monitoring Systems	348
9.13	Communication Systems.....	348
11	Fire Precautions.....	348
13	Operating Manual	348

15	Test and Trial	349
15.1	Fault Simulation Test	349
15.3	Communication System Test	349
17	Survey After Construction	349
	FIGURE 1 Arrangements of Propulsion Redundancy	344

SECTION 8 Podded Propulsion Units..... 350

1	General	350
1.1	Application	350
1.3	Scope	350
1.5	Notations	350
1.7	Design Requirements	350
3	Definitions	351
5	Plans to be Submitted	351
5.1	Plans to be submitted	351
5.3	Information to be Submitted	351
7	Global Loads	352
9	Structures	353
11	Machinery and Systems	353
11.1	Seals	353
11.3	Bilge pumping System	353
11.5	Pod Shaft Bearing	353
11.7	Lubricating System	353
11.9	Steering Systems	354
11.11	Ventilation and Cooling	354
13	Electrical	354
13.1	Description of System	354
13.3	Generating Capacity	354
15	Propulsion Control and Automation	355
15.1	Local Control	355
15.3	Remote Shutdown	355
15.5	Control Systems for Steering Systems	355
15.7	Position Indicators	355
15.9	Alarms and Monitoring Systems	355
15.11	Instrumentation	355
17	Testing and Trials	356
17.1	Test Plan	356
17.3	Testing and Trials	356
	TABLE 1 Podded Propulsion Instrumentation	356
	FIGURE 1 Podded Propulsion Unit	353

SECTION 9	Contrarotating Propellers	357
1	General	357
	1.1 Application	357
	1.3 Basic Principles	357
	1.5 Definitions	357
	1.9 Plans and Particulars to be Submitted	357
3	Materials	358
5	Design	358
	5.1 Gears	358
	5.3 Shaft Diameters	358
	5.5 Propeller-end Seals	358
	5.7 Couplings and Clutches	358
	5.9 Propulsion Shaft Vibrations	359
	5.11 Propellers	359
	5.13 Access for Inspection	359
	5.15 Shaft Alignment	359
	5.17 Shaft Lubrication	359
	5.19 Propeller Fitting	360

PART

4

CHAPTER 3 Propulsion and Maneuvering Machinery

SECTION 1 Gears

1 General

1.1 Application

Gears having a rated power of 100 kW (135 hp) and over, intended for propulsion and for auxiliary services essential for propulsion, maneuvering and safety (see 4-1-1/1.3) of the vessel, are to be designed, constructed, certified and installed in accordance with the provisions of this section.

Gears having a rated power of less than 100 kW (135 hp) are not required to comply with the provisions of this Section but are to be designed, constructed and equipped in accordance with good commercial and marine practice. Acceptance of such gears will be based on the manufacturer's affidavit, verification of gear nameplate data and subject to a satisfactory performance test after installation conducted in the presence of the Surveyor.

Gears having a rated power of 100 kW (135 hp) and over, intended for services considered not essential for propulsion, maneuvering and safety, are not required to be designed, constructed and certified by ABS in accordance with the requirements of this section, but are to be installed and tested to the satisfaction of the Surveyor.

Piping systems of gears, in particular, lubricating oil and hydraulic oil, are addressed in 4-6-5/5, 4-6-6/9 and 4-6-7/3.

1.3 Definitions

For the purpose of this section, the following definitions apply:

1.3.1 Gears

The term *Gears* as used in this section covers external and internal involute spur and helical cylindrical gears having parallel axis as well as bevel gears used for either main propulsion or auxiliary services.

1.3.2 Rated Power

The *Rated Power* of a gear is the maximum transmitted power at which the gear is designed to operate continuously at its rated speed.

1.3.3 Rated Torque

The *Rated Torque* is defined by the rated power and speed and is the torque used in the gear rating calculations.

1.3.4 Gear Rating

The *Gear Rating* is the rating for which the gear is designed in order to carry its rated torque.

1.3.5 Intermittent Duty

Gear units intended for intermittent duty, that is at a higher rating than the rated power defined in 4-3-1/1.3.2 (the rated power at which the gear is designed to operate continuously at its rated speed), are to meet the requirements in 4-3-1/5.17 in addition to all applicable requirements contained in Section 4-3-1. When gear units rated for intermittent duty are installed on a vessel, the vessel's classification and operating profile shall reflect the intermittent rating. Such ratings would normally be considered for only non-commercial services or for commercial service with limited operating time in the intermittent duty service as defined by the mission profile.

1.5 Plans and Particulars to be Submitted

1.5.1 Gear Construction

General arrangement
Sectional assembly
Details of gear casings
Bearing load diagram
Quill shafts, gear shafts and hubs
Shrink fit calculations and fitting instructions
Pinions
Wheels and rims
Details of welded construction of gears

1.5.2 Gear Systems and Appurtenances

Couplings
Coupling bolts
Lubricating oil system and oil spray arrangements

1.5.3 Data

Transmitted rated power for each gear
Revolutions per minute for each gear at rated transmitted power
Bearing lengths and diameters
Length of gap between helices, if any
Distance between inner ends of bearings
Tooth form layout (see 4-3-1A1/Figure 1) or calculated data
Facewidths, net and total
Width of tooth at highest stressed section
Helix angle at reference and at pitch diameter
Helix deviation
Normal pressure angle
Transverse pressure angle at reference cylinder
Transverse pressure angle at working pitch cylinder
Reference cone angle for gears
Tip angle for gears
Cone distance for gears
Middle cone distance for gears
Normal module
Transverse module
Bending moment arm for tooth root bending stress for application of load at the point of single tooth pair contact
Working pitch diameter of gears

Tip diameter of gears
Root diameter of gears
Reference diameters
Addendum
Addendum modification coefficient of gears
Dedendum
Transverse diametral pitch
Normal base pitch
Number of gear teeth
Virtual number of spur teeth for gears
Center distance between mating gears
Length of contact in plane of rotation
Root fillet radius of gears in the critical section
Axial lead modification or lead mismatch, if any, for reference
Method of cutting and finishing gear teeth
Tooth thickness modification coefficient (midface)
Sketch of basic rack tooth form
Root radius, addendum, dedendum of basic rack
Degree of finish of tooth flank
Grade of accuracy
Tooth hardness range, including core hardness and total depth of hardness, surface to core
Mean peak-to-valley roughness of tooth root fillets
Mass of rotating parts
Balancing data
Spline data
Shrink allowance for rims and hubs
Type of coupling between prime mover and reduction gears
Type and viscosity of lubricating oil recommended by manufacturer
For a comprehensive listing of data, see Appendix 4-3-1A3.

1.5.4 Materials

The following typical properties of gear materials are to be submitted:

- Range of chemical composition
- Physical properties at room temperature
- Endurance limits for pitting resistance, contact stress and tooth root bending stress
- Heat treatment of gears, coupling elements, shafts, quill shafts, and gear cases

1.5.5 Hardening Procedure

The hardening procedure for surface hardened gears is to be submitted for review. The submittal is to include materials, details for the procedure itself, quality assurance procedures and testing procedures. The testing procedures are to include surface hardness, surface hardness depth (e.g., case depth) and core hardness. Surface hardness depth and core hardness (and their shape) are to be determined from sectioned test samples. These test samples are to be of sufficient size to provide for determination of core hardness and are to be of the same material and heat treated as the gears that they represent. Forgings are to be tested in accordance with Part 2, Chapter 3.

1.5.6 Calculations and Analyses

Bearing life calculations

Tooth coupling and spline connection calculations

3 Materials

3.1 Material Specifications and Test Requirements

3.1.1 Material Certificates

Material for gears and gear units is to conform to specifications approved in connection with the design in each case. Copies of material specifications and purchase orders are to be submitted to the Surveyor for information.

3.1.2 Material Tests

Except as noted in 4-3-1/3.3, the following materials are to be tested in the presence of and inspected by the Surveyor. The materials are to meet the specifications in Part 2, Chapter 3 or that approved in connection with the design.

- Forgings for shafting, couplings, coupling bolts.
- Forgings for through hardened, induction hardened, and nitrided gears.
- Forgings for carburized gears. See 2-3-7/3.9.3(g).
- Castings approved for use in place of any of the above forgings.

3.3 Alternative Material Test Requirements

3.3.1 Alternative Specifications

The Surveyor will inspect and test material manufactured to other specifications than those given in Part 2, Chapter 3, provided that such specifications are approved in connection with the designs and that they are clearly indicated on purchase orders which are provided for the Surveyor's information.

3.3.2 Gears Certified Under Quality Assurance Assessment

For gear units certified under quality assurance assessment provided for in 4-3-1/9.7 hereunder, material tests and inspections required in 4-3-1/3.1 need not be witnessed by the Surveyor; such tests and inspections are to be conducted by the gear manufacturer whose certified material test reports will be accepted instead.

3.3.3 Steel-bar Stock

Hot-rolled steel bars up to 305 mm (12 in.) in diameter may be used when approved for use in place of any of the forgings as per 4-3-1/3.3.1 above, under the conditions outlined in Section 2-3-8.

3.3.4 Gear Units of 375 kW (500 hp) or Less

Material for gear units of 375 kW (500 hp) or less, including shafting, gears, couplings, and coupling bolts will be accepted on the basis of the manufacturer's certified material test reports and a satisfactory surface inspection and hardness check witnessed by the Surveyor. Coupling bolts manufactured to a recognized bolt standard do not require material testing.

3.3.5 Power Takeoff Gears and Couplings

Materials for power takeoff gears and couplings that are:

- For transmission of power to drive auxiliaries that are for use in port only (e.g., cargo oil pump), and
- Declutchable from propulsion shafting may be treated in the same manner as 4-3-1/3.3.4 above, regardless of power rating.

5 Design

5.1 Gear Tooth Finish

In general the gear teeth surface finish is not to be rougher than 1.05 μm (41 $\mu\text{in.}$) arithmetic or centerline average. However, gears having a rated power below 3728 kW (5000 hp) and with a surface finish rougher than 1.05 μm (41 $\mu\text{in.}$) arithmetic or centerline average will be specially considered, taking into account the lubricant recommended by the manufacturer.

5.3 Bearings

Bearings of gear units are to be so designed and arranged that their design lubrication rate is assured in service under working conditions.

5.3.1 Journal Bearings

For journal bearings, the maximum bearing pressures, minimum oil film thickness, maximum predicted internal bearing temperature and the maximum static unit load are to be in accordance with an applicable standard such as ISO 12130-1:2001 (plain tilting plain thrust bearings), ISO 12131-1:2001 (plain thrust pad bearings), ISO 12167-1:2001 (plain journal bearings with drainage grooves), ISO 12168-1:2001 (plain journal bearings without drainage grooves), ANSI/AGMA 6032-A94, Table 8, etc.

5.3.2 Roller Bearings

The minimum L10 bearing life is not to be less than 20,000 hours for ahead drives and 5,000 hours for astern. Shorter life may be considered in conjunction with an approved bearing inspection and replacement program reflecting the actual calculated bearing life. See 4-3-5/5.9 for application to thrusters. Calculations are to be in accordance with an applicable standard such as ISO 76:1987, ISO 281:1990 (rolling bearings, for static and dynamic ratings, respectively).

5.3.3 Alternative Designs

Consideration will be given to bearing pressures exceeding the limits in the standards listed in 4-3-1/5.3.1 and 4-3-1/5.3.2 provided the manufacturer can demonstrate a reliable operating history with similar designs.

5.3.4 Shaft Alignment Analysis

For gear-shafts which are directly connected to the propulsion shafting, the load on the gear shaft bearings is to be evaluated by taking into consideration the loads resulting from the shafting alignment condition.

5.5 Gear Cases

Gear cases are to be of substantial construction in order to minimize elastic deflections and maintain accurate mounting of the gears. They are to be designed to withstand without deleterious deflection: the tooth forces generated by the gear elements, thrust bearing arrangement, line shaft alignment, prime mover(s), clutches, couplings and accessories, under all modes of operation. Additionally, the inertial effects of the gears within the case, due to 1 g horizontal and 2 g vertical dynamic forces of the ship in a seaway, are to be considered. Calculations, in accordance with the manufacturer's code of practice, substantiating these Rule requirements are to be submitted. For gear case designs for which the manufacturer can provide a satisfactory service history, submission of calculations may be waived.

5.7 Access for Inspection

The construction of gear cases is to be such that a sufficient number of access points are provided for adequate inspection of gears, checking of gear teeth contacts and measurement of thrust bearing clearance. Alternative methods such as use of special viewing devices may be considered.

5.9 Calculation of Shafts for Gears

5.9.1 General

The diameter of shafts for gears is to be determined by the following equations:

$$d = k \cdot \sqrt[6]{(bT)^2 + (mM)^2}$$

$$b = 0.073 + \frac{n}{Y}$$

$$m = \frac{c_1}{c_2 + Y}$$

where (in SI (MKS and US units), respectively):

d = shaft diameter at section under consideration; mm (in.)

Y = yield strength (see 2-1-1/13.3); N/mm² (kgf/mm², psi)

T = torsional moment at rated speed; N-m (kgf-cm, lbf-in) (See also 4-3-1/5.9.6 to account for effect of torsional vibrations, where applicable.)

M = bending moment at section under consideration; N-m (kgf-cm, lbf-in)

k , n , c_1 and c_2 are constants given in the following table:

	<i>SI units</i>	<i>MKS units</i>	<i>US units</i>
k	5.25	2.42	0.10
n	191.7	19.5	27800
c_1	1186	121	172000
c_2	413.7	42.2	60000

5.9.2 Shaft Diameter in way of Gear Wheel

Where gear wheels are fitted by a press or shrink fit, or by keying, the diameter of the shaft in way of the fitted member is to be increased not less than 10%.

5.9.3 Astern Power

In determining the required size of gear, coupling and shafting transmitting astern power, the astern torque is to be considered when it exceeds the transmitted ahead torque. See also 4-1-1/7.5.

5.9.4 Quill Shafts

In the specific case of quill shafts subjected to small stress raisers and no bending moments, the least diameter may be determined by the following equation:

<i>SI units</i>	<i>MKS units</i>	<i>US units</i>
$d = 5.25 \cdot \sqrt[3]{bT}$	$d = 2.42 \cdot \sqrt[3]{bT}$	$d = 0.1 \cdot \sqrt[3]{bT}$
$b = 0.053 + \frac{187.8}{Y}$	$b = 0.053 + \frac{19.1}{Y}$	$b = 0.053 + \frac{27200}{Y}$

5.9.5 Shaft Couplings

For shaft couplings, coupling bolts, flexible coupling and clutches, see 4-3-2/5.19. For keys, see 4-3-2/5.7.

5.9.6 Vibration

The designer or builder is to evaluate:

- i) The shafting system for different modes of vibrations (torsional, axial, lateral) and their coupled effect, as appropriate,
- ii) The diameter of shafts considering maximum total torque (steady and vibratory torque),
- iii) The gears for gear chatter and harmful torsional vibrations stresses. See also 4-3-2/7.5.8.

5.9.7 Shrink Fitted Pinions and Wheels

For pinions and wheels shrink-fitted on shafts, preloading and stress calculations and fitting instructions are to be submitted for review. In general, the torsional holding capacity is to be at least 2.8 times the transmitted mean torque plus vibratory torque due to torsional vibration. For calculation purpose, to take account of torsional vibratory torque, the following factors may be applied to the transmitted torque, unless the actual measured vibratory torque is higher, in which case the actual vibratory torque is to be used.

- For direct diesel engine drives: 1.2
- For all other drives, including diesel engine drives with elastic couplings: 1.0

The preload stress based on the maximum available interference fit or maximum pull-up length is not to exceed 90% of the minimum specified yield strength.

The following friction coefficients are to be used:

- Oil injection method of fit: 0.13
- Dry method of fit: 0.18

5.9.8 Shrink Fitted Wheel Rim

For shrink-fitted wheel rims, preloading and stress calculations and fitting instructions are to be submitted for consideration. In general, the preloading stress based on the maximum interference fit or maximum pull-up length is not to exceed 90% of the minimum specified yield strength.

5.11 Rating of Cylindrical and Bevel Gears

The calculation procedures for the rating of external and internal involute spur and helical cylindrical gears having parallel axes and of bevel gears, with regard to surface durability (pitting) and tooth root bending strength, may be as given in Appendix 4-3-1A1. These procedures are in substantial agreement with ISO 6336 and ISO 10300 for cylinder and bevel gears, respectively.

5.13 Alternative Gear Rating Standards

Consideration will be given to gears that are rated based on any of the following alternative standards. In which case, gear rating calculations and justification of the applied gear design coefficients in accordance with the applicable design standard are to be submitted to ABS for review.

<i>Cylindrical Gears</i>	<i>Bevel Gears</i>
ANSI/AGMA 6032	AGMA 2003
ISO 6336	ISO 10300
DIN 3990, Part 31	DIN 3991

5.15 Gears with Multiple Prime Mover Inputs

For single helical gears with arrangements utilizing multiple prime mover inputs, and single or multiple outputs, the following analyses for all operating modes are to be conducted:

- All bearing reactions
- Tooth modifications
- Load distributions on the gear teeth
- Contact and tooth root bending stresses

A summary of the results of these analyses for each operating mode is to be submitted for review.

5.17 Rating of Gears for Intermittent Duty

5.17.1 Gears Intended for Intermittent Duty

Gears intended for intermittent duty are to have the conditions associated with the intermittent rating clearly defined and listed as part of the rating. These conditions include, but are not limited to, the specific intermittent rating (power and rpm) or ratings if there will be multiple intermittent ratings, the limit on the number of hours at the rating, both continuous per 24 hour period and total hours, the time between overhaul and servicing of the unit, and any other conditions that the manufacturer places on the unit.

5.17.2 Calculations

Calculations supporting the intermittent rating or ratings are to be submitted by the manufacturer to ABS for review. The calculations are to be based on ISO 6336-6 *Calculation of local capacity of spur and helical gears – Calculation of service life under variable load*, or an equivalent recognized national standard that uses a fatigue cycle approach.

7 Piping Systems for Gears

The requirements of piping systems essential for operation of gears for propulsion, maneuvering, electric power generation and vessel's safety are in Section 4-6-5 for diesel engine and gas turbine installations and in Section 4-6-6 for steam turbine installations. Additionally, requirements for hydraulic and pneumatic systems are provided in Section 4-6-7. Specifically, the following references are applicable:

Lubricating oil system:	4-6-5/5 and 4-6-6/9
Cooling system:	4-6-5/7 and 4-6-6/11
Hydraulic system:	4-6-7/3
Pneumatic system:	4-6-7/5
Piping system general requirements:	Section 4-6-1 and Section 4-6-2

9 Testing, Inspection and Certification of Gears

9.1 Material Tests

For testing of materials intended for gear construction, see 4-3-1/3.1 and 4-3-1/3.3.

9.3 Dynamic Balancing

Finished pinions and wheels are to be dynamically balanced in two planes where their pitch line velocity exceeds 25 m/s (4920 ft/min).

Where their pitch line velocity does not exceed 25 m/s (4920 ft/min) or where dynamic balance is impracticable due to size, weight, speed or construction of units, the parts may be statically balanced in a single plane.

The residual unbalance in each plane is not to exceed the value determined by the following equations:

<i>SI units</i>	<i>MKS units</i>	<i>US units</i>
$B = 24 \cdot W/N$	$B = 24000 \cdot W/N$	$B = 15.1 \cdot W/N$

where

- B = maximum allowable residual unbalance; N-mm (gf-mm, oz-in)
 W = weight of rotating part; N (kgf, lbf)
 N = rpm at rated speed

9.5 Shop Inspection

Each gear unit that requires to be certified by 4-3-1/1.1 is to be inspected during manufacture by a Surveyor for conformance with the approved design. This is to include but not limited to checks on gear teeth hardness, and surface finish and dimension checks of main load bearing components. The accuracy of meshing is to be verified for all meshes and the initial tooth contact pattern is to be checked by the Surveyor.

Reports on pinions and wheels balancing as per 4-3-1/9.3 are to be made available to the Surveyor for verification.

9.7 Certification of Gears

9.7.1 General

Each gear required to be certified by 4-3-1/1.1 is:

- i) To have its design approved by ABS; for which purpose, plans and data as required by 4-3-1/1.5 are to be submitted to ABS for approval.
- ii) To be surveyed during its construction, which is to include, but not limited to, material tests as indicated in 4-3-1/9.1, meshing accuracy and tooth contact pattern checks as indicated in 4-3-1/9.5, and verification of dynamic balancing as indicated in 4-3-1/9.3.

9.7.2 Approval Under the Type Approval Program

9.7.2(a) Product design assessment. Upon application by the manufacturer, each rating of a type of gear may be design assessed as described in 1-1-A3/5.1. For this purpose, each rating of a gear type is to be approved in accordance with 4-3-1/9.7.1i). The type test, however, is to be conducted in accordance with an approved test schedule and is to be witnessed by a Surveyor. Gear so approved may be applied to ABS for listing on the ABS website as Products Design Assessed. Once listed, and subject to renewal and updating of certificate as required by 1-1-A3/5.7, gear particulars will not be required to be submitted to ABS each time the gear is proposed for use onboard a vessel.

9.7.2(b) Mass produced gears. A manufacturer of mass-produced gears, who operates a quality assurance system in the manufacturing facilities, may apply to ABS for quality assurance assessment described in 1-1-A3/5.5 (PQA).

Upon satisfactory assessment under 1-1-A3/5.5 (PQA), gears produced in those facilities will not require a Surveyor's attendance at the tests and inspections indicated in 4-3-1/9.7.1ii). Such tests and inspections are to be carried out by the manufacturer whose quality control documents will be accepted. Certification of each gear will be based on verification of approval of the design and on continued effectiveness of the quality assurance system. See 1-1-A3/5.7.1(a).

9.7.2(c) Non-mass Produced Gears. A manufacturer of non-mass produced gears, who operates a quality assurance system in the manufacturing facilities, may apply to ABS for quality assurance assessment described in 1-1-A3/5.3.1(a) (AQS) or 1-1-A3/5.3.1(b) (RQS). Certification to 1-1-A3/5.5 (PQA) may also be considered in accordance with 4-1-1/Table 2.

9.7.2(d) Type Approval Program. Gear types which have their ratings approved in accordance with 4-3-1/9.7.2(a) and the quality assurance system of their manufacturing facilities approved in accordance with 4-3-1/9.7.2(b) or 4-3-1/9.7.2(c) will be deemed Type Approved and will be eligible for listing on the ABS website as Type Approved Product.

9.9 Shipboard Trials

After installation on board a vessel, the gear unit is to be operated in the presence of the Surveyor to demonstrate its ability to function satisfactorily under operating conditions and its freedom from harmful vibration at speeds within the operating range. When the propeller is driven through reduction gears, the Surveyor is to ascertain that no gear-tooth chatter occurs throughout the operating range; otherwise, a barred speed range, as specified in 4-3-2/7.5.3, is to be provided.

For conventional propulsion gear units above 1120 kW (1500 hp), a record of gear-tooth contact is to be made at the trials. To facilitate the survey of extent and uniformity of gear-tooth contact, selected bands of pinion or gear teeth on each meshing are to be coated beforehand with copper or layout dye. See also 7-6-2/1.1.2 for the first annual survey after the vessel enters service.

Post-trial examination of spur and helical type gears is to indicate essentially uniform contact across 90% of the effective face width of the gear teeth, excluding end relief.

The gear-tooth examination for spur and helical type gear units of 1120 kW (1500 hp) and below, all epicyclical gear units and bevel type gears will be subject to special consideration. The gear manufacturers' recommendations will be considered.

PART

4

CHAPTER 3 Propulsion and Maneuvering Machinery

SECTION 1 Appendix 1 – Rating of Cylindrical and Bevel Gears

1 Application

The following calculation procedures cover the rating of external and internal involute spur and helical cylindrical gears having parallel axis, and of bevel gears with regard to surface durability (pitting) and tooth root bending strength.

For normal working pressure angles in excess of 25° or helix angles in excess of 30°, the results obtained from these calculation procedures are to be confirmed by experience data which are to be submitted by the manufacturer.

The influence factors are defined regarding their physical interpretation. Some of the influence factors are determined by the gear geometry or have been established by conventions. These factors are to be calculated in accordance with the equations provided.

Other influence factors, which are approximations, and are indicated as such, may also be calculated according to appropriate alternative methods for which engineering justification is to be provided for verification.

3 Symbols and Units

The main symbols used are listed below. Symbols specifically introduced in connection with the definition of influence factors are described in the appropriate sections.

Units of calculations are given in the sequence of SI units (MKS units, and US units.)

a	center distance	mm (in.)
b	common facewidth	mm (in.)
b_1, b_2	facewidth of pinion, wheel	mm (in.)
b_{eH}	effective facewidth	mm (in.)
b_s	web thickness	mm (in.)
b_B	facewidth of one helix on a double helical gear	mm (in.)
d_1, d_2	reference diameter of pinion, wheel	mm (in.)
d_{a1}, d_{a2}	tip diameter of pinion, wheel (refer to 4-3-1A1/Figure 5)	mm (in.)
d_{b1}, d_{b2}	base diameter of pinion, wheel (refer to 4-3-1A1/Figure 5)	mm (in.)
d_{f1}, d_{f2}	root diameter of pinion, wheel (refer to 4-3-1A1/Figure 5)	mm (in.)
d_{i1}, d_{i2}	rim inside diameter of pinion, wheel (refer to 4-3-1A1/Figure 5)	mm (in.)
d_{sh}	external diameter of shaft	mm (in.)
d_{shi}	internal diameter of hollow shaft	mm (in.)
d_{w1}, d_{w2}	working pitch diameter of pinion, wheel	mm (in.)
f_{fa1}, f_{fa2}	profile form deviation of pinion, wheel	mm (in.)
f_{pb1}, f_{pb2}	transverse base pitch deviation of pinion, wheel	mm (in.)
h_1, h_2	tooth depth of pinion, wheel	mm (in.)
h_{a1}, h_{a2}	addendum of pinion, wheel	mm (in.)
h_{a01}, h_{a02}	addendum of tool of pinion, wheel	mm (in.)

h_{f1}, h_{f2}	dedendum of pinion, wheel	mm (in.)
h_{fp1}, h_{fp2}	dedendum of basic rack of pinion, wheel	mm (in.)
h_{F1}, h_{F2}	bending moment arm for tooth root bending stress for application of load at the outer point of single tooth pair contact for pinion, wheel	mm (in.)
l	bearing span	mm (in.)
l_b	length of contact	mm (in.)
m_n	normal module	mm (in.)
m_{na}	outer normal module	mm (in.)
m_t	transverse module	mm (in.)
n_1, n_2	rotational speed of pinion, wheel	rpm
p_d	outer diametral pitch	mm ⁻¹ (in ⁻¹)
p_{r01}, p_{r02}	protuberance of tool for pinion, wheel	mm (in.)
q_1, q_2	machining allowance of pinion, wheel	mm (in.)
s_{Fn1}, s_{Fn2}	tooth root chord in the critical section of pinion, wheel	mm (in.)
s	distance between mid-plane of pinion and the middle of the bearing span	mm (in.)
u	gear ratio	---
v	tangential speed at reference diameter	m/s (m/s, ft/min)
x_1, x_2	addendum modification coefficient of pinion, wheel	---
x_{sm}	tooth thickness modification coefficient (midface)	---
z_1, z_2	number of teeth of pinion, wheel	---
z_{n1}, z_{n2}	virtual number of teeth of pinion, wheel	---
B	total facewidth, of double helical gear including gap width	mm (in.)
F_{bt}	nominal tangential load on base cylinder in the transverse section	N (kgf, lbf)
F_t	nominal transverse tangential load at reference cylinder	N (kgf, lbf)
P	transmitted rated power	kW (mhp, hp)
Q	ISO grade of accuracy	-
R	cone distance	mm (in.)
R_m	middle cone distance	mm (in.)
R_{zf1}, R_{zf2}	flank roughness of pinion, wheel	μm (μin.)
R_{zr1}, R_{zr2}	fillet roughness of pinion, wheel	μm (μin.)
T_1, T_2	nominal torque of pinion, wheel	N-m (kgf-m, lbf-ft)
U	minimum ultimate tensile strength of core (applicable to through hardened, normalized and cast gears only)	N/mm ² (kgf/mm ² , lbf/in ²)
$\alpha_{en1}, \alpha_{en2}$	form-factor pressure angle: pressure angle at the outer point of single pair tooth contact for pinion, wheel	degrees
$\alpha_{Fen1}, \alpha_{Fen2}$	load direction angle: relevant to direction of application of load at the outer point of single pair tooth contact of pinion, wheel	degrees
α_n	normal pressure angle at reference cylinder	degrees
α_t	transverse pressure angle at reference cylinder	degrees
α_{vt}	transverse pressure angle of virtual cylindrical gear	degrees
α_{vt}	transverse pressure angle at working pitch cylinder	degrees
β	helix angle at reference cylinder	degrees
β_b	helix angle at base cylinder	degrees
β_{vb}	helix angle at base circle	degrees
δ_1, δ_2	reference cone angle of pinion, wheel	degrees
δ_{a1}, δ_{a2}	tip angle of pinion, wheel	degrees
ε_α	transverse contact ratio	---
ε_β	overlap ratio	---
ε_γ	total contact ratio	---
ρ_{a01}, ρ_{a02}	tip radius of tool of pinion, wheel	mm (in.)
ρ_c	radius of curvature at pitch surface	mm (in.)
ρ_{fp}	root radius of basic rack	mm (in.)
ρ_{F1}, ρ_{F2}	root fillet radius at the critical section of pinion, wheel	mm (in.)
Subscripts	1 = pinion; 2 = wheel; 0 = tool	

5 Geometrical Definitions

For internal gearing z_2 , a , d_2 , d_{a2} , d_{b2} , d_{w2} and u are negative.

The pinion is defined as the gear with the smaller number of teeth. Therefore the absolute value of the gear ratio, defined as follows, is always greater or equal to the unity:

$$u = z_2/z_1 = d_{w2}/d_{w1} = d_2/d_1$$

In the equation of surface durability, b is the common facewidth on the pitch diameter.

In the equation of tooth root bending stress, b_1 or b_2 are the facewidths at the respective tooth roots. In any case, b_1 and b_2 are not to be taken as greater than b by more than one normal module m_n on either side.

The common facewidth b may be used also in the equation of teeth root bending stress if significant crowning or end relief have been applied.

Additional geometrical definitions are given in the following expressions.

$$\tan \alpha_t = \tan \alpha_n / \cos \beta$$

$$\tan \beta_b = \tan \beta \cdot \cos \alpha_t$$

$$d_{1,2} = z_{1,2} \cdot m_n / \cos \beta$$

$$d_{b1,2} = d_{1,2} \cdot \cos \alpha_t = d_{w1,2} \cdot \cos \alpha_{tw}$$

$$a = 0.5(d_{w1} + d_{w2})$$

$$z_{n1,2} = z_{1,2} / (\cos^2 \beta_b \cdot \cos \beta)$$

$$m_t = m_n / \cos \beta$$

$$\text{inv } \alpha = \tan \alpha - \pi \cdot \alpha / 180, \alpha \text{ in degrees}$$

$$\text{inv } \alpha_{wt} = \text{inv } \alpha_t + 2 \cdot \tan \alpha_n \cdot \frac{(x_1 + x_2)}{(z_1 + z_2)}$$

$$\alpha_{wt} = \arccos \left(\frac{d_{b1} + d_{b2}}{2 \cdot a} \right), \alpha_{wt} \text{ in degrees}$$

$$x_1 + x_2 = \frac{(z_1 + z_2) \cdot (\text{inv } \alpha_{wt} - \text{inv } \alpha_t)}{2 \cdot \tan \alpha_n}$$

$$x_1 = \frac{h_{a0}}{m_n} - \frac{d_1 - d_{f1}}{2 \cdot m_n}, x_2 = \frac{h_{a0}}{m_n} - \frac{d_2 - d_{f2}}{2 \cdot m_n}$$

$$\varepsilon_\alpha = \frac{0.5 \cdot \sqrt{d_{a1}^2 - d_{b1}^2} \pm 0.5 \cdot \sqrt{d_{a2}^2 - d_{b2}^2} - a \cdot \sin \alpha_{wt}}{\pi \cdot m_n \cdot \frac{\cos \alpha_t}{\cos \beta}}$$

(The positive sign is to be used for external gears; the negative sign for internal gears.)

$$\varepsilon_\beta = \frac{b \cdot \sin \beta}{\pi \cdot m_n}$$

(For double helix, b is to be taken as the width of one helix.)

$$\varepsilon_\gamma = \varepsilon_\alpha + \varepsilon_\beta$$

$$\rho_c = \frac{a \cdot \sin \alpha_{wt} \cdot u}{\pi \cdot m_n}$$

$$v = d_{1,2} \cdot n_{1,2} / 19099 \quad [\text{SI and MKS units}]$$

$$v = d_{1,2} \cdot n_{1,2} / 3.82 \quad [\text{US units}]$$

7 Bevel Gear Conversion and Specific Formulas

Conversion of bevel gears to virtual (equivalent) cylindrical gears is based on the bevel gear midsection.

Index v refers to the virtual (equivalent) cylindrical gear.

Index m refers to the midsection of bevel gear.

δ_1, δ_2	=	pitch angle pinion, wheel
δ_{a1}, δ_{a2}	=	face angle pinion, wheel
Σ	=	shaft angle
β_m	=	mean spiral angle
$d_{e1,2}$	=	outer pitch diameter pinion, wheel
$d_{m1,2}$	=	mean pitch diameter pinion, wheel
$d_{v1,2}$	=	reference diameter of virtual cylindrical gear pinion, wheel
$R_{e1,2}$	=	outer cone distance pinion, wheel
R_m	=	mean cone distance

Number of teeth of virtual cylindrical gear:

$$z_{v1} = \frac{z_1}{\cos \delta_1}$$

$$z_{v2} = \frac{z_2}{\cos \delta_2}$$

- For $\Sigma = 90^\circ$:

$$z_{v1} = z_1 \frac{\sqrt{u^2 + 1}}{u}$$

$$z_{v2} = z_2 \sqrt{u^2 + 1}$$

Gear ratio of virtual cylindrical gear:

$$u_v = \frac{z_{v2}}{z_{v1}}$$

- For $\Sigma = 90^\circ$:

$$u_v = u^2$$

Geometrical definitions:

$$\delta_1 + \delta_2 = \Sigma$$

$$\tan \alpha_{vt} = \frac{\tan \alpha_n}{\cos \beta_m}$$

$$\tan \beta_{bm} = \tan \beta_m \cdot \cos \alpha_{vt}$$

$$\beta_{vb} = \arcsin(\sin \beta_m \cdot \cos \alpha_n)$$

$$R_e = \frac{d_{e1,2}}{2 \cdot \sin \delta_{1,2}}$$

$$R_m = R_e - \frac{b}{2}, \quad b \leq \frac{R}{3}$$

Reference diameter of pinion, wheel refers to the midsection of the bevel gear:

$$d_{m1} = d_{e1} - b \cdot \sin \delta_1$$

$$d_{m2} = d_{e2} - b \cdot \sin \delta_2$$

Modules:

Outer transverse module:

$$m_{et} = \frac{d_{e2}}{z_2} = \frac{d_{e1}}{z_1} = \frac{25.4}{P_d}$$

Outer normal module:

$$m_{na} = m_t \cdot \cos \beta_m$$

Mean normal module:

$$m_{mn} = m_{mt} \cdot \cos \beta_m$$

$$m_{mn} = m_{et} \cdot \frac{R_m}{R_e} \cdot \cos \beta_m$$

$$m_{mn} = \frac{d_{m1}}{z_1} \cdot \cos \beta_m$$

$$m_{mn} = \frac{d_{m2}}{z_2} \cdot \cos \beta_m$$

Base pitch:

$$P_{btm} = \frac{\pi \cdot m_{mn} \cdot \cos \alpha_{vt}}{\cos \beta_m}$$

Reference diameter of pinion, wheel refers to the virtual (equivalent) cylindrical gear:

$$d_{v1} = \frac{d_{m1}}{\cos \delta_1}$$

$$d_{v2} = \frac{d_{m2}}{\cos \delta_2}$$

Base diameter of pinion, wheel:

$$d_{vb1} = d_{v1} \cdot \cos \alpha_{vt}$$

$$d_{vb2} = d_{v2} \cdot \cos \alpha_{vt}$$

Center distance of virtual cylindrical gear:

$$a_v = 0.5 \cdot (d_{v1} + d_{v2})$$

Transverse pressure angle of virtual cylindrical gear:

$$\alpha_{vt} = \arccos \left(\frac{d_{vb1} + d_{vb2}}{2 \cdot a_v} \right), \alpha_{vt} \text{ in degrees}$$

Mean Addendum:

For gears with constant addendum *Zyklo-Palloid (Klingelberg)*:

$$h_{am1} = m_{mn} \cdot (1 + x_{hm1})$$

$$h_{am2} = m_{mn} \cdot (1 + x_{hm2})$$

For gears with variable addendum (*Gleason*):

$$h_{am1} = h_{ae1} - \frac{b}{2} \cdot \tan(\delta_{a1} - \delta_1)$$

$$h_{am2} = h_{ae2} - \frac{b}{2} \cdot \tan(\delta_{a2} - \delta_2)$$

where h_{ae} is the outer addendum.

Profile shift coefficients:

$$x_{hm1} = \frac{h_{am1} - h_{am2}}{2 \cdot m_{mn}}$$

$$x_{hm2} = \frac{h_{am2} - h_{am1}}{2 \cdot m_{mn}}$$

Mean Dedendum:

For gears with constant dedendum *Zyklo-Palloid (Klingelberg)*:

$$h_{fp} = (1.25 \dots 1.30) \cdot m_{mn}$$

$$\rho_{fp} = (0.2 \dots 0.3) \cdot m_{mn}$$

For gears with variable dedendum (*Gleason*):

$$h_{fm1} = h_{fe1} - \frac{b}{2} \cdot \tan(\delta_{a1} - \delta_1)$$

$$h_{fm2} = h_{fe2} - \frac{b}{2} \cdot \tan(\delta_{a2} - \delta_2)$$

$$h_{f1} = h_{fm1} + x_{hm1} \cdot m_{mn}$$

$$h_{f2} = h_{fm2} + x_{hm2} \cdot m_{mn}$$

where h_{fe} is the outer dedendum and h_{fm} is the mean dedendum.

Tip diameter of pinion, wheel:

$$d_{va1} = d_{v1} + 2 \cdot h_{am1}$$

$$d_{va2} = d_{v2} + 2 \cdot h_{am2}$$

Transverse contact ratio:

$$\varepsilon_{v\alpha} = \frac{0.5 \cdot \sqrt{d_{va1}^2 - d_{vb1}^2} + 0.5 \cdot \sqrt{d_{va2}^2 - d_{vb2}^2} - a_v \cdot \sin a_{vt}}{\pi \cdot m_{mn} \cdot \frac{\cos a_{vt}}{\cos \beta_m}}$$

Overlap ratio:

$$\varepsilon_{v\beta} = \frac{b \cdot \sin \beta_m}{\pi \cdot m_{mn}}$$

Modified contact ratio:

$$\varepsilon_{vy} = \sqrt{\varepsilon_{v\alpha}^2 + \varepsilon_{v\beta}^2}$$

Tangential speed at midsection:

$$v_{mt} = \frac{d_{m1,2} \cdot n_{1,2}}{19098} \quad \text{m/s} \quad [\text{SI and MKS units}]$$

$$v_{mt} = \frac{d_{m1,2} \cdot n_{1,2}}{3.82} \quad \text{ft/min} \quad [\text{US units}]$$

Radius of curvature (normal section):

$$\rho_{vc} = \frac{a_v \cdot \sin \alpha_{vt}}{\cos \beta_{bm}} \cdot \frac{u_v}{(1 + u_v)^2}$$

Length of the middle line of contact:

$$\ell_{bm} = \frac{b \cdot \varepsilon_{v\alpha}}{\cos \beta_{vb}} \cdot \frac{\sqrt{\varepsilon_{vy}^2 - [(2 - \varepsilon_{v\alpha}) \cdot (1 - \varepsilon_{v\beta})]^2}}{\varepsilon_{vy}^2} \quad \text{for } \varepsilon_{v\beta} < 1$$

$$\ell_{bm} = \frac{b \cdot \varepsilon_{v\alpha}}{\varepsilon_{vy} \cdot \cos \beta_{vb}} \quad \text{for } \varepsilon_{v\beta} \geq 1$$

9 Nominal Tangential Load, F_t , F_{mt}

The nominal tangential load, F_t or F_{mt} , tangential to the reference cylinder and perpendicular to the relevant axial plane, is calculated directly from the rated power transmitted by the gear by means of the following equations:

	<i>SI units</i>	<i>MKS units</i>	<i>US units</i>
	$T_{1,2} = 9549 \cdot P/n_{1,2}$ N-m	$T_{1,2} = 716.2 \cdot P/n_{1,2}$ kgf-m	$T_{1,2} = 5252 \cdot P/n_{1,2}$ lbf-ft
Cylindrical gears	$F_t = \frac{2000T_{1,2}}{d_{1,2}} = \frac{19.1P \times 10^6}{n_{1,2}d_{1,2}}$ N	$F_t = \frac{2000T_{1,2}}{d_{1,2}} = \frac{1.4325P \times 10^6}{n_{1,2}d_{1,2}}$ kgf	$F_t = \frac{24T_{1,2}}{d_{1,2}} = \frac{126.05P \times 10^3}{n_{1,2}d_{1,2}}$ lbf
Bevel gears	$F_{mt} = \frac{2000T_{1,2}}{d_{m1,2}} = \frac{19.1P \times 10^6}{n_{1,2}d_{m1,2}}$ N	$F_{mt} = \frac{2000T_{1,2}}{d_{m1,2}} = \frac{1.4325P \times 10^6}{n_{1,2}d_{m1,2}}$ kgf	$F_{mt} = \frac{24T_{1,2}}{d_{m1,2}} = \frac{126.05P \times 10^3}{n_{1,2}d_{m1,2}}$ lbf

Where the vessel on which the gear unit is being used, is receiving an **Ice Class** notation, see 6-1-5/55 or 6-1-6/27.

11 Application Factor, K_A

The application factor, K_A , accounts for dynamic overloads from sources external to the gearing.

The application factor, K_A , for gears designed for infinite life, is defined as the ratio between the maximum repetitive cyclic torque applied to the gear set and the nominal rated torque.

The factor mainly depends on:

- Characteristics of driving and driven machines;
- Ratio of masses;
- Type of couplings;
- Operating conditions as e.g., overspeeds, changes in propeller load conditions.

When operating near a critical speed of the drive system, a careful analysis of these conditions must be made.

The application factor, K_A , should be determined by measurements or by appropriate system analysis. Where a value determined in such a way cannot be provided, the following values are to be used:

a) *Main propulsion gears:*

Turbine and electric drive:	1.00
Diesel engine with hydraulic or electromagnetic slip coupling:	1.00
Diesel engine with high elasticity coupling:	1.30
Diesel engine with other couplings:	1.50

b) *Auxiliary gears:*

Electric motor, diesel engine with hydraulic or electromagnetic slip coupling:	1.00
Diesel engine with high elasticity coupling:	1.20
Diesel engine with other couplings:	1.40

13 Load Sharing Factor, K_γ

The load sharing factor K_γ accounts for the maldistribution of load in multiple path transmissions as e.g., dual tandem, epicyclical, double helix.

The load sharing factor K_γ is defined as the ratio between the maximum load through an actual path and the evenly shared load. The factor mainly depends on accuracy and flexibility of the branches.

The load sharing factor K_γ should be determined by measurements or by appropriate system analysis. Where a value determined in such a way cannot be provided, the following values are to be used:

a) *Epicyclical gears:*

Up to 3 planetary gears:	1.00
4 planetary gears:	1.20
5 planetary gears:	1.30
6 planetary gears and over:	1.40

b) *Other gear arrangements including bevel gears:* 1.00

15 Dynamic Factor, K_v

The dynamic factor, K_v , accounts for internally generated dynamic loads due to vibrations of pinion and wheel against each other.

The dynamic factor, K_v , is defined as the ratio between the maximum load which dynamically acts on the tooth flanks and the maximum externally applied load ($F_t \cdot K_A \cdot K_\gamma$).

The factor mainly depends on:

- Transmission errors (depending on pitch and profile errors)
- Masses of pinion and wheel

- Gear mesh stiffness variation as the gear teeth pass through the meshing cycle
- Transmitted load including application factor
- Pitch line velocity
- Dynamic unbalance of gears and shaft
- Shaft and bearing stiffnesses
- Damping characteristics of the gear system

The dynamic factor, K_v , is to be advised by the manufacturer as supported by his measurements, analysis or experience data or is to be determined as per 4-3-1A1/15.1, except that where $v z_1/100$ is 3 m/s (590 ft/min.) or above, K_v may be obtained from Appendix 4-3-1A1/15.3.

15.1 Determination of K_v – Simplified Method

Where all of the following four conditions are satisfied, K_v may be determined in accordance with Appendix 4-3-1A1/15.1.

- a) Steel gears of heavy rims sections.
 b) Values of F_t/b are in accordance with the following table:

SI units	MKS units	US units
> 150 N/mm	> 15 kgf/mm	> 856 lbf/in

- c) $z_1 < 50$

- d) Running speeds in the subcritical range are in accordance with the following table:

	$(v \cdot z_1) / 100$	
	SI & MKS units	US units
Helical gears	< 14 m/s	< 2756 ft/min
Spur gears	< 10 m/s	< 1968 ft/min
All types of gears	< 3 m/s	< 590 ft/min

For gears other than specified above, the single resonance method, as per 4-3-1A1/15.3 below, may be applied.

The methods of calculation are as follows:

	SI and MKS units	US units
For helical gears of overlap ratio $\varepsilon_\beta \geq \text{unity}$	$K_v = K_{vh} = 1 + K_1 \cdot v \cdot z_1/100$	$K_v = K_{vh} = 1 + K_1 \cdot v \cdot z_1/19685$
For helical gears of overlap ratio $\varepsilon_\beta < \text{unity}$	K_v is obtained by means of linear interpolation: $K_v = K_{vs} - \varepsilon_\beta(K_{vs} - K_{vh})$	
For spur gears	$K_v = K_{vs} = 1 + K_1 \cdot v \cdot z_1/100$	$K_v = K_{vs} = 1 + K_1 \cdot v \cdot z_1/19685$
For bevel gears	In the above conditions (b, c and d) and in the above formulas: <ul style="list-style-type: none"> • the real z_1 is to be used instead of the virtual (equivalent) z_{v1}; • v is to be substituted by v_{mt}; (tangential speed at midsection); and • F_t is to be substituted by F_{mr}. 	
For all gears	K_1 values are specified in table below.	

	K_1 for different values of Q (ISO Grades of accuracy)					
	3	4	5	6	7	8
Spur gears	0.0220	0.0300	0.0430	0.0620	0.0920	0.1250
Helical gears	0.0125	0.0165	0.0230	0.0330	0.0480	0.0700

Q is to be according to ISO 1328. In case of mating gears with different grades of accuracy, the grade corresponding to the lower accuracy should be used.

15.3 Determination of K_v – Single Resonance Method

For single stage gears, the dynamic factor K_v may be determined from 4-3-1A1/15.3.3 through 4-3-1A1/15.3.6 for the ratio N in 4-3-1A1/15.3.1 and using the factors given in 4-3-1A1/15.3.2.

15.3.1 Resonance Ratio, N

$$N = \frac{n_1}{n_{E1}}$$

$$n_{E1} = \frac{30 \times 10^3}{\pi \cdot z_1} \cdot \sqrt{\frac{C_\gamma}{m_{red}}} \quad \text{rpm} \quad [\text{SI units}]$$

$$n_{E1} = \frac{93.947 \times 10^3}{\pi \cdot z_1} \cdot \sqrt{\frac{C_\gamma}{m_{red}}} \quad \text{rpm} \quad [\text{MKS units}]$$

$$n_{E1} = \frac{589.474 \times 10^3}{\pi \cdot z_1} \cdot \sqrt{\frac{C_\gamma}{m_{red}}} \quad \text{rpm} \quad [\text{US units}]$$

where:

m_{red} = relative reduced mass of the gear pair, per unit facewidth referred to the line of action:

$$m_{red} = \frac{\pi}{8} \cdot \left(\frac{d_{m1}}{d_{b1}} \right)^2 \cdot \left[\frac{d_{m1}^2}{(1/(1-q_1^4) \cdot \rho_1) + (1/(1-q_2^4) \cdot \rho_2 \cdot u^2)} \right] \quad \text{kg/mm (lb/in)}$$

$$m_{red} = \frac{J_1 \cdot J_2}{p \cdot J_1 \cdot \left(\frac{d_{b2}}{2} \right)^2 + J_2 \cdot \left(\frac{d_{b1}}{2} \right)^2} \quad \text{kg/mm (lb/in)}$$

p = for planetary gears, number of planets

$$d_{m1, m2} = \frac{d_{a1,a2} + d_{f1,f2}}{2} \quad \text{mm (in.)}$$

$$q_1 = \frac{d_{i1}}{d_{m1}}; \quad q_2 = \frac{d_{i2}}{d_{m2}} \quad \text{for reference, see 4-3-1A1/Figure 5}$$

J_1 = moment of inertia per unit facewidth for pinion:

$$J_1 = \frac{\pi \cdot \rho_1 \cdot d_{b1}^4}{32} \quad \text{kg-mm}^2/\text{mm (lb-in}^2/\text{in)}$$

J_2 = moment of inertia per unit facewidth for wheel:

$$J_2 = \frac{\pi \cdot \rho_2 \cdot d_{b2}^4}{32} \quad \text{kg-mm}^2/\text{mm (lb-in}^2/\text{in)}$$

$$\begin{aligned} \rho_{1,2} &= \text{density of pinion, wheel materials} \\ \rho &= \text{density of steel material:} \\ &= 7.83 \times 10^{-6} \quad \text{kg/mm}^3 \quad [\text{SI and MKS units}] \\ &= 2.83 \times 10^{-1} \quad \text{lb/in}^3 \quad [\text{US units}] \end{aligned}$$

Bevel gears:

For bevel gears, the real z_1 (not the equivalent) should be inserted in the above formulas. Determination of m_{red} is to be as follows:

$$\begin{aligned} m_{1,2}^* &= \frac{\pi}{8} \cdot \rho_{1,2} \cdot \left[\frac{d_{m1,2}^2}{\cos^2 \alpha_n} \right] \quad \text{kg/mm (lb/in.)} \\ m_{red} &= \frac{m_1^* \cdot m_2^*}{m_1^* + m_2^*} \quad \text{kg/mm (lb/in.)} \end{aligned}$$

Mesh stiffness per unit facewidth, C_γ :

$$\begin{aligned} C_\gamma &= \frac{20}{0.85} \cdot B_b \quad \text{N/mm-}\mu\text{m} \quad [\text{SI units}] \\ C_\gamma &= \frac{2.039}{0.85} \cdot B_b \quad \text{kgf/mm-}\mu\text{m} \quad [\text{MKS units}] \\ C_\gamma &= \frac{2.901}{0.85} \cdot B_b \quad \text{lbf/in-}\mu\text{in} \quad [\text{US units}] \end{aligned}$$

Tooth stiffness of one pair of teeth per unit facewidth (single stiffness), c' :

$$\begin{aligned} c' &= \frac{14}{0.85} \cdot B_b \quad \text{N/mm-}\mu\text{m} \quad [\text{SI units}] \\ c' &= \frac{1.428}{0.85} \cdot B_b \quad \text{kgf/mm-}\mu\text{m} \quad [\text{MKS units}] \\ c' &= \frac{2.031}{0.85} \cdot B_b \quad \text{lbf/in-}\mu\text{in} \quad [\text{US units}] \end{aligned}$$

For a combination of different materials for pinion and wheel, c' is to be multiplied by ξ , where

$$\begin{aligned} \xi &= \frac{E}{E_{st}} \\ E &= \frac{2E_1E_2}{E_1 + E_2} \quad \text{where values of } E_1 \text{ and } E_2 \text{ are to be obtained from 4-3-1A1/Table 1} \\ E_{st} &= \text{Young's modulus of steel; see 4-3-1A1/Table 1} \end{aligned}$$

Overall facewidth, B_b :

$$B_b = \frac{b_{eH}}{b}$$

where: b_{eH} = effective facewidth, mm (in.)

Note: Higher values than $B_b = 0.85$ are not to be used.

Cylindrical gears:

Mesh stiffness per unit facewidth, C_γ :

$$C_\gamma = c' \cdot (0.75 \cdot \varepsilon_\alpha + 0.25) \quad \text{N/mm-}\mu\text{m (kgf/mm-}\mu\text{m, lbf/in-}\mu\text{in)}$$

Tooth stiffness of one pair of teeth per unit facewidth (single stiffness), c' :

$$c' = 0.8 \cdot \frac{\cos \beta}{q'} \cdot C_{BS} \cdot C_R \quad \text{N/mm-}\mu\text{m} \quad [\text{SI units}]$$

$$c' = 8.158 \cdot 10^{-2} \cdot \frac{\cos \beta}{q'} \cdot C_{BS} \cdot C_R \quad \text{kgf/mm-}\mu\text{m} \quad [\text{MKS units}]$$

$$c' = 11.603 \cdot 10^{-2} \cdot \frac{\cos \beta}{q'} \cdot C_{BS} \cdot C_R \quad \text{lbf/in-}\mu\text{in} \quad [\text{US units}]$$

For a combination of different materials for pinion and wheel, c' is to be multiplied by ξ , where

$$\xi = \frac{E}{E_{st}}$$

$$E = \frac{2 \cdot E_1 \cdot E_2}{E_1 + E_2} \quad \text{where values of } E_1 \text{ and } E_2 \text{ are to be obtained from 4-3-1A1/Table 1}$$

E_{st} = Young's modulus of steel; see 4-3-1A1/Table 1

$$q' = 0.04723 + \frac{0.15551}{z_{n1}} + \frac{0.25791}{z_{n2}} - 0.00635 \cdot x_1 - \frac{0.11654 \cdot x_1}{z_{n1}} - 0.00193 \cdot x_2 - \frac{0.24188 \cdot x_2}{z_{n2}} + 0.00529 \cdot x_1^2 + 0.00182 \cdot x_2^2$$

$$z_{n1} = \frac{z_1}{\cos^2 \beta_b \cdot \cos \beta}$$

$$z_{n2} = \frac{z_2}{\cos^2 \beta_b \cdot \cos \beta}$$

Note: For internal gears, use z_{n2} ($= \infty$) equal infinite and $x_2 = 0$.

$$C_{BS} = \left[1 + 0.5 \cdot \left(1.2 - \frac{h_{fp}}{m_n} \right) \right] \cdot [1 - 0.02 \cdot (20 - \alpha_n)]$$

When the pinion basic rack dedendum is different from that of the wheel, the arithmetic mean of C_{BS1} for a gear pair conjugate to the pinion basic rack and C_{BS2} for a gear pair conjugate to the basic rack of the wheel:

$$C_{BS} = 0.5 \cdot (C_{BS1} + C_{BS2})$$

Gear blank factor, C_R :

$$C_R = 1 + \frac{\ln(b_s / b)}{5 \cdot e^{(s_R / 5 \cdot m_n)}}$$

when: 1) $b_s / b < 0.2$, use 0.2 for b_s / b

2) $b_s / b > 1.2$, use 1.2 for b_s / b

3) $s_R / m_n < 1$, use 1.0 for s_R / m_n

For b_s and s_R see 4-3-1A1/Figure 3.

15.3.2 Factors B_p , B_j , and B_k

a) Values for f_{pt} and y_a according to ISO grades of accuracy Q :

$Q^{(1)}$		3	4 ⁽³⁾	5	6	7	8	9	10	11 ⁽⁴⁾	12
f_{pt}	μm	3	6	12	25	45	70	100	150	201	282
	μin	118	236	472	984	1772	2756	3937	5906	7913	11102
$y_a^{(2)}$	μm	0	0.5	1.5	4	7	15	25	40	55	75
	μin	0	19.7	59.1	157	276	591	984	1575	2165	2953

Notes

- 1 ISO grades of accuracy according to ISO 1328. In case of mating gears with different grades of accuracy, the grade corresponding to the lower accuracy should be used.
- 2 For specific determination of y_a , see b) through d) below.
- 3 Hardened nitrided.
- 4 Tempered normalized.

b) Determination of y_a for structural steels, through hardened steels and nodular cast iron (perlite, bainite):

<i>SI units</i>	<i>MKS units</i>	<i>US units</i>
$y_a = \frac{160}{\sigma_{Hlim}} \cdot f_{pb}$	$y_a = \frac{16.315}{\sigma_{Hlim}} \cdot f_{pb}$	$y_a = \frac{2.331 \times 10^4}{\sigma_{Hlim}} \cdot f_{pb}$
For $v \leq 5$ m/s: no restriction	For $v \leq 5$ m/s: no restriction	For $v \leq 984$ ft/min: no restriction
For $5 \text{ m/s} < v \leq 10 \text{ m/s}$: $y_{amax} = \frac{12800}{\sigma_{Hlim}}$ and $f_{pbmax} = 80 \mu\text{m}$	For $5 \text{ m/s} < v \leq 10 \text{ m/s}$: $y_{amax} = \frac{1.305 \times 10^3}{\sigma_{Hlim}}$ and $f_{pbmax} = 80 \mu\text{m}$	For $984 \text{ ft/min} < v \leq 1968 \text{ ft/min}$: $y_{amax} = \frac{7.341 \times 10^7}{\sigma_{Hlim}}$ and $f_{pbmax} = 3150 \mu\text{in}$
For $v > 10$ m/s: $y_{amax} = \frac{6400}{\sigma_{Hlim}}$ and $f_{pbmax} = 40 \mu\text{m}$	For $v > 10$ m/s: $y_{amax} = \frac{652.618}{\sigma_{Hlim}}$ and $f_{pbmax} = 40 \mu\text{m}$	For $v > 1968$ ft/min: $y_{amax} = \frac{3.67 \times 10^7}{\sigma_{Hlim}}$ and $f_{pbmax} = 1575 \mu\text{in}$

c) Determination of y_a for gray cast iron and nodular cast iron (ferritic):

<i>SI and MKS units</i>	<i>US units</i>
$y_a = 0.275 \cdot f_{pb} \mu\text{m}$	$y_a = 0.275 \cdot f_{pb} \mu\text{in}$
For $v \leq 5$ m/s: no restriction	For $v \leq 984$ ft/min: no restriction
For $5 \text{ m/s} < v \leq 10 \text{ m/s}$: $y_{amax} = 22$ and $f_{pbmax} = 80 \mu\text{m}$	For $984 \text{ ft/min} < v \leq 1968 \text{ ft/min}$: $y_{amax} = 866$ and $f_{pbmax} = 3150 \mu\text{in}$
For $v > 10$ m/s : $y_{amax} = 11$ and $f_{pbmax} = 40 \mu\text{m}$	For $v > 1968$ ft/min $y_{amax} = 433$ and $f_{pbmax} = 1575 \mu\text{in}$

d) Determination of y_a for case hardened, nitrided or nitrocarburized steels:

<i>SI and MKS units</i>	<i>US units</i>
$y_a = 0.075 \cdot f_{pb} \mu\text{m}$	$y_a = 0.075 \cdot f_{pb} \mu\text{in}$
For all velocities but with the restriction: $y_{amax} = 3$ and $f_{pbmax} = 40 \mu\text{m}$	For all velocities but with the restriction: $y_{amax} = 118$ and $f_{pbmax} = 1575 \mu\text{in}$

When the material of pinion differs from that of the wheel, y_{a1} for pinion and y_{a2} for wheel are to be determined separately. The mean value:

$$y_a = 0.5(y_{a1} + y_{a2})$$

is to be used for the calculation.

For bevel gears, f_{pt} is substituted for f_{pb} when determining y_a in b), c) and d).

e) Determination of factors B_p , B_f , B_k

$$B_p = \frac{c' \cdot f_{pbeff} \cdot b}{F_t \cdot K_A \cdot K_\gamma}$$

$$B_f = \frac{c' \cdot f_{feff} \cdot b}{F_t \cdot K_A \cdot K_\gamma}$$

where

$$f_{pbeff} = f_{pb} - y_a \quad \mu\text{m} (\mu\text{in})$$

$$f_{feff} = f_{fa} - y_f \quad \mu\text{m} (\mu\text{in})$$

$$f_{pb} = f_{pt} \cdot \cos \alpha_t \quad \mu\text{m} (\mu\text{in})$$

y_f can be determined in the same way as y_a when the profile deviation f_{fa} is used instead of the base pitch deviation f_{pb} .

$$B_k = \left| 1 - \frac{C_a}{C_{eff}} \right|$$

where:

SI units [μm]	MKS units [μm]	US units [μin]
$C_a = \frac{1}{18} \cdot \left(\frac{\sigma_{Hlim}}{97} - 18.45 \right)^2 + 1.5$	$C_a = \frac{1}{18} \cdot \left(\frac{\sigma_{Hlim}}{9.891} - 18.45 \right)^2 + 1.5$	$C_a = \frac{1}{0.457} \cdot \left(\frac{\sigma_{Hlim}}{1.407 \times 10^4} - 18.45 \right)^2 + 59$

When the materials differ, C_{a1} should be determined for the pinion material and C_{a2} for the wheel material using the following equations. The average value $C_a = \frac{C_{a1} + C_{a2}}{2}$ is used for the calculation.

$C_{a1} = \frac{1}{18} \cdot \left(\frac{\sigma_{Hlim1}}{97} - 18.45 \right)^2 + 1.5$	$C_{a1} = \frac{1}{18} \cdot \left(\frac{\sigma_{Hlim1}}{9.891} - 18.45 \right)^2 + 1.5$	$C_{a1} = \frac{1}{0.457} \cdot \left(\frac{\sigma_{Hlim1}}{1.407 \times 10^4} - 18.45 \right)^2 + 59$
$C_{a2} = \frac{1}{18} \cdot \left(\frac{\sigma_{Hlim2}}{97} - 18.45 \right)^2 + 1.5$	$C_{a2} = \frac{1}{18} \cdot \left(\frac{\sigma_{Hlim2}}{9.891} - 18.45 \right)^2 + 1.5$	$C_{a2} = \frac{1}{0.457} \cdot \left(\frac{\sigma_{Hlim2}}{1.407 \times 10^4} - 18.45 \right)^2 + 59$

For cylindrical gears:

$$C_{eff} = \frac{F_t \cdot K_A \cdot K_\gamma}{b \cdot c'} \quad \mu\text{m} (\mu\text{in})$$

For bevel gears:

$$C_{eff} = \frac{F_{mbt} \cdot K_A}{b_{eH} \cdot c'} \quad \mu\text{m} (\mu\text{in})$$

15.3.3 Dynamic Factor, K_v , in the Subcritical Range

Cylindrical gears: ($N \leq 0.85$)

$$C_{v1} = 0.32$$

$$C_{v2} = 0.34 \quad \text{for } \varepsilon_\gamma \leq 2$$

$$C_{v2} = \frac{0.57}{\varepsilon_\gamma - 0.3} \quad \text{for } \varepsilon_\gamma > 2$$

$$C_{v3} = 0.23 \quad \text{for } \varepsilon_\gamma \leq 2$$

$$C_{v3} = \frac{0.096}{\varepsilon_\gamma - 1.56} \quad \text{for } \varepsilon_\gamma > 2$$

$$K = (C_{v1} \cdot B_p) + (C_{v2} \cdot B_f) + (C_{v3} \cdot B_k)$$

Bevel gears: ($N \leq 0.75$)

For bevel gears, $\varepsilon_{v\gamma}$ are to be substituted for ε_γ

$$K = \frac{b \cdot f_{peff} \cdot c'}{F_{mt} \cdot K_A} \cdot c_{v1,2} + c_{v3}$$

$$f_{peff} = f_{pt} - y_p \quad \text{with } y_p \approx y_a$$

$$c_{v1,2} = c_{v1} + c_{v2}$$

$$K_v = (N \cdot K) + 1$$

15.3.4 Dynamic Factor, K_v , in the Main Resonance Range

$$C_{v4} = 0.90 \quad \text{for } \varepsilon_\gamma \leq 2$$

$$C_{v4} = \frac{0.57 - 0.05 \cdot \varepsilon_\gamma}{\varepsilon_\gamma - 1.44} \quad \text{for } \varepsilon_\gamma > 2$$

Cylindrical gears: ($0.85 < N \leq 1.15$)

$$K_{v(N=1.15)} = (C_{v1} \cdot B_p) + (C_{v2} \cdot B_f) + (C_{v4} \cdot B_k) + 1$$

Bevel gears: ($0.75 < N \leq 1.25$)

For bevel gears, $\varepsilon_{v\gamma}$ are to be substituted for ε_γ

$$K_{v(N=1.25)} = \frac{b \cdot f_{peff} \cdot c'}{F_{mt} \cdot K_A} \cdot c_{v1,2} + c_{v4} + 1$$

For C_{v1} , C_{v2} , $C_{v1,2}$, and f_{peff} see 4-3-1A1/15.3.3 above.

15.3.5 Dynamic Factor, K_v , in the Supercritical Range ($N \geq 1.5$)

$$C_{v5} = 0.47$$

$$C_{v6} = 0.47 \quad \text{for } \varepsilon_\gamma \leq 2$$

$$C_{v6} = \frac{0.12}{\varepsilon_\gamma - 1.74} \quad \text{for } \varepsilon_\gamma > 2$$

$$C_{v7} = 0.75 \quad \text{for } 1.0 < \varepsilon_\gamma \leq 1.5$$

$$C_{v7} = 0.125 \cdot \sin[\pi \cdot (\varepsilon_\gamma - 2)] + 0.875 \quad \text{for } 1.5 < \varepsilon_\gamma \leq 2.5$$

$$C_{v7} = 1.0 \quad \text{for } \varepsilon_\gamma > 2.5$$

Cylindrical gears:

$$K_{v(N=1.5)} = (C_{v5} \cdot B_p) + (C_{v6} \cdot B_f) + C_{v7}$$

Bevel gears:

For bevel gears, $\varepsilon_{v\gamma}$ are to be substituted for ε_γ

$$K_{v(N=1.5)} = \frac{b \cdot f_{peff} \cdot c'}{F_{mt} \cdot K_A} \cdot c_{v5,6} + c_{v7}$$

$$c_{v5,6} = c_{v5} + c_{v6}$$

For f_{peff} see 4-3-1A1/15.3.3 above.

15.3.6 Dynamic Factor, K_v , in the Intermediate Range

Cylindrical gears:

In this range, the dynamic factor is determined by linear interpolation between K_v at $N = 1.15$ as specified in 4-3-1A1/15.3.4 and K_v at $N = 1.5$ as specified in 4-3-1A1/15.3.5.

$$K_v = K_{v(N=1.15)} + \frac{K_{v(N=1.15)} - K_{v(N=1.5)}}{0.35} \cdot (1.5 - N)$$

Bevel gears:

In this range, the dynamic factor is determined by linear interpolation between K_v at $N = 1.25$ as specified in 4-3-1A1/15.3.4 and K_v at $N = 1.5$ as specified in 4-3-1A1/15.3.5.

$$K_v = K_{v(N=1.25)} + \frac{K_{v(N=1.25)} - K_{v(N=1.5)}}{0.25} \cdot (1.5 - N)$$

17 Face Load Distribution Factors, $K_{H\beta}$ and $K_{F\beta}$

The face load distribution factors, $K_{H\beta}$ for contact stress and $K_{F\beta}$ for tooth root bending stress, account for the effects of non-uniform distribution of load across the facewidth.

$K_{H\beta}$ is defined as follows:

$$K_{H\beta} = \frac{\text{maximum load per unit facewidth}}{\text{mean load per unit facewidth}}$$

$K_{F\beta}$ is defined as follows:

$$K_{F\beta} = \frac{\text{maximum bending stress at tooth root per unit facewidth}}{\text{mean bending stress at tooth root per unit facewidth}}$$

Note: The mean bending stress at tooth root relates to the considered facewidth b_1 or b_2

$K_{F\beta}$ can be expressed as a function of the factor $K_{H\beta}$

The factors $K_{H\beta}$ and $K_{F\beta}$ mainly depend on:

- Gear tooth manufacturing accuracy
- Errors in mounting due to bore errors
- Bearing clearances
- Wheel and pinion shaft alignment errors
- Elastic deflections of gear elements, shafts, bearings, housing and foundations which support the gear elements
- Thermal expansion and distortion due to operating temperature
- Compensating design elements (tooth crowning, end relief, etc.)

These factors can be obtained from 4-3-1A1/17.3 and 4-3-1A1/17.5, using the factors in 4-3-1A1/17.1.

17.1 Factors Used for the Determination of $K_{H\beta}$

17.1.1 Helix Deviation F_β

The helix deviation, F_β is to be determined by the designer or by the following equations and tables:

SI and MKS units, μm	US units, $\mu\text{in.}$
$F_\beta = 0.1\sqrt{d_{geom}} + 0.63\sqrt{b_{geom}} + 4.2$ for ISO Grade of accuracy $Q = 5$	$F_\beta = 19.8\sqrt{d_{geom}} + 125.0\sqrt{b_{geom}} + 165.4$ for ISO Grade of accuracy $Q = 5$
For other accuracy grades, multiply F_β by the following formula: $2^{0.5(Q-5)}$ where $0 \leq Q \leq 12$	

SI and MKS units		US units	
Reference diameter d mm	Corresponding geometric mean diameter d_{geom} mm	Reference diameter d in	Corresponding geometric mean diameter d_{geom} in.
$5 \leq d \leq 20$	10.00	$0.2 \leq d \leq 0.79$	0.3937
$20 < d \leq 50$	31.62	$0.79 \leq d \leq 2.0$	1.245
$50 < d \leq 125$	79.06	$2.0 \leq d \leq 4.92$	3.112
$125 < d \leq 280$	187.1	$4.92 \leq d \leq 11.0$	7.365
$280 < d \leq 560$	396.0	$11.0 \leq d \leq 22.0$	15.59
$560 < d \leq 1000$	748.3	$22.0 \leq d \leq 39.37$	29.46
$1000 < d \leq 1600$	1265	$39.37 \leq d \leq 62.99$	49.80
$1600 < d \leq 2500$	2000	$62.99 \leq d \leq 98.43$	78.74
$2500 < d \leq 4000$	3162	$98.43 \leq d \leq 157.5$	124.5
$4000 < d \leq 6000$	4899	$157.5 \leq d \leq 236.2$	192.9
$6000 < d \leq 8000$	6928	$236.2 \leq d \leq 315.0$	272.8
$8000 < d \leq 10000$	8944	$315.0 \leq d \leq 393.70$	352.1

SI and MKS units		US units	
Facewidth b mm	Corresponding geometric mean facewidth b_{geom} mm	Facewidth b in	Corresponding geometric mean facewidth b_{geom} in.
$4 < b \leq 10$	6.325	$0.16 < b \leq 0.39$	0.2490
$10 < b \leq 20$	14.14	$0.39 < b \leq 0.79$	0.5568
$20 < b \leq 40$	28.28	$0.79 < b \leq 1.6$	1.114
$40 < b \leq 80$	56.57	$1.6 < b \leq 3.15$	2.227
$80 < b \leq 160$	113.1	$3.15 < b \leq 6.30$	4.454
$160 < b \leq 250$	200.0	$6.30 < b \leq 9.84$	7.874
$250 < b \leq 400$	316.2	$9.84 < b \leq 15.7$	12.45
$400 < b \leq 650$	509.9	$15.7 < b \leq 25.6$	20.07
$650 < b \leq 1000$	806.2	$25.6 < b \leq 39.37$	31.74

Rounding Rules			
For resulting F_{β}	$F_{\beta} < 5 \mu\text{m}$	$5 \mu\text{m} \leq F_{\beta} \leq 10 \mu\text{m}$	$F_{\beta} > 10 \mu\text{m}$ (μin)
		Round to the nearest 0.1 μm value or integer number	Round to the nearest 0.5 μm value or integer number

17.1.2 Mesh Alignment f_{ma} [μm (μin)]

Generally: $f_{ma} = 1.0 \cdot F_{\beta}$

For gear pairs with well-designed end relief: $f_{ma} = 0.7 \cdot F_{\beta}$.

For gear pairs with provision for adjustment (lapping or running-in under light load, adjustment bearings or appropriate helix modification) and gear pairs suitably crowned: $f_{ma} = 0.5 \cdot F_{\beta}$

For helix deviation due to manufacturing inaccuracies: $f_{ma} = 0.5 \cdot F_{\beta}$

17.1.3 Initial Equivalent Misalignment $F_{\beta\chi}$ [μm (μin)]

$F_{\beta\chi}$ is the absolute value of the sum of manufacturing deviations and pinion and shaft deflections, measured in the plane of action.

$$F_{\beta\chi} = 1.33 \cdot f_{sh} + f_{ma}$$

$$f_{sh} = f_{sh0} \cdot \frac{F_t \cdot K_A \cdot K_{\gamma} \cdot K_v}{b}$$

$$f_{sh0min} = 0.005 \quad \mu\text{m-mm/N} \quad [\text{SI units}]$$

$$f_{sh0min} = 0.049 \quad \mu\text{m-mm/kgf} \quad [\text{MKS units}]$$

$$f_{sh0min} = 0.03445 \quad \mu\text{in-in/lbf} \quad [\text{US units}]$$

	SI units [$\mu\text{m-mm/N}$]	MKS units [$\mu\text{m-mm/kgf}$]	US units [$\mu\text{in-in/lbf}$]
For spur and helical gears without crowning or end relief	$f_{sh0} = 0.023 \cdot \gamma$	$f_{sh0} = 0.22555 \cdot \gamma$	$f_{sh0} = 0.15858 \cdot \gamma$
For spur and helical gears without crowning but with end relief	$f_{sh0} = 0.016 \cdot \gamma$	$f_{sh0} = 0.15691 \cdot \gamma$	$f_{sh0} = 0.11032 \cdot \gamma$
For spur and helical gears with crowning	$f_{sh0} = 0.012 \cdot \gamma$	$f_{sh0} = 0.11768 \cdot \gamma$	$f_{sh0} = 0.08274 \cdot \gamma$
For spur and helical gears with crowning and end relief	$f_{sh0} = 0.010 \cdot \gamma$	$f_{sh0} = 0.09807 \cdot \gamma$	$f_{sh0} = 0.06895 \cdot \gamma$

$$\gamma = \left[1 + K' \cdot \frac{\ell \cdot s}{d_1^2} \cdot \left(\frac{d_1}{d_{sh}} \right)^4 - 0.3 \right] + 0.3 \cdot \left(\frac{b}{d_1} \right)^2 \quad \text{for spur and single helical gears}$$

$$\gamma = 2 \cdot \left[1.5 + K' \cdot \frac{\ell \cdot s}{d_1^2} \cdot \left(\frac{d_1}{d_{sh}} \right)^4 - 0.3 \right] + 0.3 \cdot \left(\frac{b_B}{d_1} \right)^2 \quad \text{for double helical gears}$$

where $b_B = b/2$ is the width of one helix.

The constant K' makes allowances for the position of the pinion in relation to the torqued end. It can be taken from 4-3-1A1/Table 6.

17.1.4 Determination of y_β and χ_β for Structural Steels, Through Hardened Steels and Nodular Cast Iron (Pearlite, Bainite)

SI units	MKS units	US units
$y_\beta = \frac{320}{\sigma_{H \text{ lim}}} \cdot F_{\beta\chi} \quad \mu\text{m}$	$y_\beta = \frac{32.63}{\sigma_{H \text{ lim}}} \cdot F_{\beta\chi} \quad \mu\text{m}$	$y_\beta = \frac{4.662 \cdot 10^4}{\sigma_{H \text{ lim}}} \cdot F_{\beta\chi} \quad \mu\text{in}$
$\chi_\beta = 1 - \frac{320}{\sigma_{H \text{ lim}}}$ with $y_\beta \leq F_{\beta\chi}$; $\chi_\beta \geq 0$	$\chi_\beta = 1 - \frac{32.63}{\sigma_{H \text{ lim}}}$ with $y_\beta \leq F_{\beta\chi}$; $\chi_\beta \geq 0$	$\chi_\beta = 1 - \frac{4.662 \cdot 10^4}{\sigma_{H \text{ lim}}}$ with $y_\beta \leq F_{\beta\chi}$; $\chi_\beta \geq 0$
For $v \leq 5$ m/s no restriction	For $v \leq 5$ m/s no restriction	For $v \leq 984$ ft/min no restriction
For $5 \text{ m/s} < v \leq 10 \text{ m/s}$: $y_{\beta \text{ max}} = \frac{25600}{\sigma_{H \text{ lim}}}$ corresponding to $F_{\beta\chi} = 80 \mu\text{m}$	For $5 \text{ m/s} < v \leq 10 \text{ m/s}$: $y_{\beta \text{ max}} = \frac{2.61 \cdot 10^3}{\sigma_{H \text{ lim}}}$ corresponding to $F_{\beta\chi} = 80 \mu\text{m}$	For $984 \text{ ft/min} < v \leq 1968 \text{ ft/min}$: $y_{\beta \text{ max}} = \frac{14.682 \cdot 10^7}{\sigma_{H \text{ lim}}}$ corresponding to $F_{\beta\chi} = 3150 \mu\text{in}$
For $v > 10$ m/s: $y_{\beta \text{ max}} = \frac{12800}{\sigma_{H \text{ lim}}}$ corresponding to $F_{\beta\chi} = 40 \mu\text{m}$	For $v > 10$ m/s: $y_{\beta \text{ max}} = \frac{1.305 \cdot 10^3}{\sigma_{H \text{ lim}}}$ corresponding to $F_{\beta\chi} = 40 \mu\text{m}$	For $v > 1968$ ft/min: $y_{\beta \text{ max}} = \frac{7.341 \cdot 10^7}{\sigma_{H \text{ lim}}}$ corresponding to $F_{\beta\chi} = 1575 \mu\text{in}$

For $\sigma_{H \text{ lim}}$, see 4-3-1A1/Table 3.

17.1.5 Determination of y_β and χ_β for Gray Cast Iron and Nodular Cast Iron (Ferritic):

SI & MKS units, μm	US units, μin
$Y_\beta = 0.55 \cdot F_{\beta\chi}$	$Y_\beta = 0.55 \cdot F_{\beta\chi}$
$\chi_\beta = 0.45$	$\chi_\beta = 0.45$
For $v \leq 5$ m/s, no restriction	For $v \leq 984$ ft/min, no restriction
For $5 \text{ m/s} < v \leq 10 \text{ m/s}$: $y_{\beta\max} = 45$ corresponding to $F_{\beta\chi} = 80 \mu m$	For $984 \text{ ft/min} < v \leq 1968 \text{ ft/min}$: $y_{\beta\max} = 1771$ corresponding to $F_{\beta\chi} = 3150 \mu in$
For $v > 10$ m/s: $y_{\beta\max} = 22$ corresponding to $F_{\beta\chi} = 40 \mu m$	For $v > 1968$ ft/min: $y_{\beta\max} = 866$ corresponding to $F_{\beta\chi} = 1575 \mu in$

17.1.6 Determination of y_β and χ_β for Case Hardened, Nitrided or Nitrocarburized Steels:

SI & MKS units	US units
$Y_\beta = 0.15 \cdot F_{\beta\chi} \mu m$	$Y_\beta = 0.15 \cdot F_{\beta\chi} \mu in$
$\chi_\beta = 0.85$	$\chi_\beta = 0.85$
For all velocities but with the restriction: $y_{\beta\max} = 6$ corresponding to $F_{\beta\chi} = 40 \mu m$	For all velocities but with the restriction: $y_{\beta\max} = 236$ corresponding to $F_{\beta\chi} = 1575 \mu in$

When the material of the pinion differs from that of the wheel, $y_{\beta 1}$ and $\chi_{\beta 1}$ for pinion, and $y_{\beta 2}$ and $\chi_{\beta 2}$ for wheel are to be determined separately. The mean of either value:

$$y_\beta = 0.5 \cdot (y_{\beta 1} + y_{\beta 2})$$

$$\chi_\beta = 0.5 \cdot (\chi_{\beta 1} + \chi_{\beta 2})$$

is to be used for the calculation.

17.3 Face Load Distribution Factor for Contact Stress $K_{H\beta}$

17.3.1 $K_{H\beta}$ for Helical and Spur Gears

$$K_{H\beta} = 1 + \frac{b \cdot F_{\beta y} \cdot C\gamma}{2 \cdot F_t \cdot K_A \cdot K_\gamma \cdot K_v} < 2, \text{ for } \frac{b \cdot F_{\beta y} \cdot C\gamma}{2 \cdot F_t \cdot K_A \cdot K_\gamma \cdot K_v} < 1$$

$$K_{H\beta} = \sqrt{\frac{2 \cdot b \cdot F_{\beta y} \cdot C\gamma}{F_t \cdot K_A \cdot K_\gamma \cdot K_v}} \geq 2 \text{ for } \frac{b \cdot F_{\beta y} \cdot C\gamma}{2 \cdot F_t \cdot K_A \cdot K_\gamma \cdot K_v} \geq 1$$

where:

$$F_{\beta y} = F_{\beta x} - y_\beta \quad \text{or} \quad F_{\beta y} = F_{\beta x} \cdot \chi_\beta$$

Calculated values of $K_{H\beta} \geq 2$ are to be reduced by improvement accuracy and helix deviation.

17.3.2 $K_{H\beta}$ for Bevel Gears

$$K_{H\beta} = 1.5 \cdot \frac{0.85}{B_b} \cdot K_{H\beta be}$$

The bearing factor, $K_{H\beta be}$, representing the influence of the bearing arrangement on the faceload distribution, is given in the following table:

<i>Mounting conditions of pinion and wheel</i>		
Both members straddle mounted	One member straddle mounted	Neither member straddle mounted
1.10	1.25	1.50
Based on optimum tooth contact pattern under maximum operating load as evidenced by results of a deflection test on the gears in their mountings.		

17.5 Face Load Distribution Factor for Tooth Root Bending Stress $K_{F\beta}$

17.5.1 In Case the Hardest Contact is at the End of the Face-width $K_{F\beta}$ is Given by the Following Equations

$$K_{F\beta} = (K_{H\beta})^N$$

$$N = \frac{(b/h)^2}{1 + (b/h) + (b/h)^2} = \frac{1}{1 + (h/b) + (h/b)^2}$$

(b/h) = (facewidth/tooth depth), the lesser of b_1/h_1 or b_2/h_2 . For double helical gears, the facewidth of only one helix is to be used, i.e., $b_B = b/2$ is to be substituted for b in the equation for N .

17.5.2 In Case of Gears Where the Ends of the Facewidth are Lightly Loaded or Unloaded (End Relief or Crowning)

$$K_{F\beta} = K_{H\beta}$$

17.5.3 Bevel Gears

$$K_{F\beta} = \frac{K_{H\beta}}{K_{FO}}$$

$$K_{FO} = 0.211 \cdot \left(\frac{r_{eo}}{R_m} \right)^q + 0.789 \quad \text{for spiral bevel gears.}$$

$$q = \frac{0.279}{\log(\sin \beta_m)}$$

where

$$K_{FO} = 1 \quad \text{for straight or zero bevel gears.}$$

$$r_{eo} = \text{cutter radius, mm (in.)}$$

$$R_m = \text{mean cone distance, mm (in.)}$$

Limitations of K_{FO} :

$$\text{If } K_{FO} < \text{unity, use } K_{FO} = \text{unity}$$

$$\text{If } K_{FO} > 1.15, \text{ use } K_{FO} = 1.15$$

19 Transverse Load Distribution Factors, $K_{H\alpha}$ and $K_{F\alpha}$

The transverse load distribution factors, $K_{H\alpha}$ for contact stress and $K_{F\alpha}$ for tooth root bending stress, account for the effects of pitch and profile errors on the transversal load distribution between two or more pairs of teeth in mesh.

The factors $K_{H\alpha}$ and $K_{F\alpha}$ mainly depend on:

- Total mesh stiffness
- Total tangential load F_t , K_A , K_γ , K_v , $K_{H\beta}$
- Base pitch error
- Tip relief
- Running-in allowances

The load distribution factors, $K_{H\alpha}$ and $K_{F\alpha}$ are to be advised by the manufacturer as supported by his measurements, analysis or experience data or are to be determined as follows.

19.1 Determination of $K_{H\alpha}$ for Contact Stress $K_{F\alpha}$ for Tooth Root Bending Stress

$$K_{H\alpha} = K_{F\alpha} = 0.9 + 0.4 \cdot \sqrt{\frac{2 \cdot (\varepsilon_\gamma - 1)}{\varepsilon_\gamma} \cdot \frac{C_\gamma \cdot (f_{pbe} - y_a) \cdot b}{F_{tH}}} \quad \text{for } \varepsilon_\gamma > 2$$

$$K_{H\alpha} = K_{F\alpha} = \frac{\varepsilon_\gamma}{2} \cdot \left[0.9 + 0.4 \cdot \frac{C_\gamma \cdot (f_{pbe} - y_a) \cdot b}{F_{tH}} \right] \quad \text{for } \varepsilon_\gamma \leq 2$$

Cylindrical gears:

$$F_{tH} = F_t \cdot K_A \cdot K_\gamma \cdot K_v \cdot K_{H\beta} \quad \text{N (kgf, lbf)}$$

$$f_{pbe} = f_{pb} \cdot \cos \alpha_t$$

Bevel gears:

$$F_{mH} = F_{mt} \cdot K_A \cdot K_v \cdot K_{H\beta} \quad \text{N (kgf, lbf)}$$

For bevel gears, f_{pt} , $\varepsilon_{v\gamma}$, F_{mH} , F_{mt} and α_{vt} (equivalent) are to be substituted for f_{pbe} , ε_γ , F_{tH} , F_t and α_t in the above formulas.

19.3 Limitations of $K_{H\alpha}$ and $K_{F\alpha}$

19.3.1 $K_{H\alpha}$

When $K_{H\alpha} < 1$, use 1.0 for $K_{H\alpha}$

Cylindrical gears:

When $K_{H\alpha} > \frac{\varepsilon_\gamma}{\varepsilon_\alpha \cdot Z_\varepsilon^2}$, use $\frac{\varepsilon_\gamma}{\varepsilon_\alpha \cdot Z_\varepsilon^2}$ for $K_{H\alpha}$:

$$Z_\varepsilon = \sqrt{\frac{4 - \varepsilon_\alpha}{3} \cdot (1 - \varepsilon_\beta) + \frac{\varepsilon_\beta}{\varepsilon_\alpha}}, \quad \text{contact ratio factor (pitting) for helical gears for } \varepsilon_\beta < 1$$

$$Z_\varepsilon = \sqrt{\frac{1}{\varepsilon_\alpha}}, \quad \text{contact ratio factor (pitting) for helical gears for } \varepsilon_\beta \geq 1$$

$$Z_\varepsilon = \sqrt{\frac{4 - \varepsilon_\alpha}{3}}, \quad \text{contact ratio factor (pitting) for spur gears}$$

Bevel gears:

$$\text{When } K_{H\alpha} > \frac{\varepsilon_{v\gamma}}{\varepsilon_{v\alpha} \cdot Z_{LS}^2}, \text{ use } \frac{\varepsilon_{v\gamma}}{\varepsilon_{v\alpha} \cdot Z_{LS}^2} \text{ for } K_{H\alpha}$$

For the calculation of Z_{LS} , see 4-3-1A1/21.13.

19.3.2 $K_{F\alpha}$

When $K_{F\alpha} < 1$, use 1.0 for $K_{F\alpha}$.

$$\text{When } K_{F\alpha} > \frac{\varepsilon_{\gamma}}{\varepsilon_{\alpha} \cdot Y_{\varepsilon}}, \text{ use } \frac{\varepsilon_{\gamma}}{\varepsilon_{\alpha} \cdot Y_{\varepsilon}} \text{ for } K_{F\alpha};$$

$$Y_{\varepsilon} = 0.25 + \frac{0.75}{\varepsilon_{\alpha}}, \quad \text{contact ratio factor for } \varepsilon_{\beta} = 0$$

$$Y_{\varepsilon} = 0.25 + \frac{0.75}{\varepsilon_{\alpha}} - \left(\frac{0.75}{\varepsilon_{\alpha}} - 0.375 \right) \cdot \varepsilon_{\beta}, \quad \text{contact ratio factor for } 0 < \varepsilon_{\beta} < 1$$

$$Y_{\varepsilon} = 0.625, \quad \text{contact ratio factor for } \varepsilon_{\beta} \geq 1$$

or:

$$Y_{\varepsilon} = 0.25 + \frac{0.75 \cdot \cos^2 \beta_b}{\varepsilon_{\alpha}} \quad \text{for cylindrical gears only}$$

For bevel gears, $\varepsilon_{v\gamma}$, $\varepsilon_{v\beta}$ and $\varepsilon_{v\alpha}$ (equivalent) are to be substituted for ε_{γ} , ε_{β} and ε_{α} in the above formulas.

21 Surface Durability

The criterion for surface durability is based on the Hertzian pressure on the operating pitch point or at the inner point of single pair contact. The contact stress σ_H is not to exceed the permissible contact stress σ_{HP} .

21.1 Contact Stress

$$\sigma_{H1} = \sigma_{HO1} \cdot \sqrt{K_A \cdot K_{\gamma} \cdot K_v \cdot K_{H\alpha} \cdot K_{H\beta}} \leq \sigma_{HP1}$$

$$\sigma_{H2} = \sigma_{HO2} \cdot \sqrt{K_A \cdot K_{\gamma} \cdot K_v \cdot K_{H\alpha} \cdot K_{H\beta}} \leq \sigma_{HP2}$$

Cylindrical gears:

$\sigma_{HO1,2}$ = basic value of contact stress for pinion and wheel

$$\sigma_{HO1} = Z_B \cdot Z_H \cdot Z_E \cdot Z_{\varepsilon} \cdot Z_{\beta} \cdot \sqrt{\frac{F_t}{d_1 \cdot b} \cdot \frac{u+1}{u}} \quad \text{for pinion}$$

$$\sigma_{HO2} = Z_D \cdot Z_H \cdot Z_E \cdot Z_{\varepsilon} \cdot Z_{\beta} \cdot \sqrt{\frac{F_t}{d_1 \cdot b} \cdot \frac{u+1}{u}} \quad \text{for wheel}$$

where

Z_B = single pair mesh factor for pinion, see 4-3-1A1/21.5 below

Z_D = single pair mesh factor for wheel, see 4-3-1A1/21.5 below

Z_H = zone factor, see 4-3-1A1/21.7 below

- Z_E = elasticity factor, see 4-3-1A1/21.9 below
 Z_ε = contact ratio factor (pitting), see 4-3-1A1/21.11 below
 Z_β = helix angle factor, see 4-3-1A1/21.17 below
 F_t = nominal transverse tangential load, see 4-3-1A1/9 of this Appendix.

Gear ratio u for external gears is positive, for internal gears, u is negative.

Regarding factors K_A , K_γ , K_v , $K_{H\alpha}$ and $K_{H\beta}$, see 4-3-1A1/11, 4-3-1A1/13, 4-3-1A1/15, 4-3-1A1/19 and 4-3-1A1/17 of this Appendix.

Bevel gears:

σ_{HO1} = basic value of contact stress for pinion

$$\sigma_{HO1} = Z_{M-B} \cdot Z_H \cdot Z_E \cdot Z_{LS} \cdot Z_\beta \cdot Z_K \cdot \sqrt{\frac{F_{mt}}{d_{v1} \cdot \ell_{bm}} \cdot \frac{u_v + 1}{u_v}}$$

For the shaft angle $\Sigma = \delta_1 + \delta_2 = 90^\circ$ the following applies:

$$\sigma_{HO1} = Z_{M-B} \cdot Z_H \cdot Z_E \cdot Z_{LS} \cdot Z_\beta \cdot Z_K \cdot \sqrt{\frac{F_{mt}}{d_{m1} \cdot \ell_{bm}} \cdot \frac{\sqrt{u^2 + 1}}{u}}$$

where

- Z_{M-B} = mid-zone factor, see 4-3-1A1/21.5 below
 Z_H = zone factor, see 4-3-1A1/21.7 below
 Z_E = elasticity factor, see 4-3-1A1/21.9 below
 Z_{LS} = load sharing factor, see 4-3-1A1/21.13 below
 Z_β = helix angle factor, see 4-3-1A1/21.17 below
 Z_K = bevel gear factor (flank), see 4-3-1A1/21.15 below
 F_{mt} = nominal transverse tangential load, see 4-3-1A1/9 of this appendix.
 d_{m1} = mean pitch diameter of pinion of bevel gear
 d_{v1} = reference diameter of pinion of virtual (equivalent) cylindrical gear
 ℓ_{bm} = length of middle line of contact
 u_v = gear ratio of virtual (equivalent) cylindrical gear
 u = gear ratio of bevel gear

21.3 Permissible Contact Stress

The permissible contact stress, σ_{HP} , is to be evaluated separately for pinion and wheel.

$$\sigma_{HP} = \frac{\sigma_{Hlim}}{S_H} \cdot Z_N \cdot Z_L \cdot Z_V \cdot Z_R \cdot Z_W \cdot Z_X \quad \text{N/mm}^2 \text{ (kgf/mm}^2, \text{ psi)}$$

where:

- σ_{Hlim} = endurance limit for contact stress, see 4-3-1A1/21.19 below
 Z_N = life factor for contact stress, see 4-3-1A1/21.21 below
 Z_L = lubrication factor, see 4-3-1A1/21.23 below

- Z_V = speed factor, see 4-3-1A1/21.23 below
 Z_R = roughness factor, see 4-3-1A1/21.23 below
 Z_W = hardness ratio factor, see 4-3-1A1/21.25 below
 Z_X = size factor for contact stress, see 4-3-1A1/21.27 below
 S_H = safety factor for contact stress, see 4-3-1A1/21.29 below

For shrink-fitted wheel rims, σ_{HP} is to be at least K_S times the mean contact stress σ_H , where

K_S = safety factor available for induced contact stresses, and is to be calculated as follows:

$$1 + \frac{\delta_{\max} \cdot 2.2 \times 10^5}{Y} \cdot \frac{d_{ri}}{d_{w2}^2} \cdot \frac{0.25m_n}{\rho_{F2}} \quad [\text{SI units}]$$

$$1 + \frac{\delta_{\max} \cdot 2.243 \times 10^4}{Y} \cdot \frac{d_{ri}}{d_{w2}^2} \cdot \frac{0.25m_n}{\rho_{F2}} \quad [\text{MKS units}]$$

$$K_S = 1 + \frac{\delta_{\max} \cdot 3.194 \times 10^7}{Y} \cdot \frac{d_{ri}}{d_{w2}^2} \cdot \frac{0.25m_n}{\rho_{F2}} \quad [\text{US units}]$$

where

- δ_{\max} = maximum available interference fit or maximum pull-up length; mm (in.)
 d_{ri} = inner diameter of wheel rim; mm (in.)
 d_{w2} = working pitch diameter of wheel; mm (in.)
 m_n = normal module; mm (in.)
 Y = yield strength of wheel rim material is to be as follows:
- minimum specified yield strength for through hardened (quenched and tempered) steels
 - 500 N/mm² (51 kgf/mm², 72520 psi) for case hardened, nitrided steels

21.5 Single Pair Mesh Factors, Z_B , Z_D and Mid-zone Factor Z_{M-B}

The single pair mesh factors, Z_B for pinion and Z_D for wheel, account for the influence on contact stresses of the tooth flank curvature at the inner point of single pair contact in relation to Z_H .

The factors transform the contact stresses determined at the pitch point to contact stresses considering the flank curvature at the inner point of single pair contact.

21.5.1 For Cylindrical and Bevel Gears when $\varepsilon_\beta = 0$

21.5.1(a) Cylindrical Gears

$Z_B = M_1$ or 1, whichever is the larger value

$Z_D = M_2$ or 1, whichever is the larger value

$$M_1 = \frac{\tan \alpha_{wt}}{\sqrt{\left[\sqrt{\left(\frac{d_{a1}}{d_{b1}} \right)^2 - 1} - (2\pi/z_1) \right] \cdot \left[\sqrt{\left(\frac{d_{a2}}{d_{b2}} \right)^2 - 1} - (\varepsilon_\alpha - 1) \cdot (2\pi/z_2) \right]}}$$

$$M_2 = \frac{\tan \alpha_{wt}}{\sqrt{\left[\sqrt{\left(\frac{d_{a2}}{d_{b2}} \right)^2 - 1} - (2\pi/z_2) \right] \cdot \left[\sqrt{\left(\frac{d_{a1}}{d_{b1}} \right)^2 - 1} - (\varepsilon_\alpha - 1) \cdot (2\pi/z_1) \right]}}$$

21.5.1(b) *Bevel Gears*

$$Z_{M-B} = M$$

$$M = \frac{\tan \alpha_{vt}}{\sqrt{\left[\sqrt{(d_{va1}/d_{vb1})^2 - 1} - (2\pi/z_{v1}) \right] \cdot \left[\sqrt{(d_{va2}/d_{vb2})^2 - 1} - (\varepsilon_{v\alpha} - 1) \cdot (2\pi/z_{v2}) \right]}}$$

21.5.2 For Cylindrical and Bevel Gears when $\varepsilon_\beta \geq 1$

21.5.2(a) *Cylindrical Gears*

$$Z_B = Z_D = 1 \text{ for cylindrical gears}$$

21.5.2(b) *Bevel Gears*

$$Z_{M-B} = M$$

$$M = \frac{\tan \alpha_{vt}}{\sqrt{\left[\sqrt{(d_{va1}/d_{vb1})^2 - 1} - \varepsilon_{v\alpha} \cdot (\pi/z_{v1}) \right] \cdot \left[\sqrt{(d_{va2}/d_{vb2})^2 - 1} - \varepsilon_{v\alpha} \cdot (\pi/z_{v2}) \right]}}$$

21.5.3 For Cylindrical and Bevel Gears when $0 < \varepsilon_\beta < 1$

21.5.3(a) *Cylindrical Gears*

The values of Z_B , Z_A are determined by linear interpolation between Z_B , Z_A for spur gears and Z_B , Z_A for helical gears having $\varepsilon_\beta \geq 1$

Thus:

$$Z_B = M_1 - \varepsilon_\beta (M_1 - 1) \text{ and } Z_B \geq 1$$

$$Z_D = M_2 - \varepsilon_\beta (M_2 - 1) \text{ and } Z_D \geq 1$$

21.5.3(b) *Bevel Gears*

$$Z_{M-B} = M$$

$$M = \frac{\tan \alpha_{vt}}{\sqrt{\left[\sqrt{(d_{va1}/d_{vb1})^2 - 1} - (2 + (\varepsilon_{v\alpha} - 2) \cdot \varepsilon_{v\beta}) \cdot (\pi/z_{v1}) \right] \cdot \left[\sqrt{(d_{va2}/d_{vb2})^2 - 1} - (2(\varepsilon_{v\alpha} - 1) + (2 - \varepsilon_{v\alpha}) \cdot \varepsilon_{v\beta}) \cdot (\pi/z_{v2}) \right]}}$$

21.7 Zone Factor, Z_H

Cylindrical gears:

The zone factor, Z_H , accounts for the influence on the Hertzian pressure of tooth flank curvature at pitch point and relates the tangential force at the reference cylinder to the normal force at the pitch cylinder.

$$Z_H = \sqrt{\frac{2 \cdot \cos \beta_b \cdot \cos \alpha_{wt}}{\cos^2 \alpha_t \cdot \sin \alpha_{wt}}}$$

Bevel gears:

$$Z_H = 2 \cdot \sqrt{\frac{\cos \beta_{vb}}{\sin(2 \cdot \alpha_{vt})}}$$

21.9 Elasticity Factor, Z_E

The elasticity factor, Z_E , accounts for the influence of the material properties E (modulus of elasticity) and ν (Poisson's ratio) on the Hertzian pressure.

$$Z_E = \sqrt{\frac{1}{\pi \cdot \left[\frac{1-\nu_1^2}{E_1} + \frac{1-\nu_2^2}{E_2} \right]}}$$

With Poisson's ratio of 0.3 and same E and ν for pinion and wheel, Z_E may be obtained from the following:

$$Z_E = \sqrt{0.175 \cdot E}$$

with E = Young's modulus of elasticity.

The elasticity factor, Z_E , for steel gears [$E_{st} = 206000 \text{ N/mm}^2$ ($2.101 \times 10^4 \text{ kgf/mm}^2$, $2.988 \times 10^7 \text{ psi}$) is:

Elasticity factor Z_E		
SI units	MKS units	US units
189.8 $\text{N}^{1/2}/\text{mm}$	60.61 $\text{kgf}^{1/2}/\text{mm}$	2.286×10^3 $\text{lbf}^{1/2}/\text{in}$

For other material combinations, refer to 4-3-1A1/Table 1.

21.11 Contact Ratio Factor (Pitting), Z_ϵ

The contact ratio factor, Z_ϵ , accounts for the influence of the transverse contact ratio and the overlap ratio on the specific surface load of gears.

Spur gears:

$$Z_\epsilon = \sqrt{\frac{4 - \epsilon_\alpha}{3}}$$

Helical gears:

$$\text{For } \epsilon_\beta < 1: Z_\epsilon = \sqrt{\frac{4 - \epsilon_\alpha}{3} \cdot (1 - \epsilon_\beta) + \frac{\epsilon_\beta}{\epsilon_\alpha}}$$

$$\text{For } \epsilon_\beta \geq 1: Z_\epsilon = \sqrt{\frac{1}{\epsilon_\alpha}}$$

21.13 Bevel Gear Load Sharing Factor, Z_{LS}

The load sharing factor, Z_{LS} , accounts for the load sharing between two or more pair of teeth in contact.

$$\text{For } \epsilon_{v\gamma} \leq 2: Z_{LS} = 1$$

$$\text{For } \epsilon_{v\gamma} > 2 \text{ and } \epsilon_{v\beta} > 1: Z_{LS} = \left[1 + 2 \cdot \left\{ 1 - (2/\epsilon_{v\gamma})^{1.5} \right\} \cdot \sqrt{1 - (4/\epsilon_{v\gamma}^2)} \right]^{-0.5}$$

For other cases: The calculation of Z_{LS} can be based upon the method used in ISO 10300-2, Annex A, Load Sharing Factor, Z_{LS} .

21.15 Bevel Gear Factor (Flank), Z_K

The bevel gear factor (flank), Z_K , accounts the difference between bevel and cylindrical loading and adjusts the contact stresses so that the same permissible stresses may apply.

$$Z_K = 0.8$$

21.17 Helix Angle Factor, Z_β

The helix angle factor, Z_β , accounts for the influence of helix angle on surface durability, allowing for such variables as the distribution of load along the lines of contact. Z_β is dependent only on the helix angle.

$$\text{Cylindrical gears: } Z_\beta = \frac{1}{\sqrt{\cos \beta}}$$

$$\text{Bevel gears: } Z_\beta = \sqrt{\cos \beta_m}$$

21.19 Allowable Stress Number (Contact), σ_{Hlim}

For a given material, σ_{Hlim} is the limit of repeated contact stress that can be sustained without progressive pitting. For most materials, their load cycles may be taken at 50×10^6 , unless otherwise specified.

For this purpose, pitting is defined as follows:

- Not surface hardened gears: pitted area > 2% of total active flank area.
- Surface hardened gears: pitted area > 0.5% of total active flank area, or > 4% of one particular tooth flank area.

The endurance limit depends mainly on:

- Material composition, cleanliness and defects
- Mechanical properties
- Residual stresses
- Hardening process, depth of hardened zone, hardness gradient
- Material structure (forged, rolled bar, cast)

The σ_{Hlim} values correspond to a failure probability of 1% or less. The values of σ_{Hlim} are to be determined from 4-3-1A1/Table 3 or to be advised by the manufacturer together with technical justification for the proposed values.

21.21 Life Factor, Z_N

The life factor, Z_N , accounts for the higher permissible contact stress, including static stress in case a limited life (number of load cycles) is specified.

The factor depends mainly on:

- Material and hardening
- Number of cycles
- Influence factors (Z_R, Z_V, Z_L, Z_W, Z_X)

The life factor, Z_N , can be determined from 4-3-1A1/Table 4.

21.23 Influence Factors on Lubrication Film, Z_L, Z_V and Z_R

The lubricant factor, Z_L , accounts for the influence of the type of lubricant and its viscosity.

The speed factor, Z_V , accounts for the influence of the pitch line velocity.

The roughness factor, Z_R , accounts for the influence of the surface roughness on the surface endurance capacity.

The factors mainly depend on:

- Viscosity of lubricant in the contact zone
- The sum of the instantaneous velocities of the tooth surfaces
- Load
- Relative radius of curvature at the pitch point
- Surface roughness of teeth flanks
- Hardness of pinion and gear

Where gear pairs are of different hardness, the factors may be based on the less hardened material.

21.23.1 Lubricant Factor, Z_L

$$Z_L = C_{ZL} + \frac{4 \cdot (1.0 - C_{ZL})}{[1.2 + (134/\nu_{40})]^2} \quad [\text{SI and MKS units}]$$

$$Z_L = C_{ZL} + \frac{4 \cdot (1.0 - C_{ZL})}{[1.2 + (0.208/\nu_{40})]^2} \quad [\text{US units}]$$

or

$$Z_L = C_{ZL} + \frac{4 \cdot (1.0 - C_{ZL})}{[1.2 + (80/\nu_{50})]^2} \quad [\text{SI and MKS units}]$$

$$Z_L = C_{ZL} + \frac{4 \cdot (1.0 - C_{ZL})}{[1.2 + (0.127/\nu_{50})]^2} \quad [\text{US units}]$$

where σ_{Hlim} is the allowable stress number (contact) of the softer material.

a) with σ_{Hlim} in the range of:

$$850 \text{ N/mm}^2 (87 \text{ kgf/mm}^2, 1.23 \times 10^5 \text{ psi}) < \sigma_{Hlim} < 1200 \text{ N/mm}^2 (122 \text{ kgf/mm}^2, 1.74 \times 10^5 \text{ psi})$$

$$C_{ZL} = \left(0.08 \cdot \frac{\sigma_{Hlim} - 850}{350} \right) + 0.83 \quad [\text{SI units}]$$

$$C_{ZL} = \left(0.08 \cdot \frac{\sigma_{Hlim} - 87}{35.7} \right) + 0.83 \quad [\text{MKS units}]$$

$$C_{ZL} = \left(0.08 \cdot \frac{\sigma_{Hlim} - 1.23 \cdot 10^5}{5.076 \times 10^4} \right) + 0.83 \quad [\text{US units}]$$

b) with σ_{Hlim} in the range of $\sigma_{Hlim} < 850 \text{ N/mm}^2 (87 \text{ kgf/mm}^2, 1.23 \times 10^5 \text{ psi})$, $C_{ZL} = 0.83$;

c) with σ_{Hlim} in the range of $\sigma_{Hlim} > 1200 \text{ N/mm}^2 (122 \text{ kgf/mm}^2, 1.74 \times 10^5 \text{ psi})$, $C_{ZL} = 0.91$.

and

ν_{40} = nominal kinematic viscosity of the oil at 40°C (104°F), mm²/s; see table below.

ν_{50} = nominal kinematic viscosity of the oil at 50°C (122°F), mm²/s; see table below.

ISO lubricant viscosity grade		VG 32 ⁽¹⁾	VG 46 ⁽¹⁾	VG 68 ⁽¹⁾	VG 100	VG 150	VG 220	VG 320
SI/MKS units	average viscosity ν_{40} mm ² /s	32	46	68	100	150	220	320
	average viscosity ν_{50} mm ² /s	21	30	43	61	89	125	180
US units	average viscosity ν_{40} in ² /s	0.0496	0.0713	0.1054	0.1550	0.2325	0.3410	0.4960
	average viscosity ν_{50} in ² /s	0.0326	0.0465	0.0667	0.0945	0.1380	0.1938	0.2790

1) Only for high speed (> 1400 rpm) transmission.

21.23.2 Speed Factor, Z_V

$$Z_V = C_{Zv} + \frac{2(1.0 - C_{Zv})}{\sqrt{0.8 + (32/\nu)}} \quad [\text{SI and MKS units}]$$

$$Z_V = C_{Zv} + \frac{2(1.0 - C_{Zv})}{\sqrt{0.8 + (6.4 \cdot 10^3/\nu)}} \quad [\text{US units}]$$

where σ_{Hlim} is the allowable stress number (contact) of the softer material.

For bevel gears, ν is to be substituted by ν_{mt} in the above formula.

a) with σ_{Hlim} in the range of:

$$850 \text{ N/mm}^2 (87 \text{ kgf/mm}^2, 1.23 \times 10^5 \text{ psi}) < \sigma_{Hlim} < 1200 \text{ N/mm}^2 (122 \text{ kgf/mm}^2, 1.74 \times 10^5 \text{ psi})$$

$$C_{Zv} = \left(0.08 \frac{\sigma_{Hlim} - 850}{350} \right) + 0.85 \quad [\text{SI units}]$$

$$C_{Zv} = \left(0.08 \frac{\sigma_{Hlim} - 87}{35.7} \right) + 0.85 \quad [\text{MKS units}]$$

$$C_{Zv} = \left(0.08 \frac{\sigma_{Hlim} - 1.23 \times 10^5}{5.076 \times 10^4} \right) + 0.85 \quad [\text{US units}]$$

b) with $\sigma_{Hlim} < 850 \text{ N/mm}^2 (87 \text{ kgf/mm}^2, 1.23 \times 10^5 \text{ psi})$, $C_{Zv} = 0.85$.

c) with $\sigma_{Hlim} > 1200 \text{ N/mm}^2 (122 \text{ kgf/mm}^2, 1.74 \times 10^5 \text{ psi})$, $C_{Zv} = 0.93$.

21.23.3 Roughness Factor, Z_R

$$Z_R = \left(\frac{3}{R_{Z10}} \right)^{C_{ZR}}$$

The peak-to-valley roughness, R_Z , is to be advised by the manufacturer or to be determined as a mean value of R_Z , measured on several tooth flanks of the pinion and the gear, as given by the following expression:

$$R_Z = \frac{R_{Zf1} + R_{Zf2}}{2}$$

Where roughness values are not available, roughness of the pinion $R_{Zf1} = 6.3 \mu\text{m} (248 \mu\text{in})$ and of the wheel $R_{Zf2} = 6.3 \mu\text{m} (248 \mu\text{in})$ may be used.

R_{Z10} is to be given by:

$$R_{Z10} = R_Z \sqrt[3]{\frac{10}{\rho_{red}}} \quad [\text{SI and MKS units}]$$

$$R_{Z10} = R_Z \sqrt[3]{\frac{6.4516 \cdot 10^{-6}}{\rho_{red}}} \quad [\text{US units}]$$

and the relative radius of curvature is to be given by:

$$\rho_{red} = \frac{\rho_1 \cdot \rho_2}{\rho_1 + \rho_2} \quad \text{for cylindrical gears}$$

$$\rho_{red} = \frac{\rho_{v1} \cdot \rho_{v2}}{\rho_{v1} + \rho_{v2}} \quad \text{for bevel gears}$$

$$\rho_1 = 0.5 \cdot d_{b1} \cdot \tan \alpha_{tw}$$

$$\rho_{v1} = 0.5 \cdot d_{vb1} \cdot \tan \alpha_{tw}$$

$$\rho_2 = 0.5 \cdot d_{b2} \cdot \tan \alpha_{tw}$$

$$\rho_{v2} = 0.5 \cdot d_{vb2} \cdot \tan \alpha_{tw}$$

If the stated roughness is an R_a value, also known as arithmetic average (AA) and centerline average (CLA), the following approximate relationship may be applied:

$$R_a = CLA = AA = R_{Zf} / 6$$

Where R_{Zf} is either R_{Zf1} for pinion or R_{Zf2} for gear and σ_{Hlim} is the allowable stress number (contact) of the softer material.

In the range of $850 \text{ N/mm}^2 \leq \sigma_{Hlim} \leq 1200 \text{ N/mm}^2$ ($87 \text{ kgf/mm}^2 \leq \sigma_{Hlim} \leq 122 \text{ kgf/mm}^2$; $1.23 \times 10^5 \text{ psi} \leq \sigma_{Hlim} \leq 1.74 \times 10^5 \text{ psi}$), C_{ZR} can be calculated as follows:

$$C_{ZR} = 0.32 - 2.00 \times 10^{-4} \cdot \sigma_{Hlim} \quad [\text{SI units}]$$

$$C_{ZR} = 0.32 - 1.96 \times 10^{-3} \cdot \sigma_{Hlim} \quad [\text{MKS units}]$$

$$C_{ZR} = 0.32 - 1.38 \times 10^{-6} \cdot \sigma_{Hlim} \quad [\text{US units}]$$

If $\sigma_{Hlim} < 850 \text{ N/mm}^2$ (87 kgf/mm^2 , $1.23 \times 10^5 \text{ psi}$), take $C_{ZR} = 0.150$

If $\sigma_{Hlim} > 1200 \text{ N/mm}^2$ (122 kgf/mm^2 , $1.74 \times 10^5 \text{ psi}$), take $C_{ZR} = 0.080$

21.25 Hardness Ratio Factor; Z_W

The hardness ratio factor, Z_{Wp} , accounts for the increase of surface durability of a soft steel gear when meshing with a surface hardened gear with a smooth surface.

The hardness ratio factor, Z_{Wp} , applies to the soft gear only and depends mainly on:

- Hardness of the soft gear
- Alloying elements of the soft gear
- Tooth flank roughness of the harder gear

$$Z_W = 1.2 - \frac{HB - 130}{1700}$$

where

HB = Brinell hardness of the softer material

$HV10$ = Vickers hardness with $F = 98.1$ N

For unalloyed steels

$HB \approx HV10 \approx U / 3.6$ [SI units]

$HB \approx HV10 \approx U / 0.367$ [MKS units]

$HB \approx HV10 \approx U / 522$ [US units]

For alloyed steels

$HB \approx HV10 \approx U / 3.4$ [SI units]

$HB \approx HV10 \approx U / 0.347$ [MKS units]

$HB \approx HV10 \approx U / 493$ [US units]

For $HB < 130$, $Z_w = 1.2$ is to be used.

For $HB > 470$, $Z_w = 1.0$ is to be used.

21.27 Size Factor, Z_x

The size factor, Z_x , accounts for the influence of tooth dimensions on permissible contact stress and reflects the non-uniformity of material properties.

The factor mainly depends on:

- Material and heat treatment
- Tooth and gear dimensions
- Ratio of case depth to tooth size
- Ratio of case depth to equivalent radius of curvature

For through-hardened gears and for surface-hardened gears with minimum required effective case depth including root of 1.14 mm (0.045 in.) relative to tooth size and radius curvature $Z_x = 1$. When the case depth is relatively shallow, then a smaller value of Z_x should be chosen.

The size factors, Z_x , are to be obtained from 4-3-1A1/Table 2.

21.29 Safety Factor for Contact Stress, S_H

Based on the application, the following safety factors for contact stress, S_H , are to be applied:

Main propulsion gears (including PTO):	1.40
Duplicated (or more) independent main propulsion gears (including azimuthing thrusters):	1.25
Main propulsion gears for yachts, single screw:	1.25
Main propulsion gears for yachts, multiple screw:	1.20
Auxiliary gears:	1.15

Note: For the above purposes, yachts are considered pleasure craft not engaged in trade or carrying passengers, and not intended for charter-service.

23 Tooth Root Bending Strength

The criterion for tooth root bending strength is the permissible limit of local tensile strength in the root fillet. The tooth root stress, σ_F , and the permissible tooth root stress, σ_{FP} , are to be calculated separately for the pinion and the wheel, whereby σ_F is not to exceed the permissible tooth root stress σ_{FP} .

The following formulas apply to gears having a rim thickness greater than 3.5 m and further for all involute basic rack profiles, with or without protuberance, however, with the following restrictions:

- The 30° tangents contact the tooth-root curve generated by the basic rack of the tool
- The basic rack of the tool has a root radius $\rho_{fp} > 0$
- The gear teeth are generated using a rack type tool.

23.1 Tooth Root Bending Stress for Pinion and Wheel

Cylindrical gears:

$$\sigma_{F1,2} = \frac{F_t}{b \cdot m_n} \cdot Y_F \cdot Y_S \cdot Y_\beta \cdot K_A \cdot K_\gamma \cdot K_v \cdot K_{Fa} \cdot K_{F\beta} \leq \sigma_{FP1,2} \quad \text{N/mm}^2, \text{ kgf/mm}^2, \text{ psi}$$

Bevel gears:

$$\sigma_{F1,2} = \frac{F_{mt}}{b \cdot m_{mn}} \cdot Y_{Fa} \cdot Y_{Sa} \cdot Y_\varepsilon \cdot Y_K \cdot Y_{LS} \cdot K_A \cdot K_\gamma \cdot K_v \cdot K_{Fa} \cdot K_{F\beta} \leq \sigma_{FP1,2} \quad \text{N/mm}^2, \text{ kgf/mm}^2, \text{ psi}$$

where

- Y_F, Y_{Fa} = tooth form factor, see 4-3-1A1/23.5 below
 Y_S, Y_{Sa} = stress correction factor, see 4-3-1A1/23.7 below
 Y_β = helix angle factor, see 4-3-1A1/23.9 below
 Y_ε = contact ratio factor, see 4-3-1A1/23.11 below
 Y_K = bevel gear factor, see 4-3-1A1/23.13 below
 Y_{LS} = load sharing factor, see 4-3-1A1/23.15 below

$F_t, F_{mt}, K_A, K_\gamma, K_v, K_{Fa}, K_{F\beta}, b, m_n, m_{mn}$, see 4-3-1A1/9, 4-3-1A1/11, 4-3-1A1/13, 4-3-1A1/15, 4-3-1A1/19, 4-3-1A1/17, 4-3-1A1/5, and 4-3-1A1/7 of this Appendix, respectively.

23.3 Permissible Tooth Root Bending Stress

$$\sigma_{FP1,2} = \frac{\sigma_{FE}}{S_F} \cdot Y_d \cdot Y_N \cdot Y_{\delta relT} \cdot Y_{RelT} \cdot Y_X \quad \text{N/mm}^2, \text{ kgf/mm}^2, \text{ psi}$$

where

- σ_{FE} = bending endurance limit, see 4-3-1A1/23.17 below
 Y_d = design factor, see 4-3-1A1/23.19 below
 Y_N = life factor, see 4-3-1A1/23.21 below
 $Y_{\delta relT}$ = relative notch sensitivity factor, see 4-3-1A1/23.23 below
 Y_{RelT} = relative surface factor, see 4-3-1A1/23.25 below
 Y_X = size factor, see 4-3-1A1/23.27 below
 S_F = safety factor for tooth root bending stress, see 4-3-1A1/23.29 below

23.5 Tooth Form Factor, Y_F , Y_{Fa}

The tooth form factors, Y_F and Y_{Fa} , represent the influence on nominal bending stress of the tooth form with load applied at the outer point of single pair tooth contact.

The tooth form factors, Y_F and Y_{Fa} , are to be determined separately for the pinion and the wheel. In the case of helical gears, the form factors for gearing are to be determined in the normal section, i.e., for the virtual spur gear with virtual number of teeth, z .

Cylindrical gears:

$$Y_F = \frac{6 \cdot (h_F / m_n) \cdot \cos \alpha_{Fen}}{(s_{Fn} / m_n)^2 \cdot \cos \alpha_n}$$

Bevel gears:

$$Y_{Fa} = \frac{6 \cdot (h_{Fa} / m_{mn}) \cdot \cos \alpha_{Fan}}{(s_{Fn} / m_{mn})^2 \cdot \cos \alpha_n}$$

where

h_F, h_{Fa} = bending moment arm for tooth root bending stress for application of load at the outer point of single tooth pair contact; mm (in.)

s_{Fn} = width of tooth at highest stressed section; mm (in.)

$\alpha_{Fen}, \alpha_{Fan}$ = normal load pressure angle at tip of tooth; degrees

For determination of h_F, h_{Fa}, s_{Fn} and $\alpha_{Fen}, \alpha_{Fan}$, see 4-3-1A1/23.5.1, 4-3-1A1/23.5.2, 4-3-1A1/23.5.3 below and 4-3-1A1/Figure 1.

23.5.1 External Gears

Width of tooth, s_{Fn} , at tooth-root normal chord:

$$\frac{s_{Fn}}{m_n} = z_n \cdot \sin\left(\frac{\pi}{3} - \vartheta\right) + \sqrt{3} \cdot \left(\frac{G}{\cos \vartheta} - \frac{\rho_{a0}}{m_n}\right)$$

$$\vartheta = 2 \cdot \frac{G}{z_n} \cdot \tan \vartheta - H \quad \text{degrees; to be solved iteratively}$$

$$G = \frac{\rho_{a0}}{m_n} - \frac{h_{a0}}{m_n} + x$$

$$H = \frac{2}{z_n} \cdot \left(\frac{\pi}{2} - \frac{E}{m_n}\right) - \frac{\pi}{3} \quad \text{[SI and MKS units]}$$

$$H = \frac{2}{z_n} \cdot \left(\frac{\pi}{2} - \frac{E}{25.4 \cdot m_n}\right) - \frac{\pi}{3} \quad \text{[US units]}$$

$$z_n = \frac{z}{\cos^2 \beta_b \cdot \cos \beta}$$

$$\beta_b = \arccos \sqrt{1 - (\sin \beta \cdot \cos \alpha_n)^2} \quad \text{degrees}$$

$$E = \frac{\pi}{4} \cdot m_n - h_{a0} \cdot \tan \alpha_n + \frac{S_{pr}}{\cos \alpha_n} - (1 - \sin \alpha_n) \cdot \frac{\rho_{a0}}{\cos \alpha_n} \quad \text{[SI and MKS units]}$$

$$E = 25.4 \cdot \left(\frac{\pi}{4} \cdot m_n - h_{a0} \cdot \tan \alpha_n + \frac{S_{pr}}{\cos \alpha_n} - (1 - \sin \alpha_n) \cdot \frac{\rho_{a0}}{\cos \alpha_n}\right) \quad \text{[US units]}$$

$$S_{pr} = p_{r0} - q$$

$$S_{pr} = 0 \quad \text{when gears are not undercut (non-protuberance hob)}$$

where:

E , h_{a0} , α_n , S_{pr} , p_{r0} , q and ρ_{a0} are shown in 4-3-1A1/Figure 2.

$$h_{a0} = \text{addendum of tool; mm (in.)}$$

$$S_{pr} = \text{residual undercut left by protuberance; mm (in.)}$$

$$p_{r0} = \text{protuberance of tool; mm (in.)}$$

$$q = \text{material allowances for finish machining; mm (in.)}$$

$$\rho_{a0} = \text{tip radius of tool; mm (in.)}$$

$$z_n = \text{virtual number of teeth}$$

$$x = \text{addendum modification coefficient}$$

$$\alpha_{Fen} = \text{angle for application of load at the highest point of single tooth contact}$$

$$\alpha_{en} = \text{pressure angle at the highest point of single tooth contact}$$

Bending moment arm h_F :

$$\frac{h_F}{m_n} = \frac{1}{2} \cdot \left[(\cos \gamma_e - \sin \gamma_e \cdot \tan \alpha_{Fen}) \cdot \frac{d_{en}}{m_n} - z_n \cdot \cos \left(\frac{\pi}{3} - \vartheta \right) - \frac{G}{\cos \vartheta} + \frac{\rho_{a0}}{m_n} \right]$$

$$\frac{\rho_F}{m_n} = \frac{\rho_{a0}}{m_n} + \frac{2 \cdot G^2}{\cos \vartheta \cdot (z_n \cos^2 \vartheta - 2G)}$$

where

$$\rho_F = \text{root fillet radius in the critical section at } 30^\circ \text{ tangent; mm (in.); see 4-3-1A1/Figure 1.}$$

Normal load pressure angle at tip of tooth, α_{Fen} , α_{Fan} :

$$\alpha_{Fen} = \alpha_{en} - \gamma_e \quad \text{degrees}$$

$$\alpha_{en} = \arccos \left(\frac{d_{bn}}{d_{en}} \right) \quad \text{degrees}$$

$$\gamma_e = \left(\frac{0.5 \cdot \pi + 2 \cdot x \cdot \tan \alpha_n}{z_n} + \text{inv } \alpha_n - \text{inv } \alpha_{en} \right) \cdot \frac{180}{\pi} \quad \text{degrees}$$

$$d_{an1} = d_{n1} + d_{a1} - d_1 \quad \text{mm (in.)}$$

$$d_{an2} = d_{n2} + d_{a2} - d_2 \quad \text{mm (in.)}$$

$$d_{n1,2} = z_{n1,2} \cdot m_n \quad \text{mm (in.)}$$

$$d_{bn1,2} = d_{n1,2} \cdot \cos \alpha_n \quad \text{mm (in.)}$$

$$d_{en1} = \frac{2 \cdot z_1}{|z_1|} \cdot \sqrt{\left[\sqrt{\left(\frac{d_{an1}}{2} \right)^2 - \left(\frac{d_{bn1}}{2} \right)^2} - \frac{\pi \cdot d_1 \cdot \cos \beta \cdot \cos \alpha_n}{|z_1|} \cdot (\varepsilon_{an} - 1) \right]^2 + \left(\frac{d_{bn1}}{2} \right)^2} \quad \text{mm (in.)}$$

$$d_{en2} = \frac{2 \cdot z_2}{|z_2|} \cdot \sqrt{\left[\sqrt{\left(\frac{d_{an2}}{2} \right)^2 - \left(\frac{d_{bn2}}{2} \right)^2} - \frac{\pi \cdot d_2 \cdot \cos \beta \cdot \cos \alpha_n}{|z_2|} \cdot (\varepsilon_{an} - 1) \right]^2 + \left(\frac{d_{bn2}}{2} \right)^2} \quad \text{mm (in.)}$$

$$\varepsilon_{an} = \frac{\varepsilon_\alpha}{\cos^2 \beta_b} \quad \text{degrees}$$

Note: z_1, z_2 are positive for external gears and negative for internal gears.

23.5.2 Internal Gears

The tooth form factor of a special rack can be substituted as an approximate value of the form of an internal gear. The profile of such a rack should be a version of the basic rack profile, so modified that it would generate the normal profile, including tip and root circles, of an exact counterpart of the internal gear. The tip load angle is $\alpha_{Fen} = \alpha_n$.

Width of tooth, s_{Fn2} , at tooth-root normal chord:

$$\frac{s_{Fn2}}{m_n} = 2 \cdot \left[\frac{\pi}{4} + \tan \alpha_n \cdot \left(\frac{h_{fp2} - \rho_{fp2}}{m_n} \right) + \frac{\rho_{fp2} - S_{pr2}}{m_n \cdot \cos \alpha_n} - \frac{\rho_{fp2}}{m_n} \cdot \cos \frac{\pi}{6} \right]$$

Bending moment arm h_{F2} :

$$\frac{h_{F2}}{m_n} = \frac{d_{en2} - d_{fn2}}{2 \cdot m_n} - \left[\frac{\pi}{4} + \left(\frac{h_{fp2}}{m_n} - \frac{d_{en2} - d_{fn2}}{2 \cdot m_n} \right) \cdot \tan \alpha_n \right] \cdot \tan \alpha_n - \frac{\rho_{fp2}}{m_n} \cdot \left(1 - \sin \frac{\pi}{6} \right)$$

$$d_{fn2} = d_{n2} + d_{f2} - d_2 \quad \text{mm (in.)}$$

$$h_{fp2} = \frac{d_{n2} - d_{fn2}}{2} \quad \text{mm (in.)}$$

$$\rho_{fp2} = \rho_{F2} = \frac{\rho_{a02}}{2} \quad \text{mm (in.)}$$

Note: In the case of a full root fillet $\rho_{F2} = \rho_{a02}$ is to be used, or as an approximation:

$$\rho_{a02} = 0.30 \cdot m_n \quad \text{mm (in.)}$$

$$\rho_{fp2} = \rho_{F2} = 0.15 \cdot m_n \quad \text{mm (in.)}$$

$$h_{f2} = (1.25 \dots 1.30) \cdot m_n \quad \text{mm (in.)}$$

$$\rho_{fp2} = \frac{c_p}{1 - \sin \alpha_n} = \frac{h_{f2} - h_{Nf2}}{1 - \sin \alpha_n} = \frac{d_{Nf2} - d_{f2}}{2 \cdot (1 - \sin \alpha_n)} \quad \text{mm (in.)}$$

where

d_{f2} = root diameter of wheel; mm (in.); see 4-3-1A1/Figure 1.

d_{Nf2}, h_{Nf2} = is the diameter, dedendum of basic rack at which the usable flank and root fillet of the annulus gear meet; mm (in.)

c_p = is the bottom clearance between basic rack and mating profile; mm (in.)

Note: The diameters d_{n2} and d_{en2} are to be calculated with the same formulas as for external gears.

23.5.3 Bevel Gears

Width of tooth, s_{Fn} , at tooth-root normal chord:

$$\frac{s_{Fn}}{m_{mn}} = z_{vn} \cdot \sin\left(\frac{\pi}{3} - \vartheta\right) + \sqrt{3} \cdot \left(\frac{G}{\cos \vartheta} - \frac{\rho_{a0}}{m_{mn}}\right)$$

$$\vartheta = 2 \cdot \frac{G}{z_{vn}} \cdot \tan \vartheta - H \quad \text{degrees; to be solved iteratively}$$

$$G = \frac{\rho_{a0}}{m_{mn}} - \frac{h_{a0}}{m_{mn}} + x_{hm}$$

$$H = \frac{2}{z_{vn}} \cdot \left(\frac{\pi}{2} - \frac{E}{m_{mn}}\right) - \frac{\pi}{3} \quad \text{[SI and MKS units]}$$

$$H = \frac{2}{z_{vn}} \cdot \left(\frac{\pi}{2} - \frac{E}{25.4 \cdot m_{mn}}\right) - \frac{\pi}{3} \quad \text{[US units]}$$

$$E = \frac{\pi}{4} \cdot m_{mn} - x_{sm} \cdot m_{mn} - h_{a0} \cdot \tan \alpha_n + \frac{S_{pr}}{\cos \alpha_n} - (1 - \sin \alpha_n) \cdot \frac{\rho_{a0}}{\cos \alpha_n} \quad \text{[SI and MKS units]}$$

$$E = 25.4 \cdot \left(\frac{\pi}{4} \cdot m_{mn} - x_{sm} \cdot m_{mn} - h_{a0} \cdot \tan \alpha_n + \frac{S_{pr}}{\cos \alpha_n} - (1 - \sin \alpha_n) \cdot \frac{\rho_{a0}}{\cos \alpha_n}\right) \quad \text{[US units]}$$

$$S_{pr} = p_{r0} - q$$

$$S_{pr} = 0 \quad \text{when gears are not undercut (non-protuberance hob)}$$

where:

E , h_{a0} , α_n , S_{pr} , p_{r0} , q and ρ_{a0} are shown in 4-3-1A1/Figure 2.

h_{a0} = addendum of tool; mm (in.)

S_{pr} = residual undercut left by protuberance; mm (in.)

p_{r0} = protuberance of tool; mm (in.)

q = machining allowances; mm (in.)

ρ_{a0} = tip radius of tool; mm (in.)

z_{vn} = virtual number of teeth

x_{hm} = profile shift coefficient

x_{sm} = tooth thickness modification coefficient (midface)

α_{Fan} = angle for application of load at the highest point of single tooth contact

α_{an} = pressure angle at the highest point of single tooth contact

Bending moment arm h_{Fa} :

$$\frac{h_{Fa}}{m_{mn}} = \frac{1}{2} \cdot \left[(\cos \gamma_a - \sin \gamma_a \cdot \tan \alpha_{Fan}) \cdot \frac{d_{van}}{m_{mn}} - z_{vn} \cdot \cos\left(\frac{\pi}{3} - \vartheta\right) - \frac{G}{\cos \vartheta} + \frac{\rho_{a0}}{m_{mn}} \right]$$

$$\frac{\rho_F}{m_{mn}} = \frac{\rho_{a0}}{m_{mn}} + \frac{2 \cdot G^2}{\cos \vartheta \cdot (z_{vn} \cdot \cos^2 \vartheta - 2 \cdot G)}$$

where

ρ_F = root fillet radius in the critical section at 30° tangent; mm (mm, in.); see 4-3-1A1/Figure 1.

Normal load pressure angle at tip of tooth α_{Fan} , α_{an} :

$$\alpha_{Fan} = \alpha_{an} - \gamma_a \quad \text{degrees}$$

$$\alpha_{an} = \arccos\left(\frac{d_{vbn}}{d_{van}}\right) \quad \text{degrees}$$

$$\gamma_a = \left(\frac{0.5 \cdot \pi + 2 \cdot (x_{hm} \cdot \tan \alpha_n + x_{sm})}{z_{vn}} + \text{inv} \alpha_n - \text{inv} \alpha_{an} \right) \cdot \frac{180}{\pi} \quad \text{degrees}$$

$$\beta_{bm} = \arccos \sqrt{1 - (\sin \beta_m \cdot \cos \alpha_n)^2} \quad \text{degrees}$$

(See also 4-3-1A1/7 of this Appendix.)

$$d_{van1} = d_{vn1} + d_{va1} - d_{v1} \quad \text{mm (in.)}$$

$$d_{van2} = d_{vn2} + d_{va2} - d_{v2} \quad \text{mm (in.)}$$

$$d_{vn1} = z_{vn1} \cdot m_{mn} \quad \text{mm (in.)}$$

$$d_{vn2} = z_{vn2} \cdot m_{mn} \quad \text{mm (in.)}$$

$$d_{vbn1} = d_{vn1} \cdot \cos \alpha_n \quad \text{mm (in.)}$$

$$d_{vbn2} = d_{vn2} \cdot \cos \alpha_n \quad \text{mm (in.)}$$

23.7 Stress Correction Factor, Y_S , Y_{Sa}

The stress correction factors, Y_S and Y_{Sa} , are used to convert the nominal bending stress to the local tooth root stress.

Y_S applies to the load application at the outer point of single tooth pair contact. Y_S is to be determined for pinion and wheel, separately.

For notch parameter q_s within a range of ($1 \leq q_s < 8$):

$$q_s = \frac{s_{Fn}}{2 \cdot \rho_F}$$

Cylindrical gears:

$$Y_S = (1.2 + 0.13 \cdot L) \cdot q_s^{\left(\frac{1}{1.21 + (2.3/L)} \right)}$$

Bevel gears:

$$Y_{Sa} = (1.2 + 0.13 \cdot L_a) \cdot q_s^{\left(\frac{1}{1.21 + (2.3/L_a)} \right)}$$

where:

ρ_F = root fillet radius in the critical section at 30° tangent mm (in.)

L = s_{Fn}/h_F for cylindrical gears

L_a = s_{Fn}/h_{Fa} for bevel gears

h_F , h_{Fa} , s_{Fn} , ρ_F see 4-3-1A1/Figure 3.

23.9 Helix Angle Factor, Y_β

The helix angle factor, Y_β , converts the stress calculated for a point loaded cantilever beam representing the substitute gear tooth to the stress induced by a load along an oblique load line into a cantilever plate which represents a helical gear tooth.

$$Y_\beta = 1 - \varepsilon_\beta \cdot \frac{\beta}{120}$$

where:

β = reference helix angle in degrees for cylindrical gears.

$\varepsilon_\beta > 1.0$ a value of 1.0 is to be substituted for ε_β

$\beta > 30^\circ$ an angle of 30° is to be substituted for β

23.11 Contact Ratio Factor, Y_ε

The contact factor, Y_ε , covers the conversion from load application at the tooth tip to the load application for bevel gears.

$$Y_\varepsilon = 0.25 + \frac{0.75}{\varepsilon_\alpha}; \text{ for } \varepsilon_\beta = 0$$

$$Y_\varepsilon = 0.25 + \frac{0.75}{\varepsilon_\alpha} - \left(\frac{0.75}{\varepsilon_\alpha} - 0.375 \right) \cdot \varepsilon_\beta; \text{ for } 0 < \varepsilon_\beta < 1$$

$$Y_\varepsilon = 0.625; \text{ for } \varepsilon_\beta \geq 1$$

23.13 Bevel Gear Factor, Y_K

The bevel gear factor, Y_K , accounts for the differences between bevel and cylindrical gears.

$$Y_K = \frac{1}{2} + \frac{b}{4 \cdot \ell'_{bm}} + \frac{\ell'_{bm}}{4 \cdot b}$$

$$\ell'_{bm} = \ell_{bm} \cdot \cos \beta_{vb}$$

23.15 Load Sharing Factor, Y_{LS}

The load sharing factor, Y_{LS} , accounts for the differences between two or more pair of teeth for $\varepsilon_\gamma > 2$.

$$Y_{LS} = Z_{LS}^2 \geq 0.7$$

for Z_{LS} , see 4-3-1A1/21.13 of this appendix.

23.17 Allowable Stress Number (Bending), σ_{FE}

For a given material, σ_{FE} is the limit of repeated tooth root stress that can be sustained. For most materials, their stress cycles may be taken at 3×10^6 as the beginning of the endurance limit, unless otherwise specified.

The endurance limit, σ_{FE} , is defined as the unidirectional pulsating stress with a minimum stress of zero (disregarding residual stresses due to heat treatment). Other conditions such as e.g., alternating stress or prestressing are covered by the design factor Y_d .

The endurance limit mainly depends on:

- Material composition, cleanliness and defects
- Mechanical properties
- Residual stress

- Hardening process, depth of hardened zone, hardness gradient
- Material structure (forged, rolled bar, cast)

The σ_{FE} values are to correspond to a failure probability of 1% or less. The values of σ_{FE} are to be determined from 4-3-1A1/Table 3 or to be advised by the manufacturer, together with technical justification for the proposed values. For gears treated with controlled shot peening process, the value, σ_{FE} , may be increased by 10%.

23.19 Design Factor, Y_d

The design factor, Y_d , takes into account the influence of load reversing and shrink fit prestressing on the tooth root strength, relative to the tooth root strength with unidirectional load as defined for σ_{FE} .

$$Y_d = 1.0 \text{ in general;}$$

$$Y_d = 0.9 \text{ for gears with part load in reversed direction, such as main wheel in reversing gearboxes;}$$

$$Y_d = 0.7 \text{ for idler gears.}$$

23.21 Life Factor, Y_N

The life factor, Y_N , accounts for the higher permissible tooth root bending stress in case a limited life (number of load cycles) is specified.

The factor mainly depends on:

- Material and hardening
- Number of cycles
- Influence factors ($Y_{\delta relT}$, Y_{RrelT} , Y_X)

The life factor, Y_N , can be determined from 4-3-1A1/Table 5.

23.23 Relative Notch Sensitivity Factor, $Y_{\delta relT}$

The relative notch sensitivity factor, $Y_{\delta relT}$, indicates the extent to which the theoretically concentrated stress lies above the fatigue endurance limit.

The factor mainly depends on the material and relative stress gradient.

For notch parameter values within the range of $1.5 \leq q_s < 4$, $Y_{\delta relT} = 1.0$

For $q_s < 1.5$, $Y_{\delta relT} = 0.95$

For notch parameter $q_s \geq 4$, $Y_{\delta relT}$ can be determined by the methods outlined in ISO 6336-3, Section 11 Sensitivity factors, Y_{δ} , $Y_{\delta T}$, $Y_{\delta \kappa}$ and relative notch sensitivity factors, $Y_{\delta relT}$, $Y_{\delta relk}$.

23.25 Relative Surface Factor, Y_{RrelT}

The relative surface factor, Y_{RrelT} , as given in the following table, takes into account the dependence of the tooth root bending strength on the surface condition in the tooth root fillet, but mainly the dependence on the peak to valley surface roughness.

	$R_{zr} < 1 \mu\text{m}$	SI & MKS units	US units
	$R_{zr} < 39 \mu\text{in}$	$1 \mu\text{m} \leq R_{zr} \leq 40 \mu\text{m}$	$39 \mu\text{in} \leq R_{zr} \leq 1575 \mu\text{in}$
Case hardened steels, through - hardened steels $U \geq 800 \text{ N/mm}^2$ (82 kgf/mm ² , $1.16 \times 10^5 \text{ psi}$)	1.120	$1.675 - 0.53 \cdot (R_{zr} + 1)^{0.1}$	$1.675 - 0.53 \cdot (0.0254 \cdot R_{zr} + 1)^{0.1}$
Normalized steels $U < 800 \text{ N/mm}^2$ (82 kgf/mm ² , $1.16 \times 10^5 \text{ psi}$)	1.070	$5.3 - 4.2 \cdot (R_{zr} + 1)^{0.01}$	$5.3 - 4.2 \cdot (0.0254 \cdot R_{zr} + 1)^{0.01}$
Nitrided steels	1.025	$4.3 - 3.26 \cdot (R_{zr} + 1)^{0.005}$	$4.3 - 3.26 \cdot (0.0254 \cdot R_{zr} + 1)^{0.005}$
R_{zr} = mean peak to-valley roughness of tooth root fillets; μm (μm , μin)			

This method is only applicable where scratches or similar defects deeper than $2R_{zr}$ are not present.

If the stated roughness is an R_a value, also known as arithmetic average (AA) and centerline average (CLA), the following approximate relationship may be applied:

$$R_a = CLA = AA = R_{zr} / 6$$

23.27 Size Factor (Root), Y_X

The size factor (root), Y_X , takes into account the decrease of the strength with increasing size.

The factor mainly depends on:

- Material and heat treatment
- Tooth and gear dimensions
- Ratio of case depth to tooth size

<i>SI and MKS units</i>		
$Y_X = 1.00$	for $m_n \leq 5$	Generally
$Y_X = 1.03 - 0.006 \cdot m_n$	for $5 < m_n < 30$	Normalized and through tempered- hardened steels
$Y_X = 0.85$	for $m_n \geq 30$	
$Y_X = 1.05 - 0.010 \cdot m_n$	for $5 < m_n < 25$	Surface hardened steels
$Y_X = 0.80$	for $m_n \geq 25$	
<i>US units</i>		
$Y_X = 1.00$	for $m_n \leq 0.1968$	Generally
$Y_X = 1.03 - 0.1524 \cdot m_n$	for $0.1968 < m_n < 1.181$	Normalized and through tempered- hardened steels
$Y_X = 0.85$	for $m_n \geq 1.181$	
$Y_X = 1.05 - 0.254 \cdot m_n$	for $0.1968 < m_n < 0.9842$	Surface hardened steels
$Y_X = 0.80$	for $m_n \geq 0.9842$	

Note: For Bevel gears, the m_n (normal module) is to be substituted by m_{mn} (normal module at mid-facewidth).

23.29 Safety Factor for Tooth Root Bending Stress, S_F

Based on the application, the following safety factors for tooth root bending stress, S_F , are to be applied:

Main propulsion gears (including PTO):	1.80
Duplicated (or more) independent main propulsion gears (including azimuthing thrusters):	1.60
Main propulsion gears for yachts, single screw:	1.50
Main propulsion gears for yachts, multiple screw:	1.45
Auxiliary gears:	1.40

Note: For the above purposes, yachts are considered pleasure craft not engaged in trade or carrying passengers, and not intended for charter-service.

TABLE 1
Values of the Elasticity Factor Z_E and Young’s Modulus of Elasticity E

(Ref. 4-3-1A1/21.9)

The value of E for combination of different materials for pinion and wheel is to be calculated by:

$$E = \frac{2 \cdot E_1 \cdot E_2}{E_1 + E_2}$$

<i>SI units</i>						
Pinion			Wheel			
Material	Young’s Modulus of elasticity E_1 N/mm ²	Poisson’s ratio ν	Material	Young’s Modulus of elasticity E_2 N/mm ²	Poisson’s ratio ν	Elasticity Factor Z_E N ^{1/2} /mm
Steel	206000	0.3	Steel	206000	0.3	189.8
			Cast steel	202000		188.9
			Nodular cast iron	173000		181.4
			Cast tin bronze	103000		155.0
			Tin bronze	113000		159.8
			Lamellar graphite cast iron (gray cast iron)	126000 to 118000		165.4 to 162.0
Cast steel	202000	0.3	Cast steel	202000	188.0	
			Nodular cast iron	173000	180.5	
			Lamellar graphite cast iron (gray cast iron)	118000	161.4	
Nodular cast iron	173000	0.3	Nodular cast iron	173000	173.9	
			Lamellar graphite cast iron (gray cast iron)	118000	156.6	
Lamellar graphite cast iron (gray cast iron)	126000 to 118000	0.3	Lamellar graphite cast iron (gray cast iron)	118000	0.3	146.0 to 143.7
Steel	206000	0.3	Nylon	7850 (mean value)	0.5	56.4

continued....

TABLE 1 (continued)
Values of the Elasticity Factor Z_E and Young's Modulus of Elasticity E

<i>MKS units</i>						
Pinion			Wheel			
Material	Young's Modulus of elasticity E_1 kgf/mm ²	Poisson's ratio ν	Material	Young's Modulus of elasticity E_2 kgf/mm ²	Poisson's ratio ν	Elasticity Factor Z_E kgf ^{1/2} /mm
Steel	2.101×10^4	0.3	Steel	2.101×10^4	0.3	60.609
			Cast steel	2.060×10^4		60.321
			Nodular cast iron	1.764×10^4		57.926
			Cast tin bronze	1.050×10^4		49.496
			Tin bronze	1.152×10^4		51.029
			Lamellar graphite cast iron (gray cast iron)	1.285×10^4 to 1.203×10^4		52.817 to 51.731
Cast steel	2.060×10^4	0.3	Cast steel	2.060×10^4	0.3	60.034
			Nodular cast iron	1.764×10^4		57.639
			Lamellar graphite cast iron (gray cast iron)	1.203×10^4		51.540
Nodular cast iron	1.764×10^4	0.3	Nodular cast iron	1.764×10^4	0.3	55.531
			Lamellar graphite cast iron (gray cast iron)	1.203×10^4		50.007
Lamellar graphite cast iron (gray cast iron)	1.285×10^4 to 1.203×10^4	0.3	Lamellar graphite cast iron (gray cast iron)	1.203×10^4	0.3	46.622 to 45.888
Steel	2.101×10^4	0.3	Nylon	800.477 (mean value)	0.5	18.010

continued.....

TABLE 1 (continued)
Values of the Elasticity Factor Z_E and Young's Modulus of Elasticity E

<i>US units</i>						
Pinion			Wheel			
Material	Young's Modulus of elasticity E_1 psi	Poisson's ratio ν	Material	Young's Modulus of elasticity E_2 psi	Poisson's ratio ν	Elasticity factor Z_E lbf ^{1/2} /in
Steel	2.988×10^7	0.3	Steel	2.988×10^7	0.3	2.286×10^3
			Cast steel	2.930×10^7		2.275×10^3
			Nodular cast iron	2.509×10^7		2.185×10^3
			Cast tin bronze	1.494×10^7		1.867×10^3
			Tin bronze	1.639×10^7		1.924×10^3
			Lamellar graphite cast iron (gray cast iron)	1.827×10^7 to 1.711×10^7		1.992×10^3 to 1.951×10^3
Cast steel	2.930×10^7	0.3	Cast steel	2.930×10^7	0.3	2.264×10^3
			Nodular cast iron	2.509×10^7		2.174×10^3
			Lamellar graphite cast iron (gray cast iron)	1.711×10^7		1.944×10^3
Nodular cast iron	2.509×10^7	0.3	Nodular cast iron	2.509×10^7	0.3	2.094×10^3
			Lamellar graphite cast iron (gray cast iron)	1.711×10^7		1.886×10^3
Lamellar graphite cast iron (gray cast iron)	1.827×10^7 to 1.711×10^7	0.3	Lamellar graphite cast iron (gray cast iron)	1.711×10^7	0.3	1.758×10^3 to 1.731×10^3
Steel	2.988×10^7	0.3	Nylon	1.139×10^6 (mean value)	0.5	679.234

TABLE 2
Size Factor Z_X for Contact Stress
(Ref. 4-3-1A1/21.27)

SI and MKS units	
Z_X , size factor for contact stress	Material
1.0	For through-hardened pinion treatment All modules (m_n)
1.0 1.05 – 0.005 m_n 0.9	For carburized and induction-hardened pinion heat treatment $m_n \leq 10$ $m_n < 30$ $m_n \geq 30$
1.0 1.08 – 0.011 m_n 0.75	For nitrided pinion treatment $m_n < 7.5$ $m_n < 30$ $m_n \geq 30$
For <i>Bevel gears</i> , the m_n (normal module) is to be substituted by m_{mn} (normal module at mid-facewidth).	

US units	
Z_X , size factor for contact stress	Material
1.0	For through-hardened pinion treatment All modules (m_n)
1.0 1.05 – 0.127 m_n 0.9	For carburized and induction-hardened pinion heat treatment $m_n \leq 0.394$ $m_n < 1.181$ $m_n \geq 1.181$
1.0 1.08 – 0.279 m_n 0.75	For nitrided pinion treatment $m_n < 0.295$ $m_n < 1.181$ $m_n \geq 1.181$
For <i>Bevel gears</i> , the m_n (normal module) is to be substituted by m_{mn} (normal module at mid-facewidth).	

TABLE 3
Allowable Stress Number (contact) σ_{Hlim} and
Allowable Stress Number (bending) σ_{FE}

(Ref. 4-3-1A1/21.19, 4-3-1A1/23.17)

<i>SI units</i>	$\sigma_{Hlim} N/mm^2$	$\sigma_{FE} N/mm^2$	<i>Reference Standard ISO 6336-5:1996(E) ISO Figure and Material Quality</i>
Case hardened (carburized) CrNiMo steels: of ordinary grade; of specially approved high quality grade (to be based on review and verification of established testing procedure).	1500 1650	920 1050	Fig. 9, MQ Fig. 11, MQ ⁽¹⁾ Fig. 9, ME Fig. 11, ME ⁽²⁾
Other case hardened (carburized) steels	1500	840	Fig. 9, MQ Fig. 11, MQ ⁽³⁾
Gas nitrided steels: hardened, tempered and gas nitrided, Surface hardness: 700-850 HV10	1250	920	Fig. 13a, MQ Fig. 14a, MQ
Through hardened steels: hardened, tempered and gas nitrided, Surface hardness: 500-650 HV10	1000	740	Fig. 13b, MQ Fig. 14b, MQ
Through hardened steels: hardened, tempered or normalized and nitro-carburized, Surface hardness: 450-650 HV10	950	780	Fig. 13c, ME-MQ Fig. 14c, ME-MQ
Flame or induction hardened steels, Surface hardness: 520-620 HV10	$0.65 \cdot HV10 + 830$	$0.25 \cdot HV10 + 580$	Fig. 10, MQ Fig. 12, MQ
Alloyed through hardening steels, Surface hardness: 195-360 HV10	$1.32 \cdot HV10 + 372$	$0.78 \cdot HV10 + 400$	Fig. 5, MQ Fig. 7, MQ
Through hardened carbon steels, Surface hardness: 135-210 HV10	$1.05 \cdot HV10 + 335$	$0.50 \cdot HV10 + 320$	Fig. 5, Carbon steel, MQ Fig. 7, Carbon steel, MQ
Alloyed cast steels, Surface hardness: 198-358 HV10	$1.30 \cdot HV10 + 295$	$0.68 \cdot HV10 + 325$	Fig. 6, MQ-ML Fig. 8, MQ-ML
Cast carbon steels, Surface hardness: 135-210 HV10	$0.87 \cdot HV10 + 290$	$0.50 \cdot HV10 + 225$	Fig. 6, Carbon steel, MQ-ML Fig. 8, Carbon steel, MQ-ML

TABLE 3 (continued)
Allowable Stress Number (contact) σ_{Hlim} and
Allowable Stress Number (bending) σ_{FE}

<i>MKS units</i>	σ_{Hlim} kgf/mm ²	σ_{FE} kgf/mm ²	<i>Reference Standard ISO 6336-5:1996(E) ISO Figure and Material Quality</i>
Case hardened (carburized) CrNiMo steels: of ordinary grade;	153.0	93.8	Fig. 9, MQ Fig. 11, MQ ⁽¹⁾
of specially approved high quality grade (to be based on review and verification of established testing procedure).	168.3	107.1	Fig. 9, ME Fig. 11, ME ⁽²⁾
Other case hardened (carburized) steels	153.0	85.7	Fig. 9, MQ Fig. 11, MQ ⁽³⁾
Gas nitrided steels: hardened, tempered and gas nitrided, Surface hardness: 700-850 HV10	127.5	93.8	Fig. 13a, MQ Fig. 14a, MQ
Through hardened steels: hardened, tempered and gas nitrided, Surface hardness: 500-650 HV10	102.0	75.5	Fig. 13b, MQ Fig. 14b, MQ
Through hardened steels: hardened, tempered or normalized and nitro-carburized, Surface hardness: 450-650 HV10	96.9	79.5	Fig. 13c, ME-MQ Fig. 14c, ME-MQ
Flame or induction hardened steels, Surface hardness: 520-620 HV10	$0.0663 \cdot HV10 + 84.6$	$0.0255 \cdot HV10 + 59.1$	Fig. 10, MQ Fig. 12, MQ
Alloyed through hardening steels, Surface hardness: 195-360 HV10	$0.1346 \cdot HV10 + 37.9$	$0.0795 \cdot HV10 + 40.8$	Fig. 5, MQ Fig. 7, MQ
Through hardened carbon steels, Surface hardness: 135-210 HV10	$0.1071 \cdot HV10 + 34.2$	$0.0510 \cdot HV10 + 32.6$	Fig. 5, Carbon steel, MQ Fig. 7, Carbon steel, MQ
Alloyed cast steels, Surface hardness: 198-358 HV10	$0.1326 \cdot HV10 + 30.1$	$0.0693 \cdot HV10 + 33.1$	Fig. 6, MQ-ML Fig. 8, MQ-ML
Cast carbon steels, Surface hardness: 135-210 HV10	$0.0887 \cdot HV10 + 29.6$	$0.0510 \cdot HV10 + 22.9$	Fig. 6, Carbon steel, MQ-ML Fig. 8, Carbon steel, MQ-ML

TABLE 3 (continued)
Allowable Stress Number (contact) σ_{Hlim} and
Allowable Stress Number (bending) σ_{FE}

<i>US units</i>	<i>σ_{Hlim} psi</i>	<i>σ_{FE} psi</i>	<i>Reference Standard ISO 6336-5:1996(E) ISO Figure and Material Quality</i>
Case hardened (carburized) CrNiMo steels: of ordinary grade; of specially approved high quality grade (to be based on review and verification of established testing procedure).	217557	133435	Fig. 9, MQ Fig. 11, MQ ⁽¹⁾
	239312	152290	Fig. 9, ME Fig. 11, ME ⁽²⁾
Other case hardened (carburized) steels	217557	121832	Fig. 9, MQ Fig. 11, MQ ⁽³⁾
Gas nitrided steels: hardened, tempered and gas nitrided, Surface hardness: 700-850 HV10	181297	133435	Fig. 13a, MQ Fig. 14a, MQ
Through hardened steels: hardened, tempered and gas nitrided, Surface hardness: 500-650 HV10	145038	107328	Fig. 13b, MQ Fig. 14b, MQ
Through hardened steels: hardened, tempered or normalized and nitro-carburized, Surface hardness: 450-650 HV10	137786	113129	Fig. 13c, ME-MQ Fig. 14c, ME-MQ
Flame or induction hardened steels, Surface hardness: 520-620 HV10	94.3·HV10 + 120381	36.3·HV10 + 84122	Fig. 10, MQ Fig. 12, MQ
Alloyed through hardening steels, Surface hardness: 195-360 HV10	191.5·HV10 + 53954	113.1 HV10 + 58015	Fig. 5, MQ Fig. 7, MQ
Through hardened carbon steels, Surface hardness: 135-210 HV10	152.3·HV10 + 48588	72.5·HV10 + 46412	Fig. 5, Carbon steel, MQ Fig. 7, Carbon steel, MQ
Alloyed cast steels, Surface hardness: 198-358 HV10	188.6 HV10 + 42786	98.6 HV10 + 47137	Fig. 6, MQ-ML Fig. 8, MQ-ML
Cast carbon steels, Surface hardness: 135-210 HV10	126.2·HV10 + 42061	72.5·HV10 + 32633	Fig. 6, Carbon steel, MQ-ML Fig. 8, Carbon steel, MQ-ML

Notes

HV10: Vickers hardness at load $F = 98.10$ N, see ISO 6336-5

- 1 Core hardness ≥ 25 HRC, Jominy hardenability at $J = 12$ mm \geq HRC 28 and Surface hardness: 640-780 HV10
- 2 Core hardness ≥ 30 HRC, Surface hardness: 660-780 HV10
- 3 Core hardness ≥ 25 HRC, Jominy hardenability at $J = 12$ mm $<$ HRC 28 and Surface hardness: 640-780 HV10

TABLE 4
Determination of Life Factor for Contact Stress, Z_N

(Ref. 4-3-1A1/21.21)

<i>Material</i>	<i>Number of load cycles</i>	<i>Life factor Z_N</i>
St, V, GGG (perl., bain.), GTS (perl.), Eh, IF; Only when a certain degree of pitting is permissible	$N_L \leq 6 \times 10^5$, static	1.6
	$N_L = 10^7$	1.3
	$N_L = 10^9$	1.0
	$N_L = 10^{10}$ Optimum lubrication, material, manufacturing, and experience	0.85 1.0
St, V, GGG (perl., bain.), GTS (perl.), Eh, IF	$N_L \leq 10^5$, static	1.6
	$N_L = 5 \times 10^7$	1.0
	$N_L = 10^{10}$	0.85
	Optimum lubrication, material, manufacturing, and experience	1.0
GG, GGG (ferr.), NT (nitr.), NV (nitr.)	$N_L \leq 10^5$, static	1.3
	$N_L = 2 \times 10^6$	1.0
	$N_L = 10^{10}$	0.85
	Optimum lubrication, material, manufacturing, and experience	1.0
NV (nitrocar.)	$N_L \leq 10^5$, static	1.1
	$N_L = 2 \times 10^6$	1.0
	$N_L = 10^{10}$ Optimum lubrication, material, manufacturing, and experience	0.85 1.0
St: V: GG: GGG (perl., bain., ferr.): GTS (perl.): Eh: IF: NT (nitr.): NV (nitr.): NV (nitrocar.):	steel ($U < 800 \text{ N/mm}^2$, 82 kgf/mm^2 , $1.16 \times 10^5 \text{ psi}$) through-hardening steel, through-hardened ($U \geq 800 \text{ N/mm}^2$) gray cast iron nodular cast iron (perlitic, bainitic, ferritic structure) black malleable cast iron (perlitic structure) case-hardening steel, case hardening steel and GGG, flame or induction hardened nitriding steel, nitrided through-hardening and case-hardening steel, nitrided through-hardening and case-hardening steel, nitrocarburized	

TABLE 5
Determination of Life Factor for Tooth Root Bending Stress, Y_N

(Ref. 4-3-1A1/23.21)

<i>Material</i>	<i>Number of load cycles</i>	<i>Life factor Y_N</i>
V, GGG (perl., bain.), GTS (perl.)	$N_L \leq 10^4$, static	2.5
	$N_L = 3 \times 10^6$	1.0
	$N_L = 10^{10}$	0.85
	Optimum lubrication, material, manufacturing, and experience	1.0
Eh, IF (root)	$N_L \leq 10^3$, static	2.5
	$N_L = 3 \times 10^6$	1.0
	$N_L = 10^{10}$	0.85
	Optimum lubrication, material, manufacturing, and experience	1.0
St, NT, NV (nitr.), GG, GGG (ferr.)	$N_L \leq 10^3$, static	1.6
	$N_L = 3 \times 10^6$	1.0
	$N_L = 10^{10}$	0.85
	Optimum lubrication, material, manufacturing, and experience	1.0
NV (nitrocar.)	$N_L \leq 10^3$, static	1.0
	$N_L = 3 \times 10^6$	1.0
	$N_L = 10^{10}$	0.85
	Optimum lubrication, material, manufacturing, and experience	1.0

Notes:

1) Abbreviations of materials are as explained in 4-3-1A1/Table 4 and 4-3-1A1/21.21 of this Appendix.

2) $N_L = n \cdot 60 \cdot HPD \cdot DPY \cdot YRS$

n = rotational speed, rpm.

HPD = operation hours per day

DPY = days per year

YRS = years (normal life of vessel = 25 years)

TABLE 6
Constant K' for the Calculation of the Pinion Offset Factor γ

Factor K'		Figure	Arrangement
with stiffening ⁽¹⁾	without stiffening ⁽¹⁾		
0.48	0.8	a)	 <p style="text-align: right;">with $s/\ell < 0.3$</p>
-0.48	-0.8	b)	 <p style="text-align: right;">with $s/\ell < 0.3$</p>
1.33	1.33	c)	 <p style="text-align: right;">with $s/\ell < 0.3$</p>
-0.36	-0.6	d)	 <p style="text-align: right;">with $s/\ell < 0.3$</p>
-0.6	-1.0	e)	 <p style="text-align: right;">with $s/\ell < 0.3$</p>
<p>1. When $d_1/d_{sh} \geq 1.15$, stiffening is assumed; when $d_1/d_{sh} < 1.15$, there is no stiffening. Furthermore, scarcely any or no stiffening at all is to be expected when a pinion slides on a shaft and feather key or a similar fitting, nor when normally shrink fitted.</p> <p>T^* is the input or output torqued end, not dependent on direction of rotation.</p> <p>Dashed line indicates the less deformed helix of a double helical gear.</p> <p>Determine t_{sh} from the diameter in the gaps of double helical gearing mounted centrally between bearings.</p>			

FIGURE 1
Tooth in Normal Section



External cylindrical gears

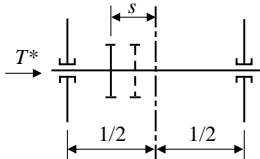
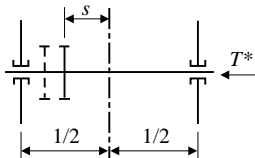
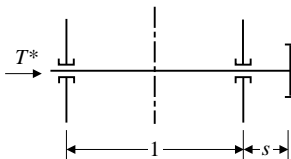
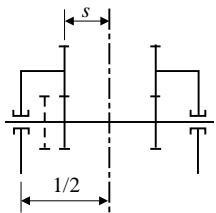
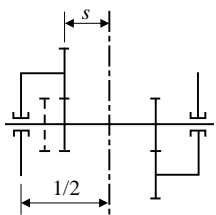
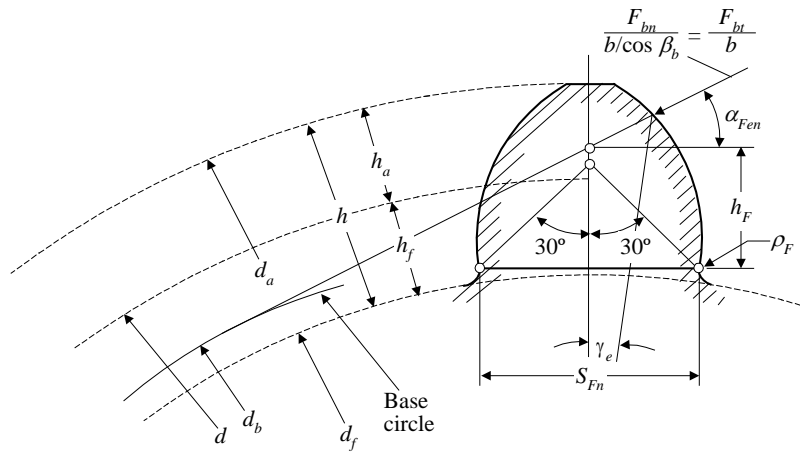
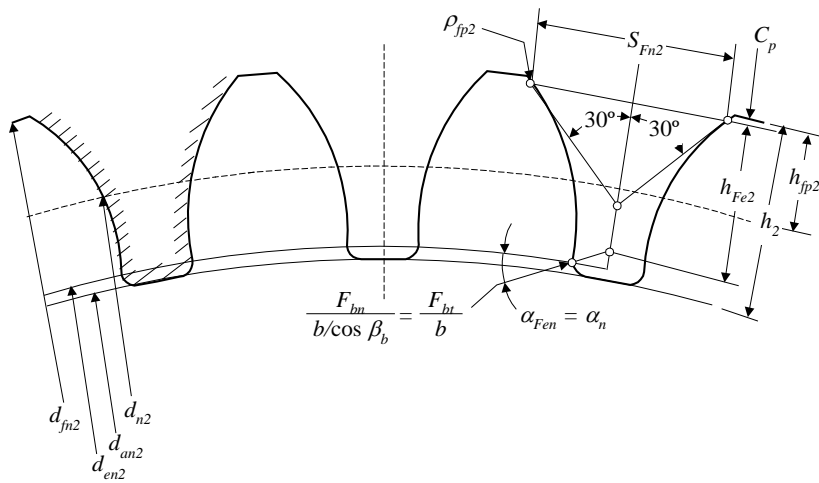

Internal cylindrical gears

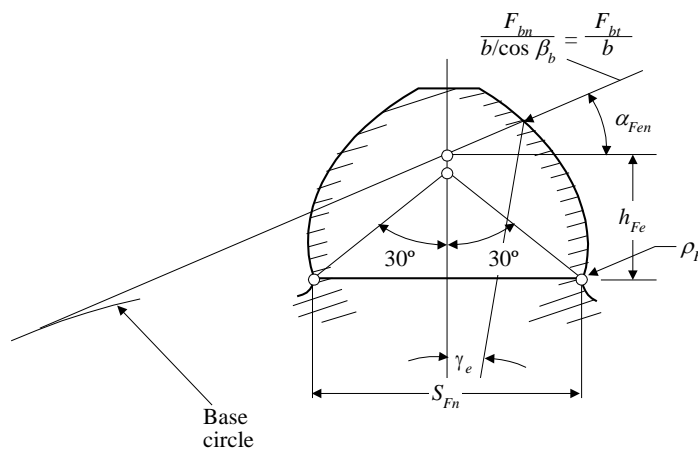

Bevel gears

FIGURE 2
Dimensions and Basic Rack Profile of the Tooth (Finished Profile)

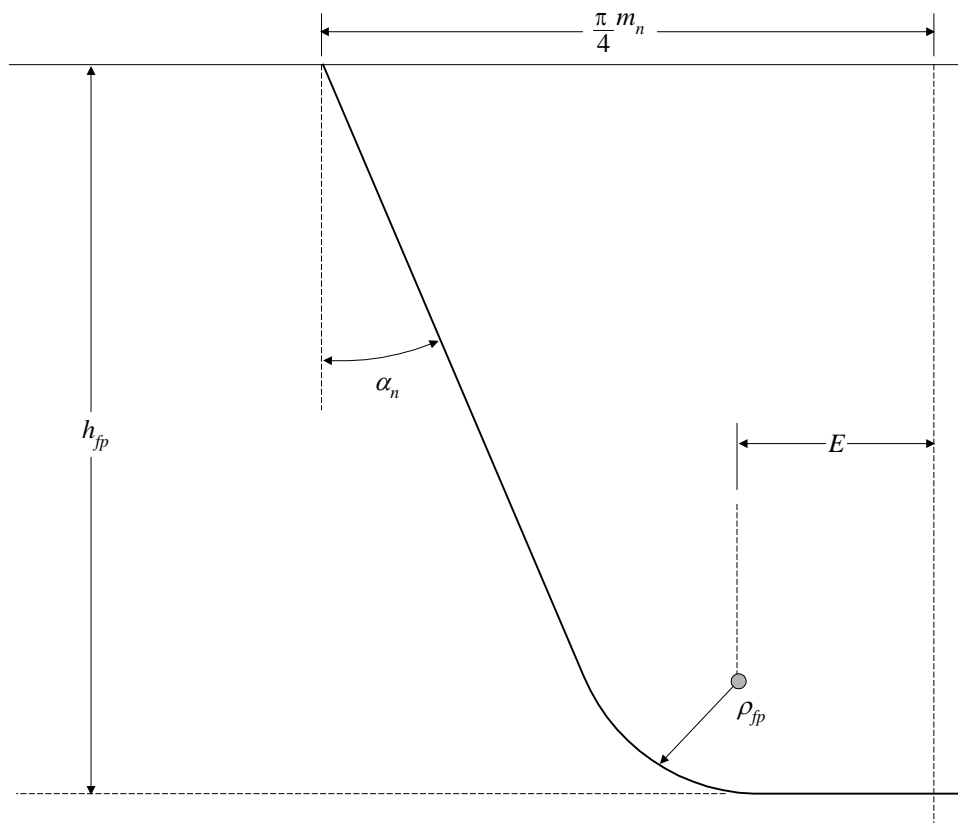

Without undercut

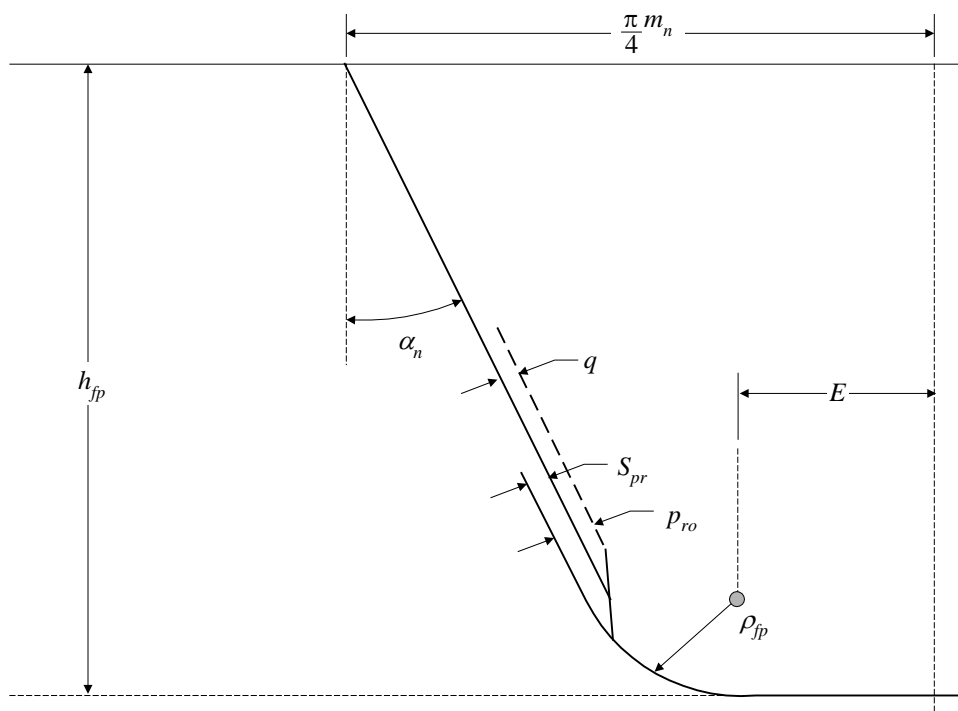

With undercut

FIGURE 3
Wheel Blank Factor C_R , Mean Values for Mating Gears
of Similar or Stiffer Wheel Blank Design

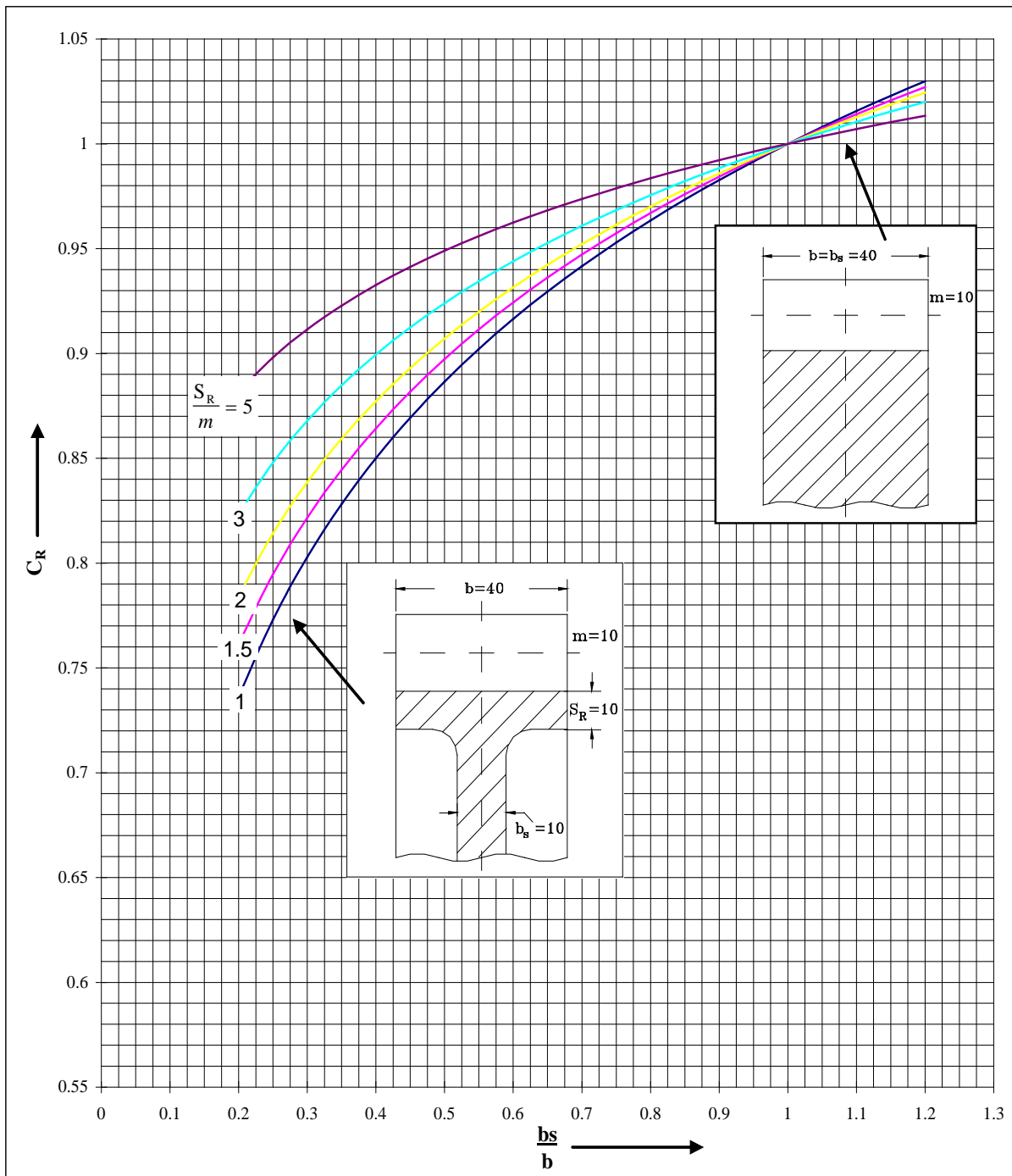

FIGURE 4
Bevel Gear Conversion to Equivalent Cylindrical Gear

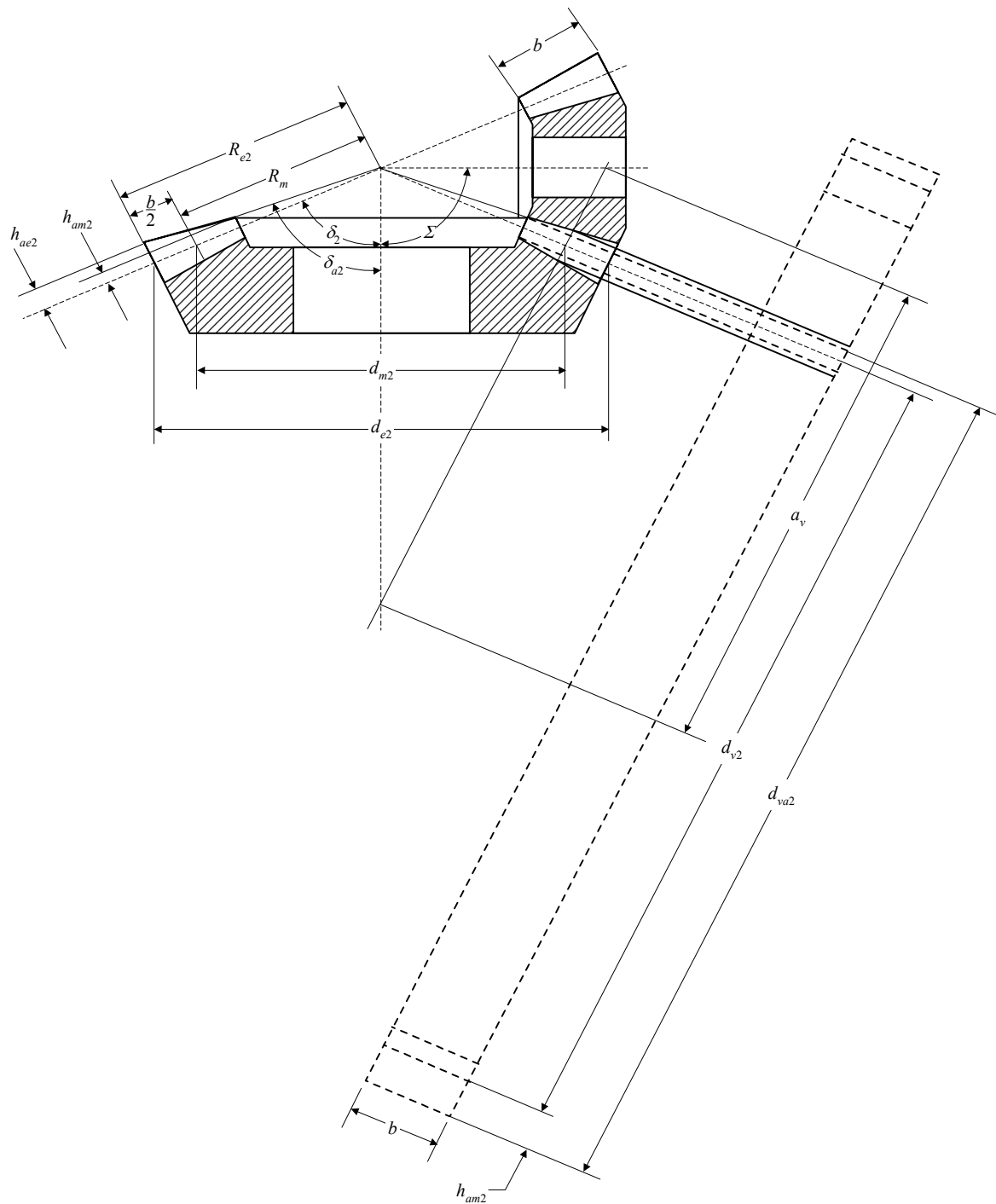
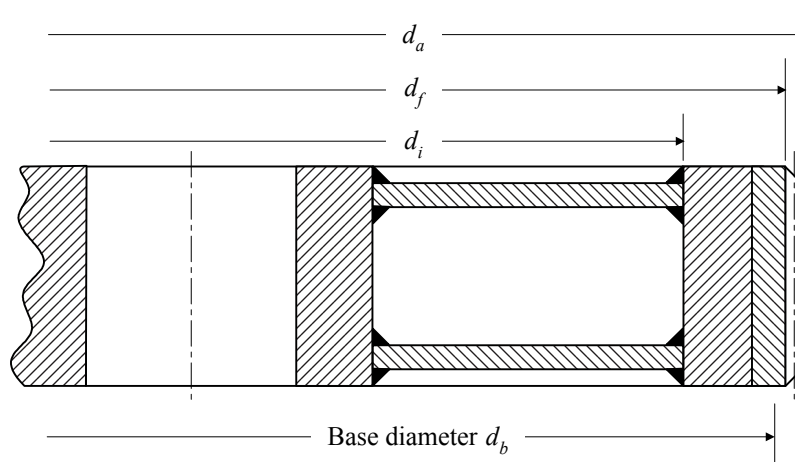

FIGURE 5
Definitions of the Various Diameters



PART

4

CHAPTER 3 Propulsion and Maneuvering Machinery

SECTION 1 Appendix 2 – Guidance for Spare Parts

1 General

While spare parts are not required for purposes of classification, the spare parts listed below are provided as a guidance for vessels intended for unrestricted service. The maintenance of spare parts aboard each vessel is the responsibility of the owner.

3 Spare Parts for Gears

- a) Sufficient packing rings with springs to repack one gland of each kind and size.
- b) One (1) set of thrust pads or rings, also springs where fitted, for each size.
- c) Bearing bushings sufficient to replace all of the bushings on every pinion, and gear for main propulsion; spare bearing bushings sufficient to replace all of the bushings on each non-identical pinion and gear having sleeve-type bearings or complete assemblies consisting of outer and inner races and cages complete with rollers or balls where these types of bearings are used.
- d) One (1) set of bearing shoes for one face, for one single-collar type main thrust bearing where fitted. Where the ahead and astern pads differ, pads for both faces are to be provided.
- e) One (1) set of strainer baskets or inserts for oil filters of special design of each type and size.
- f) Necessary special tools.

PART

4

CHAPTER 3 Propulsion and Maneuvering Machinery

SECTION 1 Appendix 3 – Gear Parameters

For purposes of submitting gear design for review, the following data and parameters may be used as a guide.

Gear manufacturer Year of build
Shipyard Hull number
Ship's name Shipowner

GENERAL DATA ⁽¹⁾

Gearing type
..... (non reversible, single reduction, double reduction, epicyclic, etc.)
Total gear ratio
Manufacturer and type of the main propulsion plant (or of the auxiliary machinery)
.....
Power ⁽²⁾ kW, (PS, hp) Rotational speed ⁽²⁾ RPM
Maximum input torque for continuous service N-m, (kgf-m, lbf-ft)
Maximum input rotational speed for continuous service RPM
Type of coupling: (stiff coupling, hydraulic or equivalent coupling, high-elasticity coupling, other couplings, quill shafts, etc.)
Specified grade of lubricating oil
Expected oil temperature when operating at the classification power (mean values of temperature at inlet and outlet of reverse and/or reduction gearing)
Value of nominal kinematic viscosity, ν , at 40°C or 50°C of oil temperature (mm²/s)

CHARACTERISTIC ELEMENTS OF PINIONS AND WHEELS Gear drive designation		First gear Drive	Second gear drive	Third gear drive	Fourth gear drive
Transmitted rated power, input in the gear drive – kW (mhp, hp) ⁽³⁾	P				
Rotational speed, input in the gear drive (RPM) ⁽²⁾	n				
Nominal transverse tangential load at reference cylinder – N, (kgf, lbf) ⁽⁴⁾	F_t				
Number of teeth of pinion	z_1				
Number of teeth of wheel	z_2				
Gear ratio	u				
Center distance – mm (in.)	a				
Facewidth of pinion – mm (in.)	b_1				
Facewidth of wheel – mm (in.)	b_2				
Common facewidth – mm (in.)	b				
Overall facewidth, including the gap for double helical gears – mm (in.)	B				

- 1 The manufacturer can supply values, if available, supported by documents for stress numbers σ_{Hlim} and σ_{FE} involved in the formulas for gear strength with respect to the contact stress and with respect to the tooth root bending stress. See 4-3-1A1/21 and 4-3-1A1/23.
- 2 Maximum continuous performance of the machinery for which classification is requested.
- 3 It is intended the power mentioned under note (2) or fraction of it in case of divided power.
- 4 The nominal transverse tangential load is calculated on the basis of the above mentioned maximum continuous performance or on the basis of astern power when it gives a higher torque. In the case of navigation in ice, the nominal transverse tangential load is to be increased as required by 4-3-1A1/9.

CHARACTERISTIC ELEMENTS OF PINIONS AND WHEELS Gear drive designation		First gear drive	Second gear Drive	Third gear drive	Fourth gear drive
Is the wheel an external or an internal teeth gear?	-				
Number of pinions	-				
Number of wheels	-				
Is the wheel an external or an internal teeth gear	-				
Is the pinion an intermediate gear?	-				
Is the wheel an intermediate gear?	-				
Is the carrier stationary or revolving (star or planet-carrier)? ⁽⁵⁾	-				
Reference diameter of pinion – mm (in.)	d_1				
Reference diameter of wheel – mm (in.)	d_2				
Working pitch diameter of pinion – mm (in.)	d_{w1}				
Working pitch diameter of wheel – mm (in.)	d_{w2}				
Tip diameter of pinion – mm (in.)	d_{a1}				
Tip diameter of wheel – mm (in.)	d_{a2}				
Base diameter of pinion – mm (in.)	d_{b1}				
Base diameter of wheel – mm (in.)	d_{b2}				
Tooth depth of pinion – mm (in.) ⁽⁶⁾	h_1				
Tooth depth of wheel – mm (in.) ⁽⁶⁾	h_2				
Addendum of pinion – mm (in.)	h_{a1}				
Addendum of wheel – mm (in.)	h_{a2}				
Addendum of tool referred to normal module for pinion	h_{a01}				
Addendum of tool referred to normal module for wheel	h_{a02}				
Dedendum of pinion – mm (in.)	h_{f1}				
Dedendum of wheel – mm (in.)	h_{f2}				
Dedendum of basic rack [referred to $m_n (=h_{a01})$] for pinion	h_{fp1}				
Dedendum of basic rack [referred to $m_n (=h_{a02})$] for wheel	h_{fp2}				
Bending moment arm of tooth – mm (in.) ⁽⁷⁾	h_F				
Bending moment arm of tooth – mm (in.) ⁽⁸⁾	h_{F2}				
Bending moment arm of tooth – mm (in.) ⁽⁹⁾	h_{Fa}				
Width of tooth at tooth-root normal chord – mm (in.) ^(7, 9)	S_{Fn}				
Width of tooth at tooth-root normal chord – mm (in.) ⁽⁸⁾	S_{Fn2}				
Angle of application of load at the highest point of single tooth contact (degrees)	α_{Fen}				
Pressure angle at the highest point of single tooth contact (degrees)	α_{en}				

5 Only for epicyclic gears.

6 Measured from the tip circle (or circle passing through the point of beginning of the fillet at the tooth tip) to the beginning of the root fillet.

7 Only for external gears.

8 Only for internal gears.

9 Only for bevel gears.

CHARACTERISTIC ELEMENTS OF PINIONS AND WHEELS Gear drive designation		First gear drive	Second gear drive	Third gear Drive	Fourth gear drive
Normal module – mm (in.)	m_n				
Outer normal module – mm (in.)	m_{na}				
Transverse module	m_t				
Addendum modification coefficient of pinion	x_1				
Addendum modification coefficient of wheel	x_2				
Addendum modification coefficient refers to the midsection ⁽⁹⁾	x_{mn}				
Tooth thickness modification coefficient (midface) ⁽⁹⁾	x_{sm}				
Addendum of tool – mm (in.)	h_{a0}				
Protuberance of tool – mm (in.)	P_{r0}				
Machining allowances – mm (in.)	q				
Tip radius of tool – mm (in.)	ρ_{a0}				
Profile form deviation – mm (in.)	f_{fa}				
Transverse base pitch deviation – mm (in.)	f_{pb}				
Root fillet radius at the critical section – mm (in.)	ρ_F				
Root radius of basic rack [referred to $m_n (= \rho_{a0})$] – mm (in.)	ρ_p				
Radius of curvature at pitch surface – mm (in.)	ρ_c				
Normal pressure angle at reference cylinder (degrees)	α_n				
Transverse pressure angle at reference cylinder (degrees)	α_t				
Transverse pressure angle at working pitch cylinder (degrees)	α_{tw}				
Helix angle at reference cylinder (degrees)	β				
Helix angle at base cylinder (degrees)	β_b				
Transverse contact ratio	ϵ_α				
Overlap ratio	ϵ_β				
Total contact ratio	ϵ_γ				
Angle of application of load at the highest point of single tooth contact (degrees) ⁽⁹⁾	α_{Fan}				
Reference cone angle of pinion (degrees) ⁽⁹⁾	δ_1				
Reference cone angle of wheel (degrees) ⁽⁹⁾	δ_2				
Shaft angle (degrees) ⁽⁹⁾	Σ				
Tip angle of pinion (degrees) ⁽⁹⁾	$\delta_{\alpha 1}$				
Tip angle of wheel (degrees) ⁽⁹⁾	$\delta_{\alpha 2}$				
Helix angle at reference cylinder (degrees) ⁽⁹⁾	β_m				
Cone distance pinion. wheel – mm (in.) ⁽⁹⁾	R				
Middle cone distance – mm (in.) ⁽⁹⁾	R_m				

9 Only for bevel gears.

MATERIALS

First gear drive

Pinion: Material grade or specification
 Complete chemical analysis.....

 Minimum ultimate tensile strength ⁽¹⁰⁾ N/mm², (kgf/mm², lbf/in²)
 Minimum yield strength ⁽¹⁰⁾ N/mm², (kgf/mm², lbf/in²)
 Elongation (A₅) % Hardness (HB, HV10 or HRC).....
 Heat treatment
 Description of teeth surface-hardening

 Specified surface hardness (HB, HV10 or HRC).....
 Depth of hardened layer versus hardness values (if possible in diagram)

 Finishing method of tooth flanks (hobbed, shaved, lapped, ground or shot-peened teeth).....

 Specified surface roughness R_Z or R_a relevant to tooth flank and root fillet
 Amount of tooth flank corrections (tip-relief, end-relief, crowning and helix correction) if any
 Specified grade of accuracy (according to ISO 1328)

 Amount of shrinkage with tolerances specifying the procedure foreseen for shrinking and measures
 proposed to ensure the securing of rims. ⁽¹¹⁾

Wheel: Material grade or specification
 Complete chemical analysis.....

 Minimum ultimate tensile strength ⁽¹⁰⁾ N/mm², (kgf/mm², lbf/in²)
 Minimum yield strength ⁽¹⁰⁾ N/mm², (kgf/mm², lbf/in²)
 Elongation (A₅) % Hardness (HB, HV10 or HRC).....
 Heat treatment
 Description of teeth surface-hardening

 Specified surface hardness (HB, HV10 or HRC).....
 Depth of hardened layer versus hardness values (if possible in diagram)

 Finishing method of tooth flanks (hobbed, shaved, lapped, ground or shot-peened teeth).....

 Specified surface roughness R_Z or R_a relevant to tooth flank and root fillet
 Amount of tooth flank corrections (tip-relief, end-relief, crowning and helix correction) if any

 Specified grade of accuracy (according to ISO 1328)

 Amount of shrinkage with tolerances specifying the procedure foreseen for shrinking and measures
 proposed to ensure the securing of rims. ⁽¹¹⁾

- 10 Relevant to core of material
- 11 In case of shrink-fitted pinions, wheel rims or hubs

Second gear drive

Pinion: Material grade or specification
 Complete chemical analysis.....

 Minimum ultimate tensile strength ⁽¹⁰⁾ N/mm², (kgf/mm², lbf/in²)
 Minimum yield strength ⁽¹⁰⁾ N/mm², (kgf/mm², lbf/in²)
 Elongation (A₅) % Hardness (HB, HV10 or HRC)
 Heat treatment.....
 Description of teeth surface-hardening

 Specified surface hardness (HB, HV10 or HRC).....
 Depth of hardened layer versus hardness values (if possible in diagram)

 Finishing method of tooth flanks (hobbed, shaved, lapped, ground or shot-peened teeth).....

 Specified surface roughness R_Z or R_a relevant to tooth flank and root fillet
 Amount of tooth flank corrections (tip-relief, end-relief, crowning and helix correction) if any.....

 Specified grade of accuracy (according to ISO 1328)

 Amount of shrinkage with tolerances specifying the procedure foreseen for shrinking and measures proposed to ensure the securing of rims. ⁽¹¹⁾

Wheel: Material grade or specification
 Complete chemical analysis.....

 Minimum ultimate tensile strength ⁽¹⁰⁾ N/mm², (kgf/mm², lbf/in²)
 Minimum yield strength ⁽¹⁰⁾ N/mm², (kgf/mm², lbf/in²)
 Elongation (A₅) %; Hardness (HB, HV10 or HRC)
 Heat treatment.....
 Description of teeth surface-hardening

 Specified surface hardness (HB, HV10 or HRC).....
 Depth of hardened layer versus hardness values (if possible in diagram)

 Finishing method of tooth flanks (hobbed, shaved, lapped, ground or shot-peened teeth).....

 Specified surface roughness R_Z or R_a relevant to tooth flank and root fillet
 Amount of tooth flank corrections (tip-relief, end-relief, crowning and helix correction) if any.....

 Specified grade of accuracy (according to ISO 1328)

 Amount of shrinkage with tolerances specifying the procedure foreseen for shrinking and measures proposed to ensure the securing of rims. ⁽¹¹⁾

10 Relevant to core of material
 11 In case of shrink-fitted pinions, wheel rims or hubs

Third gear drive

Pinion: Material grade or specification
 Complete chemical analysis.....

 Minimum ultimate tensile strength ⁽¹⁰⁾ N/mm², (kgf/mm², lbf/in²)
 Minimum yield strength ⁽¹⁰⁾ N/mm², (kgf/mm², lbf/in²)
 Elongation (A₅) %; Hardness (HB, HV10 or HRC)
 Heat treatment.....
 Description of teeth surface-hardening

 Specified surface hardness (HB, HV10 or HRC).....
 Depth of hardened layer versus hardness values (if possible in diagram)

 Finishing method of tooth flanks (hobbed, shaved, lapped, ground or shot-peened teeth).....

 Specified surface roughness R_Z or R_a relevant to tooth flank and root fillet
 Amount of tooth flank corrections (tip-relief, end-relief, crowning and helix correction) if any

 Specified grade of accuracy (according to ISO 1328)

 Amount of shrinkage with tolerances specifying the procedure foreseen for shrinking and measures proposed to ensure the securing of rims. ⁽¹¹⁾

Wheel: Material grade or specification
 Complete chemical analysis.....

 Minimum ultimate tensile strength ⁽¹⁰⁾ N/mm², (kgf/mm², lbf/in²)
 Minimum yield strength ⁽¹⁰⁾ N/mm², (kgf/mm², lbf/in²)
 Elongation (A₅) %; Hardness (HB, HV10 or HRC)
 Heat treatment.....
 Description of teeth surface-hardening

 Specified surface hardness (HB, HV10 or HRC).....
 Depth of hardened layer versus hardness values (if possible in diagram)

 Finishing method of tooth flanks (hobbed, shaved, lapped, ground or shot-peened teeth).....

 Specified surface roughness R_Z or R_a relevant to tooth flank and root fillet
 Amount of tooth flank corrections (tip-relief, end-relief, crowning and helix correction) if any

 Specified grade of accuracy (according to ISO 1328)

 Amount of shrinkage with tolerances specifying the procedure foreseen for shrinking and measures proposed to ensure the securing of rims. ⁽¹¹⁾

10 Relevant to core of material
 11 In case of shrink-fitted pinions, wheel rims or hubs

Fourth gear drive

Pinion: Material grade or specification	
Complete chemical analysis.....	
.....	
.....	
Minimum ultimate tensile strength ⁽¹⁰⁾	N/mm ² , (kgf/mm ² , lbf/in ²)
Minimum yield strength ⁽¹⁰⁾	N/mm ² , (kgf/mm ² , lbf/in ²)
Elongation (A ₅)	%; Hardness (HB, HV10 or HRC)
Heat treatment.....	
Description of teeth surface-hardening	
.....	
.....	
Specified surface hardness (HB, HV10 or HRC).....	
Depth of hardened layer versus hardness values (if possible in diagram)	
.....	
.....	
Finishing method of tooth flanks (hobbed, shaved, lapped, ground or shot-peened teeth).....	
.....	
.....	
Specified surface roughness R _Z or R _a relevant to tooth flank and root fillet	
Amount of tooth flank corrections (tip-relief, end-relief, crowning and helix correction) if any	
.....	
Specified grade of accuracy (according to ISO 1328)	
.....	
Amount of shrinkage with tolerances specifying the procedure foreseen for shrinking and measures proposed to ensure the securing of rims. ⁽¹¹⁾	
Wheel: Material grade or specification	
Complete chemical analysis.....	
.....	
.....	
Minimum ultimate tensile strength ⁽¹⁰⁾	N/mm ² , (kgf/mm ² , lbf/in ²)
Minimum yield strength ⁽¹⁰⁾	N/mm ² , (kgf/mm ² , lbf/in ²)
Elongation (A ₅)	%; Hardness (HB, HV10 or HRC)
Heat treatment.....	
Description of teeth surface-hardening	
.....	
.....	
Specified surface hardness (HB, HV10 or HRC).....	
Depth of hardened layer versus hardness values (if possible in diagram)	
.....	
.....	
Finishing method of tooth flanks (hobbed, shaved, lapped, ground or shot-peened teeth).....	
.....	
.....	
Specified surface roughness R _Z or R _a relevant to tooth flank and root fillet	
Amount of tooth flank corrections (tip-relief, end-relief, crowning and helix correction) if any	
.....	
Specified grade of accuracy (according to ISO 1328)	
.....	
Amount of shrinkage with tolerances specifying the procedure foreseen for shrinking and measures proposed to ensure the securing of rims. ⁽¹¹⁾	

10 Relevant to core of material
 11 In case of shrink-fitted pinions, wheel rims or hubs

PART

4

CHAPTER 3 Propulsion and Maneuvering Machinery

SECTION 2 Propulsion Shafting

1 General

1.1 Application

This section applies to shafts, couplings, clutches and other power transmitting components for propulsion purposes.

Shafts and associated components used for transmission of power, essential for the propulsion of the vessel, are to be so designed and constructed to withstand the maximum working stresses to which they may be subjected in all service conditions.

Consideration may be given to designs based on engineering analyses, including fatigue considerations, as an alternative to the provisions of this section. Alternative calculation methods are to take into account design criteria for continuous and transient operating loads (dimensioning for fatigue strength) and for peak operating loads (dimensioning for yield strength).

Note: Shafts complying with this section satisfy the following:

- 1 Low cycle fatigue criterion (typically $< 10^4$), (i.e., the primary cycles represented by zero to full load and back to zero, including reversing torque if applicable). This is addressed by the formula in 4-3-2/5.1.
- 2 High cycle fatigue criterion (typically $\gg 10^7$), (i.e., torsional vibration stresses permitted for continuous operation as well as reverse bending stresses). The limits for torsional vibration stresses are given in 4-3-2/7.5.1. The influence of reverse bending stresses is addressed by the safety margins inherent in the formula in 4-3-2/5.1.
- 3 The accumulated fatigue due to torsional vibration when passing through a barred speed range or any other transient condition with associated stresses beyond those permitted for continuous operation is addressed by the criterion for transient stresses in 4-3-2/7.5.1.

Additional requirements for shafting intended for vessels strengthened for navigation in ice are provided in Part 6.

1.3 Definitions

For the purposes of using shaft diameter formulas in this section, the following definitions apply.

1.3.1 Tail Shaft

Tail Shaft is the part of the propulsion shaft aft of the forward end of the propeller end bearing.

1.3.2 Stern Tube Shaft

Stern Tube Shaft or *Tube Shaft* is the part of the propulsion shaft passing through the stern tube from the forward end of the propeller end bearing to the in-board shaft seal.

1.3.3 Line Shaft

Line Shaft is the part of the propulsion shaft in-board of the vessel.

1.3.4 Thrust Shaft

Thrust Shaft is that part of the propulsion shaft which transmits thrust to the thrust bearing.

1.3.5 Oil Distribution Shaft

Oil Distribution Shaft is a hollow propulsion shaft where the bore and radial holes are used for distribution of hydraulic oil in controllable pitch propeller installations.

1.5 Plans and Particulars to be Submitted

The following plans and particulars are to be submitted for review:

1.5.1 For Propulsion Shafting

Shafting arrangement

Rated power of main engine and shaft rpm

Thrust, line, tube and tail shafts, as applicable

Couplings – integral, demountable, keyed, or shrink-fit, coupling bolts* and keys

Engineering analyses and fitting instructions for shrink-fit couplings

Shaft bearings

Stern tube

Shaft seals

Shaft lubricating system

Power take-off to shaft generators, propulsion boosters, or similar equipment, rated 100 kW (135 hp) and over, as applicable

Materials

* *Note:* Specific details regarding the interference fit of the coupling bolts are to be submitted. In addition, calculations and detail design basis for the sizing of the fitted bolts are to be submitted if the sizing of the bolts as per 4-3-2/5.19.1 of the Rules is not based on as-built line shaft diameter “D”.

1.5.2 For Clutches

Construction details of torque transmitting components, housing along with their materials and dimensions.

Rated power and rpm

Engineering analyses

Clutch operating data

1.5.3 For Flexible Couplings

Construction details of torque transmitting components, housing, along with their dimensions and materials

Static and dynamic torsional stiffness and damping characteristics

Rated power, torque, and rpm.

Engineering analyses

Allowable vibratory torque for continuous and transient operation.

Allowable power loss (overheating)

Allowable misalignment for continuous operation

1.5.4 For Cardan Shafts

Dimensions of all torque transmitting components and their materials

Rated power of main engine and shaft rpm

Engineering analyses

Clutch operating data

1.5.5 Calculations

Propulsion shaft alignment calculations where propulsion shaft is sensitive to alignment (see 4-3-2/7.3).

Torsional vibration analyses

Axial and lateral (whirling) vibration calculations where there are barred speed ranges within engine operating speed range

3 Materials

3.1 General

Materials for propulsion shafts, couplings and coupling bolts, keys and clutches are to be of forged steel or rolled bars, as appropriate, in accordance with Sections 2-3-7 and 2-3-8 of the *ABS Rules for Materials and Welding (Part 2)* or other specifications as may be specially approved with a specific design. Where materials other than those specified in these Rules are proposed, full details of chemical composition, heat treatment and mechanical properties, as appropriate, are to be submitted for approval.

3.1.1 Ultimate Tensile Strength

In general, the minimum specified ultimate tensile strength of steel used for propulsion shafting is to be between 400 N/mm² (40.7 kgf/mm², 58,000 psi) and 800 N/mm² (81.5 kgf/mm², 116,000 psi). The upper limit can be extended up to 930 N/mm² (95.0 kgf/mm², 135,000 psi) for vessels below 90 m (295 ft) in length.

3.1.2 Elongation

Carbon steel with elongation ($L_0/d = 4$) of less than 16% or ($L_0/d = 5$) of less than 15% is not to be used for any shafting component, with the exception that material for non-fitted alloy steel coupling bolts manufactured to a recognized standard may have elongation ($L_0/d = 4$) of not less than 10% or ($L_0/d = 5$) of not less than 9%.

Alloy steels with elongation less than ($L_0/d = 4$) 16% or ($L_0/d = 5$) 15% may be applied subject to approval.

3.1.3 Alternative Test Requirements

Materials for shafting, couplings and coupling bolts transmitting 373 kW (500 HP) or less will be accepted based on the manufacturer's certified mill tests and hardness check witnessed by the Surveyor. Bolts manufactured to a recognized standard and used as coupling bolts will not require material testing.

3.3 Weldability

Where repair by welding or where cladding by welding is contemplated, steel used for propulsion shafts is to have carbon content in accordance with 2-3-7/1.1.2. For approval of welding of the shaft, refer to Appendix 7-A-11 "Repair and Cladding of Shafts" of the *ABS Rules for Survey After Construction (Part 7)*.

3.5 Shaft Liners

Liners may be of bronze, stainless steel or other approved alloys and are to be free from porosity and other defects. Continuous liners are to be in one piece or, if made of two or more lengths, the joining of the separate pieces is to be done by an approved method of welding through not less than two-thirds the thickness of the liner or by an approved rubber seal arrangement.

3.7 Material Tests

3.7.1 General

Materials for all torque-transmitting parts, including shafts, clutches, couplings, coupling bolts and keys are to be tested in the presence of the Surveyor. The materials are to meet the specifications of 2-3-7/5, 2-3-7/7 and 2-3-8/1 or other specifications approved in connection with the design.

3.7.2 Alternative Test Requirements

3.7.2(a) 375 kW (500 hp) or less. Materials for parts transmitting 375 kW (500 hp) or less may be accepted by the Surveyor based on verification of manufacturer's certification and witnessed hardness check.

3.7.2(b) Coupling bolts. Coupling bolts manufactured and marked to a recognized standard will not require material testing.

3.7.3 Inspections and Nondestructive Tests

Shafting and couplings are to be surface examined by the Surveyor.

Forgings for tail shafts 455 mm (18 in.) and over in finished diameter are to be ultrasonically examined in accordance with 2-3-7/1.13.2. Tail shafts in the finished machine condition are to be subjected to magnetic particle, dye penetrant or other nondestructive examinations. They are to be free of linear discontinuities greater than 3.2 mm (1/8 in.), except that in the following locations the shafts are to be free of all linear discontinuities:

3.7.3(a) Tapered tail shafts: the forward one-third length of the taper, including the forward end of any keyway and an equal length of the parallel part of the shaft immediately forward of the taper.

3.7.3(b) Flanged tail shafts: the flange fillet area.

5 Design and Construction

5.1 Shaft Diameters

The minimum diameter of propulsion shafting is to be determined by the following equation:

$$D = 100K \cdot \sqrt[3]{\frac{H}{R} \left(\frac{c_1}{U + c_2} \right)}$$

where

D = greater of the required solid shaft diameter as required by 4-3-2/5 or 4-3-2/7.5 through 4-3-2/7.9 (reflective of static and dynamic stresses), except hollow shaft; mm (in.)

d_i = diameter of internal bore; mm (in.)

H = power at rated speed; kW (PS, hp) (1 PS = 735 W; 1 hp = 746 W)

K = shaft design factor, see 4-3-2/Table 1 or 4-3-2/Table 2

R = rated speed rpm

U = minimum specified ultimate tensile strength of shaft material (regardless of the actual minimum specified tensile strength of the material, the value of U used in these calculations is not to exceed that indicated in 4-3-2/Table 3; N/mm² (kgf/mm², psi). Where materials with greater specified or actual tensile strengths than the limitations given above are used, reduced shaft dimensions or higher permissible vibration stresses are not acceptable when derived from the formulae in this section unless the ABS verifies that the materials exhibit similar fatigue life as conventional steels (see Appendix 4-3-2A1)

e = slot width mm (in.)

ℓ = slot length mm (in.)

c_1 and c_2 are given below:

c_1	=	560 (41.95, 3.695)	for vessels 45.7 m (150 ft) in length and over
	=	472.5 (35.4, 3.12)	for vessels 20 m (65 ft) and over, but below 45.7 m (150 ft), where the material of the shaft is Grade 2 and the shaft is protected
c_1	=	540 (40.3, 3.55)	for vessels 20 m (65 ft) and over, but below 45.7 m (150 ft), for all other materials and unprotected Grade 2 shaft material
	=	416.4 (31.22, 2.75)	for vessels below 20 m (65 ft)
c_2	=	160 (16.3, 23180)	

TABLE 1
Shaft Design Factors K and C_K for Line Shafts and Thrust Shafts

Factor	Propulsion drives	Design Features ⁽¹⁾							
		Integral flange	Shrink fit coupling	Keyways ⁽²⁾	Radial holes, transverse holes ⁽³⁾	Longitudinal slots ⁽⁴⁾	On both sides of thrust collars	In way of axial bearings used as thrust bearings	Straight sections
K	Type A	0.95	0.95	1.045	1.045	1.14	1.045	1.045	0.95
	Type B	1.0	1.0	1.1	1.1	1.2	1.1	1.1	1.0
C_K		1.0	1.0	0.6	0.5	0.3	0.85	0.85	1.0

Type A: Turbine drives; electric drives; diesel drive through slip couplings (electric or hydraulic).

Type B: All other diesel drives.

Notes

- Geometric features other than those listed will be specially considered.
- After a length of not less than $0.2D$ from the end of the keyway, the shaft diameter may be reduced to the diameter calculated for straight sections.
Fillet radii in the transverse section of the keyway are not to be less than $0.0125D$.
- Diameter of bore not more than $0.3D$.
- Subject to limitations as slot length (ℓ)/outside diameter < 0.8 and inner diameter (d_i)/outside diameter < 0.7 and slot width (e)/outside diameter > 0.15 . The end rounding of the slot is not to be less than $e/2$. An edge rounding should preferably be avoided as this increases the stress concentration slightly.
The k and c_K values are valid for 1, 2 and 3 slots, (i.e., with slots at 360 respectively 180, and respectively 120 degrees apart).
- $c_K = 0.3$ is an approximation within the limitations in Note 4. More accurate estimate of the stress concentration factor (scf) may be determined from Appendix 4-3-2A1 or by direct application of FE calculation. In which case:
 $c_K = 1.45/\text{scf}$

Note that the scf is defined as the ratio between the maximum local principal stress and $\sqrt{3}$ times the nominal torsional stress (determined for the bored shaft without slots)

FIGURE 1
Intersection between a Radial and an Eccentric Axial Bore

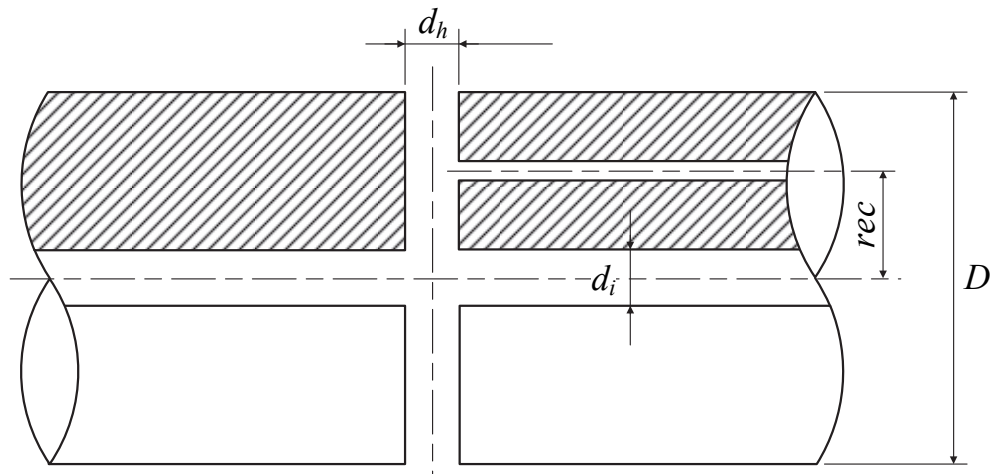

TABLE 2
Shaft Design Factors K and C_K for Tail Shafts and Stern Tube Shafts ⁽¹⁾

Factor	Propulsion drive	Stern tube configuration	Tail shafts: propeller attachment method ⁽²⁾			Stern tube shafts ^(7, 8)
			Keyed ⁽³⁾	Keyless attachment by shrink fit ⁽⁴⁾	Flanged ⁽⁵⁾	
K	All	Oil lubricated bearings	1.26	1.22	1.22	1.15
	All	Water lubricated bearings: continuous shaft liners or equivalent (see 4-3-2/5.17.6)	1.26	1.22	1.22	1.15
	All	Water lubricated bearings: non-continuous shaft liners ⁽⁶⁾	1.29	1.25	1.25	1.18
C_K			0.55	0.55	0.55	0.8

Notes

- 1 Tail shaft may be reduced to stern tube shaft diameter forward of the bearing supporting the propeller, and the stern tube shaft reduced to line shaft diameter inboard of the forward stern tube seal. The inboard end of tail shafts or tube shafts within the vessel, as applicable, is to be designed the same as line shafts, with shaft design factors in accordance with 4-3-2/Table 1.
- 2 Other attachments are subject to special consideration.
- 3 Fillet radii in the transverse section at the bottom of the keyway are not to be less than 0.0125D.
- 4 See also 4-3-2/5.11 and 4-3-3/5.15.2.
- 5 For flange fillet radii and flange thickness, see 4-3-2/5.19.3.
- 6 For Great Lakes Service, K factor corresponding to continuous liner configuration may be used.
- 7 K factor applies to shafting between the forward edge of the propeller-end bearing and the inboard stern tube seal.
- 8 Where keyed couplings are fitted on stern tube shaft, the shaft diameters are to be increased by 10% in way of the coupling. See Note 2 of 4-3-2/Table 1.

TABLE 3
Maximum Values of U to be Used in Shaft Calculations

	<i>SI units</i> <i>N/mm²</i>	<i>MKS units</i> <i>kgf/mm²</i>	<i>US units</i> <i>psi</i>
1. For all alloy steel shafts except tail shafts and tube shafts stated in 3 and 4 below.	800	81.5	116,000
2. For all carbon and carbon-manganese shafts except tail shafts and tube shafts stated in 3 and 4 below.	760	77.5	110,200
3. For tail shafts and tube shafts in oil lubricated bearings or in saltwater lubricated bearings but fitted with continuous liner or equivalent (see 4-3-2/5.17.6).	600	61.2	87,000
4. For tail shafts and tube shafts in saltwater lubricated bearings fitted with non-continuous liners.	415	42.2	60,000
5. For tailshafts and other shaft sections manufactured of age-hardened martenistic stainless steels, higher-strength austenitic stainless steels such as ASTM Type XM-19, XM-21 or XM-28 or other high strength alloy materials.	930	95.0	135,000

5.3 Hollow Shafts

For hollow shafts where the bore exceeds 40% of the outside diameter, the minimum outside shaft diameter is not to be less than that determined through successive approximation utilizing the following equation:

$$D_o = D \sqrt[3]{\frac{1}{[1 - (D_i / D_o)^4]}}$$

where

D_o = required outer diameter of shaft; mm (in.)

D = solid shaft diameter required by 4-3-2/5.1; mm (in.)

D_i = actual inner diameter of shaft; mm (in.)

5.5 Alternative Criteria

As an alternative to the design equations shown in 4-3-2/5.1 and 4-3-2/5.3, shafting design may be considered for approval on the basis of axial and torsional loads to be transmitted, bending moment and resistance against fatigue. A detailed stress analysis showing a factor of safety of at least 2.0 for fatigue failure is to be submitted for approval with all supporting data.

5.7 Key

In general, the key material is to be of equal or higher strength than the shaft material. The effective area of the key in shear is to be not less than A , given below. The effective area is to be the gross area subtracted by materials removed by saw cuts, set screw holes, chamfer, etc., and is to exclude the portion of the key in way of spooning of the key way.

Note: Keyways are, in general, not to be used in installations with slow speed, crosshead or two-stroke engines with a barred speed range.

$$A = \frac{D^3}{5.1r_m} \cdot \frac{Y_S}{Y_K}$$

where

- A = shear area of key; mm² (in²)
 D = line shaft diameter; mm (in.); as determined by 4-3-2/5.1
 r_m = shaft radius at mid-length of the key; mm (in.)
 Y_S = specified yield strength of shaft material; N/mm² (kgf/mm², psi)
 Y_K = specified yield strength of key material; N/mm² (kgf/mm², psi)

5.9 Strengthening for Navigation in Ice

For vessels to be assigned with **Ice Class** notations, shafting is to be designed in accordance with 6-1-5/53 or 6-1-6/27.

5.11 Tail Shaft Propeller-end Design

Tail shafts are to be provided with an accurate taper fit in the propeller hub, particular attention being given to the fit at the large end of the taper. In general, the actual contact area is to be at least 70% of the theoretical contact area. The key is to fit tightly in the keyway and be of sufficient size (see 4-3-2/5.7) to transmit the full torque of the shaft, but it is not to extend into the propeller hub counterbore (to accommodate the liner) on the forward side of the propeller hub. The forward end of the keyway is to be so cut in the shaft as to give a gradual rise from the bottom of the keyway to the surface of the shaft (see 4-3-2/Figure 2). Ample fillets (see Note 2 of 4-3-2/Table 1) are to be provided in the corners of the keyway and, in general, stress concentrations are to be reduced as far as practicable.

5.13 Propeller-end Seal

Effective means are to be provided to prevent water having access to the shaft at the part between the after end of the liner and the propeller hub and between the shaft and the propeller. See typical sealing arrangements in 4-3-2/Figure 2. See also 4-3-3/9.5.

FIGURE 2
Typical Arrangements and Details of Fitting of Tail Shaft and Propeller

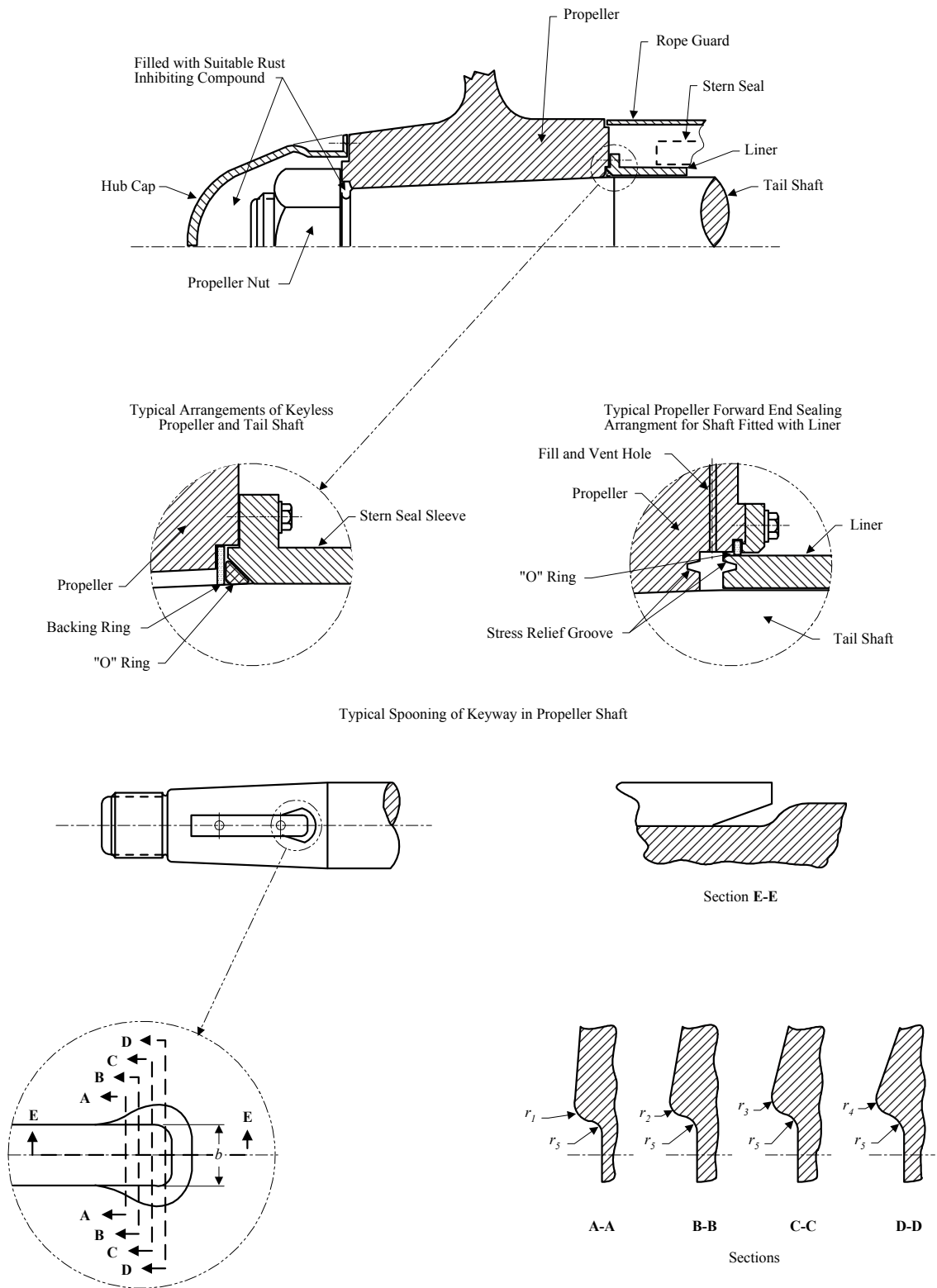

5.15 Tail Shaft Bearings

5.15.1 Water-lubricated Bearings

The length of the bearing, next to and supporting the propeller, is to be not less than four times the required tail-shaft diameter. However, for bearings of rubber, reinforced resins, or plastic materials, the length of the bearing, next to and supporting the propeller, may be less than four times, but not less than two times the required tail shaft diameter, provided the bearing design is being substantiated by experimental tests to the satisfaction of ABS.

5.15.2 Oil-lubricated Bearings

5.15.2(a) White metal. The length of white-metal-lined, oil-lubricated propeller-end bearings fitted with an approved oil-seal gland is to be not less than two times the required tail shaft diameter. The length of the bearing may be reduced, provided the nominal bearing pressure is not more than 0.80 N/mm² (0.0815 kgf/mm², 116 psi), as determined by static bearing reaction calculation taking into account shaft and propeller weight which is deemed to be exerted solely on the aft bearing, divided by the projected area of the bearing surface. The minimum length, however, is not to be less than 1.5 times the actual diameter.

5.15.2(b) Synthetic material. The length of synthetic rubber, reinforced resin or plastic oil-lubricated propeller end bearings fitted with an approved oil-seal gland is to be not less than two times the required tail shaft diameter. The length of bearing may be reduced, provided the nominal bearing pressure is not more than 0.60 N/mm² (0.0611 kgf/mm², 87 psi), as determined by static bearing reaction calculation taking into account shaft and propeller weight which is deemed to be exerted solely on the aft bearing, divided by the projected area of the bearing surface. The minimum length, however, is not to be less than 1.5 times the actual diameter. Where the material has demonstrated satisfactory testing and operating experience, consideration may be given to increased bearing pressure.

5.15.2(c) Cast iron or bronze. The length of oil-lubricated cast iron or bronze bearings which are fitted with an approved oil-seal gland is to be not less than four times the required tail shaft diameter.

5.15.2(d) Stern tube bearing oil lubricating system sampling arrangement. An arrangement for readily obtaining accurate oil samples is to be provided. The sampling point is to be taken from the lowest point in the oil lubricating system, as far as practicable. Also, the arrangements are to be such as to permit the effective removal of contaminants from the oil lubricating system.

5.15.3 Grease-lubricated Bearings

The length of grease-lubricated bearings is to be not less than four times the diameter of the required tail shaft diameter.

5.17 Tail Shaft Liners

5.17.1 Thickness at Bearings

5.17.1(a) Bronze liner. The thickness of bronze liners to be fitted to tail shafts or tube shafts is not to be less than that given by the following equation.

$$t = \frac{T}{25} + 5.1 \text{ mm} \quad \text{or} \quad t = \frac{T}{25} + 0.2 \text{ in.}$$

where

$$\begin{aligned} t &= \text{thickness of liner; mm (in.)} \\ T &= \text{required diameter of tail shaft; mm (in.)} \end{aligned}$$

5.17.1(b) Stainless steel liner. The thickness of stainless steel liners to be fitted to tail shafts or tube shafts is not to be less than one-half that required for bronze liners or 6.5 mm (0.25 in.), whichever is greater.

5.17.2 Thickness Between Bearings

The thickness of a continuous bronze liner between bearings is to be not less than three-fourths of the thickness required in way of bearings.

5.17.3 Liner Fitting

All liners are to be carefully shrunk or forced upon the shaft by pressure and they are not to be secured by pins. If the liner does not fit the shaft tightly between the bearing portions, the space between the shaft and liner is to be filled by pressure with an insoluble non-corrosive compound.

5.17.4 Glass Reinforced Plastic Coating

Glass reinforced plastic coatings may be fitted on propulsion shafting when applied by an approved procedure to the satisfaction of the Surveyor. Such coatings are to consist of at least four plies of cross-woven glass tape impregnated with resin, or an equivalent process. Prior to coating, the shaft is to be cleaned with a suitable solvent and grit-blasted. The shaft is to be examined prior to coating and the first layer is to be applied in the presence of the Surveyor. Subsequent to coating, the finished shaft is to be subjected to a spark test or equivalent to verify freedom from porosity to the satisfaction of the Surveyor. In all cases where reinforced plastic coatings are employed, effective means are to be provided to prevent water from gaining access to the metal of the shaft. Provisions are to be made for overlapping and adequately bonding the coating to fitted or clad liners. The end of the liner is to be stepped and tapered as required to protect the end of the wrapping.

5.17.5 Stainless Steel Cladding

Stainless steel cladding of shafts is to be carried out in accordance with Appendix 7-A-11 “Repair and Cladding of Shafts” of the *ABS Rules for Survey After Construction (Part 7)*.

5.17.6 Continuous Liner or Equivalent

Stainless steel cladding in 4-3-2/5.17.5 and metallic liners in 4-3-2/5.17.1, if of non-continuous construction but if the exposed shaft is protected with fiber glass reinforced plastic coating in accordance with 4-3-2/5.17.4, may be credited as “continuous” liners for purposes of:

- Determining required tail shaft and tube shaft diameters (see 4-3-2/5.1 and 4-3-2/5.3), and
- Periodical tail shaft survey [see 7-2-1/13.1.2(c)].

5.19 Couplings and Coupling Bolts

5.19.1 Fitted Bolts

The minimum diameter of fitted shaft coupling bolts is to be determined by the following equation. The bolts are to be assembled with an interference fit.

$$d_b = 0.65 \sqrt{\frac{D^3(U + c)}{NB U_b}}$$

where

B = bolt circle diameter; mm (in.)

c = constant, as given below

	<i>SI unit</i>	<i>MKS unit</i>	<i>US unit</i>
c	160	16.3	23,180

d_b = diameter of bolt at joints; mm (in.)

D = minimum required shaft diameter designed considering the largest combined torque (static and dynamic), acting at the shaft in vicinity of the respective coupling flanges; mm (in), see 4-3-2/7.5 but not less than the minimum required line shaft diameter (see 4-3-2/5.1); mm (in.)

N = number of bolts fitted in one coupling

- U = minimum specified tensile strength of shaft material, as defined in 4-3-2/5.1; N/mm² (kgf/mm², psi)
- U_b = minimum specified tensile strength of bolt material; N/mm² (kgf/mm², psi), subject to the following conditions:
- Selected bolt material is to have minimum specified tensile strength U_b at least equal to U .
 - Regardless of the actual minimum tensile strength, the value of U_b used in these calculations is not to exceed $1.7U$ nor 1000 N/mm² (102 kgf/mm², 145,000 psi).

5.19.2 Non-fitted Bolts

The diameter of pre-stressed non-fitted coupling bolts will be considered upon the submittal of detailed preloading and stress calculations and fitting instructions. The tensile stress of the bolt due to prestressing and astern pull is not to exceed 90% of the minimum specified yield strength of the bolt material. In addition, the bearing stress on any member such as the flange, bolt head, threads or nut is not to exceed 90% of the minimum specified yield strength of the material of that member.

For calculation purpose, to take account of torsional vibratory torque, the following factors may be applied to the transmitted main torque, unless the actual measured vibratory torque is higher, in which case, the actual vibratory torque is to be used:

- For direct diesel engine drives: 1.2
- For all other drives and for diesel engine drives with elastic coupling: 1.0

5.19.2(a) Torque transmission by friction. Where torque is to be transmitted by friction provided by prestressed non-fitted bolts only and the bolts are under pure tension, the factor of safety against slip under the worst operating conditions, including mean transmitted torque plus torque due to torsional vibration, is to be at least as follows:

- Inaccessible couplings (external to the hull or not readily accessible): 2.8
- Accessible couplings (internal to the hull): 2.0

5.19.2(b) Torque transmission by combined friction and shear. Where torque is to be transmitted by combination of fitted bolts and prestressed non-fitted bolts, the components are to meet the following criteria:

- Fitted bolts.* The shear stress under the maximum torque corresponding to the worst loaded condition is to be not more than 50% of the minimum specified tensile yield strength of the bolt material.
- Non-fitted bolts.* The factor of safety against slip, under the maximum torque corresponding to the worst loaded condition and the specified bolt tension, is to be at least 1.6 for inaccessible couplings and 1.1 for accessible couplings.

5.19.2(c) Torque transmission by dowels. Dowels connecting the tail shaft flange to the controllable pitch propeller hub, utilized with prestressed non-fitted bolts to transmit torque, are considered equivalent to fitted bolts and are to comply with 4-3-2/5.19.1 and, if applicable, 4-3-2/5.19.2(b). The dowels are to be accurately fitted and effectively secured against axial movement.

5.19.3 Flanges

5.19.3(a) Flange thickness. The thickness of coupling flanges integral to the shaft is not to be less than the minimum required diameter of the coupling bolts or $0.2D$, where D is as defined in 4-3-2/5.1, whichever is greater.

The fillet radius at the base of a coupling flange is not to be less than 0.08 times the actual shaft diameter. Consideration will be given to fillets of multiple radii design; such fillet is normally to have a cross-sectional area not less than that of a required single-radius fillet. In general, the surface finish for fillet radii is not to be rougher than 1.6 μm (63 μin) RMS. Alternatively, 1.6 μm CLA (center line average) may be accepted.

5.19.3(b) Flange thickness – connection to controllable pitch propeller. The thickness of the coupling flange integral to the tail shaft for connection to the forward face of the controllable pitch propeller hub is to be not less than 0.25D, where D is as defined in 4-3-2/5.1.

For the tail shaft flange supporting the propeller, the fillet radius at the base of the flange is to be at least 0.125D. Special consideration will be given to fillets of multiple-radius design; see 4-3-2/5.19.3(a). The fillet radius is to be accessible for nondestructive examination during tail shaft surveys. See 7-5-1/3.5.

5.19.4 Demountable Couplings

The strength of demountable couplings and keys is to be equivalent to that of the shaft. Couplings are to be accurately fitted to the shaft. Where necessary, provisions for resisting thrust loading are to be provided.

Hydraulic and other shrink fit couplings will be specially considered upon submittal of detailed preload and stress calculations and fitting instructions. In general, the torsional holding capacity under nominal working conditions and based on the minimum available interference fit (or minimum pull-up length) is to be at least 2.8 times the transmitted mean torque plus torque due to torsional vibration (see 4-3-2/5.19.2) for inaccessible couplings (external to the hull or not readily accessible). This factor may be reduced to 2.0 times for accessible couplings (internal to the hull). The preload stress under nominal working conditions and based on the maximum available interference fit (or maximum pull-up length) is not to exceed 70% of the minimum specified yield strength.

The following friction coefficients are to be used:

Oil injection method of fit:	0.13
Dry method of fit:	0.18

5.19.5 Flexible Couplings

5.19.5(a) Design. Flexible couplings intended for use in propulsion shafting are to be of approved designs. Couplings are to be designed for the rated torque, fatigue and avoidance of overheating. Where elastomeric material is used as a torque-transmitting component, it is to withstand environmental and service conditions over the design life of the coupling, taking into consideration the full range of maximum to minimum vibratory torque. Flexible coupling design will be evaluated, based on submitted engineering analyses.

5.19.5(b) Torsional displacement limiter. Flexible couplings with elastomer or spring type flexible members, whose failure will lead to total loss of propulsion capability of the vessel, such as that used in the line shaft of a single propeller vessel, are to be provided with a torsional displacement limiter. The device is to lock the coupling or prevent excessive torsional displacement when a pre-determined torsional displacement limit is exceeded. Operation of the vessel under such circumstances may be at reduced power. Warning notices for such reduced power are to be posted at all propulsion control stations.

5.19.5(c) Barred range. Conditions where the allowable vibratory torque or the allowable dissipated power may be exceeded under the normal operating range of the engine are to be identified and are to be marked as a barred range in order to avoid continuous operation within this range.

5.19.5(d) Impact Torque. Flexible couplings for generator sets or motors are to be capable of absorbing short time impact torque due to electrical short-circuit conditions up to 6 (six) times the nominal torque, or the couplings are to be evaluated for capability to absorb the torque generated by transient torsional vibration stresses..

5.19.6 Clutches

5.19.6(a) *Design.* Clutches intended for use in propulsion shafting are to be of approved design. They are to be designed to transmit the maximum power at rated speed. The minimum service factor, determined by the ratio of the clutch static holding capacity to the rated torque, is to be as follows:

<i>Clutch Design Type</i>	<i>Minimum Service Factor</i>
Drum-type clutch or Disc type, air-actuated, air cooled clutches	
Shafting system fitted with fixed pitch propeller	1.7
Shafting system fitted with fixed pitch propeller and shaft brake	1.5
Shafting system fitted with controllable pitch propeller	1.5
Hydraulically-actuated, oil cooled multiple-plate clutches	1.7

The minimum service factor will be required to be increased if the shafting vibratory torque is excessive, clutch thermal capacity is exceeded because of frequent clutch engagements during vessel operations, the clutch shoe material used has limited service experience or the clutch will be allowed to slip during vessel operations. Calculations are to be submitted for review.

5.19.6(b) *System arrangements.* Arrangements are to be made such that, in the event of failure of the clutch actuating system, each clutch remains capable of being engaged and transmitting an adequate power considered necessary for propulsion and maneuvering of the vessel.

5.19.6(c) *Coupling bolts.* Coupling bolts are to comply with 4-3-2/5.19.1 and 4-3-2/5.19.2 and are to be of sufficient strength to support the weight of the elements, as well as to transmit all necessary forces.

5.19.7 Locking Arrangement

After assembly, all coupling bolts and associated nuts are to be fitted with locking arrangement.

5.21 Cardan Shaft

Cardan shafts are to be designed in accordance with the equation for propulsion shaft in 4-3-2/5.1, and flanges and bolts are to be in accordance with 4-3-2/5.19.1, 4-3-2/5.19.2 and 4-3-2/5.19.3. The design of splines, yokes and cross-members are to be evaluated based on engineering analyses which are to be submitted for review. Where applicable, the cardan shaft assembly is to contain provisions for bearing thrust or pull from the propeller.

7 Propulsion Shaft Alignment and Vibrations

7.1 General

In addition to the design requirements addressed above, additional stresses in the shafting system resulting from the shaft alignment in relation to the location and spacing of the shaft bearings, and by axial, whirling and torsional vibrations are to be evaluated and comply with this section.

7.3 Shaft Alignment for Vessels 61 m (200 ft) in Length and Over

7.3.1 Submission of Calculations and Procedures

7.3.1(a) Shaft alignment calculations, alignment procedures, and stern tube boring details, as applicable, are to be submitted for review for:

- i) Propulsion shafting of diameter greater than 300 mm (11.81 in.)
- ii) Propulsion shafting with no forward stern tube bearing

The calculations, alignment procedures, and stern tube boring details for these shafting arrangements are to comply with 4-3-2/7.3.2 through 4-3-2/7.3.4.

7.3.1(b) Shaft alignment calculations for all other types of installations are only required to be submitted for reference.

7.3.2 Shaft Alignment Calculations

7.3.2(a) The alignment calculations are to include bearing reactions, shear forces and bending moments along the shafting and are to be performed for the maximum allowable alignment tolerances. The analysis is to show that:

- i) Bearing loads under all operating conditions are within the acceptable limits specified by the bearing manufacturer.
- ii) Bearing reactions are always positive (i.e., supporting the shaft), except as determined acceptable in accordance with 4-3-2/11.1.2(e)v).
- iii) Shear forces and bending moments on propulsion equipment are within the limits specified by manufacturers.
- iv) Shear forces and bending moments at the crankshaft flange are in accordance with the engine manufacturer's limits.

Moreover, the shaft alignment calculations are to include the following (as applicable):

- v) *Geared Systems.* In case of geared systems, the calculated misalignment between main gear and pinion is to be less than $0.1 \cdot 10^{-3}$ [rad] unless the verification and adjustment procedure of misalignment between main gear and pinion are submitted for reference (i.e., the foregoing misalignment is verified by the tooth contact pattern in the case of no load condition during installation and by load condition during shipboard trial).
- vi) *Misalignment Slope.* The designed relative misalignment slope between the shaft and the tail shaft bearing is to be positive, and not to exceed $0.3 \cdot 10^{-3}$ [rad].
- vii) *Stern Tube Bearing Fitting.* Based on the actual interference fit tolerances, the stern tube bearing fitting calculation, including fitting pressure and push-in distance, is to be submitted for review.
- viii) *Tail Shaft Bearing Clearance Calculation.* A clearance calculation, on aft and forward stern tube bearing, with alignment model showing only the propeller shaft on two stern tube bearings, is to be included in the shaft alignment analysis report and submitted to ABS for review. In installations with no forward stern tube bearing, a temporary support is to be utilized in place of the forward stern tube bearing.

In addition, the shaft alignment analysis is to identify:

- ix) Sag and gap data and temporary support location corresponding to the condition(s) in which they will be measured
- x) Jack up locations

7.3.2(b) *Hull Deflections Accounted for in the Analysis.* The vessel conditions to be considered in the analysis are to account for the following:

- i) Drydock or after launching draft at cold static condition
- ii) Full ballast draft at hot static condition (aft peak tank full, as applicable)
- iii) Fully laden draft at hot static condition

7.3.2(c) *Hull Deflections NOT Accounted for in the Analysis.* Where the hull deflections are not accounted for in the analysis then the shaft alignment verification is to comply with 4-3-2/11.1.2(e)iv). Vessels where cargo/ballast load change is not significantly affecting the draft of the ship will be given special consideration. In no case are the calculated bearing reactions to exceed 80% of the maximum allowable manufacturer's limit.

7.3.3 Stern Tube Slope Boring

- i) If the calculated relative misalignment slope between the shaft and the tail shaft bearing is greater than $0.3 \cdot 10^{-3}$ [rad], the relative misalignment slope is to be reduced by means of slope-boring or bearing inclination.

- ii) The slope boring angle calculation (single or double slope) is to be based on a static afloat condition with a hot engine and fully immersed propeller. Also see 4-3-2/7.3.2(a)vi above.
- iii) The slope boring verification procedure is to be submitted for review.
- iv) An aft stern tube bearing double slope boring design is to have the transition point between two slopes located in between $D/3$ and $L/4$ distance from the aft bearing edge. The slope design angles are to be such to result in heaviest reaction load at the point of the slope transition, and as close to zero load as possible at the aft and forward edge of the bearing.

D = actual shaft diameter

L = length of aft stern tube bearing

7.3.4 Shaft Alignment Procedure

The shaft alignment procedure is to be submitted for review and is to be based on the submitted shaft alignment calculations. As a minimum, the shaft alignment procedure is to include:

- i) *Bore Sighting*. The bore sighting procedure is to be conducted in two stages, as follows:
 - Bore sighting before bearings fitting (not applicable for stern tube bearings installed by resin chocking), is to be conducted on the stern tube bore to verify:
 - The stern tube bore dimensions; in order to define dimensions and tolerance for the aft and the forward stern tube bush outside diameters machining
 - The stern tube bore misalignment, vertical and horizontal; in order to define angular corrections for stern tube bearing outside diameter machining

Whenever applicable, all corrections are to be done by machining the outside bush diameter, rather than correcting the stern tube bore, unless otherwise approved.

- Bore sighting after the stern tube bearings are fitted, is to verify:
 - The aft bush slope, as-installed. The measurement is to be taken with reference to the forward stern tube bush.
 - The horizontal misalignment between aft and the forward stern tube bearing

In cases with no forward stern tube bearing, the intermediate shaft bearing should serve as a referent point to conduct sighting.

Sufficient number of targets are to be utilized during the sighting through to establish accuracy in verification of bearing slopes. The sighting target arrangement is to be included in the procedure submitted for review.

The bore sighting is to confirm:

- The horizontal misalignment of all bearings is to be minimized and is not to exceed the clearance of adjacent bearings.
 - The slope boring angle is to be verified relative to the centerline connecting the aft and the forward stern tube bearing, or the intermediate shaft bearing in installations with no forward stern tube bearing. Acceptable tolerance is up to $\pm 0.1 \cdot 10^{-3}$ [rad], with the following restriction:
 - The measured slope boring angle is never to result in misalignment greater than $0.3 \cdot 10^{-3}$ [rad].
- ii) *Installations with no Forward Stern Tube Bearing*. The following requirements are to be fulfilled in installations with no forward stern tube bearings:
 - The aft stern tube bearing is to be of the double slope design that provides compliance with 4-3-2/7.3.3. A single slope design may be specially considered where adequate technical documentation is submitted to justify that a single slope design would provide an equivalent or better design.

- The aftmost intermediate shaft bearing is to serve as the second fixed point of reference when sighting is conducted.
 - The intermediate shaft bearing is to be chocked and its offset not changed after the bore sighting is complete, except as agreed to by the attending Surveyor based on the clearance measurements identified in 4-3-2/7.3.4iv) below.
 - The forced stern tube lubrication system is to be designed with the lubricant supply entering at the aft of the aft stern tube bearing.
- iii) *Stern Tube Bearing Fitting Pressure Verification.* The stern tube bearing fitting pressure is to be verified to comply with calculated values.
- iv) *Tail Shaft Bearing Clearance Measurement.* The clearance between the propeller shaft and the stern tube bearings is to be measured after the propeller shaft is fitted, before propeller is installed, and with shaft unrestrained on the forward flange. The Surveyor is to verify that the final alignment does not exceed the criteria identified in 4-3-2/7.3.4i) (2nd bullet).
- v) *Sag and Gap.* The sag and gap procedure is to be verified against the respective analysis (e.g., based on dry dock or light ship draft condition). Acceptable tolerances are ± 0.1 mm.
- vi) *Bearing Load Measurements.* Identification of the bearings at which the measurements are to be taken, the jack up locations, the data to be recorded and the procedures to be followed is to be reported in the submittal.

7.5 Torsional Vibrations

7.5.1 Allowable Torsional Vibration Stress

The torsional vibration stress in the propulsion shafting system is not to exceed the allowable vibratory stress, S , given in 4-3-2/Table 4. The analysis of torsional vibrations shall account for stresses resulting from vector summation of responses (synthesis) of all relevant excitation harmonics.

The stress limit S is applicable for propulsion shafting systems, including types of couplings, dampers, clutches, etc., where torsional vibratory torque is the only load of significance.

For propulsion shafts, and equipment integral to the shaft, where vibratory torque is not the only significant source of load, the stress limit S does not apply. Design criteria of such shafts are contained in the following applicable sections:

- i) Crankshafts: see 4-2-1/5.9,
- ii) Turbine rotor shafts: see 4-2-3/5.1, and 4-2-4/5.3
- iii) Gear shafts: see 4-3-1/5.9
- iv) Electric motor shafts: see 4-8-3/3.11
- v) Generator shafts: see 4-8-3/3.11
- vi) Other shafts and equipment that falls under the subject criteria need to be designed considering maximum combined load acting within operating speed range of the propulsion system.

TABLE 4
Allowable Torsional Vibratory Stress

	<i>SI units</i>	<i>MKS units</i>	<i>US units</i>
S = allowable vibratory stress	$\frac{U + 160}{18} C_K C_D C_r$ N/mm ²	$\frac{U + 16.3}{18} C_K C_D C_r$ kgf/mm ²	$\frac{U + 23180}{18} C_K C_D C_r$ psi
U = minimum tensile strength of shaft material	To be taken as not more than 600 N/mm ² (see Note)	To be taken as not more than 61.2 kgf/mm ² (see Note)	To be taken as not more than 87,000 psi (see Note)
C_K = shaft design factor	See 4-3-2/Tables 1 and 2.		
C_D = size factor	$0.35 + \frac{0.93}{\sqrt[5]{d}}$	$0.35 + \frac{0.93}{\sqrt[5]{d}}$	$0.35 + \frac{0.487}{\sqrt[5]{d}}$
d = actual shaft diameter	mm	mm	in.
C_r = speed ratio factor	$3 - 2\lambda^2$ for $\lambda < 0.9$; 1.38 for $0.9 \leq \lambda \leq 1.05$		
λ	$\lambda = \frac{\text{Critical Speed (RPM) at which vibratory stress is calculated}}{\text{rated speed (RPM)}}$		

Note: Regardless of the actual minimum specified tensile strength of the shaft (tail shaft, tube shaft, line shaft and crankshaft, as applicable) material, the value of U used in these calculations is not to exceed the values indicated. Higher values of U , but not exceeding 800 N/mm² (81.5 kgf/mm², 116,000 psi), may be acceptable for the line shaft, subject, for example, to satisfactory fatigue assessment for the line shaft, see 4-3-2/Appendix 1.

7.5.2 Diesel Engine Installations

For diesel engine installations, vibratory stresses are to be calculated with any one cylinder not firing and the calculations are to be submitted for information.

7.5.3 Barred Speed Ranges

When torsional vibratory stresses exceed the foregoing limits at an rpm within the operating range but less than 80% of rated speed, a barred range is to be provided. The allowable vibratory stress in a barred range due to the alternating torsional vibrations is not to exceed the values given by the following:

$$S_2 = \frac{1.7S}{\sqrt{C_k}} \quad \text{for } \lambda \leq 0.8$$

where

$$S_2 = \text{allowable vibratory stress within a barred range, N/mm}^2 \text{ (kgf/mm}^2 \text{, psi)}$$

λ , S , C_k are as defined in 4-3-2/7.5.1.

Where shafts may experience vibratory stresses close to the permissible stresses for transient operation, the shaft material is to have a specified minimum ultimate tensile strength of not less than 500 N/mm² (50.9 kgf/mm², 72,500 psi). Otherwise materials having a specified minimum ultimate tensile strength of not less than 400 N/mm² (40.8 kgf/mm², 58,000 psi) may be used.

Barred ranges are not acceptable in the speed range between 0.8 and 1.05 of the rated speed. The existence of a barred range at speeds less than 0.8 of the rated speed is to be considered in establishing standard operating speeds for the vessel. The width of the barred range is to take into consideration the breadth and severity of the critical speed but is not to be less than the following limits:

$$\frac{16n_c}{18 - \lambda} \geq n_\ell \quad \text{and} \quad \frac{(18 - \lambda)n_c}{16} \leq n_u$$

where

$$n_c = \text{critical speed}$$

$$n_\ell = \text{lower limit}$$

$$n_u = \text{upper limit}$$

λ is as defined in 4-3-2/Table 4.

7.5.4 Marking of Tachometer and Alarms

Where a barred speed range is identified as in 4-3-2/7.5.3, the tachometer is to be marked and a warning notice is to be displayed at all propulsion control stations (local and remote) to caution that operation in the barred range is to be avoided except for passing through. Where remote propulsion control is fitted on the navigation bridge or where a centralized control station is fitted, means are to be provided at these remote propulsion control stations to alert the operator of any operation of the propulsion drive within the barred range. This may be achieved by a visual display or alarm.

7.5.5 Other Effects

Because critical torsional vibration has deleterious effects other than shafting fatigue, the limits in 4-3-2/7.5.1 are not intended for direct application as design factors, and it is desirable that the service range above 90% of rated speed be kept clear of torsional critical speeds insofar as practicable.

7.5.6 Torsiograph Tests

When the calculation indicates that criticals occur within the operating range, whose severity approaches or exceeds the limits in 4-3-2/7.5.1, torsiograph tests may be required to verify the calculations and to assist in determining ranges of restricted operation.

7.5.7 Vibration Dampers

When torsional vibratory stresses exceed the limits in 4-3-2/7.5.1 and a barred range is not acceptable, the propulsion system is to be redesigned or vibration dampers are to be fitted to reduce the stresses.

7.5.8 Gears

When the propeller is driven through reduction gear, or when geared booster power or power take-off is provided, a barred range is to be provided at the acceptable critical speed if gear tooth chatter occurs during continuous operation at this speed.

7.7 Axial Vibrations

The designer or the builder is to evaluate the shafting system to ensure that axial vibration characteristics in association with diesel engine or propeller blade-rate frequency forces will not result in deleterious effects throughout the engine operating speed range, with consideration also given to the possibility of the coupling of torsional and axial vibration, unless experience with similar shafting system installations makes it unnecessary. The axial vibrations may be controlled by axial vibration detuners to change the natural frequency of the system or by axial vibration dampers to limit the amplitude of axial vibrations to an acceptable level.

When on the basis of axial vibration calculations the designer or builder proposed to provide barred speed ranges within the engine operating speed range, the calculations are to be submitted for information. The barred speed ranges due to axial vibrations are to be verified and established by measurement.

7.9 Whirling Vibrations

7.9.1 General (1 July 2018)

Calculations are to be carried out for all main propulsion shafting systems and are to ensure that whirling vibration characteristics are satisfactory throughout the speed range. In addition, calculations of the whirling vibrations for the following arrangements are to be submitted for review:

- i) Shafting systems without a forward stern tube bearing or without an intermediate bearing.
- ii) Shafting systems whose bearing span exceeds $450\sqrt{d}$, where d is the actual shaft diameter in mm of the tail shaft or intermediate shaft, whichever is less.
- iii) Shafting systems having supports outboard of the hull (e.g., A-or P-brackets).
- iv) Shafting systems incorporating Cardan shafts
- v) **Shafting systems incorporating propellers with five (5) blades or more.**

7.9.2 Calculations

7.9.2(a) The calculations in 4-3-2/7.9.1, are to take into account bearing and oil-film stiffness and are to investigate the excitation frequencies giving rise to all critical speeds which may result in significant vibration amplitudes within the speed range.

7.9.2(b) (1 July 2018) Where calculations, as per 4-3-2/7.9.2(a), indicate the possibility of whirling **critical speeds** within the range of $\pm 20\%$ of maximum continuous ratings (M.C.R.) speed, measurements using an appropriate recognized technique may be required to be taken from the shafting system for the purpose of determining the need for barred speed ranges.

7.11 Vessels Below 61 m (200 ft) in Length

7.11.1 Torsional Vibration.

For vessels fitted with an unusual propulsion arrangement or without vibration dampers, a torsional vibration analysis of the propulsion system showing compliance with 4-3-2/7.5.1 is to be submitted. This is not required for vessels under 20 m (65 ft) in length or where the installation is essentially the same as previous designs which have been proven satisfactory.

9 Inspection, Testing and Certification

9.1 General

Shafting components are to be inspected, tested and certified by a Surveyor at the plant of the manufacturer in accordance with the following requirements.

9.3 Material Testing

For testing of shafting component materials, see 4-3-2/3.7.

9.5 Propulsion Shafts and Associated Parts

9.5.1 Power Transmitting Parts

All propulsion shafts and associated parts, such as coupling bolts, are to be visually examined for surface flaws, out of roundness, straightness, and dimensional tolerances. The Surveyor, in case of doubts, may require additional nondestructive testing. See 4-3-2/3.7.3 for tail shaft requirements.

9.5.2 Liners

Shaft liners are to prove tight under hydrostatic test of 1.0 bar (1 kgf/cm², 15 psi). After assembly, the fit of the liner to the shaft is to be checked for freedom from voids. Any void in way of bearings is to be dealt with as in 4-3-2/5.17.3.

9.7 Flexible Couplings, Clutches, Cardan Shafts, etc.

Manufactured torque transmitting parts, such as flexible couplings, clutches (independent of the gear assembly), cardan shafts, etc. are to be inspected, tested, and certified by a Surveyor at the plant of manufacture. Alternatively, these parts may be certified under Type Approval Program (see 1-1-4/7.7).

11 Installation and Trials

11.1 Shaft Alignment

11.1.1 All Vessels

The shaft alignment is to be carried out in the presence of a Surveyor. The alignment is to be verified in the afloat condition with superstructure in place and major welding work completed and is to be to the satisfaction of the attending Surveyor.

11.1.2 Vessels with Shafting Arrangements Identified in 4-3-2/7.3.1(a)

11.1.2(a) Alignment Verification. The alignment verification is to be carried out in accordance with the procedures addressed in 4-3-2/7.3.4. The alignment calculated data is to be verified and recorded, in the presence of the Surveyor for the following:

- i) Stern tube sighting and slope boring (as applicable) before shaft fitting
- ii) Stern tube bearing fitting pressure and push-in distance, as identified in 4-3-2/7.3.4iii)
- iii) Stern tube bearing clearance, as identified in 4-3-2/7.3.4iv)
- iv) Sag and gap
- v) Bearing reaction

11.1.2(b) Stern Tube Bearing Run-in Procedure. For shaft installations with no forward stern tube bearings and for shaft installations with stern tube bearings having a double-slope boring, a bearing run-in procedure is to be submitted by the builder/designer and the same is to be carried out to the satisfaction of the attending Surveyor before the stern tube bearings are exposed to higher service speeds and rudder angles.

11.1.2(c) Stern Tube Sighting and Slope Boring (as Applicable) before Shaft Fitting

- i) Maximum allowable slope boring angle deviation is not to result in negative slope, and is never to exceed relative misalignment slope of $0.3 \cdot 10^{-3}$ [rad].
- ii) In case of a propulsion installation with no forward stern tube bearing, the stern tube bore sighting and slope boring are to be conducted as identified in 4-3-2/7.3.
- iii) In cases where sighting through and bearing positioning are conducted in block stage of the vessel construction, the verification of the following procedures is required:
 - a) Slope boring angle (as applicable)
 - b) Bearing vertical offset positioning
 - c) Engine vertical offset positioning
 - d) Sag and gap procedure.
- iv) If a monitoring system is installed to verify the stern tube bearing misalignment then consideration to waive some of the above requirements can be given.

11.1.2(d) Sag and Gap Verification

- i) The sag and gap is to be measured at the drydock or after launching condition, unless agreed to otherwise by ABS.
- ii) With assistance of the temporary supports the sag and gap needs to be simultaneously verified at all open flanges until sag and gap values are brought within acceptable tolerances of ± 0.1 mm from the corresponding calculated values.

11.1.2(e) Bearing Load Verification

- i) The bearing load measurements are to be carried out at the drydock or lightship condition, unless agreed to otherwise by ABS.
- ii) Bearing reactions are required to be verified and recorded by such means as hydraulic jack and/or strain gauge method on all accessible shafting bearings namely:
 - a) Forward stern tube bearing
 - b) Intermediate shaft bearing(s)
 - c) Minimum three aftmost main engine bearings (for directly coupled propulsion systems only)
 - d) Main-gear shaft bearing

- iii) Where hull deflections are accounted for in the analysis:
 - a) The measured values for the bearings identified in 4-3-2/11.1.2(e)i) are to be within $\pm 20\%$ of the calculated values, unless specifically approved otherwise.
 - b) For the first vessel in series, in addition to 4-3-2/11.1.2(e)i-ii) requirements bearing load measurements are to be taken for at least one additional service draft condition per 4-3-2/7.3.4vi).
 - c) In the case that the measured values are not within the prescribed tolerance identified in 4-3-2/11.1.2(e)iii)a), the shaft alignment calculations are to be revised so as to reflect compliance and re-submitted, or the provisions of 4-3-2/11.1.2(e)iv) followed.
- iv) Where hull deflections are NOT accounted for in the analysis, in addition to 4-3-2/11.1.2(e)i-ii), bearing load measurements are to be taken in at least one additional service draft condition of the vessel such as the full ballast draft [see 4-3-2/7.3.2(b)ii)], fully laden draft [see 4-3-2/7.3.2(b)iii)], or other service condition as determined acceptable by ABS as deemed necessary. In no case are the measured bearing reactions to exceed 80% of the maximum allowable manufacturer's limit.
- v) In the case that measurements in a particular service condition indicate that one of the bearings is unloaded, additional measurements and analyses, (such as whirling analysis) will be required to confirm unloading of the bearing has no adverse effect on vessel operation.
- vi) Additional bearing load measurements may be required, as determined necessary by ABS.

11.1.2(f) *Geared Systems.* In the case that the verification and adjustment procedure identified in 4-3-2/7.3.2(a)v) are submitted, the misalignment between main gear and pinion is to be verified and recorded to the satisfaction of the Surveyor.

11.1.3 Cast Resin Chocks

Resin chocks, intended for chocking of the shaft bearing foundation or stern tube, are to be of an approved type (see 1-1-A3/5 for type approval). Resin chocks are not to be relied upon to maintain watertight integrity of the hull or the oiltight integrity of the lubricating oil system. Accordingly, direct contact of resin chocks with water or oil is to be avoided. Where used, the arrangements and installation procedures are to be in accordance with the manufacturer's recommendations.

Arrangements of the proposed installation, along with installation parameters such as deadweight, holding-down bolt tightening torque, etc., and calculations showing that the manufacturer's specified allowable pressure is not exceeded, are to be submitted for review in each case.

11.3 Vibration Measurement

11.3.1 Torsional Vibration

Where torsionograph measurement is required as per 4-3-2/7.5.6, the measurement is to be taken in the presence of a Surveyor.

When a barred speed range is provided in accordance with 4-3-2/7.5.3, tachometer marking, warning notice, and alarms at remote control stations (where fitted), as described in 4-3-2/7.5.4, are to be fitted.

Electronic speed regulating devices may be preset to step-pass the barred range in addition to the warning notice.

When the propeller is driven through reduction gears, the Surveyor is to ascertain that no gear-tooth chatter occurs throughout the operating range. Otherwise, a barred speed range as per 4-3-2/7.5.3 is to be provided; see 4-3-2/7.5.8.

11.3.2 Axial Vibrations

When calculations indicate that barred speed ranges are present as per 4-3-2/7.7, these barred speed ranges are to be verified and recorded by appropriate measurement procedures in the presence and to the satisfaction of a Surveyor.

11.3.3 Measurements for Whirling Vibrations (1 July 2018)

Where calculations, as per 4-3-2/7.9.2(b), indicate the possibility of **whirling critical speeds** within the range of $\pm 20\%$ of maximum continuous ratings (M.C.R.) speed, measurements using an appropriate recognized technique may be required to be taken from the shafting system for the purpose of determining the need for barred speed ranges.

11.5 Circulating Currents

Where means are provided to prevent circulating currents from passing between the propeller, shaft and the hull, a warning notice plate is to be provided in a visible place cautioning against the removal of such protection.

11.6 Watertight Bulkhead Penetrations for Shafting

Where a propulsion shaft penetrates a watertight bulkhead, arrangements are to be made to maintain the watertight integrity of the bulkhead. The penetration arrangement is to provide a liquid tight seal in both directions of the bulkhead.

11.7 Sea Trial

The shafting installation is to be tested during sea trials under various maneuvering conditions. It is to be free from dangerous vibration and to the satisfaction of the Surveyor.

13 Tailshaft Condition Monitoring (TCM)

13.1 Notation

Where requested by the Owner, the class notation **TCM (Tailshaft Condition Monitoring)** may be assigned to a vessel with tailshafts specifically arranged with oil-lubricated stern tube bearings, provided the following requirements are complied with.

13.3 System Requirements

In addition to the requirements for propulsion shafting in Section 4-3-2, the following design requirements are to be complied with and relevant drawing(s) and data are to be submitted for review and approval prior to commencement of the initial surveys as specified in 4-3-2/13.7.1.

13.3.1 Temperature Monitoring and Alarm

The vessel is to be provided with a temperature monitoring and alarm system for the tailshaft stern tube aft bearing. The system is to be arranged with a high temperature alarm and two sensors. One easily interchangeable sensor may be installed in lieu of the two sensors. Where one interchangeable sensor is installed, one spare sensor is to be carried onboard the vessel.

The monitoring and alarm system is to have the following features:

- i) The main alarm system is to be provided with a power failure alarm.
- ii) An alarm that indicates an open circuit, a short circuit, or an earth fault in the temperature sensor circuit is to be provided
- iii) An alarm indicating that the sensor's temperature signal is outside the set points of the unit is to be provided.

Temperature monitoring and the alarm system are to be located in the propulsion machinery spaces. For **ACC/ACCU** machinery spaces, the temperature monitoring and alarm system is to be incorporated with the required control and monitoring system.

When a centralized control or monitoring station is installed, the alarms are to be activated in such a station.

13.3.2 Oil Seal Design

Approved type oil seals are to be used which will allow for replacement without the shaft withdrawal or removal of the propeller.

13.3.3 Bearing Wear Down Measurement

Arrangements and means are to be provided for bearing wear down measurement.

13.5 Management of the Monitored Data

The following management of the monitored data is to be implemented.

13.5.1 Lubrication Oil Sampling

Stern tube bearing lubricating oil is to be sampled monthly under service conditions, and analyzed for water content using a suitable on-board test kit. Additionally, at least every six months, oil samples are to be submitted for analysis to a recognized laboratory where testing is to be conducted for the following:

- i) Free water content in oil, if present
- ii) Bearing metals content (Pb, Fe, Cu, Al, Cr, Sn, Si, Ni)
- iii) Viscosity at 40°C

13.5.2 Stern Tube Bearings Operating Condition

Stern tube bearing temperatures are to be monitored and temperature recorded daily. The system's oil consumption is to be recorded monthly.

13.5.3 Recording and Analysis

The chief engineer is responsible for recording and maintaining a file of the shipboard performed lubricating oil sampling and analysis results, as well as stern tube bearings operating condition. Also, the results of the laboratory analysis are to be stored within the file onboard. All documentation is to be available to the Surveyor to allow for trend assessment of the measured parameters.

The shipboard record is to contain conclusions regarding the condition of the oil and whether it remains suitable for further use. Conclusions are to be supported by comparative parameters.

In case of oil replacement, a record containing the reason for replacement of the oil is to be maintained for Surveyor's review at the next Annual Survey.

13.7 Surveys

13.7.1 Initial Survey

All systems in 4-3-2/13 are to be examined and tested to the satisfaction of the attending Surveyor in accordance with the approved plans.

For initial survey of existing vessels, refer to 7-9-20/1.3 of the *ABS Rules for Survey After Construction (Part 7)*.

13.7.2 Survey After Construction

Refer to Section 7-9-20 of the *ABS Rules for Survey After Construction (Part 7)*.

15 Tailshaft Condition Monitoring (TCM-W) (1 July 2018)

15.1 Notation

Where requested by the Owner, the class notation **TCM-W (Tailshaft Condition Monitoring - Water Lubricated)** may be assigned to a vessel with tailshafts specifically arranged with closed or opened type water-lubricated stern tube bearings, provided the following requirements are complied with.

Exposed open water-lubricated bearings installed in an I or V shaped shaft struts without forced lubricating systems are not within the scope of this notation.

15.3 System Requirements

15.3.1 General

15.3.1(a) Bearing Material. The bearing material is to be approved by ABS.

15.3.1(b) Corrosion Protection. Approved corrosion-resistant material or a corrosion protection coating are to be used for propeller shaft, stern tube and all seal components (exposed to seawater) of the shaft including other metal structures exposed to the lubricant.

15.3.1(c) Pumping and Piping. The requirements listed in 4-3-2/15.3 for pumping and piping systems associated with the water lubricated system are in addition to those listed in Part 4, Chapter 6 of these Rules.

i) Pumps

- A minimum of two pumps, with an auto change over system, is to be provided for each propeller shaft.
- In case of multi-propeller shafts, at least one pump for each shaft is to be provided and one additional stand-by pump for the combined arrangement.
- Each pump is to be able to operate the system independently.
- Pumps should be able to operate from both local and main control stations.

ii) Lubricant Piping

- Independent lubricating piping systems are to be provided for each propeller shaft so as to maintain continuous operation of the vessel.
- Interconnection of lubricating piping systems will be acceptable where multi-propeller shafts are used, provided appropriate isolation valves are fitted at both sides of the piping system.
- Non-metallic piping is allowed in this essential system provided it meets the requirements of category A and other machinery space (See 4-6-3/Table 1)
- In addition to above, an emergency supply of lubricating water is to be provided in case of failure of the primary lubricating system

iii) Lubricant Tank (if applicable)

- Tanks are to be of metallic construction. Alternatively, the designer or builder may use non-metallic construction in accordance with a recognized or international standard acceptable to ABS. Specifications for the tank, including thermal and mechanical properties and chemical and fire resistance, are to be submitted for review.
- Mounting, securing arrangements and electrical bonding arrangements are to be submitted for approval.
- Valves are to be readily accessible and controllable from the floors or gratings. Open or closed indicators are to be provided, see 4-6-2/5.11.3(a). Where the valves are power-operated, the valves are to allow for manual operation in the event of a failure of the power supply.
- Tank Vents and Sounding are to comply with 4-6-4/9 and 4-6-4/11.

iv) Water Filtration System

- The normal operational condition is to be displayed and any failures are to be alarmed as indicated in 4-3-2/Table 5 below.
- Two independent water filtration systems are to be provided to maintain continuous operation of the vessel.
- An auto change-over system is to be provided in case of failure.

15.3.1(d) *Control and Instrument.* Instruments for monitoring the water lubricating stern tube system are to be provided, as indicated in 4-3-2/Table 5 below. All alarms are to be audible and visual and are to be of the self-monitoring type so that a circuit failure will cause an alarm condition. There are to be provisions for testing alarms.

TABLE 5
Instrumentation and Alarm (1 July 2018)

Monitored Parameter	System – Opened Loop (OL) & Closed Loop (CL)	Alarm Condition	Display	Local	Main Control Station ⁽²⁾	Navigation Bridge ^(1, 4)
Flow	OL & CL	Low/High	x	x	x	x
Pressure	OL & CL	Low/High	x	x	x	x
Diff. Pressure (Filter)	OL & CL	High	x	x	x	x
Diff. Pressure (Across S/T)	CL	High	x	x	x	x
Bearing Temperature	OL & CL	High	x	x	x	x
Water Temperature	CL	High	x	x	x	x
Salinity	CL	High	x	x	x	x
Wear Down ⁽³⁾	OL & CL	High	x	x	x	x
Tank Level	CL	Low	x	x	x	x
Water filtration System	OL & CL	Failure	x	x	x	x
Pump	OL & CL	Failure	x	x	x	x
Power Circuit	OL & CL	Failure	x	x	x	x

Notes:

- 1 Either an individual indication or a common trouble alarm may be fitted at this location, provided the individual indication is installed at the equipment (or main control station).
- 2 For vessels not fitted with a main control station, the indication is to be installed at the equipment or other suitable location.
- 3 Where continuous monitoring system is installed.
- 4 Applicable only for **ACCU** Notation.

15.3.1(e) *Lubricant Sampling and Testing.* Sampling and testing procedures are to be available on board as follows:

- A sampling point is to be provided after the water filtration system for periodical testing.
- Suitable test kits are to be provided onboard.
- Testing is to be conducted as per manufacturer’s recommendations.
- For closed loop systems, an additional sampling system is to be provided in the return lubricant line, after bearing lubrication.

15.3.1(f) *Shaft Alignment Calculations.*

- The calculations, alignment procedures, and stern tube inclination details for these shafting arrangements are to comply with 4-3-2/7.3.
- Additionally, the shaft alignment calculations are to be analyzed for both initial conditions and conditions of manufacturer’s maximum allowable wear down limits.
- All calculations and data are to be submitted to and reviewed by ABS.

15.3.1(g) Wear Down.

- A manual gauge (i.e., poker gauge) is to be provided for measuring the bearing wear down.
- The bearing wear down monitoring system may be provided in addition to the manual system to monitor wear down from ship control system.
- The maximum permitted wear down is to be indicated by the manufacturer. (See 7-5-2/1.1 and 7-5-2/1.3 of the *ABS Rules for Survey After Construction (Part 7)*)
- The measurement history is to be recorded and documented on board.

15.3.2 Closed Loop System

15.3.2(a) Anti-freeze Properties. Appropriate anti-freeze properties of lubricant are to be maintained as per manufacturer's recommendation.

15.3.2(b) Contamination. Means are to be provided to detect sea water contamination into the system.

15.3.2(c) Lubricant Quality. Suitable test kits for lubricant quality are to be made available on board.

15.3.2(d) Overpressure Protection. Provisions are to be made for the suitable pressure relief arrangements.

15.3.2(e) Lubricant pH, Cl. The bearing manufacturer is to provide the acceptable limits for pH and Chloride content.

15.3.2(f) Anti-freeze Properties, Temperature Limit. Bearing manufacturer is to provide the anti-freeze properties, temperature limit (lowest & highest) of lubricant water.

15.3.2(g) Shaft Turning System. Propeller shafts are to be equipped with a turning system, providing for rotation.

15.3.3 Opened Loop System

15.3.3(a) Lubricant Source. Primarily, sea water is to be taken from the sea water main/ sea chest. Other sources may be used in case of emergency and where appropriate quality of lubricant is not available when vessel is operating in unclean water.

15.3.3(b) Shaft Turning System. Propeller shafts are to be equipped with a turning system, providing for rotation.

15.5 Management of the Monitored Data

The following management of the monitored data is to be implemented.

15.5.1 Lubricant Sampling (Closed Loop System)

A sample test of lubricant should be carried out at the following intervals:

- i)* Samples are to be analyzed monthly by ship's crew.
- ii)* The documentation on lubricating fresh water analysis is to be available on board, and samples are to be submitted for analysis to a recognized laboratory at least every six (6) months. Analysis to be performed, including the following as a minimum:
 - Material contents as applicable (with the material of the shaft, stern tube and liners used).
 - Corrosion inhibitors in fresh water (pH or equivalent alkalinity indicators) indicating the degree of passivation of the system against corrosion.
 - Salinity indicators or equivalent indicators (i.e., total conductivity).
 - Contents of bearing particles.

15.5.2 Wear Down Measurement

Wear down is to be continuously monitored or measured using manual device at least twice in five years (not to exceed 36 month intervals) and recorded. Records are to be made available to the attending Surveyor.

15.5.3 Bearings Operating Condition

Stern tube bearing temperatures are to be continuously monitored and recorded. Where bearing material properties or bearing arrangements do not require temperature monitoring, consideration may be given by ABS on a case-by-case basis.

15.5.4 Lubricant Operating Condition

Lubricant flow is to be continuously monitored and recorded.

15.5.5 Recording and Analysis

The chief engineer is responsible for recording and maintaining a file of the shipboard-performed lubricant sampling and analysis results, as well as stern tube bearings operating condition. The results of the laboratory analysis are to be stored within the file onboard. All documentation is to be made available to the Surveyor to allow for trend assessment of the measured parameters.

15.7 Test Plan

A Test Plan is to be submitted to ABS to serve as the plan review at the start of the plan review process. The test plan is to identify all equipment and systems and the recommended method of performing the tests or trials.

15.9 Surveys

15.9.1 Bearing and Coating Inspection

- Stern tube bearings are to be examined at installation to the satisfaction of the attending Surveyor.
- The shaft sleeve/liner is to be examined at installation to the satisfaction of the attending Surveyor.
- Where direct access is not available, arrangements are to be made for borescope inspection of the system (e.g., bearing, shaft surface, et al.)
- The inspection procedures for corrosion protection coatings and borescope inspection are to be submitted to ABS.

15.9.2 Initial Survey

All systems in 4-3-2/15 are to be examined and tested to the satisfaction of the attending Surveyor in accordance with the approved plans.

For initial survey of existing vessels, refer to 7-9-20/3.3 of the *ABS Rules for Survey After Construction (Part 7)*.

15.9.3 Survey After Construction

Refer to Section 7-9-20/3 of the *ABS Rules for Survey After Construction (Part 7)*.

PART

4

CHAPTER 3 Propulsion and Maneuvering Machinery

SECTION 2 Appendix 1 – Special Approval of Alloy Steel Used for Intermediate Shaft Material

1 Application

This Appendix is applied to the approval of alloy steel which has a minimum specified tensile strength greater than 800 N/mm² (116030 psi), but less than 950 N/mm² (137786 psi) intended for use as intermediate shaft material.

3 Torsional Fatigue Test

A torsional fatigue test is to be performed to verify that the material exhibits similar fatigue life as conventional steels. The torsional fatigue strength of said material is to be equal to or greater than the permissible torsional vibration stress *S* given by the formula in 4-3-2/Table 4.

The test is to be carried out with notched and un-notched specimens respectively. For calculation of the stress concentration factor of the notched specimen, fatigue strength reduction factor β should be evaluated in consideration of the severest torsional stress concentration in the design criteria.

3.1 Test Conditions

Test conditions are to be in accordance with 4-3-2A1/Table 1. Mean surface roughness is to be < 0.2 μ m Ra with the absence of localized machining marks verified by visual examination at low magnification ($\times 20$) as required by Section 8.4 of ISO 1352.

Test procedures are to be in accordance with Section 10 of ISO 1352.

**TABLE 1
Test Condition**

Loading type	Torsion
Stress ratio	$R = -1$
Load waveform	Constant-amplitude sinusoidal
Evaluation	S-N curve
Number of cycles for test termination	1×10^7 cycles

3.3 Acceptance Criteria

Measured high-cycle torsional fatigue strength τ_{C1} and low-cycle torsional fatigue strength τ_{C2} are to be equal to or greater than the values given by the following formula:

$$\tau_{C1} \geq \tau_{C,\lambda=0} = \frac{\sigma_b + 160}{6} \cdot C_K \cdot C_D$$

$$\tau_{C2} \geq 1.7 \cdot \frac{1}{\sqrt{C_K}} \tau_{C1}$$

where

- C_K = factor for the particular shaft design features, see 4-3-2/Table 4
- scf = stress concentration factor, see 4-3-1A1/9 below (for un-notched specimen, 1.0.)
- C_D = size factor, see 4-3-2/Table 4
- σ_b = specified minimum tensile strength in N/mm² (psi) of the shaft material

5 Cleanliness Requirements

The steels are to have a degree of cleanliness as shown in 4-3-2A1/Table 2 when tested according to ISO 4967 method A. Representative samples are to be obtained from each heat of forged or rolled products.

The steels are generally to comply with the minimum requirements of 4-3-2A1/Table 3, with particular attention given to minimizing the concentrations of sulfur, phosphorus and oxygen in order to achieve the cleanliness requirements. The specific steel composition is required to be approved by the ABS.

TABLE 2
Cleanliness Requirements

<i>Inclusion Group</i>	<i>Series</i>	<i>Limiting Chart Diagram Index I</i>
Type A	Fine	1
	Thick	1
Type B	Fine	1.5
	Thick	1
Type C	Fine	1
	Thick	1
Type D	Fine	1
	Thick	1
Type DS	-	1

TABLE 3
Chemical Composition Limits ⁽¹⁾ for Machinery Steel Forgings

<i>Steel Type</i>	<i>C</i>	<i>Si</i>	<i>Mn</i>	<i>P</i>	<i>S</i>	<i>Cr</i>	<i>Mo</i>	<i>Ni</i>	<i>Cu⁽³⁾</i>	<i>Total Residuals</i>
C,C-Mn	0.65 ⁽²⁾	0.45	0.30-1.50	0.035	0.035	0.30 ⁽³⁾	0.15 ⁽³⁾	0.40 ⁽³⁾	0.30	0.85
Alloy ⁽⁴⁾	0.45	0.45	0.30-1.00	0.035	0.035	Min 0.40 ⁽⁵⁾	Min 0.15 ⁽⁵⁾	Min 0.40 ⁽⁵⁾	0.30	-

Notes:

- 1 Composition in percentage mass by mass maximum unless shown as a range or as a minimum.
- 2 The carbon content of C and C-Mn steel forgings intended for welded construction is to be 0.23 maximum. The carbon content may be increased above this level provided that the carbon equivalent (Ceq) is not more than 0.41%.
- 3 Elements are considered as residual elements unless shown as a minimum.
- 4 Where alloy steel forgings are intended for welded constructions, the proposed chemical composition is subject to approval by the ABS.
- 5 One or more of the elements is to comply with the minimum content.

7 Inspection

Ultrasonic testing is to be carried out prior to acceptance. The acceptance criteria are to be in accordance with a recognized national or international standard.

9 Stress Concentration Factor of Slots

The stress concentration factor (scf) at the end of slots can be determined by means of the following empirical formulae using the symbols in footnote 4 of 4-3-2/Table 1):

$$scf = \alpha_{t(hole)} + 0.8 \cdot \frac{(\ell - e)/d}{\sqrt{\left(1 - \frac{d_i}{d}\right) \cdot \frac{e}{d}}}$$

This formula applies to:

- Slots at 120 or 180 or 360 degrees apart.
- Slots with semicircular ends. A multi-radii slot end can reduce the local stresses, but this is not included in this empirical formula.
- Slots with no edge rounding (except chamfering), as any edge rounding increases the scf slightly.

$\alpha_{t(hole)}$ represents the stress concentration of radial holes (in this context e = hole diameter) and can be determined as:

$$\alpha_{t(hole)} = 2.3 - 3 \cdot \frac{e}{d} + 15 \cdot \left(\frac{e}{d}\right)^2 + 10 \cdot \left(\frac{e}{d}\right)^2 \cdot \left(\frac{d_i}{d}\right)^2$$

or simplified to:

$$\alpha_{t(hole)} = 2.3$$

PART

4

CHAPTER 3 Propulsion and Maneuvering Machinery

SECTION 3 Propellers

1 General

1.1 Application

This section applies to propellers intended for propulsion. It covers fixed pitch and controllable pitch propellers. Propellers for thrusters used for maneuvering and dynamic positioning are covered in Section 4-3-5. Performance of propellers, in respect to developing the designed output, is to be demonstrated during sea trials.

Additional requirements for propellers intended for vessels strengthened for navigation in ice are provided in Part 6.

1.3 Definitions

For purpose of this section, the following definitions apply.

1.3.1 Skew Angle

Skew Angle (θ) of a propeller is the angle measured from ray 'A' passing through the tip of blade at mid-chord line to ray 'B' tangent to the mid-chord line on the projected blade outline. See 4-3-3/Figure 1.

1.3.2 Highly Skewed Propeller

A *Highly Skewed Propeller* is one whose skew angle is more than 25°.

1.3.3 Propeller Rake

1.3.3(a) *Rake*. *Rake* is the distance at the blade tip between the generating line and the line perpendicular to the propeller axis that meets the generating line at the propeller axis. See 4-3-3/Figure 2.

1.3.3(b) *Rake angle (ϕ)*. *Rake Angle* of a propeller is the angle measured from the plane perpendicular to shaft centerline to the tangent to the generating line at a specified radius ($0.6 \times$ radius for the purpose of this section). See 4-3-3/Figure 2.

1.3.4 Wide Tipped Blade Propeller

A propeller blade is to be considered as a wide tipped blade if the maximum expanded blade cord length occurs at or above $0.8R$, with R being the distance measured from the centerline of the propeller hub.

FIGURE 1
Maximum Skew Angle

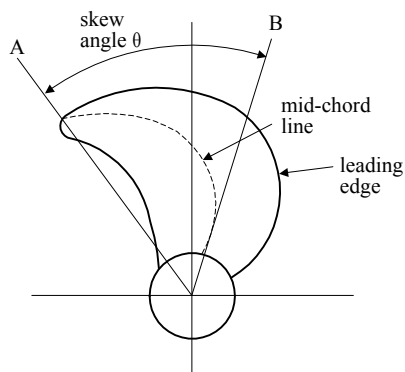
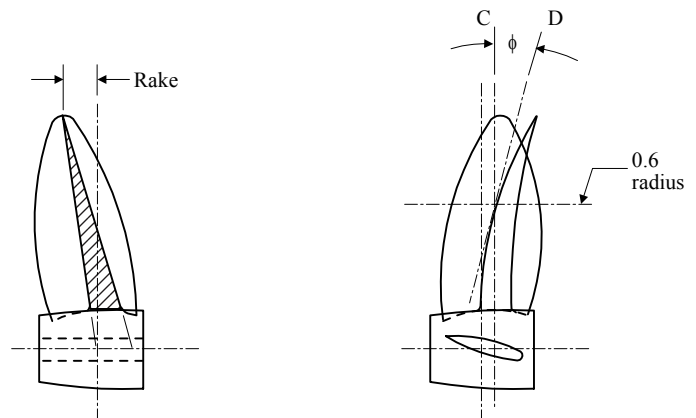

FIGURE 2
Rake and Rake Angle



1.5 Plans and Particulars to be Submitted

1.5.1 Fixed Pitch Propeller of Conventional Design Material

Design characteristics of propeller

Dimensions and tolerances

Propeller plan

Blade thickness calculations

1.5.2 Controllable Pitch Propeller of Conventional Design As per 4-3-3/1.5.1

Hub and hub to tail shaft flange attachment bolts

Propeller blade flange and bolts

Internal mechanism

Hydraulic piping control system

Instrumentation and alarm system

Strength calculations for internal mechanism

1.5.3 Highly Skewed Propeller and Other Unconventional Designs

In addition to the foregoing, where propeller blade designs are of the types for which the Rules do not provide simplified blade thickness calculations, such as

highly skewed propellers with $\theta > 50^\circ$;

high skewed propellers made of other than Type 4 materials with $50^\circ \geq \theta > 25^\circ$;

controllable pitch propellers with $\theta > 25^\circ$;

cycloidal propellers;

propeller load and stress analyses demonstrating adequacy of blade strength are to be submitted.

1.5.4 Keyless Propeller

Where propellers are to be fitted to the shaft without keys, stress calculations for hub stresses and holding capacity, along with fitting instructions, are to be submitted.

3 Materials

3.1 Normally Used Propeller Materials

4-3-3/Table 1 shows the properties of materials normally used for propellers. See 2-3-14/3 and Section 2-3-15 for full details of the materials.

Where an alternative material specification is proposed, detailed chemical composition and mechanical properties are to be submitted for approval (for example, see Section 2-3-14 and Section 2-3-15). The f and w values of such materials to be used in the equations hereunder will be specially considered upon submittal of complete material specifications including corrosion fatigue data to 10^8 cycles.

**TABLE 1
 Propeller Materials**

Type	Material	Tensile strength			Yield strength			Elongation, %	
		N/mm^2	kgf/mm^2	lb/in^2	N/mm^2	kgf/mm^2	lb/in^2	Gauge Length	
							4d	5d	
2	Manganese bronze	450	46	65,000	175	18	25,000	20	18
3	Nickel-manganese bronze	515	53	75,000	220	22.5	32,000	18	16
4	Nickel-aluminum bronze	590	60	86,000	245	25	36,000	16	15
5	Manganese-nickel-aluminum bronze	630	64	91,000	275	28	40,000	20	18
CF-3	Stainless steel	485	49	70,000	205	21	30,000	35	32

3.3 Stud Materials

The material of the studs securing detachable blades to the hub is to be of at least Grade 2 forged steel or equally satisfactory material; see 2-3-7/7 for specifications of Grade 2 forged steel.

3.5 Material Testing

Materials of propellers cast in one piece and materials of blades, hub, studs and other load-bearing parts of controllable pitch propellers are to be tested in the presence of a Surveyor. For requirements of material testing, see 2-3-14/3 and Section 2-3-15 and 2-3-7/7.

5 Design

5.1 Blade Thickness – Fixed Pitch Propeller

Propeller blades of thrusters (as defined in 4-3-5/1.5) and wide-tip blades of ducted propellers are to be in accordance with the provisions of Section 4-3-5. The thickness of the propeller blades of conventional design ($\theta \leq 25^\circ$) is not to be less than that determined by the following equations:

$$t_{0.25} = S \left[K_1 \sqrt{\frac{AH}{C_n CRN}} \pm \left(\frac{C_s}{C_n} \right) \left(\frac{BK}{4C} \right) \right]$$

$$A = 1.0 + \frac{6.0}{P_{0.70}} + 4.3P_{0.25}$$

$$B = \left(\frac{4300wa}{N} \right) \left(\frac{R}{100} \right)^2 \left(\frac{D}{20} \right)^3$$

$$C = (1 + 1.5P_{0.25})(Wf - B)$$

where (units of measures are given in SI (MKS, and US) units respectively):

- a = expanded blade area divided by disc area
- a_s = area of expanded cylindrical section at 0.25 radius; mm² (in²)
- C_n = section modulus coefficient at the 0.25 radius. C_n is to be determined by the following equation:

$$C_n = \frac{I_0}{U_f WT^2}$$

If the calculated C_n value exceeds 0.10, the required thickness is to be computed with $C_n = 0.10$.

- C_s = section area coefficient at 0.25 radius and is to be determined by the following equation:

$$C_s = \frac{a_s}{WT}$$

The values of C_s and C_n , computed as stipulated above, are to be indicated on the propeller drawing. If the C_n value exceeds 0.10, the required thickness is to be computed with $C_n = 0.10$

For vessels below 61 m (200 ft) in length, the required thickness may be computed with the assumed values of $C_n = 0.10$ and $C_s = 0.69$.

- D = propeller diameter; m (ft)
- f, w = material constants from the following table:

Material type (see 4-3-3/3.1)	SI and MKS units		US units	
	f	w	f	w
2	2.10	8.3	68	0.30
3	2.13	8.0	69	0.29
4	2.62	7.5	85	0.27
5	2.37	7.5	77	0.27
CF-3	2.10	7.75	68	0.28

Note:

The f and w values of materials not covered will be specially considered upon submittal of complete material specifications including corrosion fatigue data to 10⁸ cycles.

- H = power at rated speed; kW (PS, hp)
- I_0 = moment of inertia of expanded cylindrical section at 0.25 radius about a straight line through the center of gravity parallel to the pitch line or to the nose-tail line; mm⁴ (in⁴)
- K = rake of propeller blade, in mm (in.) (positive for aft rake and negative for forward rake)
- K_1 = coefficient as given below

	SI	MKS	US
K_1	337	289	13

- N = number of blades
- $P_{0.25}$ = pitch at one-quarter radius divided by propeller diameter, corresponding to the design ahead condition
- $P_{0.70}$ = pitch at seven-tenths radius divided by propeller diameter, corresponding to the design ahead condition

- R = rpm at rated speed
 S = factor, as given below. If greater than 1.025, equate to 1.025.

<i>SI & MKS units</i>	<i>US units</i>
1.0 for $D \leq 6.1$ m	1.0 for $D \leq 20$ ft
$\sqrt{\frac{(D + 24)}{30.1}}$ for $D > 6.1$ m	$\sqrt{\frac{(D + 79)}{99}}$ for $D > 20$ ft

- $t_{0.25}$ = minimum required thickness at the thickest part of the blade section at one quarter radius; mm (in.)
 T = maximum designed thickness of blade section at 0.25 radius from propeller drawing; mm (in.)
 U_f = maximum nominal distance from the moment of inertia axis to points of the face boundary (tension side) of the section; mm (in.)
 W = expanded width of a cylindrical section at 0.25 radius; mm (in.)

5.3 Blade Thickness – Controllable-pitch Propellers

Controllable pitch propeller blades of thrusters (as defined in 4-3-5/1.5) and wide-tip blades of ducted controllable pitch propellers are to be in accordance with the provisions of Section 4-3-5. The thickness of the controllable pitch propeller blade of conventional design ($\theta \leq 25^\circ$) is not to be less than determined by the following equation:

$$t_{0.35} = K_2 \sqrt{\frac{AH}{C_n CRN}} \pm \left(\frac{C_s}{C_n} \right) \left(\frac{BK}{6.3C} \right)$$

$$A = 1.0 + \frac{6.0}{P_{0.70}} + 3P_{0.35}$$

$$B = \left(\frac{4900wa}{N} \right) \left(\frac{R}{100} \right)^2 \left(\frac{D}{20} \right)^3$$

$$C = (1 + 0.6P_{0.35})(Wf - B)$$

where the symbols used in these formulas are the same as those in 4-3-3/5.1, except as modified below:

- a_s = area of expanded cylindrical section at 0.35 radius; mm² (in²)
 C_n = section modulus coefficient at the 0.35 radius and is to be determined by the following equation:

$$C_n = \frac{I_0}{U_f WT^2}$$

If the calculated C_n value exceeds 0.10, the required thickness is to be computed with $C_n = 0.10$.

- C_s = section area coefficient at 0.35 radius and is to be determined by the following equation:

$$C_s = \frac{a_s}{WT}$$

The values of C_s and C_n , computed as stipulated above, are to be indicated on the propeller drawing. If the C_n value exceeds 0.10, the required thickness is to be computed with $C_n = 0.10$

For vessels below 61 m (200 ft) in length, the required thickness may be computed with the assumed values of $C_n = 0.10$ and $C_s = 0.69$.

I_0 = moment of inertia of expanded cylindrical section at 0.35 radius about a straight line through the center of gravity parallel to the pitch line or to the nose-tail line; mm⁴ (in⁴)

K_2 = coefficient as given below

	SI	MKS	US
K_2	271	232	10.4

$P_{0.35}$ = pitch at 0.35 radius divided by D

T = maximum designed thickness of blade section at 0.35 radius from propeller drawing; mm (in.)

$t_{0.35}$ = required minimum thickness of the thickest part of the blade section at 0.35 radius; mm (in.)

W = expanded width of a cylindrical section at 0.35 radius; mm (in.)

5.5 Blade Thickness – Highly Skewed Fixed-pitch Propellers

5.5.1 Propeller Blades with Skew Angle θ ; where $25^\circ < \theta \leq 50^\circ$

The provisions of 4-3-3/5.5.1 are applicable to fixed pitch propellers having a skew angle over 25° but not exceeding 50° , and made of Type 4 material only. For propellers of other materials, see 4-3-3/5.5.2. Where the skew angle is greater than 50° , see 4-3-3/5.5.3.

5.5.1(a) *Blade thickness at 0.25 radius.* The maximum thickness at 0.25 radius is to be not less than the thickness required in 4-3-3/5.1 for fixed pitch-propellers multiplied by the factor m as given below:

$$m = \sqrt{1 + 0.0065(\theta - 25)}$$

5.5.1(b) *Blade thickness at 0.6 radius.* The maximum thickness of the blade section at 0.6 radius is to be not less than that obtained from the following equations:

$$t_{0.6} = K_3 \cdot \sqrt{\left(1 + C_{0.9}\right) \left(1 + \frac{2C_{0.9}}{C_{0.6}}\right) \left(\frac{HD\Gamma}{RP_{0.6}Y}\right)^{0.5}}$$

$$\Gamma = \left(1 + \frac{\theta - 25}{\theta}\right) (\phi^2 + 0.16\phi \cdot \theta \cdot P_{0.9} + 100)$$

where

$C_{0.6}$ = expanded chord length at the 0.6 radius divided by propeller diameter

$C_{0.9}$ = expanded chord length at the 0.9 radius divided by propeller diameter

K_3 = coefficient as given below:

	SI	MKS	US
K_3	12.6	6.58	1.19

$P_{0.6}$ = pitch at the 0.6 radius divided by propeller diameter

$P_{0.9}$ = pitch at the 0.9 radius divided by propeller diameter

$t_{0.6}$ = required thickness of the blade section at 0.6 radius; mm (in.)

Y = minimum specified yield strength of type 4 propeller material; N/mm² (kgf/mm², psi). See 4-3-3/Table 1.

θ = skew angle in degrees (see 4-3-3/1.3.1)

ϕ = rake angle in degrees [see 4-3-3/1.3.3(b)] at 0.6 radius, positive for aft rake

H , D , and R are as defined in 4-3-3/5.1.

5.5.1(c) *Blade thickness between 0.6 and 0.9 radii.* The maximum thickness at any radius between 0.6 and 0.9 radii is to be not less than that obtained from the following equation:

$$t_x = 3.3D + 2.5(1 - x)(t_{0.6} - 3.3D) \quad \text{mm; or}$$

$$t_x = 0.04D + 2.5(1 - x)(t_{0.6} - 0.04D) \quad \text{in.}$$

where:

t_x = required minimum thickness of the thickest part of the blade section at radius ratio x .

$t_{0.6}$ = thickness of blade section at the 0.6 radius, as required by 4-3-3/5.5.1(b)

x = ratio of the radius under consideration to $D/2$; $0.6 < x \leq 0.9$

5.5.1(d) *Trailing edge thickness at 0.9 radius.* The edge thickness at 0.9 radius measured at 5% of chord length from the trailing edge is to be not less than 30% of the maximum blade thickness required by 4-3-3/5.5.1(c) above at that radius.

5.5.2 Propeller of Other Than Type 4 Materials with Skew Angle θ ; where $25^\circ < \theta \leq 50^\circ$

Propellers made of materials other than Type 4 and with skew angle $25^\circ < \theta \leq 50^\circ$ are subject to special consideration. Design analyses, as indicated in 4-3-3/5.7, are to be submitted.

5.5.3 Propeller Blades with Skew Angle $\theta > 50^\circ$

Propellers with the maximum skew angle exceeding 50° will be subject to special consideration. Design analyses, as indicated in 4-3-3/5.7, are to be submitted.

5.7 Blades of Unusual Design

Propellers of unusual design, such as those indicated in 4-3-3/5.5.2 and 4-3-3/5.5.3, controllable pitch propeller of skewed design ($\theta > 25^\circ$), skewed propeller ($\theta > 25^\circ$) with wide-tip blades, cycloidal propellers, etc., are subject to special consideration based on submittal of propeller load and stress analyses. The analyses are to include, but be not limited to the following:

- Description of method to determine blade loading
- Description of method selected for stress analysis
- Ahead condition is to be based on propulsion machinery's maximum rating and full ahead speed
- Astern condition is to be based on the maximum available astern power of the propulsion machinery (the astern power of the main propelling machinery is to be capable of 70% of the ahead rpm corresponding to the maximum continuous ahead power, as required in 4-1-1/7.5); and is to include crash astern operation
- Fatigue assessment
- Allowable stress and fatigue criteria

5.9 Blade-root Fillets

Fillets at the root of the blades are not to be considered in the determination of blade thickness.

5.10 Built-up Blades

The required blade section is not to be reduced in order to provide clearance for nuts. The face of the flange is to bear on that of the hub in all cases, but the clearance of the spigot in its counterbore or the edge of the flange in the recess is to be kept to a minimum.

5.11 Strengthening for Navigation in Ice

For vessels to be assigned with **Ice Class** notations, propellers are to be designed in accordance with Section 6-1-3, 6-1-5/51 or 6-1-6/27.

5.13 Controllable Pitch Propellers – Pitch Actuation System

5.13.1 Blade Flange and Mechanisms

The strength of the propeller blade flange and pitch changing mechanism of controllable-pitch propellers subjected to the forces from propulsion torque is to be at least 1.5 times that of the blade at design pitch conditions.

5.13.2 Stud Bolt Area

The sectional area of the stud bolts at the bottom of the thread, s , is to be determined by the following equations:

	<i>SI units</i>	<i>MKS units</i>	<i>US units</i>
s	$\frac{0.056Wkft_{0.35}^2}{n} \text{ mm}^2$		$\frac{0.0018Wkft_{0.35}^2}{n} \text{ in}^2$
k	$\frac{621}{U + 207}$	$\frac{63.3}{U + 21.1}$	$\frac{90,000}{U + 30,000}$

where

- s = area of one stud at bottom of thread
- n = number of studs on driving side of blade
- r = radius of pitch circle of the studs; mm (in.)
- k = material correction factor for stud materials better than ABS Gr. 2 forged steel
- U = ultimate tensile strength of the stud material; N/mm² (kgf/mm², psi)

See 4-3-3/5.1 for f and 4-3-3/5.3 for W and $t_{0.35}$.

5.13.3 Blade Pitch Control

5.13.3(a) Bridge control. Where the navigation bridge is provided with direct control of propulsion machinery, it is to be fitted with means to control the pitch of the propeller.

5.13.3(b) Duplication of power unit. At least two hydraulic power pump units for the pitch actuating system are to be provided and arranged so that the transfer between pump units can be readily effected. For propulsion machinery spaces intended for unattended operation (**ACCU** or **ABCU** notation), automatic start of the standby pump unit is to be provided.

The emergency pitch actuating system [as required by 4-3-3/5.13.3(c)iii] may be accepted as one of the required hydraulic power pump units, provided it is no less effective.

5.13.3(c) Emergency provisions. To safeguard the propulsion and maneuvering capability of the vessel in the event of any single failure in either the remote pitch control system or the pitch actuating system external to the propeller shaft and oil transfer device (also known as oil distribution box), the following are to be provided:

- i)* Manual control of pitch at or near the pitch-actuating control valve (usually the directional valve or similar).
- ii)* The pitch is to remain in the last ordered position until the emergency pitch actuating system is brought into operation.
- iii)* An emergency pitch actuating system. This system is to be independent of the normal system up to the oil transfer device, provided with its own oil reservoir and able to change the pitch from full ahead to full astern.
- iv)* Where at least two (2) independent propulsion systems are fitted on the vessel each one provided with its own pitch control system, and with one propulsion system temporarily out of service (until the emergency pitch control is connected), the vessel can manoeuvre and maintain a speed of 7 knots or one-half of the design speed whichever is the lesser, the requirements as per 4-3-3/5.13.3(c)iii need not be applied, provided the system details are clearly indicated in the operating manuals.

5.13.3(d) *Integral oil systems.* Where the pitch actuating hydraulic system is integral with the reduction gear lubricating oil system and/or clutch hydraulic system, the piping is to be arranged such that any failure in the pitch actuating system will not leave the other system(s) non-operational.

5.13.3(e) *Provisions for testing.* Means are to be provided in the pitch actuating system to simulate system behavior in the event of loss of system pressure. Hydraulic pump units driven by main propulsion machinery are to be fitted with a suitable by-pass for this purpose.

5.13.3(f) *Multiple propellers.* For vessels fitted with more than one controllable pitch propeller, each of which is independent of the other, only one emergency pitch actuating system [as required by 4-3-3/5.13.3(c)iii)] need be fitted, provided it is arranged such that it can be used to provide emergency pitch-changing for all propellers.

5.13.3(g) *Hydraulic piping.* Hydraulic piping is to meet the requirements of 4-6-7/3.

5.13.4 Instrumentation

All controllable pitch propeller systems are to be provided with instrumentation as provided below:

5.13.4(a) *Pitch indicators.* A pitch indicator is to be fitted on the navigation bridge. In addition, each station capable of controlling the propeller pitch is to be fitted with a pitch indicator.

5.13.4(b) *Monitoring.* Individual visual and audible alarms are to be provided at the engine room control station to indicate hydraulic oil low pressure and high temperature and hydraulic tank low level. A high hydraulic oil pressure alarm is to be fitted, if required by the proposed system design and, if fitted, is to be set below the relief valve setting.

For vessels assigned with **ACC** or **ACCU** notations, see 4-9-2/Table 2 and 4-9-5/Table 1 for monitoring on the navigation bridge and in the centralized control station, respectively.

5.15 Propeller Fitting

5.15.1 Keyed Fitting

For shape of the keyway in the shaft and size of the key, see 4-3-2/5.7, 4-3-2/Figure 2 and 4-3-2/5.11.

5.15.2 Keyless Fitting

5.15.2(a) *Design criteria.* The factor of safety against slip of the propeller hub on the tail shaft taper at 35°C (95°F) is to be at least 2.8 under the action of maximum continuous ahead rated torque plus torque due to torsional vibrations. See 6-1-5/51.7 for propellers requiring ice strengthening. For oil injection method of fit, the coefficient of friction is to be taken no greater than 0.13 for bronze/steel propeller hubs on steel shafts. The maximum equivalent uniaxial stress (von Mises-Hencky criteria) in the hub at 0°C (32°F) is not to exceed 70% of the minimum specified yield stress or 0.2% proof stress of the propeller material.

Stress calculations and fitting instructions are to be submitted (see 4-3-3/1.5.4) and are to include at least the following:

- Theoretical contact surface area
- The maximum permissible pull-up length at 0°C (32°F) as limited by the maximum permissible uniaxial stress specified above
- The minimum pull-up length and contact pressure at 35°C (95°F) to attain a safety factor against slip of 2.8
- The proposed pull-up length and contact pressure at fitting temperature
- The rated propeller ahead thrust

5.15.2(b) *Nomenclature.* The symbols used are defined as follows.

- A = 100% of contact surface area between propeller hub and shaft taper (i.e., $A = \pi D_s L$); mm² (in²). Oil grooves may be ignored. The propeller hub forward and aft counterbore lengths (ℓ_1 and ℓ_2 in 4-3-3/Figure 3) and the forward and aft inner edge radii (r_1 and r_2 in 4-3-3/Figure 3), if any, are to be excluded.
- B = dimensionless constant based on μ , θ and S
- c = coefficient, dependent on the type of propulsion drive: 1.0 for drives such as turbine, geared diesel, electric, and direct diesel with elastic coupling; and 1.2 for direct diesel drive. This value may have to be increased for cases where extremely high pulsating torque is expected in service.
- D_b = mean outer diameter of propeller hub corresponding to D_s ; mm (in.) D_b is to be calculated as the mean of D_{bm} , D_{bf} and D_{ba} , outer diameters of hub corresponding to D_s , the forward point of contact and the aft point of contact, respectively, see 4-3-3/Figure 3.
- $$D_b = \frac{D_{ba} + D_{bm} + D_{bf}}{3}$$
- D_{bm} = mean outer diameter of propeller boss, in mm (in.), at the axial position corresponding to D_s , see 4-3-3/Figure 3.
- D_s = diameter of shaft at mid-point of the taper in axial direction; mm (in.), taking into account the exclusion of forward and aft counterbore length and the forward and aft edge radii, see 4-3-3/Figure 3.

FIGURE 3
Theoretical Contact Surface Between Hub and Shaft

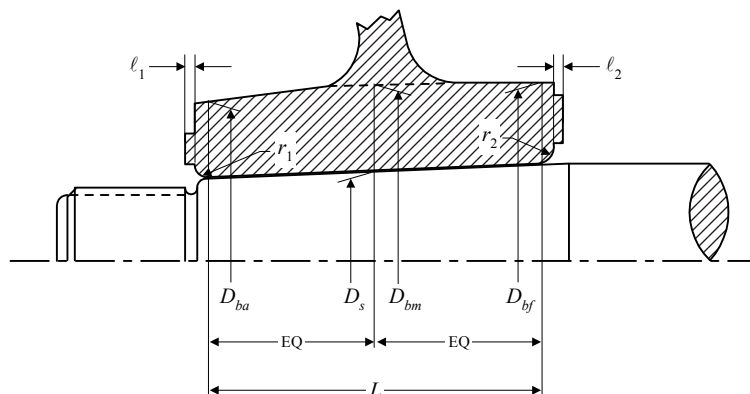

- E_b = modulus of elasticity of hub material, see 4-3-3/Table 2
- E_s = modulus of elasticity of shaft material, see 4-3-3/Table 2
- F_v = shear force at propeller/shaft interface; N (kgf, lbf)
- H = power at rated speed; kW (PS, hp)
- K = ratio of D_b to D_s , see 4-3-3/Figure 3.
- L = contact length, in mm (in.), see 4-3-3/Figure 3
- P = mean propeller pitch; mm, (in.)

- P_{\min} = minimum required mating surface pressure at 35°C (95°F); N/mm² (kgf/mm², psi)
- P_t = minimum required mating surface pressure at temperature t ; N/mm² (kgf/mm², psi)
- P_{\max} = maximum permissible mating surface pressure at 0°C; N/mm² (kgf/mm², psi)
- Q = rated torque corresponding to H and R ; N-mm (kgf-mm, lbf-in)
- R = rpm at rated speed
- S = factor of safety against slippage at 35°C (95vF)
- T = rated propeller thrust; N (kgf, lbf)
- t_{ref} = 35°C (95°F)
- v = vessel speed at rated power; knots (knots)
- α_b = coefficient of linear expansion of propeller hub material; mm/mm°C (in/in°F); see 4-3-3/Table 2
- α_s = coefficient of linear expansion of shaft material; mm/mm°C (in/in°F); see 4-3-3/Table 2
- δ_{\min} = minimum pull-up length at 35°C (95°F); mm (in.)
- δ_t = minimum pull-up length at temperature t ; mm (in.)
- δ_{\max} = maximum permissible pull-up length at 0°C (32°F); mm (in.)
- θ = half taper of shaft; e.g. if taper = 1/15, $\theta = 1/30$
- σ_y = yield stress or 0.2% proof stress of propeller material; N/mm² (kgf/mm², psi)
- μ = coefficient of friction between mating surfaces; to be taken as 0.13 for fitting methods using oil injection and hubs of bronze or steel
- ν_b = Poisson's ration of hub material, see 4-3-3/Table 2
- ν_s = Poisson's ratio of shaft material, see 4-3-3/Table 2

TABLE 2
Material Constants

Material	Modulus of Elasticity			Poisson's Ratio	Coefficient of Expansion	
	N/mm ²	kgf/mm ²	psi		mm/mm°C	in/in°F
Cast and forged steel	20.6 × 10 ⁴	2.1 × 10 ⁴	29.8 × 10 ⁶	0.29	12.0 × 10 ⁻⁶	6.67 × 10 ⁻⁶
Bronzes, Types 2 & 3	10.8 × 10 ⁴	1.1 × 10 ⁴	15.6 × 10 ⁶	0.33	17.5 × 10 ⁻⁶	9.72 × 10 ⁻⁶
Bronzes, Types 4 & 5	11.8 × 10 ⁴	1.2 × 10 ⁴	17.1 × 10 ⁶	0.33	17.5 × 10 ⁻⁶	9.72 × 10 ⁻⁶

5.15.2(c) Equations. The taper on the tail shaft cone is not to exceed 1/15. Although the equations given below are for ahead operation, they may be considered to provide an adequate safety margin for astern operation also.

The minimum mating surface pressure at 35°C (95°F), P_{\min} , is to be:

$$P_{\min} = \frac{ST}{AB} \left[-S\theta + \sqrt{\mu^2 + B \left(\frac{F_v}{T} \right)^2} \right] \text{ N/mm}^2 \text{ (kgf/mm}^2, \text{ psi)}$$

The rated propeller thrust, T , submitted by the designer is to be used in these calculations. In the event that this is not submitted, one of the equations in 4-3-3/Table 3 may be used, subject to whichever yields the larger value of P_{\min} .

TABLE 3
Estimated Propeller Thrust, T

<i>SI units (N)</i>	<i>MKS units (kgf)</i>	<i>US units (lbf)</i>
$1762 \frac{H}{v}$ or $57.4 \times 10^6 \cdot \frac{H}{PR}$	$132 \frac{H}{v}$ or $4.3 \times 10^6 \cdot \frac{H}{PR}$	$295 \frac{H}{v}$ or $0.38 \times 10^6 \cdot \frac{H}{PR}$

The shear force at interface, F_v , is given by

$$F_v = \frac{2cQ}{D_s} \quad \text{N (kgf, lbf);}$$

Constant B is given by:

$$B = \mu^2 - S^2\theta^2$$

The corresponding [i.e., at 35°C (95°F)] minimum pull-up length, δ_{\min} , is:

$$\delta_{\min} = P_{\min} \frac{D_s}{2\theta} \left[\frac{1}{E_b} \left(\frac{K^2 + 1}{K^2 - 1} + \nu_b \right) + \frac{1}{E_s} (1 - \nu_s) \right] \quad \text{mm (in.);}$$

$$K = \frac{D_b}{D_s}$$

The minimum pull-up length, δ_t , at temperature, t , where $t < 35^\circ\text{C}$ (95°F), is:

$$\delta_t = \delta_{\min} + \frac{D_s}{2\theta} (\alpha_b - \alpha_s)(t_{ref} - t) \quad \text{mm (in.)}$$

The corresponding minimum surface pressure, P_t , is:

$$P_t = P_{\min} \frac{\delta_t}{\delta_{\min}} \quad \text{N/mm}^2 \text{ (kgf/mm}^2, \text{ psi)}$$

The maximum permissible mating surface pressure, P_{\max} , at 0°C (32°F) is:

$$P_{\max} = \frac{0.7\sigma_y(K^2 - 1)}{\sqrt{3K^4 + 1}} \quad \text{N/mm}^2 \text{ (kgf/mm}^2, \text{ psi)}$$

and the corresponding maximum permissible pull-up length, δ_{\max} , is:

$$\delta_{\max} = \frac{P_{\max}}{P_{\min}} \delta_{\min} \quad \text{mm (in.)}$$

7 Certification

7.1 Material Tests

Propeller materials are to be tested in the presence of a Surveyor. See 4-3-3/3.5.

7.3 Inspection and Certification

Finished propellers are to be inspected and certified at the manufacturer's plant by a Surveyor. The blade forms, pitch, blade thickness, diameters, etc. are to be checked for conformance with approved plans. The entire surface of the finished propeller is to be examined visually and by liquid penetrant method. See 2-3-14/3.21 of the *ABS Rules for Materials and Welding (Part 2)*. All finished propellers are to be statically balanced in the presence of the Surveyor. As far as practicable, reference is to be made to the provisions of ISO 484 for these purposes.

The surfaces of stainless steel propellers are to be suitably protected from the corrosive effect of the industrial environment until fitted on the vessel. See 2-3-15/3 of the *ABS Rules for Materials and Welding (Part 2)*.

9 Installation, Tests and Trial

9.1 Keyed Propellers

The sides of the key are to have a true fit in the keyways of the propeller hub and the shaft. See also 4-3-2/5.11 for tail shaft propeller-end design.

9.3 Controllable Pitch Propellers – Fit of Studs and Nuts

Studs, nuts and bolts are to have tight-fitting threads and are to be provided with effective means of locking. Effective sealing arrangements are to be provided in way of the bolt or stud holes against sea water ingress or oil leakage. Bolts, nuts and studs are to be of corrosion resistant materials or adequately protected from corrosion.

9.5 Protection Against Corrosion

The exposed steel of the shaft is to be protected from the action of the water by filling all spaces between cap, hub and shaft with a suitable material. The propeller assembly is to be sealed at the forward end with a well-fitted soft-rubber packing ring. When the rubber ring is fitted in an external gland, the hub counterbore is to be filled with suitable material, and clearances between shaft liner and hub counterbore are to be kept to a minimum. When the rubber ring is fitted internally, ample clearance is to be provided between liner and hub. The rubber ring is to be sufficiently oversized to squeeze into the clearance space provided; and, where necessary, a filler piece is to be fitted in way of the propeller-hub keyway to provide a flat, unbroken seating for the rubber ring. The recess formed at the small end of the taper by the overhanging propeller hub is also to be packed with rust-preventive compound. See 4-3-2/5.13 for sealing requirements and 4-3-2/Figure 2 for typical arrangements.

9.6 Noncorrosive, Non-pitting Alloys

The sealing arrangements above are not required where the tail shaft is fabricated of corrosion-resistant, pitting-resistant alloy unless required by the manufacturer.

9.7 Circulating Currents

Where means are provided to prevent circulating currents from passing between the propeller, shaft and the hull, a warning notice plate is to be provided in a visible place cautioning against the removal of such protection.

9.9 Keyed and Keyless propellers – Contact Area Check and Securing

The propeller hub to tail shaft taper contact area is to be checked in the presence of a Surveyor. In general, the actual contact area is to be not less than 70% of the theoretical contact area. Non-contact bands extending circumferentially around the propeller hub or over the full length of the hub are not acceptable. Installation is to be in accordance with the procedure referred to in 4-3-3/5.15.2(a) and final pull-up travel is to be recorded. After final pull-up, propellers are to be secured by a nut on the after end of the tail shaft. The nut is to be secured to the tail shaft against loosening. See also 4-3-2/5.11.

9.11 Controllable Pitch Propellers – Hydrostatic Tests

The completed piping system of the controllable pitch propeller hydraulic system is to be hydrostatically tested at a pressure equal to 1.5 times the design pressure in the presence of a Surveyor. Relief-valve operation is to be verified.

9.13 Sea Trial

The designed performance of the propeller at rated speed is to be demonstrated during sea trial. For controllable pitch propellers, the blade pitch control functions, from full ahead through full astern, are to be demonstrated. The emergency provisions in 4-3-3/5.13.3(c) are also to be demonstrated.

PART

4

CHAPTER 3 Propulsion and Maneuvering Machinery

SECTION 4 Steering Gears

1 General

1.1 Application

This Section is applicable to vessels for which steering is effected by means of a rudder or rudders and an electric, hydraulic or electro-hydraulic steering gear.

Additional requirements for azimuthal thrusters are given in 4-3-5/5.11.

Steering gears intended for vessels strengthened for navigation in ice are to comply also with additional requirements in Part 6.

For convenience, additional requirements specific to passenger vessels and to vessels intended to carry oil, chemical or liquefied gases in bulk are provided in 4-3-4/23 and 4-3-4/25 hereunder.

1.3 Basic Principles

All vessels are to be provided with power-operated means of steering. Such means, as a minimum, are to be supported by duplication of power units, and by redundancy in piping, electrical power supply, and control circuitry. Steering is to be capable of being readily regained in the event of the failure of a power unit, a piping component, a power supply circuit or a control circuit. In addition, duplication of rudder actuators is to be provided for oil and fuel oil carriers, chemical carriers and gas carriers in accordance with the requirements in 4-3-4/5.3 and 4-3-4/25, as applicable.

1.5 Definitions

For the purpose of this section the following definitions apply:

1.5.1 Steering Gear

Steering Gear is the machinery, rudder actuators, steering gear power units and ancillary equipment and the means of applying torque to the rudder stock (e.g., tiller or quadrant) necessary for effecting movement of the rudder for the purpose of steering the vessel under normal service conditions.

1.5.1(a) Main Steering Gear. Main steering gear is the machinery, rudder actuators, power units, ancillary equipment and the means of applying torque to the rudder stock (e.g., tiller or quadrant) necessary for effecting movement of the rudder for the purpose of steering the vessel.

1.5.1(b) Auxiliary Steering Gear. Auxiliary steering gear is the equipment other than any part of the main steering gear necessary to steer the vessel in the event of failure of the main steering gear, but not including the tiller, quadrant or components serving the same purpose.

1.5.2 Steering Gear Power Unit

Steering Gear Power Unit is:

- i) In the case of electro-hydraulic steering gears, an electric motor and its associated electrical equipment and connected pump.
- ii) In the case of other hydraulic steering gears, a driving engine and connected pump.
- iii) In the case of electric steering gears, an electric motor and its associated electrical equipment.

1.5.3 Power Actuating System

Power Actuating System of hydraulic and electro-hydraulic steering gears is the hydraulic equipment provided for supplying power to turn the rudder stock, comprising a steering gear power unit or units, together with the associated pipes and fittings and a rudder actuator. Where duplicated power actuating systems are required by the Rules, they may share common mechanical components, i.e., tiller, quadrant and rudder stock, or components serving the same purpose.

1.5.4 Rudder Actuator

Rudder Actuator is the component which directly converts hydraulic pressure into mechanical action to move the rudder. This may be a hydraulic cylinder or a hydraulic motor.

1.5.5 Maximum Working Pressure

Maximum Working Pressure is the pressure needed to satisfy the operational conditions specified in 4-3-4/1.9.

1.5.6 Steering Gear Control System

Steering Gear Control System is the equipment by which orders are transmitted from the navigation bridge to the steering gear power actuating system. Steering gear control systems comprise transmitters, receivers, hydraulic control pumps and their associated motors, motor controllers, piping and cables required to control the steering gear power actuating system. For the purpose of the Rules, steering wheels, steering levers, and rudder angle feedback linkages are not considered to be part of the control system.

1.5.7 Maximum Ahead Service Speed

Maximum Ahead Service Speed is the greatest speed which the vessel is designed to maintain in service at sea at the deepest seagoing draft.

1.5.8 Rule Required Upper Rudder Stock Diameter

The *Rule Required Upper Rudder Stock Diameter* is the rudder stock diameter in way of the tiller, calculated as given in 3-2-14/7.1. This required diameter excludes strengthening for navigation in ice.

1.7 Steering Gear Compartment

The steering gear is to be protected from the weather. Steering gear compartments are to be readily accessible and, as far as practicable, separated from the machinery spaces. Working access is to be provided to the steering gear machinery and controls with handrails, gratings or other non-slip surfaces to ensure suitable working conditions in the event of hydraulic fluid leakage.

In the event of control system failure, or the need to operate the main or the auxiliary steering gear from within the steering compartment or from positions other than the navigation bridge, vessels of 500 gross tons and above are to be provided with means to indicate the position of the rudder at these positions where emergency steering is to be conducted.

Steering gear compartments in vessels of 500 gross tons and above are to be provided with visual compass readings.

1.9 Performance

1.9.1 Main Steering Gear Capability

- i) Putting the rudder from 35° on one side to 35° on the other side with the vessel running ahead at the maximum continuous rated shaft rpm and at the summer load waterline and, under the same conditions, from 35° on either side to 30° on the other side in not more than 28 seconds; and
- ii) With one of the power units inoperative, putting the rudder from 15° on one side to 15° on the other side in no more than 60 seconds with the vessel running ahead at the summer load waterline at one half of the maximum ahead service speed or 7 knots, whichever is the greater.

1.9.2 Auxiliary Steering Gear Capability

- i) The auxiliary steering gear, when it is not integral with the main steering gear, is to be capable of putting the rudder from 15° on one side to 15° on the other side in not more than 60 seconds with the vessel running ahead at half speed, or seven knots, whichever is greater.
- ii) The auxiliary steering gear is to be so arranged that the failure of the main steering gear will not render it inoperative. Likewise, failure of the auxiliary steering gear is not to affect the main steering gear.
- iii) An auxiliary steering gear is not required when the main steering gear comprises two or more power units, and is so arranged that after a single failure in its piping system or in one of the power units, the defect can be isolated so that the steering capability can be maintained or regained; and provided that the main steering gear is to be capable of operating the rudder, as required by 4-3-4/1.9.1i), while all the power units are in operation.

1.9.3 Passenger Vessels Steering Gear

For passenger vessels, see 4-3-4/23.

1.11 Plans and Particulars to be Submitted

The following plans and particulars are to be submitted for review:

- Arrangement of steering gear machinery
- Hydraulic piping system diagram
- Power supply system diagrams
- Motor control system diagrams
- Steering control system diagrams including automatic isolating system in 4-3-4/25.1.2ii)
- Instrumentation and alarm system diagrams
- Drawings and details for rudder actuators
- Drawings and details for torque transmitting parts and parts subjected to internal hydraulic pressure
- Weld details and welding procedure specifications
- Rated torque

3 Materials

3.1 General

All parts of the steering gear transmitting forces to the rudder and pressure retaining components of hydraulic rudder actuators are to be of steel or other approved ductile material. In general materials are not to have a tensile strength in excess of 650 N/mm² (66 kgf/mm², 94,300 psi).

Gray cast iron or other material having an elongation ($L_0/d = 4$) less than 12% in 50 mm (2 in.) is not to be used for these parts.

3.3 Material Testing

Except as modified below, materials for the parts and components mentioned in 4-3-4/3.1 are to be tested in the presence of the Surveyor in accordance with the requirements of Part 2, Chapter 3 or such other appropriate material specifications as may be approved in connection with a particular design.

3.3.1 Coupling Bolts and Keys

Material tests for steering gear coupling bolts and torque transmitting keys need not be witnessed by the Surveyor, but manufacturer's test certificates traceable to these components are to be presented upon request.

3.3.2 Small Parts of Rudder Actuators

Material tests for forged, welded or seamless steel parts (including the internal components) of rudder actuators that are under 150 mm (6 in.) in internal diameter need not be carried out in the presence of the Surveyor. Such parts may be accepted on the basis of a review of mill certificates by the Surveyor.

3.3.3 Tie Rod Nuts

Material tests for commercially supplied tie-rod nuts need not be witnessed by the Surveyor provided the nuts are in compliance with the approved steering gear drawings and are appropriately marked and identified in accordance with a recognized industry standard. Mill test reports for the tie-rod nuts are to be made available to the Surveyor upon request. For all non-standard tie-rod nuts, material testing is required to be performed in the presence of the Surveyor.

3.3.4 Piping Material

Piping materials need not be tested in the presence of the Surveyor. Pipes may be accepted based on certification by the mill, and on physical inspection and review of mill certificate by the Surveyor.

5 System Arrangements

5.1 Power Units

The steering gear is to be composed of two or more identical power units and is to be capable of operating the rudder as required by 4-3-4/1.9i) and 4-3-4/1.9ii). The power units are to be served by at least two power circuits (see 4-3-4/11). Power units are required to be type tested, see 4-3-4/19.5.

5.3 Rudder Actuators

Steering gears may be composed of a single rudder actuator for all vessels except the following:

- For oil carriers, fuel oil carriers, chemical carriers and gas carriers of 100,000 tonnes deadweight and above, the steering gear is to be comprised of two or more identical rudder actuators.
- For oil carriers, fuel oil carriers, chemical carriers and gas carriers of 10,000 gross tonnage and above but less than 100,000 tonnes deadweight, the steering gear may be comprised of a single, non-duplicated rudder actuator, provided it complies with 4-3-4/25.5.

5.5 Single Failure Criterion

The hydraulic system is to be designed so that after a single failure in the piping system or one of the power units, the defect can be isolated so that the integrity of the remaining part of the system will not be impaired and the steering capability can be maintained or speedily regained. See also 4-3-4/9.

5.7 Independent Control Systems

Two independent steering gear control systems are to be provided, each of which can be operated from the navigation bridge. These control systems are to allow rapid transfer of steering power units and of control between the units. See 4-3-4/13.

5.9 Non-duplicated Components

Essential components which are not required to be duplicated are to utilize, where appropriate, anti-friction bearings, such as ball bearings, roller bearings or sleeve bearings which are to be permanently lubricated or provided with lubrication fittings.

5.11 Power Gear Stops

The steering gear is to be fitted with arrangements, such as limit switches, for stopping the gear before the structural rudder stops (see 3-2-14/1.7) or positive mechanical stops within the steering gear are reached. These arrangements are to be synchronized with the rudder stock or the position of the gear itself and may be an integral part of the rudder actuator. Arrangements to satisfy this requirement through the steering gear control system are not permitted.

5.13 Steering Gear Torques

5.13.1 Minimum Required Rated Torque

The rated torque of the steering gear is not to be less than the expected torque, as defined in 3-2-14/1.5.

5.13.2 Maximum Allowable Torque

The transmitted torque, T_{\max} , of the steering gear is not to be greater than the maximum allowable torque, T_{ar} , based on the actual rudder stock diameter.

5.13.2(a) *Transmitted torque.* The transmitted torque, T_{\max} , is to be based on the relief valve setting and to be determined in accordance with the following equations:

- For ram type actuator:

$$T_{\max} = P \cdot N \cdot A \cdot L_2 / (C \cdot \cos^2 \theta) \quad \text{kN-m (tf-m, Ltf-ft)}$$

- For rotary vane type actuator:

$$T_{\max} = P \cdot N \cdot A \cdot L_2 / C \quad \text{kN-m (tf-m, Ltf-ft)}$$

- For linked cylinder type actuator:

$$T_{\max} = P \cdot N \cdot A \cdot L_2 \cos \theta / C \quad \text{kN-m (tf-m, Ltf-ft)}$$

where

- P = steering gear relief valve setting pressure, bar (kgf/cm², psi)
- N = number of active pistons or vanes
- A = area of piston or vane, mm² (cm², in²)
- L_2 = torque arm, equal the distance from the point of application of the force on the arm to the center of the rudder stock at zero (0) degrees of rudder angle, m (ft)
- C = factor, 10000 (1000, 2240)
- θ = maximum permissible rudder angle (normally 35 degrees)

5.13.2(b) *Maximum allowable torque for rudder stock.* The maximum allowable torque, T_{ar} , for the actual rudder stock diameter is to be determined in accordance with the following equation:

$$T_{ar} = 2.0(D_r/N_u)^3/K_s \quad \text{kN-m (tf-m, Ltf-ft)}$$

where

- K_s = material factor for rudder stock (see 3-2-14/1.3)
- D_r = actual rudder stock diameter at minimum point below the tiller or the rotor, mm (in.)
- N_u = factor, 42.0 (89.9, 2.39)

7 Mechanical Component Design

7.1 Mechanical Strength

All mechanical components which transmit force to or from the rudder are to have strength equivalent to that of the Rule required upper rudder stock (see 4-3-4/1.5.8).

7.3 Rudder Actuators

7.3.1 Design

Rudder actuators are to be designed in accordance with the requirements of pressure vessels in Section 4-4-1, except that the maximum allowable stress S is not to exceed the lower of the following:

$$\frac{U}{A} \text{ or } \frac{Y}{B}$$

where

- U = minimum specified tensile strength of material at room temperature
 Y = minimum specified yield point or yield strength

A and B are factors given below:

	<i>Rolled or forged steel</i>	<i>Cast steel</i>	<i>Nodular cast iron</i>
A	3.5	4	5
B	1.7	2	3

For requirements relative to vessels intended to carry oil, chemicals, or liquefied gases in bulk of 10,000 gross tonnage and over, but less than 100,000 tonnes deadweight, fitted with non-duplicated rudder actuators, see 4-3-4/25.5.

7.3.2 Oil Seals

Oil seals between non-moving parts forming part of the exterior pressure boundary are to be of the metal upon metal type or of an equivalent type. Oil seals between moving parts forming part of the external pressure boundary are to be fitted in duplicate so that the failure of one seal does not render the actuator inoperative. Alternative seal arrangements may be acceptable provided equivalent protection against leakage can be assured.

7.5 Tillers, Quadrants and Other Mechanical Parts

7.5.1 General

All steering gear parts, such as tillers, quadrants, rams, pins, tie rods and keys, which transmit force to or from the rudder, are to be proportioned so as to have strength equivalent to that of the Rule required upper rudder stock, taking into consideration the difference in materials between the rudder stock and the component.

7.5.2 Tillers and Quadrants

7.5.2(a) *Tiller or quadrant hub*. Dimensions of the hub are to be as follows (use consistent system of units):

- i) Depth of the hub is not to be less than S .
- ii) Mean thickness of the hub is not to be less than $S/3$.
- iii) Notwithstanding 4-3-4/7.5.2(a)ii) above, the polar section modulus of the hub is not to be less than that given below:

$$0.196S^3 \frac{K_h}{K_s}$$

where

- S = Rule-required upper rudder stock diameter
 K_s = material factor of rudder stock (see 3-2-14/1.3)
 K_h = material factor of hub (see 3-2-14/1.3)

7.5.2(b) *Tiller or quadrant arm*. The section modulus of the tiller or quadrant arm anywhere along its length is not to be less than that given below (use consistent system of units):

$$\frac{0.167S^3(L_2 - L_1)}{L_2} \cdot \frac{K_t}{K_s}$$

where

L_2 = distance from the point of application of the force on the arm to the center of the rudder stock

L_1 = distance between the section of the arm under consideration and the center of the rudder stock

K_t = material factor of tiller or quadrant arm (see 3-2-14/1.3)

Other symbols are as defined above.

7.5.2(c) *Bolted hub.* Split or semi-circular tiller or quadrant hubs assembled by bolting are to have bolts on any side having a total cross-sectional area not less than that given below (use a consistent system of units):

$$\frac{0.196S^3}{L_3} \cdot \frac{K_b}{K_s}$$

where

L_3 = distance between the center of the bolts and the center of the rudder stock

K_b = material factor of bolt (see 3-2-14/1.3)

Other symbols are as defined above.

The thickness of the bolting flange is not to be less than the minimum required diameter of the bolt.

7.5.2(d) *Tiller pin.* The total effective shear area of the tiller pin is not to be less than that given below. (Use consistent system of units):

$$\frac{0.196S^3}{L_2} \cdot \frac{K_p}{K_s}$$

where

K_p = material factor of the pin (see 3-2-14/1.3)

Other symbols are defined above.

7.5.3 Tie Rod

For multiple rudder installations or similar, where tie rod (or jockey bar) is fitted between tillers to synchronize them, the buckling strength of the tie rod is not to be less than that given below (use a consistent system of units):

$$\frac{0.113S^3 U_R}{L_2}$$

where

U_R = ultimate tensile strength of the rudder stock

Other symbols are defined above.

7.7 Rudder Stock to Tiller/Quadrant Connection

7.7.1 Key

The effective area of the key in shear is not to be less than that given below (use a consistent system of units):

$$\frac{0.196S^3}{r} \cdot \frac{K_k}{K_s}$$

where

- S = Rule-required upper rudder stock diameter
 r = actual rudder stock radius at mid length of key
 K_s = material factor of rudder stock (see 3-2-14/1.3)
 K_k = material factor of key (see 3-2-14/1.3)

Bearing stresses of the tiller and rudder stock keyways are not to be more than 90% of the applicable material yield stress.

7.7.2 Keyless Coupling

Hydraulic or shrink fitted keyless coupling is to be based on preload stress calculations and fitting procedures. The calculated torsional holding capacity is to be at least 2.0 times the transmitted torque based on the steering gear relief valve setting. The coefficient of friction for the oil injection method of fit is to be taken as no greater than 0.14 and that for dry method is to be taken as no greater than 0.17. Preload stress is not to exceed 90% of the minimum yield strength. Maximum equivalent Von-Mises Stress is not to exceed minimum yield strength considering all loads including preload stress and two times transmitted torque.

7.9 Welding

All welded joints within the pressure boundary of a rudder actuator or connecting parts transmitting mechanical loads are to be full penetration type or to be of other approved design.

9 Hydraulic System

9.1 System Design

9.1.1 General

The hydraulic system is to be fitted with two or more power units, see 4-3-4/5.1. It may be fitted with a single hydraulic rudder actuator unless required otherwise by 4-3-4/5.3.

9.1.2 Piping Arrangements

Piping is to be arranged such that:

- Single failure criteria in 4-3-4/5.5 are met.
- Transfer between power units can be readily effected.
- Air may be bled from the system.

9.1.3 Hydraulic Lock

Hydraulic lock may occur where a piping system is arranged such that malfunctions (for example, in directional valves or in the valve control) can cause power units to work in a closed circuit against each other rather than in parallel delivering fluid to the rudder actuator, thus resulting in loss of steering. Where a single failure can lead to hydraulic lock and loss of steering, an audible and visual hydraulic lock alarm, which identifies the failed system, is to be provided on the navigation bridge. See also Note 4 of 4-3-4/Table 1.

Alternatively, an independent steering failure alarm for follow-up control systems complying with the following requirements may be provided in lieu of a hydraulic lock alarm.

Where an independent steering failure alarm is installed for follow-up control systems, it is to comply with the following:

9.1.3(a) The steering failure alarm system is to actuate an audible and visible alarm in the wheelhouse when the actual position of the rudder differs by more than 5 degrees from the rudder position ordered by the follow-up control systems for more than:

- 30 seconds for ordered rudder position changes of 70 degrees;
- 6.5 seconds for ordered rudder position changes of 5 degrees; and

The time period calculated by the following formula for ordered rudder positions changes between 5 degrees and 70 degrees:

$$t = (R/2.76) + 4.64$$

where:

- t = maximum time delay in seconds
 R = ordered rudder change in degrees

9.1.3(b) The steering failure alarm system must be separate from, and independent of, each steering gear control system, except for input received from the steering wheel shaft.

9.1.3(c) Each steering failure alarm system is to be supplied by a circuit that:

- i) Is independent of other steering gear system and steering alarm circuits.
- ii) Is fed from the emergency power source through the emergency distribution panel in the wheelhouse, if installed; and
- iii) Has no overcurrent protection except short circuit protection

9.1.4 Isolation Valves

Isolating valves are to be fitted on the pipe connections to the rudder actuators. For vessels with non-duplicated rudder actuators, the isolating valves are to be directly mounted on the actuator.

9.1.5 Filtration

A means is to be provided to maintain the cleanliness of the hydraulic fluid.

9.1.6 System Overpressure Protection

Relief valves are to be provided for the protection of the hydraulic system at any part which can be isolated and in which pressure can be generated from the power source or from external forces. Each relief valve is to be capable of relieving not less than 110% of the full flow of the pump(s) which can discharge through it. With this flow condition, the maximum pressure rise is not to exceed 10% of the relief valve setting, taking into consideration increase in oil viscosity for extreme ambient conditions.

The relief valve setting is to be at least 1.25 times the maximum working pressure (see 4-3-4/1.5.5), but is not to exceed the maximum design pressure (see 4-3-4/9.5.1).

9.1.7 Fire Precautions

Where applicable, the provisions of 4-6-7/3.7.1 are to be met.

9.3 Hydraulic Oil Reservoir and Storage Tank

In addition to the power unit reservoir, a fixed hydraulic oil storage tank independent of the reservoir is to be provided for vessels of 500 gross tons and above. The storage tank is to have sufficient capacity to recharge at least one power actuating system, including the power unit reservoir. The tank is to be permanently connected by piping in such a manner that the system can be readily recharged from a position within the steering gear compartment. The storage tank is to be provided with an approved level indicating system.

See also 4-6-7/3.3 for arrangements of the power unit reservoir and the storage tank.

9.5 Piping Design

9.5.1 System Pressure

Hydraulic system piping is to be designed to at least 1.25 times the maximum working pressure (4-3-4/1.5.5), taking into account any pressure which may exist in the low-pressure side of the system.

9.5.2 Pipes and Pipe Fittings

Pipes and pipe branches are to meet the design requirements of 4-6-2/5.1 and 4-6-2/5.3. Pipe joints are to be in accordance with 4-6-2/5.5 in general, and 4-6-7/3.5.1 in particular. Particular attention is to be paid to footnotes 1 and 2 in 4-6-7/Table 1 where additional limitations on pipe joints are specified for steering gear hydraulic piping. See also 4-3-4/9.7.3.

9.7 Piping Components

9.7.1 Power Units

Power units are to be certified by ABS. See 4-3-4/5.1 and 4-3-4/19.5.

9.7.2 Rudder Actuators

Rudder actuators are to be design approved and are to be certified by ABS. See 4-3-4/5.3, 4-3-4/7.3 and 4-3-4/19.7.

9.7.3 Pipes and Pipe Fittings

For pipes and pipe fittings, refer to 4-3-4/9.5.2. Piping materials for hydraulic service are to be traceable to manufacturers' certificates, but need not be certified by ABS. See also 4-6-1/7 for certification of piping system components.

9.7.4 Other Piping Components

For valves, hoses and accumulators, refer to 4-6-7/3.5. For relief valve, see also 4-3-4/9.1.6.

9.7.5 Relief Valves

In addition to 4-3-4/9.7.4, discharge capacity test reports verifying the capacity required in 4-3-4/9.1.6 for all relief valves are to be submitted for review.

11 Electrical Systems

11.1 Power Supply Feeders

Each electric or electro-hydraulic steering gear is to be served by at least two exclusive circuits, fed directly from the main switchboard; however, one of the circuits may be supplied through the emergency switchboard. Each of duplicated power units required by 4-3-4/5.1 is to be served by one of these circuits. The circuits supplying an electric or electro-hydraulic steering gear are to have adequate rating for supplying all motors, control systems and instrumentation which are normally connected to them and operated simultaneously. The circuits are to be separated throughout their length as widely as is practicable. See also 4-8-2/7.11 for the steering gear power supply.

11.3 Electrical Protection

11.3.1 General

Each steering gear feeder is to be provided with short-circuit protection which is to be located at the main or the emergency switchboard, as applicable. Power unit motor overload protection is normally not to be provided, except as indicated in 4-3-4/11.3.3. Other means of protection, namely, motor overload alarm and motor phase failure alarm, as applicable, are to be provided as indicated in 4-3-4/Table 1 item d. See also 4-8-2/9.17.5 for protection of the steering gear feeder circuit.

11.3.2 Direct Current Motors

The feeder circuit breaker is to be set to trip instantaneously at not less than 300% and not more than 375% of the rated full-load current of the steering gear motor, except that the feeder circuit breaker on the emergency switchboard may be set to trip at not less than 200%.

11.3.3 Alternating Current Motors

In addition to short circuit protection, overload protection may be permitted if it is set at a value not less than 200% of the full load current of the motor (or of all the loads on the feeder), and is to be arranged to permit the passage of the starting current.

11.3.4 Fuses

The use of fuses instead of circuit breakers for steering gear motor feeder short circuit protection is not permitted.

11.5 Undervoltage Release

Power unit motor controllers and other automatic motor controllers are to be fitted with undervoltage release (capable of restarting automatically when power is restored after a power failure).

11.7 Motor Rating

11.7.1 Steering Gears with Intermittent Working Duty

Electric motors of and converters associated with electro-hydraulic steering gears with intermittent working duty are to be at least of 25% non-periodic duty rating (corresponding to S6 of IEC Publication 60034-1), as per 4-8-3/3.3.3 and 4-8-3/Table 4. Electric motors of electro-mechanical steering gears are, however, to be at least of 40% non-periodic duty rating (corresponding to S3 of IEC Publication 60034-1).

11.7.2 Steering Gears with Continuous Working Duty

Electric motors of and converters associated with steering gears with continuous working duty are to be of continuous rating (corresponding to S1 of IEC Publication 60034-1), as per 4-8-3/3.3.4 and 4-8-3/Table 4.

11.9 Emergency Power Supply

Where the required rudder stock diameter (see 4-3-4/1.5.8) is over 230 mm (9 inches), an alternative power supply, sufficient at least to supply one steering gear power unit and its associated control system and the rudder angle indicator, is to be provided automatically within 45 seconds either from the emergency source of electrical power or from an independent source of power located in the steering gear compartment. This independent source of power is to be used only for this purpose.

The steering gear power unit under alternative power supply is to be capable of moving the rudder from 15° on one side to 15° on the other side in not more than 60 seconds with the vessel at the summer draft while running at one half the maximum ahead service speed or 7 knots, whichever is the greater [see 4-3-4/1.9ii)].

In every vessel of 10,000 gross tonnage and upwards, the alternative power supply is to have a capacity for at least 30 minutes of continuous operation and in any other vessel for at least 10 minutes.

13 Control Systems

13.1 General

13.1.1 Redundancy

There are to be two independent control systems (see definition in 4-3-4/1.5.6) provided, each of which can be operated from the navigation bridge. These control systems are to be independent in all respects and are to provide on the navigation bridge all necessary apparatus and arrangements for the starting and stopping of steering gear motors and the rapid transfer of steering power and control between units.

Control cables and piping for the independent control systems are to be separated throughout their length, as widely as is practicable.

Wires, terminals and the components for duplicated steering gear control systems installed in units, control boxes, switchboards or bridge consoles are to be separated throughout their length as widely as is practicable. Where physical separation is not practicable, separation may be achieved by means of a fire retardant plate.

13.1.2 Local Steering Gear Control

Local steering gear control is to be provided in the steering gear compartment. However, if the power unit is located in a space other than the steering compartment, the local control is to be provided in that space instead of the steering compartment. For the purpose of local control from the steering gear compartment (or the space containing the power unit), a means is to be provided in the steering compartment (or the space containing the power unit) to disconnect any control system from the navigation bridge. Such means for disconnecting are to be operable by a single person without the need for tools. See 4-3-4/13.5.1.

13.1.3 Duplication

All electric components of the steering gear control system are to be duplicated. This does not require duplication of a steering wheel or steering lever.

13.1.4 Steering Mode Selector Switch

If a joint steering mode selector switch (uniaxial switch) is employed for both steering gear control systems, the connections for the circuits of the control systems are to be divided accordingly and separated from each other by an isolating plate or by air gap.

13.1.5 Follow-up Amplifier

In the case of double follow-up control, the amplifiers are to be designed and fed so as to be electrically and mechanically separated. In the case of non-follow-up control and follow-up control, the follow-up amplifiers are to be protected selectively.

13.1.6 Additional Control Systems

Control circuits for additional control systems (e.g., steering lever or autopilot) are to be designed for all-pole disconnection.

13.1.7 Feed-back Units and Limit Switches

The feed-back units and limit switches, if any, for the steering gear control systems are to be separated electrically and mechanically connected to the rudder stock or actuator separately.

13.1.8 Hydraulic Control Components

Hydraulic system components in the power actuating or hydraulic servo systems controlling the power systems of the steering gear (e.g., solenoid valves, magnetic valves) are to be considered as part of the steering gear control system and shall be duplicated and separated.

Hydraulic system components in the steering gear control system that are part of a power unit may be regarded as being duplicated and separated when there are two or more separate power units provided and the piping to each power unit can be isolated.

13.1.9 System Response Under Failure

The failures (as listed, but not limited to those items in 4-3-4/Table 1) likely to cause uncontrolled movements of rudder are to be clearly identified. In the event of detection of such failure, the rudder should stop in the current position. Alternatively, the rudder may be set to return to the midship/neutral position. Failure Mode and Effect Analysis methodology may be used to identify the failures.

13.3 Power Supply

If the control systems operable from the navigation bridge are electric, then each system is to be served by its own separate circuits supplied from a steering gear power circuit in the steering gear compartment, or directly from the switchboard bus bars supplying that steering gear power circuit at a point on the switchboard adjacent to the supply to the steering gear power circuit.

Circuits supplying power to steering gear controls are to be provided with short-circuit protection only.

13.5 Control System Override

13.5.1 Steering Gear Compartment

Means are to be provided in the steering gear compartment to disconnect the steering gear control system from the power circuit when local control is to be used. Additionally, if more than one steering station is provided, a selector switch is to disconnect completely all stations, except the one in use.

13.5.2 Autopilot

13.5.2(a) Steering gear systems provided with an autopilot system are to have a device at the primary steering station to completely disconnect the autopilot control to permit change over to manual operation of the steering gear control system. A display is to be provided at the steering station to ensure that the helmsman can readily and clearly recognize which mode of steering control (autopilot or manual) is in operation.

13.5.2(b) In addition to the changeover device as in 4-3-4/13.5.2(a), for primary steering stations, where fitted with an automatic autopilot override to change over from autopilot control to manual operation, the following are to be provided.

- i)* The automatic override of the autopilot is to occur when the manual helm order is 5 degrees of rudder angle or greater.
- ii)* An audible and visual alarm is to be provided at the primary steering station in the event that the automatic autopilot override fails to respond when the manual helm order is 5 degrees of rudder angle or greater. The alarm is to be separate and distinct from other bridge alarms, and is to continue to sound until it is acknowledged.
- iii)* An audible and visual alarm that is immediately activated upon automatic autopilot override actuation is to be provided at the primary steering station. The alarm is to be distinct from other bridge alarms, and is to continue to sound until it is acknowledged.

13.7 Hydraulic Telemotor

Where the control system consists of a hydraulic telemotor, a second independent system need not be fitted, except in oil or fuel oil carriers, chemical carriers, or gas carriers of 10,000 gross tonnage and above (see also 4-3-4/25).

13.9 Computer-based Systems

Steering control systems that are computer-based systems are to comply with Section 4-9-3 and are to be considered system category III.

15 Instrumentation

Instruments for monitoring the steering gear system are to be provided, as indicated in 4-3-4/Table 1. All alarms are to be audible and visual and are to be of the self-monitoring type so that a circuit failure will cause an alarm condition. There are to be provisions for testing alarms.

TABLE 1
Steering Gear Instrumentation

<i>Monitored Parameters</i>	<i>Display/Alarm</i>	<i>Location</i>
a) Rudder angle indicator ⁽¹⁾	Display	<ul style="list-style-type: none"> • Navigation bridge • Steering gear compartment
b) Power unit motor running	Display	<ul style="list-style-type: none"> • Navigation bridge • Engine room control station
c) Power unit power supply failure	Alarm	<ul style="list-style-type: none"> • Navigation bridge • Engine room control station
d) Power unit motor overload ⁽²⁾	Alarm	<ul style="list-style-type: none"> • Navigation bridge • Engine room control station
e) Power unit motor phase failure ^{(2), (3)}	Alarm	<ul style="list-style-type: none"> • Navigation bridge • Engine room control station
f) Control power failure	Alarm	<ul style="list-style-type: none"> • Navigation bridge • Engine room control station
g) Hydraulic oil reservoir low level ⁽²⁾	Alarm	<ul style="list-style-type: none"> • Navigation bridge • Engine room control station
h) Hydraulic lock ⁽⁴⁾	Alarm	<ul style="list-style-type: none"> • Navigation bridge
i) Auto-pilot running ⁽⁵⁾	Display	<ul style="list-style-type: none"> • Navigation bridge
j) Auto-pilot failure ⁽⁵⁾	Alarm	<ul style="list-style-type: none"> • Navigation bridge
k) Steering mode (autopilot/manual) indication	Display	<ul style="list-style-type: none"> • Navigation bridge
l) Automatic autopilot ⁽⁵⁾ override failure	Alarm	<ul style="list-style-type: none"> • Navigation bridge
m) Automatic autopilot ⁽⁵⁾ override activated	Alarm	<ul style="list-style-type: none"> • Navigation bridge
n) Loop failures ⁽⁶⁾	Alarm	<ul style="list-style-type: none"> • Navigation bridge
o) Computer-based system failures ⁽⁷⁾	Alarm	<ul style="list-style-type: none"> • Navigation bridge
p) Earth fault on AC and DC circuits	Alarm	<ul style="list-style-type: none"> • Navigation bridge
q) Deviation between rudder order and feedback	Alarm	<ul style="list-style-type: none"> • Navigation bridge

Notes

- 1 The rudder angle indication is to be independent of the steering gear control system, and readily visible from the control position.
- 2 The operation of this alarm is not to interrupt the circuit.
- 3 For three phase AC supply only.
- 4 The alarm is to be activated when the position of the variable displacement pump control system does not correspond to the given order; or when the incorrect position of the 3-way full flow valve or similar in the constant delivery pump system is detected. Monitoring for hydraulic lock is not required, when a steering failure alarm system is provided. See 4-3-4/9.1.3(a), (b) and (c).
- 5 If provided.
- 6 Monitoring is to be provided for short circuit, broken connections and earth faults for command and feedback loops. Monitoring for loop failures is not required, when a steering failure alarm system is provided. See 4-3-4/9.1.3(a), (b) and (c).
- 7 For steering control systems that are computer-based systems, monitoring is to be provided for data communication errors, computer hardware failures and software failure. See also Section 4-9-3. Monitoring for computer-based system failures is not required, when a steering failure alarm system is provided. See 4-3-4/9.1.3(a), (b) and (c).

17 Communications

A means of communication is to be provided between the navigation bridge and the steering gear compartment including all other locations where steering can be effected. Additionally, communication is to be provided between these spaces and the main propulsion control station, in accordance with 4-8-2/11.5.

19 Certification

19.1 General

Steering gear components are to be inspected, tested and certified by a Surveyor at the plant of manufacture in accordance with the following requirements. Hydraulic oil pumps are to be certified, see 4-6-1/7.3.1i).

19.3 Material Testing

For testing of steering gear component materials, see 4-3-4/3.3.

19.5 Prototype Tests of Power Units

Where the Rules required upper rudder stock diameter is 120 mm (4.7 in.) or greater, power units are to be tested and certified in accordance with the following requirements. For required upper rudder stock diameter less than 120 mm (4.7 in.), and where the vessel is 500 gross tons or greater, power units are to be tested and certified in accordance with 4-6-1/7.3 only. For vessels less than 500 gross tons, power units may be accepted based on manufacturer's guarantee for suitability for the intended purpose and subject to satisfactory functional tests after installation.

A prototype of each new design power unit pump is to be shop tested for a duration of not less than 100 hours. The testing is to be carried out in accordance with an approved program and is to include the following as a minimum:

- i) The pump and stroke control (or directional control valve) is to be operated continuously from full flow and relief valve pressure in one direction through idle to full flow and relief valve pressure in the opposite direction.
- ii) Pump suction conditions are to simulate lowest anticipated suction head. The power unit is to be checked for abnormal heating, excessive vibration or other irregularities. Following the test, the power unit pump is to be disassembled and inspected in the presence of a Surveyor.

19.7 Components Shop Tests

Each component of the steering gear piping system, including the power units, rudder actuators and piping, is to be inspected by a Surveyor during fabrication, and hydrostatically tested to 1.5 times the relief valve setting (or system design pressure) in the presence of a Surveyor.

21 Installation, Tests and Trials

21.1 Steering Gear Seating

Steering gears are to be bolted to a substantial foundation effectively attached to the hull structure. Suitable chocking arrangements are to be provided to the satisfaction of the Surveyor.

21.3 Operating Instructions

Appropriate operating instructions with a block diagram showing changeover procedures for steering gear control systems and steering gear power units are to be permanently displayed on the navigation bridge and in the steering gear compartment. Where failure alarms are provided to indicate hydraulic locking, instructions are to be permanently posted on the navigation bridge and in the steering gear compartment for the operator to shut down the failed system.

21.5 Installation Tests

After installation on board the vessel, the complete piping system, including power units, rudder actuators and piping, is to be subjected to a hydrostatic test equal to 110% of the relief valve setting, including a check of the relief valve operation in the presence of the Surveyor.

21.7 Sea Trials

The steering gear is to be tried out on the trial trip in order to demonstrate to the Surveyor's satisfaction that the requirements of this section have been met. The trials are to be performed with the rudder fully submerged. Where full rudder submergence cannot be obtained in ballast conditions, steering gear trials are to be conducted at a displacement as close as reasonably possible to full-load displacement as required by Section 6.1.2 of ISO 19019:2005 on the conditions that either:

- i) The rudder is fully submerged (zero speed waterline) and the vessel is in an acceptable trim condition.
- ii) The rudder load and torque at the specified trial loading condition have been predicted (based on the system pressure measurement) and extrapolated to the full load condition using the following method to predict the equivalent torque and actuator pressure at the deepest seagoing draft:

$$Q_F = Q_T \alpha$$

$$\alpha = 1.25 \left(\frac{A_F}{A_T} \right) \left(\frac{V_F}{V_T} \right)^2$$

where

- α = extrapolation factor
- Q_F = rudder stock moment for the deepest service draught and maximum service speed condition
- Q_T = rudder stock moment for the trial condition
- A_F = total immersed projected area of the movable part of the rudder in the deepest seagoing condition
- A_T = total immersed projected area of the movable part of the rudder in the trial condition
- V_F = contractual design speed of the vessel corresponding to the maximum continuous revolutions of the main engine at the deepest seagoing draft
- V_T = measured speed of the vessel (considering current) in the trial condition

Where the rudder actuator system pressure is shown to have a linear relationship to the rudder stock torque the above equation can be taken as:

$$P_F = P_T \alpha$$

where

- P_F = estimated steering actuator hydraulic pressure in the deepest seagoing draft condition
- P_T = maximum measured actuator hydraulic pressure in the trial condition

Where constant volume fixed displacement pumps are utilized, the requirements can be deemed satisfied if the estimated steering actuator hydraulic pressure at the deepest draft is less than the specified maximum working pressure of the rudder actuator. Where a variable delivery pump is utilized, pump data should be supplied and interpreted to estimate the delivered flow rate that corresponds to the deepest seagoing draft in order to calculate the steering time and allow it to be compared to the required time.

Where A_T is greater than $0.95A_F$, there is no need for extrapolation methods to be applied.

- iii) Alternatively the designer or builder may use computational fluid dynamic (CFD) studies or experimental investigations to predict the rudder stock moment at the full sea going draft condition and service speed. These calculations or experimental investigations are to be to the satisfaction of ABS.

In any case for the main steering gear trial, the speed of ship corresponding to the number of maximum continuous revolution of main engine and maximum design pitch applies.

21.7.1 Full Speed Trial

Satisfactory performance is to be demonstrated under the following conditions:

- i) Changing the rudder position from 35° on either side to 30° on the other side in not more than 28 seconds with the vessel running ahead at the maximum continuous rated shaft rpm. For controllable pitch propellers, the propeller pitch is to be at the maximum design pitch approved for the above maximum continuous ahead rated rpm.
- ii) Unless 4-3-4/21.7.2iii), 4-3-4/23.3 or 4-3-4/25.7 is applicable, this test is to be carried out with all power units intended for simultaneous operation for this condition under actual operating conditions.

21.7.2 Half Speed Trial

Satisfactory performance is to be demonstrated under the following conditions.

- i) Changing the rudder position from 15° on either side to 15° on the other side in not more than 60 seconds while running at one-half of the maximum ahead speed or 7 knots whichever is the greater.
- ii) This test is to be conducted with either one of the power units used in 4-3-4/21.7.1ii) in reserve.
- iii) This test may be waived where the steering gear consists of two identical power units with each capable of meeting the requirements in 4-3-4/21.7.1i).

21.7.3 Steering Gears with More than Two Power Units

Where three or more power units are provided, the test procedures are to be specially considered on the basis of the specifically approved operating arrangements of the steering gear system.

21.7.4 Additional Items

The trial is also to include the operation and verification of the following:

- i) The power units, including transfer between power units.
- ii) The emergency power supply, if applicable.
- iii) The steering gear controls, including transfer of control and local control.
- iv) The means of communication between the navigation bridge, engine room and the steering gear compartment.
- v) The alarms and indicators required by 4-3-4/15 above (test may be done at dockside).
- vi) The storage and recharging system in 4-3-4/9.3 above (test may be done at dockside).
- vii) The isolation of one power actuating system and time for regaining steering capability (test may be done at dockside).
- viii) Where the steering gear is designed to avoid hydraulic locking (4-3-4/9.1.3 above), this feature is to be demonstrated.
- ix) Where practicable, simulation of a single failure in the hydraulic system, and demonstration of the means provided to isolate it and the regaining of steering capability, as in 4-3-4/5.5 and 4-3-4/9.1.3 above.
- x) The stopping of the steering gear before the rudder stop is reached, as in 4-3-4/5.11 above.

23 Additional Requirements for Passenger Vessels

23.1 Performance

The steering gear is to be designed to be capable of operating the rudder, as required by 4-3-4/1.9i), with any one of the power units inoperative.

23.3 Sea Trials

The performance test criteria in 4-3-4/21.7.1i) is to be demonstrated during sea trial with any one of the power units in reserve.

25 Additional Requirements for Oil or Fuel Oil Carriers, Chemical Carriers and Gas Carriers

25.1 Vessels of 10,000 Gross Tonnage and Upwards

25.1.1 Single Failure Criterion

The steering gear is to be so arranged that in the event of the loss of steering capability due to a single failure in any part of one of the power actuating systems (see 4-3-4/1.5.3), excluding the tiller, quadrant or components serving the same purpose, or seizure of the rudder actuators, steering capability is to be regained in not more than 45 seconds.

25.1.2 Power Actuating System

The steering gear is to comprise either:

- i) Two independent and separate power actuating systems, each capable of meeting the requirements of 4-3-4/1.9i); or
- ii) At least two identical power actuating systems which, acting simultaneously in normal operation, is to be capable of meeting the requirements of 4-3-4/1.9i). Where necessary to comply with this requirement, interconnection of hydraulic power actuating systems may be provided. Loss of hydraulic fluid from one system is to be capable of being detected and the defective system automatically isolated so that the other actuating system or systems is to remain fully operational.

The electric power and control system for the above automatic isolating system is to be of fail-safe design, see 4-9-3/5.1.8 and is to have a self-monitoring feature, see 4-9-2/7.13. Where the automatic isolating system is a computer-based system, the system is to be of Category III in accordance with 4-3-4/13.9.

25.1.3 Non-hydraulic Steering Gears

Steering gears other than of the hydraulic type is to achieve equivalent standards.

25.3 Alternative for Vessels 10,000 Gross Tonnage and Upwards but Less than 100,000 Tonnes Deadweight

Vessels within this size range, in lieu of completely meeting the requirements in 4-3-4/25.1, may, as an alternative, exclude the application of single failure criterion to rudder actuator, provided that an equivalent safety standard is achieved and that:

- i) Following the loss of steering capability due to a single failure of any part of the piping system or in any one of the power units, steering capability is to be regained within 45 seconds; and
- ii) The single rudder actuator meets the requirements of 4-3-4/25.5.

25.5 Non-duplicated Rudder Actuators for Vessels of 10,000 Gross Tonnage and Upwards but Less than 100,000 Tonnes Deadweight

For oil or fuel oil carriers, chemical carriers or gas carriers of 10,000 gross tonnage and upwards but of less than 100,000 tonnes deadweight, a single rudder actuator may be accepted, provided the following additional requirements are complied with.

25.5.1 Analysis

Detailed calculations are to be submitted for the rudder actuator to show the suitability of the design for the intended service. This is to include a stress analysis of the pressure retaining parts of the actuator to determine the stresses at the design pressure.

Where considered necessary due to the design complexity or manufacturing procedures, a fatigue analysis and fracture mechanic analysis may be required. In connection with these analyses, all foreseen dynamic loads are to be taken into account. Experimental stress analysis may be required in addition to, or in lieu of, theoretical calculations depending on the complexity of the design.

25.5.2 Allowable Stresses

For the purpose of determining the general scantlings of parts of rudder actuators subject to internal hydraulic pressure, the allowable stresses are not to exceed:

$$\sigma_m \leq f$$

$$\sigma_\ell \leq 1.5f$$

$$\sigma_b \leq 1.5f$$

$$\sigma_\ell + \sigma_b \leq 1.5f$$

$$\sigma_m + \sigma_b \leq 1.5f$$

where

σ_m = equivalent primary general membrane stress

σ_ℓ = equivalent primary local membrane stress

σ_b = equivalent primary bending stress

σ_B = specified minimum tensile strength of material at ambient temperature

σ_Y = specified minimum yield stress or 0.2 percent proof stress of material at ambient temperature

f = the lesser of σ_B/A or σ_Y/B , where A and B are as follows:

	<i>Steel</i>	<i>Cast steel</i>	<i>Nodular cast iron</i>
<i>A</i>	4	4.6	5.8
<i>B</i>	2	2.3	3.5

25.5.3 Burst Test

Pressure retaining parts not requiring fatigue analysis and fracture mechanic analysis may be accepted on the basis of a certified burst test and the detailed stress analysis required by 4-3-4/25.5.1 need not be submitted.

The minimum bursting pressure is to be calculated as follows:

$$P_b = PA \frac{\sigma_{Ba}}{\sigma_B}$$

where

P_b = minimum bursting pressure

P = design pressure as defined in 4-3-4/9.5.1

A = from table in 4-3-4/25.5.2

σ_{Ba} = actual tensile strength

σ_B = tensile strength as defined in 4-3-4/25.5.2

25.5.4 Nondestructive Testing

The rudder actuator is to be subjected to complete nondestructive testing to detect both surface flaws and volumetric flaws. The procedure and acceptance criteria are to be in accordance with the requirements of recognized standards or as may be determined by approved fracture mechanic analysis.

25.7 Sea Trials

For vessels having two independent and separate power actuating systems as per 4-3-4/25.1.2i), the performance test criteria in 4-3-4/21.7.1i) are to be demonstrated during sea trial with any one of the power units in reserve. The capabilities of the steering gear to function as required in 4-3-4/25.1.1 and 4-3-4/25.3, as applicable, are also to be demonstrated.

PART

4

CHAPTER 3 Propulsion and Maneuvering Machinery

SECTION 5 Thrusters

1 General

1.1 Application

The provisions of this section apply to maneuvering thrusters not intended to assist in propulsion, and to azimuthal and non-azimuthal thrusters (and to alternative propulsion and steering systems without a rudder, as applicable) intended for propulsion, maneuvering or dynamic positioning, or a combination of these duties.

Maneuvering thrusters intended to assist maneuvering and dynamic positioning thrusters, where fitted, may, at the request of the owners, be certified in accordance with the provisions of this section. In such cases, appropriate class notations, as indicated in 4-3-5/1.3, will be assigned upon verification of compliance with corresponding provisions of this section.

Thrusters intended for propulsion with or without combined duties for assisting in maneuvering or dynamic positioning are to comply with appropriate provisions of this section in association with other relevant provisions of Part 4, Chapter 3.

Thruster types not provided for in this section, such as cycloidal propellers, pump or water-jet type thrusters, will be considered, based on the manufacturer's submittal on design and engineering analyses.

Thrusters are to be constructed with sufficient strength, capacity and the necessary supporting systems to provide reliable propulsion and steering to the vessel in all operating conditions. Special consideration will be given to the suitability of any essential component which is not duplicated.

For a vessel fitted with multiple steering systems, each steering system is to be so arranged that the failure of one of them will not render the other one inoperative. Each of the steering systems is equipped with its own dedicated steering gear, provided that each of the steering systems is fulfilling the requirements for main steering gear (as given in 4-3-5/5.12.1) and each of the steering systems is provided with an additional function for positioning and locking the failed steering system in a neutral position after a failure of its own power unit(s) and actuator(s).

1.3 Class Notations

1.3.1 APS Notation

Self-propelled vessels, where fitted with thrusters capable of producing thrusts primarily in the athwartship direction and intended to assist in maneuvering the vessel, at the discretion of the owners, may comply with the provisions of 4-3-5/1 through 4-3-5/13 of this section. And upon verification of compliance, the class notation **APS** (athwartship thruster) may be assigned.

1.3.2 PAS Notation

Non-self-propelled vessels, where fitted with thrusters to assist in the maneuvering or propelling while under tow, at the discretion of the owners, may comply with the provisions of 4-3-5/1 through 4-3-5/13 of this section; and upon verification of compliance, the class notation **PAS** (propulsion assist) may be assigned.

1.3.3 Dynamic Positioning Systems Notations

For dynamic positioning systems and associated notations, see the *ABS Guide for Dynamic Positioning Systems*.

1.5 Definitions

For the purpose of this section, the following definitions apply:

1.5.1 Thruster

1.5.1(a) General. Thrusters are devices capable of delivering side thrust or thrusts through 360° to improve the vessel's maneuverability, particularly in confined waters. There are three generic types of thrust-producing devices: the lateral or tunnel thruster, commonly known as 'bow-thruster', which consists of a propeller installed in a athwartship tunnel; jet type thruster, which consists of a pump taking suction from the keel and discharge to either side; and azimuthal thruster, which can be rotated through 360° so that thrust can be developed in any direction. Cycloidal propellers can be considered a type of azimuthal thruster.

1.5.1(b) Propeller-type thruster. Regardless of whether they are normally used for propulsion, propellers intended to be operated for an extended period of time during service in a condition where the vessel is not free running approximately along the direction of the thrust are to be considered thrusters for the purposes of this section.

1.5.2 Continuous Duty Thruster

A continuous duty thruster is a thruster designed for continuous operation, such as dynamic positioning thrusters, propulsion assist, or main propulsion units.

1.5.3 Intermittent Duty Thruster

An intermittent duty thruster is a thruster which is designed for operation at peak power or rpm levels, or both, for periods not exceeding one (1) hour followed by periods at the continuous rating or less, with total running time not exceeding eight (8) hours in twenty (20) hours. Generally, such thrusters are not meant to operate more than 1000 hours per year.

1.5.4 Declared Operational Limits

Declared steering angle limits and maximum rotational speed are operational limits in terms of maximum steering angle, and rotational speed, or equivalent, according declared guidelines for safe operation, also taking into account the vessel's speed or propeller torque/speed or other limitation. The "declared steering angle limits" and "maximum rotational speed" are to be established by the vessel's designer and shipbuilder based on the vessel specific non-traditional steering means. Vessels' maneuverability tests, such as IMO Standards for Ship Maneuverability, Resolution MSC.137(76) are to be carried out not exceeding the declared operational limits.

1.5.5 Steering Gear Power Unit

For purposes of alternative propulsion and steering arrangements, the steering gear power units are to be considered as defined in 4-3-4/1.5.2. For electric steering gears, the electric steering motor is to be considered as part of power unit and actuator.

1.5.6 Steering System

"Steering system" is a vessel's directional control system, including main steering gear, auxiliary steering gear, steering gear control system and rudder, if any.

1.7 Plans and Particulars to be Submitted

The general arrangements of the thruster installation, its location of installation, along with its supporting auxiliary machinery and systems, fuel oil tanks, foundations, watertight boundary fittings, etc., are to be submitted. The rated power/rpm and the rated thrust are to be indicated. For azimuthal thrusters, the mechanical and control systems for rotating the thruster assembly or for positioning the direction of thrust are to be submitted. In addition, plans of each component and of the systems associated with the thruster are to be submitted as detailed in the applicable sections of these Rules. Typically, the following are applicable:

Supporting structures:	Section 3-1-2 and 3-2-2/5.11
Diesel engine prime mover:	4-2-1/1.9
Electric motor and controller:	4-8-1/5.5.1 and 4-8-1/5.5.4

Gearing:	4-3-1/1.5
Shafting:	4-3-2/1.5
Propellers:	4-3-3/1.5
Piping system:	4-6-1/9
Control and instrumentation:	4-9-1/7

3 Materials

3.1 General

Materials entered into the construction of the torque-transmitting components of the thruster are to be in accordance with the applicable requirements of Part 4 of the Rules. For instance, material requirements for propellers are to be in accordance with 4-3-3/3; materials for gears, 4-3-1/3; materials for shafting, 4-3-2/3; materials for steering systems, 4-3-4/3.1, etc. All material specifications are contained in Part 2, Chapter 3.

Where alternative material specifications are proposed, complete chemical composition and mechanical properties similar to the material required by these Rules are to be submitted for approval.

3.3 Material Testing

3.3.1 Testing by a Surveyor

The materials of the following components are to be tested in the presence of a Surveyor for verification of their compliance with the applicable requirements of Part 2, Chapter 3, or such other appropriate material specifications as may be approved in connection with a particular design.

- Shafts, shaft flanges, keys
- Gears (propulsion and steering)
- Propellers
- Impellers
- Couplings
- Coupling bolts

Bolts manufactured to a recognized standard and used as coupling bolts need not to be tested in the presence of a Surveyor.

3.3.2 Thruster Rated 375 kW (500 hp) or Less

Materials for thrusters of 375 kW (500 hp) or less, including shafting, gears, pinions, couplings and coupling bolts may be accepted on the basis of the manufacturer's certified mill test reports and a satisfactory surface inspection and hardness check witnessed by a Surveyor.

5 Design

5.1 Prime Movers

5.1.1 Internal Combustion Engines

Internal combustion engines used for driving thrusters are to comply with the design, construction, testing and certification requirements of Part 4, Chapter 2. Engine support systems are to be in accordance with Section 4-6-5; except that standby pumps and similar redundancy specified for propulsion engines are not required for thruster engines.

5.1.2 Electric Motors

Electric motors driving thrusters are to comply with the design, construction, testing and certification requirements of Section 4-8-3. Power for thruster motors may be derived from ship service generators; except that precautions, such as interlock arrangements, are to be fitted to prevent starting except when there are enough generators on-line to support the starting and running of the thruster motor. All ship service generators may be put on line for this purpose, see 4-8-2/3.1.2.

5.1.3 Hydraulic Motors

Hydraulic motors delivering propulsion torque to thrusters are to be certified by the Surveyor at manufacturers' plants in accordance with 4-6-1/7.3. When applicable to notations **APS**, **PAS** and **DPS**, in addition to the required test, hydraulic motors are to be designed based on applicable pressure vessel and piping standards for pressure retaining components, allowable stress for torque components, and recognized standard for seals. As an alternative to design review, mass produced motors may be accepted on the basis of specification review and a prototype test to 150% of the rated load, subject to agreement on design standards and manufacturing process.

5.3 Propellers

5.3.1 General

In general, the thruster propellers are to comply with the requirements of Section 4-3-3, except as modified below.

5.3.2 Propeller Blades of Conventional Design

Where the propeller blades are of conventional design with skew angle not exceeding 25°, the thickness of the propeller blade is not to be less than determined by the following equations. Fillets at the root of the blades are not to be considered in the determination of the blade thickness.

5.3.2(a) *Fixed pitch propellers.* The minimum required blade thickness at 0.25 radius, $t_{0.25}$, is to be determined by the following equations:

$$t_{0.25} = K_1 \sqrt{\frac{AH}{C_n CRN}} \pm \left(\frac{C_s}{C_n} \right) \left(\frac{BK}{4C} \right) \quad \text{mm (in.)}$$

$$A = 1.0 + \frac{6.0}{P_{0.70}} + 4.3P_{0.25} \quad \text{for free running propellers}$$

$$A = 7.2 + \frac{2.0}{P_{0.70}} + 4.3P_{0.25} \quad \text{For propellers performing bollard pull, athwartship thrusting, dynamic positioning and similar duties;}$$

$$B = \frac{4300wa}{N} \left(\frac{R}{100} \right)^2 \left(\frac{D}{20} \right)^3$$

$$C = (1.0 + 1.5P_{0.25})(Wf - B)$$

Other symbols are defined in 4-3-5/5.3.2(d).

5.3.2(b) *Controllable pitch propellers.* The minimum required blade thickness at 0.35 radius, $t_{0.35}$, is to be determined by the following equations:

$$t_{0.35} = K_2 \sqrt{\frac{AH}{C_n CRN}} \pm \left(\frac{C_s}{C_n} \right) \left(\frac{BK}{6.3C} \right) \quad \text{mm (in.)}$$

$$A = 1.0 + \frac{6.0}{P_{0.70}} + 3P_{0.35} \quad \text{for free running propellers}$$

$$A = 7.2 + \frac{2.0}{P_{0.70}} + 3P_{0.35} \quad \text{for non-free running propellers [see 4-3-5/5.3.2(a)]}$$

$$B = \frac{4900wa}{N} \left(\frac{R}{100} \right)^2 \left(\frac{D}{20} \right)^3$$

$$C = (1.0 + 0.6P_{0.35})(Wf - B)$$

Other symbols are defined in 4-3-5/5.3.2(d).

5.3.2(c) *Nozzle propellers (wide-tip blades)*. The minimum required blade thickness at 0.35 radius, $t_{0.35}$, is to be determined by the following equations:

$$t_{0.35} = K_3 \sqrt{\frac{AH}{C_n CRN}} \pm \left(\frac{C_s}{C_n} \right) \left(\frac{BK}{5.6C} \right) \text{ mm (in.)}$$

$$A = 1.0 + \frac{6.0}{P_{0.70}} + 2.8P_{0.35} \quad \text{for free running propellers}$$

$$A = 7.2 + \frac{2.0}{P_{0.70}} + 2.8P_{0.35} \quad \text{for non-free running propellers [see 4-3-5/5.3.2(a)]}$$

$$B = \frac{4625wa}{N} \left(\frac{R}{100} \right)^2 \left(\frac{D}{20} \right)^3$$

$$C = (1.0 + 0.6P_{0.35}) (Wf - B)$$

Other symbols are defined in 4-3-5/5.3.2(d).

5.3.2(d) *Symbols*. The symbols used in the above formulas are defined, in alphabetical order, as follows (the units of measure are in SI (MKS and US) systems, respectively):

- a = expanded blade area divided by the disc area
- a_s = area of expanded cylindrical section at 0.25 or 0.35 radius, as applicable; mm² (in²)
- C_n = section modulus coefficient at 0.25 or 0.35 radius, as applicable; to be determined by the following equation:

$$C_n = \frac{I_0}{U_f WT^2}$$

If the value of C_n exceeds 0.1, the required thickness is to be computed with $C_n = 0.1$.

- C_s = section area coefficient at 0.25 or 0.35 radius, as applicable, to be determined by the following equation:

$$C_s = \frac{a_s}{WT}$$

The values of C_s and C_n computed as stipulated above are to be indicated on the propeller drawing. For vessels below 61 m (200 ft) in length, the required thickness may be computed with the assumed values of $C_n = 0.10$ and $C_s = 0.69$.

- D = propeller diameter; m (ft)
- f, w = material constants, see table below:

Material type	SI & MKS units		US units	
	f	w	f	w
2	2.10	8.3	68	0.30
3	2.13	8.0	69	0.29
4	2.62	7.5	85	0.27
5	2.37	7.5	77	0.27
CF-3	2.10	7.75	68	0.28

- H = power at rated speed; kW (PS, hp)
 I_0 = moment of inertia of the expanded cylindrical section at 0.25 or 0.35 radius about a straight line through the center of gravity parallel to the pitch line or to the nose-tail line; mm⁴ (in⁴)
 K = rake of propeller blade, in mm (in.) (positive for aft rake and negative for forward rake)

K_1 , K_2 , and K_3 are constants and are to be of values as specified below:

	<i>SI unit</i>	<i>MKS unit</i>	<i>US unit</i>
K_1	337	289	13
K_2	271	232	10.4
K_3	288	247	11.1

- N = number of blades
 $P_{0.25}$ = pitch at 0.25 radius divided by propeller diameter
 $P_{0.35}$ = pitch at 0.35 radius divided by propeller diameter, corresponding to the design ahead condition
 $P_{0.7}$ = pitch at 0.7 radius divided by propeller diameter, corresponding to the design ahead condition
 R = rpm at rated speed
 T = maximum design thickness at 0.25 or 0.35 radius from propeller drawing mm (in.)
 $t_{0.25}$ = required thickness of blade section at 0.25 of propeller radius; mm (in.)
 $t_{0.35}$ = required thickness of blade section at 0.35 of propeller radius; mm (in.)
 U_f = maximum normal distance from the moment of inertia axis to points in the face boundary (tension side) of the section; mm (in.)
 W = expanded width of a cylindrical section at the 0.25 or 0.35 radius

5.3.3 Blades of Unusual Design

Propellers of unusual design for thruster duties, such as:

- Propellers with the skew angle $\theta > 25^\circ$
- Controllable pitch propellers with skew angle $\theta > 25^\circ$
- Propellers with wide-tip blades and skew angle $\theta > 25^\circ$
- Controllable pitch propellers with wide-tip blades
- Cycloidal propellers, etc. are subject to special consideration based on submittal of propeller load and stress analyses. See 4-3-3/5.7.

5.3.4 Propeller Blade Studs and Bolts

5.3.4(a) *Area*. Studs used to secure propeller blades are to have a cross-sectional area at the minor diameter of the thread of not less than that determined by the equations in 4-3-3/5.13.2.

5.3.4(b) *Fit of studs and nuts*. Studs are to be fitted tightly into the hub and provided with an effective means for locking. The nuts are also to have a tight-fitting thread and be secured by stop screws or other effective locking devices.

5.3.5 Blade Flange and Mechanism

The strength of the propeller blade flange and internal mechanisms of controllable-pitch propellers subjected to the forces from propulsion torque is to be determined as follows:

- For intermittent duty thrusters, be at least equal to that of the blade design pitch condition.
- For continuous duty thrusters, be at least 1.5 times that of the blade at design pitch condition.

5.3.6 Blade Pitch Control

Blade pitch control system is to comply with the requirements of 4-3-3/5.15.3, as applicable.

5.5 Gears

5.5.1 Continuous Duty Gears

Gears for continuous duty thrusters are to meet the provisions of Section 4-3-1.

5.5.2 Intermittent Duty Gears

Gears for intermittent duty thrusters, as defined in 4-3-5/1.5.3, are to be in accordance with a recognized standard and are to be submitted for consideration. See e.g., Appendix 4-3-1A1.

5.7 Shafts

5.7.1 Gear Shafts

Gear and pinion shaft diameters are to be determined by the equations in 4-3-1/5.9.

5.7.2 Propeller and Line Shafts

Shafting is to be in accordance with the provisions of 4-3-2/5.1 through 4-3-2/5.17, and cardan shafts, 4-3-2/5.21.

5.7.3 Couplings and Clutches

Shaft couplings, clutches, etc. are to be in accordance with the provisions of 4-3-2/5.19.

5.9 Anti-friction Bearings

Full bearing identification and life calculations are to be submitted. Calculations are to include all gear forces, thrust vibratory loads at maximum continuous rating, etc. The minimum L10 life is not to be less than the following:

- i) Continuous duty thrusters (propulsion and dynamic positioning): 20,000 hours
- ii) Intermittent duty thrusters: 5,000 hours

Shorter life may be considered in conjunction with an approved bearing inspection/replacement program reflecting calculated life. See 4-3-4/5.9 for non-duplicated components.

5.11 Steering Systems for Vessel's Directional Control

Function of a steering mechanism is to rotate azimuthal thrusters for purpose of steering the vessel at any horizontal angles. The steering mechanism is to be capable of rotating thrusters delivering the maximum torque under all conditions.

Steering components such as pinion gears and slewing bearings are to meet the applicable requirements of Section 4-3-1, as applicable. Alternatively, consideration will be given to gears that are rated based on the recognized standards.

Hydraulic motors driving pinions for steering mechanisms are to be certified by the Surveyor at manufacturers' plants in accordance with 4-6-1/7.3.

Steering systems for azimuthal thrusters are to meet the requirements of Section 4-3-4, as applicable, and the following requirements.

5.11.1 Vessels with Only One Azimuthal Thruster

For vessels that are arranged with only one azimuthal thruster as the only means of propulsion and steering, the thruster is to be provided with steering systems of a redundant design such that a single failure in one system does not affect the other system.

5.11.2 Cargo Vessels with Two Azimuthal Thrusters

For cargo vessels that are arranged with two azimuthal thrusters as the only means of propulsion and steering, each thruster is to be provided with at least one steering system. The steering system for each thruster is to be independent of the steering system for the other thruster.

5.11.3 Passenger Vessels with Two Azimuthal Thrusters

For passenger vessels that are arranged with two azimuthal thrusters as the only means of propulsion and steering, each thruster is to be provided with steering systems of a redundant design such that a single failure in one system does not affect any other system.

5.12 Arrangements

5.12.1 Arrangements

The main steering gear arrangements for vessel's directional control is to be:

- i) Of adequate strength and capable of steering the vessel at maximum ahead service speed.
- ii) Capable of changing direction of the vessel's directional control system from one side to the other at declared steering gear angle limits at an average rotational speed of not less than $2.3^{\circ}/s$ with vessel running ahead at maximum ahead service speed.
- iii) Operated by power
- iv) Reverse direction of thrust in sufficient time, and so to bring the vessel to rest within a reasonable distance from maximum ahead service speed, shall be demonstrated and recorded.

5.12.2 Auxiliary Steering Gear Arrangements

5.12.2(a) The auxiliary steering arrangements for vessel's directional control is to be:

- i) Of adequate strength and capable of steering the vessel at navigable speed and of being brought quickly into action in an emergency;
- ii) Capable of changing direction of the vessel's directional control system from one side to the other at declared steering angle limits at an average rotational speed, of not less than $0.5^{\circ}/s$; with the vessel running ahead at one half of the maximum ahead service speed or 7 knots, whichever is the greater; and;
- iii) For all vessels, operated by power where necessary to meet the requirements of 4-3-5/5.12.2(a)ii) and in any vessel having power of more than 2,500 kW propulsion power per thruster unit.

5.12.2(b) In a vessel fitted with multiple steering systems, such as but not limited to azimuthing thrusters or water jet propulsion systems, an auxiliary steering gear need not be fitted, provided that:

- i) For a passenger vessel, each of the steering systems, is capable of satisfying the requirements in 4-3-5/5.12.1ii) while any one of the power units is out of operation;
- ii) For a cargo vessel, each of the steering systems, is capable of satisfying the requirements in 4-3-5/5.12.1ii) while operating with all power units;
- iii) Each of the steering systems is arranged so that after a single failure in its piping or in one of the power units, vessel's steering capability (but not individual steering system operation) can be maintained or speedily regained (e.g., by the possibility of positioning the failed steering system in a neutral position in an emergency, if needed). The above capacity requirements apply regardless whether the steering systems are arranged with common or dedicated power units.

5.12.3 Independent Source of Power.

Where the propulsion power exceeds 2,500 kW per thruster unit, an alternative power supply, sufficient at least to supply the steering arrangements which complies with the requirements of 4-3-5/5.12.2(a)ii) and also its associated control system and the steering system response indicator, is to be provided automatically, within 45 seconds, either from the emergency source of electrical power or from an independent source of power located in the steering gear compartment. This independent source of power is to be used only for this purpose. In every vessel of 10,000 gross tonnage and upwards, the alternative power supply is to have a capacity for at least 30 minutes of continuous operation and in any other vessel for at least 10 minutes.

5.12.4 Electric and Electrohydraulic Steering Systems

For a vessel fitted with multiple steering systems, the requirements in 4-3-4/11.1 are to be applied to each of the steering systems.

5.13 Access for Inspection

Adequate access covers are to be provided to permit inspection of gear train without disassembling thruster units.

7 Controls and Instrumentation

7.1 Control System

An effective means of controlling the thruster from the navigation bridge is to be provided. Control power is to be from the thruster motor controller or directly from the main switchboard. Propulsion thrusters are also to be fitted with local means of control.

7.3 Instrumentation

Alarms and instrumentation are to be provided in accordance with 4-3-5/Table 1, as applicable.

**TABLE 1
Instrumentation for Thrusters**

<i>Monitored Parameter</i>	<i>Navigation Bridge</i>	<i>Main Control Station^(1, 2)</i>
Engine low lubricating oil pressure alarm	x ⁽¹⁾	x
Engine coolant high temperature alarm	x ⁽¹⁾	x
Motor overload alarm	x ⁽¹⁾	x
Thruster RPM	x	x
Thrust direction (azimuthing type)	x	x
Thruster power supply failure alarm	x	x
Controllable pitch propellers hydraulic oil low pressure alarm	x ⁽¹⁾	x
Controllable pitch propellers hydraulic oil high pressure alarm	x ⁽¹⁾	x
Controllable pitch propellers hydraulic oil high temperature alarm	x ⁽¹⁾	x
Fire detection	x	x

Notes:

- 1 Either an individual indication or a common trouble alarm may be fitted at this location, provided individual indication is installed at the equipment (or main control station)
- 2 For vessels not fitted with a main control station, the indication is to be installed at the equipment or other suitable location

7.5 Failure Detection and Response

Notwithstanding 4-3-5/7.1 and 4-3-5/7.3 above, 4-3-4/13.1.9 and 4-3-4/15 for steering gear, apply.

9 Communications

A means of voice communication is to be provided between the navigation bridge, main propulsion control station and the thruster room.

11 Miscellaneous Requirements for Thruster Rooms

11.1 Ventilation

Thruster rooms are to be provided with suitable ventilation so as to allow simultaneously for crew attendance and for thruster machinery to operate at rated power in all weather conditions.

11.3 Bilge System for Thruster Compartments

Thrusters installed in normally unattended spaces are to be arranged such that bilge pumping can be effected from outside the space. Alternatively, where bilge pumping can only be effected from within the space, a bilge alarm to warn of high bilge water level is to be fitted in a centralized control station, the navigation bridge or other normally manned control station. For bilge systems in general, see 4-6-4/5.5.11.

Thrusters in enclosed modules (capsules) are to be provided with a high water level alarm. At least one pump capable of bilging the module is to be operable from outside the module.

11.5 Fire Fighting Systems

In general, spaces where thrusters are located, including enclosed modules, are to be protected with fire fighting system in accordance with 4-7-2/1.

13 Certification and Trial

13.1 Survey at the Shop of the Manufacturer

Thrusters and associated equipment are to be inspected, tested and certified by ABS in accordance with the following requirements, as applicable:

Diesel engines:	Section 4-2-1
Gas turbines:	Section 4-2-3
Electric motors:	Section 4-8-3
Gears:	Section 4-3-1
Shafting:	Section 4-3-2
Propellers:	Section 4-3-3

13.3 Sea Trial

Upon completion of the installation, performance tests are to be carried out in the presence of a Surveyor in a sea trial. This is to include but not limited to running tests at intermittent or continuous rating and maneuvering tests not to exceed the declared operational limits.

13.5 Sea Trial Results

The stopping times, vessel headings and distances recorded on trials, together with the results of trials to determine the ability of vessel's having multiple propulsion/steering arrangements to navigate and maneuver with one or more of these devices inoperative, are to be available on board for the use of the Master or designated personnel.

15 Notification of Declared Operational Limits

At each position where the directional control system can be operated, the declared operational limits are to be permanently indicated by a placard.

PART

4

CHAPTER 3 Propulsion and Maneuvering Machinery

SECTION 6 Waterjets

1 Waterjets

1.1 General

Full details are to be submitted for the force transmitting parts of waterjet units, including material specifications. For vessels over 24 m (79 ft), the units are to be manufactured under Surveys. Mill certificates are to be provided for the components of the steering section. The material tests for the impellers, shafts and couplings are to be witnessed by the Surveyor. Hydraulic cylinders are to be manufactured and inspected in accordance with the requirements of 4-6-6/3.5.5. The use of galvanically dissimilar metallic materials is to be considered in the waterjet design.

1.3 Design

Design basis stress calculations for the impellers, shafting, steering mechanism and reversing mechanism are to be submitted to substantiate the suitability and strength of component parts for the intended service. For the purpose of design review, the stress calculations are to cover the “worst case” condition for each component. The factor of safety for the above components is not to be less than 2.0 when determined by the following equation:

$$\frac{1}{FS} = \frac{S_s}{U} + \frac{S_a}{E}$$

nor less than 4.0 when determined by the following equation:

$$FS = \frac{U}{S_s}$$

where

- FS = factor of safety
- S_s = steady stress of low cycle alternating stress
- S_a = alternating stress
- U = ultimate tensile strength of material
- E = corrected fatigue strength of material (based on 10^8 cycles)

1.5 Housings

Calculations or test results to substantiate the suitability and strength of the pressure and suction housing are to be submitted for review. The condition with the inlet of the suction blocked is also to be considered. A factor of safety of not less than four based on the ultimate tensile strength of the material (or two based on the yield strength) is to be maintained at each point in the housing. Housings are to be hydrostatically tested to 1.5 times the maximum working pressure or to 3.4 bar (3.5 kgf/cm², 50 psi), whichever is greater.

1.7 Reversing Mechanisms

Astern thrust is to be provided in sufficient amounts to secure proper control of the vessel in all normal circumstances. The reversing mechanism is to provide for reversing at full power.

1.9 Impeller Bearings

Antifriction bearings are to have a B10 life of at least 80,000 hours.

PART

4

CHAPTER 3 Propulsion and Maneuvering Machinery

SECTION 7 Propulsion Redundancy

1 General

1.1 Application

The requirements in this section apply to vessels equipped with propulsion and steering systems designed to provide enhanced reliability and availability through functional redundancy. Application of the requirements of this section is optional. When a vessel is designed, built and surveyed in accordance with this section, and when found satisfactory, a classification notation, as specified in 4-3-7/3, as appropriate, may be granted.

It is a prerequisite that the vessels are also to be classed to **✕ ACCU** or **✕ ABCU** notation, in accordance with Part 4, Chapter 9.

1.3 Objective

The objective of this section is to provide requirements which reduce the risk to personnel, the vessel, other vessels or structures, the environment and the economic consequences due to a single failure causing loss of propulsion or steering capability. This is achieved through varying degrees of redundancy based upon the vessel's Classification Notations, as described in 4-3-7/3.

The requirements in this section are intended so that, following a single failure, the vessel is capable of either:

- i) Maintaining course and maneuverability at reduced speeds without intervention by other vessels, or
- ii) Maintaining position under adverse weather conditions, as described in 4-3-7/7.3, to avoid uncontrolled drift and navigating back to safe harbor when weather conditions are suitable.

In addition, this section addresses aspects which would reduce the detrimental effects to the propulsion systems due to a localized fire in the machinery spaces.

1.5 Definitions

For the purpose of this section, the following definitions are applicable:

1.5.1 Auxiliary Services System

All support systems (e.g., fuel oil system, lubricating oil system, cooling water system, compressed air and hydraulic systems, etc.) which are required to run propulsion machinery and propulsors.

1.5.2 Propulsion Machinery Space

Any space containing machinery or equipment forming part of the propulsion systems.

1.5.3 Propulsion Machine

A device (e.g., diesel engine, turbine, electrical motor, etc.) which develops mechanical energy to drive a propulsor.

1.5.4 Propulsion System

A system designed to provide thrust to a vessel, consisting of one or more propulsion machines, one or more propulsors, all necessary auxiliaries and associated control, alarm and safety systems.

1.5.5 Propulsor

A device (e.g., propeller, waterjet) which imparts force to a column of water in order to propel a vessel, together with any equipment necessary to transmit the power from the propulsion machinery to the device (e.g., shafting, gearing, etc.).

1.5.6 Steering System

A system designed to control the direction of movement of a vessel, including the rudder, steering gear, etc.

1.7 Plans and Data to be Submitted

In addition to the plans and data required by the Rules, the following are to be submitted:

- i) Results of computations showing that, upon any single failure in the propulsion and steering systems, the vessel is able to meet the capability requirements of 4-3-7/7.1, if applicable, with details of the computational methods used. Alternatively, the results of model testing are acceptable as evidence.
- ii) A Failure Mode and Effect Analysis (FMEA) or equivalent. The integrity of the propulsion systems, steering systems and auxiliary service systems is to be verified by means of a Failure Mode and Effect Analysis (FMEA) or equivalent method and is to show that a single failure will not compromise the criteria as specified in 4-3-7/7.
- iii) A Testing Plan to cover the means whereby verification of the redundancy arrangements will be accomplished.
- iv) A general arrangement detailing locations of all machinery and equipment necessary for the correct functioning of the propulsion and steering systems, including the routing of all associated power, control and communication cables. (Required for **R1-S** and **R2-S** only).
- v) Operating Manual, as required in 4-3-7/13.

3 Classification Notations

Where requested by the Owner, propulsion and steering installations which are found to comply with the requirements specified in this section and which have been constructed and installed under survey by the Surveyor may be assigned with the following class notations, as appropriate.

- i) **R1** A vessel fitted with multiple propulsion machines but only a single propulsor and steering system will be assigned the class notation **R1**.
- ii) **R2** A vessel fitted with multiple propulsion machines and also multiple propulsors and steering systems (hence, multiple propulsion systems) will be assigned the class notation **R2**.
- iii) **R1-S** A vessel fitted with only a single propulsor but having the propulsion machines arranged in separate spaces such that a fire or flood in one space would not affect the propulsion machine(s) in the other space(s) will be assigned the class notation **R1-S**.
- iv) **R2-S** A vessel fitted with multiple propulsors (hence, multiple propulsion systems) which has the propulsion machines and propulsors, and associated steering systems arranged in separate spaces (propulsion machinery space and steering gear flat) such that a fire or flood in one space would not affect the propulsion machine(s) and propulsor(s), and associated steering systems in the other space(s) will be assigned the class notation **R2-S**.

Example arrangements for each of the above notations are shown in 4-3-7/Figure 1.

- v) **+** (Plus Symbol) The mark **+** will be affixed to the end of any of the above class notations (e.g., **R1+**, **R2-S+**) to denote that the vessel's propulsion capability is such that, upon a single failure, propulsive power can be maintained or immediately restored to the extent necessary to withstand adverse weather conditions without drifting, in accordance with 4-3-7/7.3. The lack of the mark **+** after the class notation indicates that the vessel is not intended to withstand the adverse weather conditions in 4-3-7/7.3, but can maintain course and maneuverability at a reduced speed under normal expected weather conditions, in accordance with 4-3-7/7.1.

FIGURE 1
Arrangements of Propulsion Redundancy

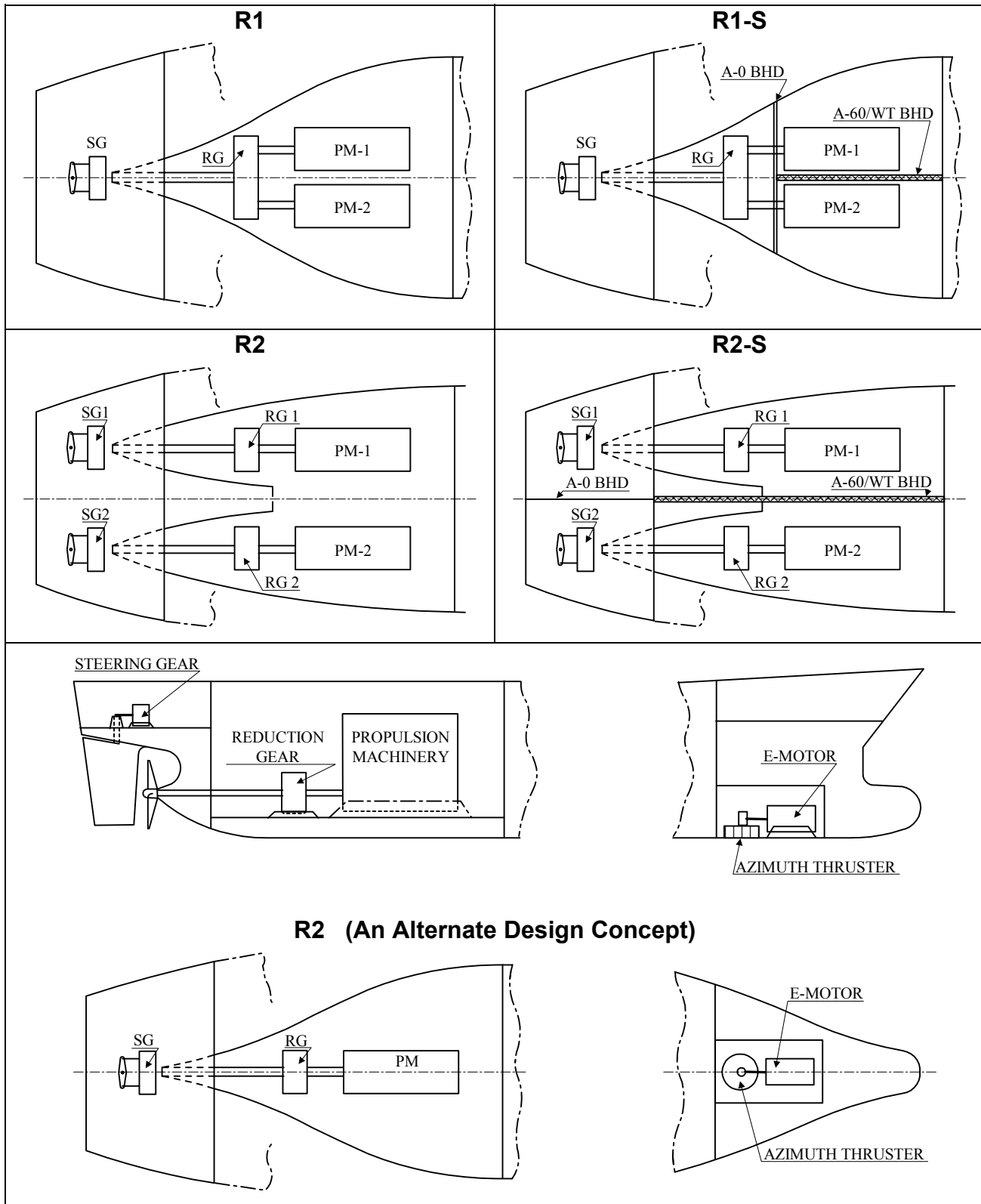

5 Single Failure Concept

The degree of redundancy required to meet the objectives of this section is based upon a single failure concept. The concept accepts that failures may occur but that only one such failure is likely at any time. The final consequence of any single failure is not to compromise the propulsion and steering capability required in 4-3-7/7, unless otherwise specified.

5.1 Single Failure Criteria

5.1.1 R1 Notation

For **R1**, the single failure criterion is applied to the propulsion machines, its auxiliary service systems and its control systems. This notation does not consider failure of the propulsor or rudder, or total loss of the propulsion machinery space or steering gear flat due to fire or flood.

5.1.2 R2 Notation

For **R2**, the single failure criterion is applied to the propulsion machines, propulsors, auxiliary service systems, control systems and steering systems. This notation does not consider total loss of the propulsion machinery space or steering gear flat due to fire or flood.

5.1.3 R1-S Notation

For **R1-S**, the single failure criterion is applied as for **R1**, but a fire or flood in one of the propulsion machinery spaces is also considered.

5.1.4 R2-S Notation

For **R2-S**, the single failure criterion is applied as for **R2**, but a fire or flood in one of the propulsion machinery spaces or steering gear flats is also considered.

7 Propulsion and Steering Capability

7.1 Vessels Without + in Class Notation

Upon a single failure, the propulsion system is to be continuously maintained or restored within two (2) minutes (for alternate standby propulsion per 4-3-7/7.3 below) such that the vessel is capable of advancing at a speed of at least one-half its design speed or seven knots, whichever is less, for at least 36 hours when the vessel is fully loaded. Adequate steering capability is also to be maintained at this speed.

7.3 Vessels with + in Class Notation

In addition to 4-3-7/7.1 above, upon a single failure, the propulsion and steering system is to be continuously maintained or immediately restored within two (2) minutes, as in the case when an alternate standby type of propulsion is provided, (e.g., electric motor, diesel engine, waterjet propulsion, etc.) such that the vessel is capable of maneuvering into an orientation of least resistance to the weather, and once in that orientation, maintaining position such that the vessel will not drift for at least 36 hours. This may be achieved by using all available propulsion and steering systems including thrusters, if provided. This is to be possible in all weather conditions up to a wind speed of 17 m/s (33 knots) and significant wave height of 4.5 m (15 ft) with 7.3 seconds mean period, both of which are acting concurrently in the same direction. The severest loading condition for vessel's maneuverability is also to be considered for compliance with this weather criterion. Compliance with these capability requirements is to be verified by computational simulations, and the detailed results are to be submitted for approval. The estimated optimum capability is to be documented in the operating manual, as required in 4-3-7/13.

9 System Design

9.1 Propulsion Machinery and Propulsors

At least two independent propulsion machines are to be provided. As appropriate, a single failure in any one propulsion machine or auxiliary service system is not to result in propulsion performance inferior to that required by 4-3-7/7.1 or 4-3-7/7.3, as applicable.

9.1.1. R1 Notation

For **R1** notation, the propulsion machines and auxiliary service systems may be located in the same propulsion machinery space and the propulsion machines may drive a single propulsor.

9.1.2. R2 Notation

For **R2** notation, at least two propulsors are to be provided such that a single failure of one will not result in propulsion performance inferior to that required by 4-3-7/7.1 or 4-3-7/7.3, as applicable. The propulsion machines and auxiliary service systems may, however, be located in the same propulsion machinery space.

9.1.3. R1-S Notation

For **R1-S** notation, the propulsion machines and auxiliary service systems are to be separated in such a way that total loss of any one propulsion machinery space (due to fire or flood) will not result in propulsion performance inferior to that required by 4-3-7/7.1 or 4-3-7/7.3, as applicable. The propulsion machines may, however, drive a single propulsor, and the main propulsion gear or main power transmitting gear is to be located outside the propulsion machinery spaces separated by a bulkhead meeting the criteria per 4-3-7/9.3.

9.1.4. R2-S Notation

For **R2-S** notation, at least two propulsors are to be provided, and the propulsion systems are to be installed in separate spaces such that a single failure in one propulsor or a total loss of any one propulsion machinery space (due to fire or flood) will not result in propulsion performance inferior to that required by 4-3-7/7.1 or 4-3-7/7.3, as applicable.

9.3 System Segregation

Where failure is deemed to include loss of a complete propulsion machinery space due to fire or flooding (**R1-S** and **R2-S** notations), redundant components and systems are to be separated by watertight bulkheads with an A-60 fire classification.

Service access doors which comply with 3-2-9/9.1 may be provided between the segregated propulsion machinery spaces. A means of clear indication of open/closed status of the doors is to be provided in the bridge and at the centralized control station. Unless specially approved by the flag Administration, these service access doors are not to be accounted for as the means of escape from the machinery space Category A required by the requirements of Regulation II-2/13 of SOLAS 1974, as amended.

9.5 Steering Systems

An independent steering system is to be provided for each propulsor. Regardless of the type and the size of vessel, each steering system is to meet the requirements of Regulation II-1/29.16 of SOLAS 1974, as amended.

The rudder design is to be such that the vessel can turn in either direction with one propulsion machine or one steering system inoperable.

For **R2-S** notation, the steering systems are to be separated such that a fire or flood in one steering compartment will not affect the steering system(s) in the other compartment(s), and performance in accordance with 4-3-7/7.1 or 4-3-7/7.3, as applicable, is maintained.

For **R2** and **R2-S** notations, in the event of steering system failure, means are to be provided to secure rudders in the amidships position.

9.7 Auxiliary Service Systems

At least two independent auxiliary service systems, including fuel oil service tanks, are to be provided and arranged such that a single failure will not result in propulsion performance inferior to that required by 4-3-7/7.1 or 4-3-7/7.3, as applicable. However, a single failure in the vital auxiliary machinery (e.g., pumps, heaters, etc.), excluding failure of fixed piping, is not to result in reduction of the full propulsion capability. In order to meet this requirement, it will be necessary to either cross-connect the auxiliary service systems and size the components (pumps, heaters, etc.) to be capable of supplying two or more propulsion machines simultaneously, or provide duplicate components (pumps, heaters, etc.) in each auxiliary system in case one fails.

With the exception of the fuel oil service tank venting system, interconnections between auxiliary service systems will be considered, provided that the same are fitted with means (i.e., valves) to disconnect or isolate the systems from each other.

For **R1-S** and **R2-S** notations, the above-mentioned independent auxiliary service systems are to be segregated in the separate propulsion machinery spaces. With the exception of fuel oil service tank venting systems, interconnections of auxiliary service systems will be acceptable, provided that the required disconnection or isolation means are fitted at both sides of the bulkhead separating the propulsion machinery spaces. Position status of the disconnection or isolation means is to be provided at the navigation bridge and the centralized control station. Penetrations in the bulkhead separating the propulsion machinery spaces and steering gear flats (as in the case of **R2-S** notation) are not to compromise the fire and watertight integrity of the bulkhead.

9.9 Electrical Distribution Systems

Electrical power generation and distribution systems are to be arranged such that following a single failure in the systems, the electrical power supply is maintained or immediately restored to the extent that the requirements in 4-3-7/7 are met.

Where the vessel's essential equipment is fed from one main switchboard, the bus bars are to be divided into at least two sections. Where the sections are normally connected, detection of a short circuit on the bus bars is to result in automatic separation. The circuits supplying equipment essential to the operation of the propulsion and steering systems are to be divided between the sections such that a loss of one section will not result in performance inferior to that defined in 4-3-7/7. A fully redundant power management system is to be provided so that each section of the switchboard can function independently.

For **R1-S** and **R2-S** notations, the ship service power generators, their auxiliary systems, the switchboard sections and the power management systems are to be located in at least two machinery spaces separated by watertight bulkheads with an A-60 fire classification. The power distribution is to be so arranged that a fire or flooding of one machinery space is not to result in propulsion capability inferior to that defined in 4-3-7/7. Where an interconnection is provided between the separate propulsion machinery spaces, a disconnection or isolation means are to be provided at both sides of the bulkhead separating the propulsion machinery spaces. Position status of the disconnection or isolation means is to be provided at the navigation bridge and the centralized control station. Fire or flooding of one machinery space is not to result in propulsion capability inferior to that defined in 4-3-7/7. The power cables from the service generator(s) in one propulsion machinery space are not to pass through the other propulsion machinery space containing the remaining service generator(s).

Additionally, for **R1-S** and **R2-S** notations, subject to approval by the Administration, the requirements for self-contained emergency source of power may be considered satisfied without an additional emergency source of electrical power, provided that:

- i) All generating sets and other required sources of emergency source of power are designed to function at full rated power when upright and when inclined up to a maximum angle of heel in the intact and damaged condition, as determined in accordance with Part 3, Chapter 3. In no case need the equipment be designed to operate when inclined more than 22.5° about the longitudinal axis and/or when inclined 10° about the transverse axis of the vessel.
- ii) The generator set(s) installed in each machinery space is of sufficient capacity to meet the requirements of 4-8-2/3 and 4-8-2/5.
- iii) The arrangements required in each machinery space are equivalent to those required by 4-8-2/5.9.1, 4-8-2/5.13 and 4-8-2/5.15, so that a source of electrical power is available at all times for the services required by 4-8-2/5.

9.11 Control and Monitoring Systems

The control systems are to be operable both independently and in combination from the bridge or the centralized control station. The mode of operation is to be clearly indicated at each position from which the propulsion machinery may be controlled.

It is to be possible to locally control the propulsion machinery and the propulsor.

For **R1-S** and **R2-S** notations, the control and monitoring system for the propulsor (e.g., controllable pitch propeller control), including all associated cabling, is to be duplicated in each space, and fire or flooding of one space is not to adversely affect operation of the propulsor from the other space.

9.13 Communication Systems

The requirements of 4-8-2/11.5 are to be complied with for all installed propulsion control positions.

For **R1-S** and **R2-S** notations, the communications cables to each control position are not to be routed through the same machinery space.

11 Fire Precautions

The requirements of this section apply to Category A machinery spaces only.

For **R1** and **R2** notations, the following requirements are to be complied with in order to minimize the risk of common damage due to a localized fire in the machinery space.

- i) Each auxiliary services system is to be grouped and separated as far as practicable.
- ii) Electrical cables supplying power to redundant equipment are to exit the switchboard and be routed to the equipment, as far apart as practicable.

13 Operating Manual

An operating manual, which is consistent with the information and criteria upon which the classification is based, is to be placed aboard the vessel for the guidance of the operating personnel. The operating manual is to give clear guidance to the vessel's crew about the vessel's redundancy features and how they may be effectively and speedily put into service in the event that the vessel's normal propulsion capability is lost. The operating manual is to include the following, as a minimum:

- i) Vessel's name and ABS ID number
- ii) Simplified diagram and descriptions of the propulsion systems in normal condition
- iii) Simplified diagram and descriptions of the propulsion redundancy features
- iv) Reduced propulsion capability in terms of estimated worst sea-states which the vessel may withstand without drifting (for vessels with + in the Class Notation)
- v) Test results for the vessel's maneuverability at reduced speed (for vessels without + in the Class Notation).
- vi) Step-by-step instructions for the use of the redundancy features
- vii) Description of the communication systems
- viii) Detailed instructions for local propulsion machinery control

The operating manual is to be submitted for review by ABS solely to verify the presence of the above information, which is to be consistent with the design information and limitations considered in the vessel's classification. ABS is not responsible for the operation of the vessel.

Any modifications made to the existing propulsion systems are to be approved by ABS. The operating manual is to be updated accordingly and submitted to ABS for review.

15 Test and Trial

During the sea trial, the propulsion and steering capability are to be tested in accordance with an approved test program to verify compliance with this section.

15.1 Fault Simulation Test

Simulation tests for the redundancy arrangements are to be carried out to verify that, upon any single failure, the propulsion and steering systems remain operational, or the back-up propulsion and steering systems may be speedily brought into service.

15.3 Communication System Test

The effectiveness of the communication systems, as required in 4-3-7/9.13 above, is to be tested to verify that local control of the propulsion systems may be carried out satisfactorily.

17 Survey After Construction

The surveys after construction are to be in accordance with the applicable requirements as contained in the *ABS Rules for Survey After Construction (Part 7)*.

PART

4

CHAPTER 3 Propulsion and Maneuvering Machinery

SECTION 8 Podded Propulsion Units

1 General

1.1 Application

The requirements in this Section apply to vessels equipped with propulsion and steering systems based on installation of podded electrical propulsion units.

1.3 Scope

Unless specifically stipulated otherwise in this Section, podded electrical propulsion systems are to comply with the relevant sections of these Rules, which include the following Chapters.

- Part 4, Chapter 3 Propulsion and Maneuvering Machinery
- Part 4, Chapter 6 Piping Systems
- Part 4, Chapter 8 High Voltage Systems, see 4-8-5/3
- Part 4, Chapter 8 Electrical Propulsion Systems, see 4-8-5/5
- Part 4, Chapter 9 Remote Propulsion Control and Automation

1.5 Notations

1.5.1 **⊠ AMS or AMS**

Machinery for main propulsion, which complies with the propulsion requirements of these Rules (as applicable) and this Section, will be distinguished in the *Record* by the symbol **⊠ AMS** or **AMS** in accordance with 1-1-3/13 or 1-1-3/15, as appropriate.

1.5.2 **⊠ ACC, ACC, ⊠ ACCU, ACCU, ⊠ ABCU or ABCU**

Remote, centralized or automatic control systems for main propulsion units or essential auxiliaries which complies with the requirements of Part 4, Chapter 9 (as applicable) and this Section, will be distinguished in the *Record* by the symbol **⊠ ACC, ACC, ⊠ ACCU, ACCU, ⊠ ABCU, or ABCU** in accordance with 1-1-3/17 and 4-9-1/3, as appropriate.

1.7 Design Requirements

1.7.1 Redundancy

Where the propulsion system comprises a single pod propulsor, a detail risk analysis is to be carried out in a form of FMEA (Failure Modes and Effects Analysis) or other effective methodology in order to ascertain that the system is fault-tolerant. The analysis is to be conducted by the pod manufacturer, and is to be submitted for review.

1.7.2 Pod Performance Requirements

Structural and mechanical designs of the pod propulsor are to be based on ship's all operating conditions, including normal maneuvering conditions at full navigating speed and emergency astern maneuvering conditions.

1.7.3 Pod Shaft Vibration Analysis

Torsional and lateral vibration analysis covering all operating speeds is to be carried out by the pod manufacturer, and is to be submitted for review.

1.7.4 Ambient Conditions

The cooling arrangements of the pod propulsor are to consider the machinery and equipment operating at the maximum continuous rating and apply the ambient air temperature of 45°C (113°F) and ambient sea water temperature of 32°C (89.6°F) indicated in 4-1-1/7.11 and 4-1-1/Table 8. If the machinery and equipment within the podded propulsion unit will be exposed to higher ambient conditions, then the machinery and equipment are to be suitable for operation without degraded performance at the maximum expected air temperature or sea water temperature.

3 Definitions

Pod. A pod (or podded propulsion unit) is a propulsion unit with a prime mover (typically an electric motor) on the same shaft as the propeller. The propulsion unit along with some of the auxiliary machinery is typically located outside of the vessel's hull structure. The propulsion unit is typically capable of operation similar to an azimuthal thruster.

Azimuthal thruster. A thruster that is capable of rotation through 360 degrees so that thrust can be developed in any direction.

Propulsion unit. A thruster or podded propulsion unit that is assigned to provide the propulsion of a vessel.

Rules. The applicable edition of the *ABS Rules for Building and Classing Marine Vessels*.

5 Plans to be Submitted

5.1 Plans to be submitted

General arrangement drawings indicating the key principal dimensions, detailed drawings and documents showing the following information are to be submitted:

- Bearing arrangements
- Sealing arrangements, exposed to the sea
- Bilge system drawings
- Drawings of the steering systems (including control systems for steering systems)
- Piping drawings for lube oil, hydraulic systems, ventilation and cooling system)
- Electrical drawings for electric motor and drawings indicating the power supply from the generators, switchboards, transformers, converters, through to the electric motor
- Drawings for the Propulsion Control and Automation
- Failure Modes and Effects Analysis (FMEA) or other equivalent risk analysis to demonstrate a single failure does not lead to total loss of all propulsion and/or steering capability
- Test Plan, see 4-3-8/17.1
- For specific requirements of pod structure, refer to 3-2-14/25

5.3 Information to be Submitted

The following information is to be submitted

- Material grades for plates and sections
- Chemical and mechanical properties for forgings and castings
- Supporting calculations for the interface between the hull structure and the podded propulsion unit (a finite element calculation would be considered an appropriate method)

- The manufacturer's limits on the seating flatness of the slewing ring
- The maximum anticipated service loads are to be provided, see 4-3-8/7
- Evidence is to be provided to show that a single failure of the slewing ring would not lead to substantial flooding of the vessel
- Details of piping system components
- Details of electrical and control system components
- Details of installed condition monitoring equipment
- Detailed list of hazardous atmospheric conditions including the maximum operating air temperature inside the pod.

7 Global Loads

The review of the podded propulsion unit is to be based on the maximum anticipated service loads. These loads are to take the following into account:

- All dynamic effects (including slewing and ship motions)
- Lift
- Drag
- Thrust (applied propulsive loads)
- Full range of inflows (for podded propulsion units fixed about the Z-axis only)

The maximum anticipated service loads are to be provided by the designer and to be determined by recognized acceptable methods.

The following moments and forces for the maximum anticipated service loads, and the operating conditions at which they occur, are to be indicated on the drawings to be submitted for review:

- F_x , force in the longitudinal direction
- F_y , force in the transverse direction
- F_z , force in the vertical direction
- M_x , moment at the slewing ring about the pod unit's global longitudinal axis
- M_y , moment at the slewing ring about the pod unit's global transverse axis
- M_z , moment at the slewing ring about the pod unit's global vertical axis

The directions of the axes X, Y & Z and the position of the center of rotation are given in 4-3-8/Figure 1 below.

Where the maximum of angle of rotation is limited by the control system at particular speeds this may be taken into consideration when determining the loads and associated forces.

FIGURE 1
Podded Propulsion Unit

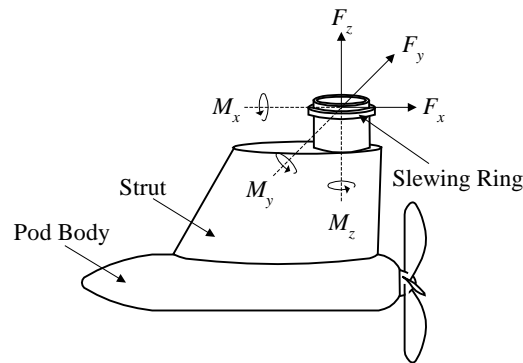

9 Structures

The structural requirements associated with the podded propulsion units are listed in 3-2-14/25.

11 Machinery and Systems

In general, the machinery and systems associated with the podded propulsion unit, and not listed in 4-3-8/11, are to meet Part 4.

11.1 Seals

The shaft seal is to be of redundant design based on double failure criteria.

11.3 Bilge pumping System

Means are to be provided that allow pumping out water entered into the pod interior space. For vessels where a single pod propulsor is installed, two independent bilge systems are to be provided.

11.5 Pod Shaft Bearing

Bearing lifetime calculation in accordance with ISO 281 is to be submitted for review. In general, the shaft bearing design is to be based on the bearing lifetime L_{10mh} of 65,000 hours. Loading profile of the bearing used for the calculation is to be indicated in the calculations. Proposals for the use of a bearing with lifetime L_{10mh} less than 65,000 hours will be considered on application with details of alleviating factors and supporting documentation. However, the bearing lifetime L_{10mh} must exceed the 5-years time between surveys; see 7-2-1/13.1.3.

11.7 Lubricating System

Each pressurized lubricating oil system, essential for operation of the pod propulsor, is to be provided with at least two lubricating oil pumps. The capacity of the pumps, with any one pump out of service, is to be sufficient for continuous operation at rated power. For multiple pod propulsor unit installation, one or more independently driven standby pumps may be provided such that all units can be operated at rated power in the event of any one lubricating oil pump for normal service being out of service.

Lube oil filters are to be of magnetic type and so arranged that they can be serviced without interrupting the pod operation.

Arrangements are to be provided so that lube oil samples can be taken for the purpose of detecting particle contamination and possible signs of bearing failure. The arrangements are to be such that the samples can be taken without interrupting the pod operation. However, where an oil-debris monitoring system required in 4-3-8/15.9.2 is provided, the lubricating oil sampling arrangement need not be provided.

11.9 Steering Systems

Steering systems for podded propulsion units are to meet the requirements of Section 4-3-4, as applicable, and the following requirements.

11.9.1 Podded Units Redundancy

In general, the following pod components are to be of redundant design:

- i) Propulsion motor rotor and stator windings
- ii) Pod steering mechanism
- iii) Heat dissipation ventilation and cooling systems for the pod interior space

Where the propulsion system consists of a single pod propulsion unit, a detailed Failure Modes and Effects Analysis (FMEA) or other equivalent risk analysis is to be required to demonstrate the system is fault-tolerant.

11.9.2 Torque Limitations

Where other than the hydraulic type steering arrangements are provided, means are to be provided to limit the maximum torque to which the steering arrangement may be subjected.

11.9.3 Podded Units Performances

Where vessels are arranged with two and more podded propulsion units, means are to be provided to lock each pod unit's slewing mechanism in its center (neutral) position in the event of a steering system failure. Such arrangements are to be adequately design to keep the pod in position at the vessels maneuvering speed which is to be not less than 7 knots. Then securing arrangement is to be outlined in the Operating Manual.

11.11 Ventilation and Cooling

An effective ventilation system is to be provided for the interior space of the pod propulsor. The ventilation system is to comprise at least two ventilation fans such that with one fan in reserve the other fan is capable of maintaining the temperature of the pod interior space below the design temperature of the motor.

Where water cooling is used, the cooler is to be so arranged to avoid entry of water into the machine, whether through leakage or condensation in the heat exchanger.

The ventilation and cooling systems are to maintain the machinery and equipment installed within the pod within the temperatures for which they were designed to operate.

For a pod propulsor having an electric propulsion motor without a forced ventilation and cooling system, heat balance calculation for the podded unit and associated machinery and equipment is to be submitted for review, to confirm satisfactorily functioning in all operating conditions.

13 Electrical

In general, the electrical equipment and systems associated with the podded propulsion unit are listed in Part 4, Chapter 8.

13.1 Description of System

For the purposes of the electric propulsion system requirements, an integrated electric propulsion system is a system where a common set of generators supply power to the vessel service loads as well as the propulsion loads.

13.3 Generating Capacity

For vessels with an integrated electric propulsion system, under normal sea-going conditions, when one generator is out of service, the remaining generator capacity is to be sufficient to carry all of the vessel services (essential services, normal services and for minimum comfortable conditions of habitability) and the propulsion loads to provide for a speed of not less than 7 knots or one half of the design speed, whichever is the lesser.

15 Propulsion Control and Automation

Each podded propulsion unit is to be provided with remote propulsion control, local propulsion control and automation, so that the podded propulsion unit can be effectively controlled and monitored. Refer also to Part 4, Chapter 9 on Remote Propulsion Control and Automation.

15.1 Local Control

The local propulsion control location is to be provided with an effective means of controlling the podded propulsion unit, including thrust, steering and the necessary auxiliary machinery (such as lube oil systems, cooling systems, etc.). Failure of remote control systems are not to interfere with the effective means of local propulsion control. Automation signals for control, monitoring and alarming are to be available at the local propulsion control location, even after failure of the remote control systems.

15.3 Remote Shutdown

Means to stop each podded propulsion unit, independent of the control system for the podded propulsion unit, is to be provided at each location that can remotely control the podded propulsion unit.

15.5 Control Systems for Steering Systems

The control systems and instrumentation for the steering systems for each podded propulsion unit are to meet the requirements of 4-3-4/13 and 4-3-4/15.

15.7 Position Indicators

Each podded propulsion unit is to be arranged with the angular position indicator located on the navigating bridge, at each maneuvering station and locally at the unit. The angular position indication is to be independent of the steering control system.

15.9 Alarms and Monitoring Systems

15.9.1 Water Ingress Alarm System

Effective means of monitoring water ingress into the pod interior space is to be provided at the machinery control station(s).

15.9.2 Shaft Bearing Monitoring

Permanent means of continuous monitoring of shaft system vibration, or alternatively, a continuous oil-debris monitoring system to detect the passage of metallic particles in the bearing lubricating oil lines is to be provided at the machinery control station(s) in order to detect early sign of pod shaft bearing deterioration. Where an oil-debris monitoring system is provided, a detector of the system is to be fitted at the outlet of the bearing lubricating oil line before entering the filters.

15.9.3 Monitoring of Temperature of the Pod Interior Space

The temperature of the pod interior space is to be monitored, and any abnormal rise of the temperature is to be alarmed at the machinery control station(s).

15.11 Instrumentation

Alarms and instrumentation are to be provided in accordance with the alarms and instrumentation for thrusters, see 4-3-5/7.3 and 4-3-5/7.5, as applicable. The azimuth angle of the podded propulsion unit is to be indicated as the thrust direction. In addition, the alarms and instrumentation in 4-3-8/Table 1 are to be provided.

TABLE 1
Podded Propulsion Instrumentation

<i>Monitored Parameter</i>	<i>Navigation Bridge</i>	<i>Main Control Station^(1, 2)</i>
Motor low lubricating oil pressure alarm	x ^(1, 3)	x
Motor high lubricating oil temperature alarm	x ⁽¹⁾	x
Motor low lubricating oil tank level alarm	x ⁽¹⁾	x
Motor coolant air inlet high temperature alarm	x ^(1, 4)	x ⁽⁴⁾
Motor coolant air outlet high temperature alarm	x ^(1, 4)	x ⁽⁴⁾
Motor low coolant air flow alarm	x ^(1, 4)	x ⁽⁴⁾
Pod interior space high temperature	x ⁽¹⁾	x
High bilge level	x ⁽¹⁾	x
Excessive or frequent bilge pump operation	x ⁽¹⁾	x
Shaft Bearings Monitoring	-	x
Electrical system alarms (See Section 4)	x	x
Angular position of each podded propulsion unit	x	x

Notes:

- 1 Either an individual indication or a common trouble alarm may be fitted at this location, provided individual indication is installed at the equipment (or main control station)
- 2 For vessels not fitted with a main control station, the indication is to be installed at the equipment or other suitable location
- 3 Applicable only where pressurized lubricating oil system is fitted
- 4 Applicable only where air cooling system is fitted

17 Testing and Trials

17.1 Test Plan

A Test Plan is to be developed for each podded propulsion unit and is to be submitted to the ABS office responsible for performing the plan review at the start of the plan review process. Copies of the test plan are to be submitted to the ABS Surveyor office responsible for witnessing the tests and trials for the vessel, prior to performing any tests or trials. The test plan is to identify all equipment and systems within the pod and the recommended method of performing the tests or trials, taking into account that some tests or trails may have to occur earlier, since the equipment or system may not be completely accessible at the sea trials for the vessel.

17.3 Testing and Trials

Testing is to be performed according to the Test Plan and as deemed necessary by the Surveyor responsible for witnessing the tests and trails for the vessel. Testing is to be performed at the podded propulsion unit's plant of manufacture when possible, particularly when the equipment or system will not be easily accessible at the sea trials for the vessel and is to be agreed to by the Surveyor responsible for witnessing the tests and trials for the vessel. Certain tests may be performed by a different Surveyor, provided it is agreed to by the Surveyor responsible for witnessing the tests and trials for the vessel.

PART

4

CHAPTER 3 Propulsion and Maneuvering Machinery

SECTION 9 Contrarotating Propellers

1 General

1.1 Application

Contrarotating propeller units having a rated power of 100 kW (135 hp) and over, intended for propulsion or for auxiliary services essential for propulsion, maneuvering and safety (see 4-1-1/1.3) of the vessel, are to be designed, constructed, certified and installed in accordance with the provisions of this section.

Contrarotating propeller systems having a rated power less than 100 kW (135 hp) are not required to comply with the provisions of this Section but are to be designed, constructed and equipped in accordance with good commercial and marine practice. Acceptance of such systems will be based on the manufacturer's affidavit, verification of nameplate data and subject to a satisfactory performance test after installation conducted in the presence of the Surveyor.

1.3 Basic Principles

Contrarotating propeller systems may be designed using either of two arrangements:

One arrangement consists of a gear to effect opposing rotation between the two shafts, shafting and two propellers of opposite hand. The gear divides the power provided by the prime mover to the two propulsion shafts which rotate in opposite directions with one of the shafts rotating inside the bore of the other shaft. The outer shaft drives the forward propeller while the inner shaft drives the after propeller.

Another arrangement consists of two prime movers arranged in line such that the propulsion shaft from the forward prime mover rotates inside the hollow propulsion shaft of the after prime mover.

For either arrangement discussed the contra-rotating aftermost propeller is designed to recover rotational energy from the slipstream shed from the forward propeller and convert to additional thrust.

1.5 Definitions

Definitions pertaining to the various components and subsystems of a contra-rotating propeller system are listed as follows:

- Gears, see 4-3-1/1.3.
- Shafting, see 4-3-2/1.3.
- Propellers, see 4-3-3/1.3.

1.9 Plans and Particulars to be Submitted

Plans and particulars to be submitted for review are listed as follows:

- Gears, see 4-3-1/1.5.
- Shafting, see 4-3-2/1.5.
- Propellers, see 4-3-3/1.5.

3 Materials

Material requirements and testing for the various components and subsystems are to be in accordance with the following:

- Gears, see 4-3-1/3
- Shafting, see 4-3-2/3
- Propellers, see 4-3-3/3

5 Design

5.1 Gears

The gear design is to be in accordance with the requirements in 4-3-1/5.

5.1.1 Gears with Multiple Prime Mover Inputs/Multiple Outputs

For single helical gears with arrangements utilizing multiple prime mover inputs, and multiple outputs (e.g. the contrarotating shafts), the following analyses for all operating modes are to be conducted:

- All bearing reactions
- Tooth modifications
- Load distributions on the gear teeth
- Contact and tooth root bending stresses

A summary of the results of these analyses for each operating mode is to be submitted for review.

5.3 Shaft Diameters

The shaft design is to be in accordance with the requirements of 4-3-2/5.

5.3.1 Alternative Criteria

As an alternative to the design equations shown in 4-3-2/5.1 and 4-3-2/5.3, shafting design may be considered for approval on the basis of axial and torsional loads to be transmitted, bending moment and resistance against fatigue. A detailed stress analysis showing a factor of safety of at least 2.0 for fatigue failure is to be submitted for approval with all supporting data.

5.5 Propeller-end Seals

Effective means are to be provided to prevent water having access to either shaft at the part between the after end of the liner and the propeller hub on the outer shaft forward propeller and between the inner shaft and outer shaft and the after propeller hub and inner shaft.

5.7 Couplings and Clutches

The requirements for the following components, if installed are:

- Demountable couplings, see 4-3-2/5.19.4
- Flexible couplings, see 4-3-2/5.19.5
- Clutches, see 4-3-2/5.19.6
- Clutches intended for use in propulsion shafting are to be of an approved design
- Locking arrangements, see 4-3-2/5.19.7
- After assembly, all coupling bolts and associated nuts are to be fitted with locking arrangement

5.9 Propulsion Shaft Vibrations

Torsional vibration calculations are to be submitted in accordance with 4-3-2/7.5 and for axial vibrations or lateral vibrations in accordance with 4-3-2/7.7 and 4-3-2/7.9 respectively.

Additional torsional vibration calculations are to be performed for shaft arrangements where the contra-rotating shafts are coupled through a gear. The calculations are to confirm for the two modes of operation when either the forward or the after propeller is isolated from the prime mover the shafting is free from the deleterious effects of torsional vibrations.

5.11 Propellers

The propeller designer is to provide the power absorbed at rated speed for both propellers. The propellers are to be designed in accordance with the requirements of 4-3-3/5.

Arrangements are to be provided in the event of damage to either propeller or failure of one of the prime movers' auxiliary functions to be isolated from the propulsion system to permit the remaining propeller to continue to function.

5.13 Access for Inspection

Adequate access covers are to be provided to permit inspection of gear train without disassembling contra-rotating propeller unit.

5.15 Shaft Alignment

The alignment and each bearing load relative to the inner and outer shafts are dependent upon one another. An evaluation is to be submitted for the shafting system taking into consideration relative inclining angle between the inner and outer shafts, additional stresses in the shafting system resulting from the shaft alignment in relation to the location and spacing of the shaft bearings, See 4-3-2/7.

5.17 Shaft Lubrication

The lubrication system is to be designed to provide all bearings, gear meshes and other parts requiring lubrication oil with an adequate amount of oil for both lubrication and cooling purposes. This is to be maintained under all operating conditions.

5.17.1 Anti-friction Bearings

If anti-friction bearings are installed, bearing lifetime calculations are to be submitted for review. In general, the bearing design is to be based on the bearing lifetime of 65,000 hours. Loading profile of the bearing used for the calculation is to be indicated in the calculations. The bearing lifetime must exceed the 5-years time between surveys; see 7-2-1/13.1.3.

5.17.2 Oil-lubricated Bearings

If oil-lubricated bearings are installed, load carrying capacity calculations for white metal bearings are to be submitted or bearing lifetime calculations are to be submitted for roller bearings or similar. In general, the bearing design is to be based on the bearing lifetime of 65,000 hours. Loading profile of the bearing used for the calculation is to be indicated in the calculations. The bearing lifetime must exceed the 5-years time between surveys; see 7-2-1/13.1.3.

5.17.3 Oil-lubricating System Sampling Arrangements

An arrangement for readily obtaining accurate oil samples is to be provided. The sampling point is to be taken from the lowest point in the oil lubricating system, as far as practicable. Also, the arrangements are to be such as to permit the effective removal of contaminants from the oil lubricating system.

5.19 Propeller Fitting

The requirements for propellers fitted to the tail shaft by a keyed fitting are in 4-3-3/5.15.1.

5.19.1 Bolted to Tail Shaft

For propellers whose attachment method to the tail shaft is by a bolted connection, calculations are to be submitted for review. The strength of the bolted connection subjected to the forces from propulsion torque is to be at least 1.5 times that of the blade at design pitch conditions.

5.19.2 Keyless Fitting

For propellers whose attachment method to the tail shaft is by a keyless fitting refer to 4-3-3/5.15.2. In addition, for the tail shaft supporting the forward propeller, calculations are to be submitted for review to verify stresses on the shaft inner surface do not exceed 70% of the minimum specified yield strength.

7 Controls and Instrumentation

The forward and aft propellers are to be provided with arrangements to be isolated from their power source. The power source may be a single unit or multiple units.

Individual visual and audible alarms are to be provided at the engine room control station to indicate:

- i) Rpm for inner and outer shafts
- ii) Lubricating oil pressure
- iii) Lubricating oil tank low level
- iv) High temperature lubricating oil
- v) High bearing temperature for bearings inner shaft bearings and outer shaft bearings
 - a) For journal bearing arrangements, high bearing temperature for both the inner shaft bearings and outer shaft bearings, or
 - b) For anti-friction bearing (roller bearing) arrangements, high contamination level of metal particles in the lubricating oil for inner shaft roller bearings.

Control, monitoring and alarms are to be provided for local manual control and at the centralized control station. If **ACC** or **ACCU** notation is requested, remote control is to be provided on the navigation bridge as per Sections 4-9-5 and 4-9-6, as applicable.

9 Certification and Trial

Contrarotating propeller units and associated equipment are to be inspected, tested and certified by ABS in accordance with the following requirements, as applicable:

- Diesel engines: Section 4-2-1
- Gas turbines: Section 4-2-3
- Electric motors: Section 4-8-3
- Gears: Section 4-3-1
- Shafting: Section 4-3-2
- Propellers: Section 4-3-3

Upon completion of the installation, performance tests are to be carried out in the presence of a Surveyor in a sea trial. This is to include but not limited to running tests at intermittent or continuous rating, vessel turning tests and vessel maneuvering tests. The gear design is to be in accordance with the requirements in 4-3-1/5.

CHAPTER 4 Boilers, Pressure Vessels and Fired Equipment

CONTENTS

SECTION 1	Boilers and Pressure Vessels and Fired Equipment	364
1	General	364
1.1	Application.....	364
1.3	Definitions.....	365
1.5	Recognized Codes or Standards.....	365
1.7	Grouping of Boilers and Pressure Vessels	366
1.9	Certification	366
1.11	Special Cases	367
1.13	Plans and Data to be Submitted.....	368
3	Materials.....	369
3.1	Permissible Materials	369
3.3	Permissible Welding Consumables	369
3.5	Material Certification and Tests	370
5	Design.....	370
7	Fabrication, Testing and Certification	370
7.1	Material Tests.....	370
7.3	Welded Fabrication	370
7.5	Dimensional Tolerances.....	370
7.7	Nondestructive Examination.....	370
7.9	Preheat and Postweld Heat Treatment	371
7.11	Hydrostatic Tests.....	371
7.13	Manufacturer's Documentation.....	371
9	Boiler Appurtenances.....	371
9.1	Safety Valves	371
9.3	Permissible Valve Connections on Boilers	373
9.5	Steam and Feed Valves.....	374
9.7	Instrument Connections for Boilers	374
9.9	Miscellaneous Connections.....	375
9.11	Inspection Openings.....	376
9.13	Dampers.....	376
9.15	Guidance for Spare Parts.....	376
9.17	Additional Requirements for Shell Type Exhaust Gas Economizers.....	376
11	Boiler Control	377
11.1	Local Control and Monitoring.....	377
11.3	Manual Emergency Shutdown.....	377
11.5	Control of Fired Boilers.....	377
11.7	Control for Waste Heat Boilers	379
11.9	Control for Fired Water Heaters	380

13	Thermal Oil Heaters.....	380
13.1	Appurtenances	380
13.3	Thermal Oil Heater Control.....	380
13.5	Exhaust-gas Thermal Oil Heaters.....	381
15	Incinerators	382
15.1	Local Control and Monitoring.....	382
15.3	Emergency Shutdown.....	382
15.5	Automatic Shutdowns.....	382
17	Pressure Vessel and Heat Exchanger Appurtenances	382
17.1	Pressure Relief Valve	382
17.3	Inspection Openings	383
17.5	Drain.....	383
19	Installation and Shipboard Trials	383
19.1	Seating Arrangements.....	383
19.3	Boiler Installation	383
19.5	Installation of Thermal Oil Heaters and Incinerators.....	384
19.7	Shipboard Trials.....	384
TABLE 1	Pressure Vessels Covered in Part 4, Chapter 4	364
TABLE 2	Grouping of Boilers and Pressure Vessels	366
TABLE 3	Certification Details	367
TABLE 4	List of Alarms and Shutdowns – Fired Boilers	378
TABLE 5	List of Alarms – Waste Heat Boilers	379
TABLE 6	List of Alarms and Shutdowns – Fired Water Heaters.....	380
TABLE 7	List of Alarms and Shutdowns – Fired Thermal Oil Heaters.....	381
TABLE 8	List of Alarms and Shutdowns – Exhaust-gas Thermal Oil Heaters.....	382

SECTION 1	Appendix 1 – Rules for Design.....	385
1	General	385
1.1	Application	385
1.3	Loads Other than Pressure.....	385
1.5	Deformation Testing	385
1.7	Plate and Pipe Thickness Tolerance	385
3	Cylindrical Shell Under Internal Pressure	385
3.1	General Equations.....	385
3.3	Boiler Shells.....	386
3.5	Pressure Vessel Shells.....	390
5	Unstayed Heads	390
5.1	Torispherically and Hemispherically Dished Heads	390
5.3	Ellipsoidal Heads	391
5.5	Heads with Access Openings	392
5.7	Unstayed Flat Heads	392
5.9	Stayed Flat Heads	399

7	Openings and Reinforcements	401
7.1	General.....	401
7.3	Reinforcement Requirements.....	402
7.5	Reinforcement Limits.....	404
7.7	Metal Having Reinforcement Value	404
7.9	Strength of Reinforcement.....	406
7.11	Reinforcement of Multiple Openings	407
9	Boiler Tubes.....	408
9.1	Materials.....	408
9.3	Maximum Allowable Working Pressure	408
9.5	Tube-end Thickness	409
9.7	Tube-end Projection	409
11	Joint Designs	409
13	Joint and Dimensional Tolerances.....	409
15	Weld Tests	409
17	Radiography and Other Nondestructive Examination	409
19	Preheat and Postweld Heat Treatment.....	410
21	Hydrostatic Tests	410
21.1	Boilers	410
21.3	Pressure Vessels	410
TABLE 1	Joint Efficiencies for Welded Joints	411
TABLE 2	(SI units) Maximum Allowable Stress Values for Ferrous Materials – N/mm ²	412
TABLE 2	(MKS units) Maximum Allowable Stress Values for Ferrous Materials – kgf/mm ²	413
TABLE 2	(US units) Maximum Allowable Stress Values for Ferrous Materials – ksi.....	414
FIGURE 1	Example of Tube Spacing With Pitch of Holes Equal in Every Row.....	387
FIGURE 2	Example of Tube Spacing with Pitch of Holes Unequal in Every Second Row	387
FIGURE 3	Example of Tube Spacing with Pitch of Holes Varying in Every Second Row	387
FIGURE 4	Example of Tube Spacing with Tube Holes on Diagonal Lines.....	387
FIGURE 5	Diagram for Determination of Diagonal Efficiency	388
FIGURE 6	Diagram for Determining Efficiency of Diagonal Ligaments in Order to Obtain Equivalent Longitudinal Efficiency.....	389
FIGURE 7	Some Acceptable Types of Unstayed Heads and Covers.....	394
FIGURE 8	Example of Reinforced Opening	401
FIGURE 9	Chart for Determining Value of <i>F</i>	403
FIGURE 10	Load-carrying Paths in Welded Nozzle Attachments.....	407
FIGURE 11	Illustration of Rules Given in 4-4-1A1/7.11.3	408

PART

4

CHAPTER 4 Boilers, Pressure Vessels and Fired Equipment

SECTION 1 Boilers and Pressure Vessels and Fired Equipment

1 General

1.1 Application

Regardless of the system in which they formed a part, boilers, fired and unfired heaters, pressure vessels and heat exchangers of the following categories are to be subjected to the provisions of this section:

- i)* Boilers and steam generators with design pressure over 3.5 bar (3.6 kgf/cm², 50 psi).
- ii)* Fired heaters for oil with design pressure over 1 bar (1 kgf/cm², 15 psi).
- iii)* Independent pressure vessel tanks for the carriage of liquefied gases, defined in Section 5C-8-4.
- iv)* Welded accumulators, regardless of their diameters, see 4-6-7/3.5.4.
- v)* Accumulators of extruded seamless construction are to be designed, manufactured and tested in accordance with a recognized standard for this type of pressure vessel, see 4-6-7/3.5.4.
- vi)* Other pressure vessels and heat exchangers of 150 mm (6 in.) diameter and over, having design pressure, temperature and volume as defined in 4-4-1/Table 1. Pressure vessels and heat exchangers under 150 mm (6 in.) in diameter are not required to comply with the provisions of this section. Acceptance of them will be based on manufacturer's guarantee of physical properties and suitability for the intended service, provided the installation is carried out to the satisfaction of the Surveyor.
- vii)* Boilers and fired heaters not included above, fired inert gas generators and incinerators are subject to the provisions of 4-4-1/15 only.

TABLE 1
Pressure Vessels Covered in Part 4, Chapter 4

	Pressure				Temperature			Volume		ABS Type Appr. Tier	Rule Reference
	bar	kgf/cm ²	psi		°C	°F		m ³	ft ³		
a) Pressure vessels and heat exchangers for toxic and corrosive substances (see 4-1-1/1.9.5)	>1.0	>1.0	>15	–	all	all	–	all	all	5	4-4-1/1.9
b) Pressure vessels, heat exchangers and heaters other than a)	>6.9	>7	>100	–	all	all	–	all	all	4/5	4-4-1/1.9
c) Pressure vessels, heat exchangers and heaters other than a) and b)	>1.0	>1.0	>15	and	>149 ⁽¹⁾ >66 ⁽²⁾ >90 ⁽³⁾	>300 ⁽¹⁾ >150 ⁽²⁾ >200 ⁽³⁾	and	>0.14	> 5	4/5	4-4-1/1.11.2, 4-4-1/1.5

Notes

- 1 Applicable to steam, gas or vapor; and to liquids other than fuel oil, lubricating oil, hydraulic oil and thermal oil.
- 2 Applicable to fuel oil.
- 3 Applicable to lubricating oil, hydraulic oil and thermal oil.

1.3 Definitions

1.3.1 Design Pressure

Design Pressure is the gauge pressure to be used in the design of the boiler or pressure vessel. It is to be at least the most severe condition of coincidental pressure and temperature to be expected in normal operation. For pressure vessels having more than one chamber, the design pressure of the inner chamber is to be the maximum difference between the inner and outer chambers.

1.3.2 Maximum Allowable Working Pressure

The *Maximum Allowable Working Pressure* (MAWP) of a boiler or pressure vessel is the maximum pressure permissible at the top of the boiler or pressure vessel in its normal operating condition and at the designated coincidental temperature specified for that pressure. It is the least of the values found for MAWP for any pressure-bearing parts, adjusted for the difference in static head that may exist between the part considered and the top of the boiler or pressure vessel. MAWP is not to exceed the design pressure.

1.3.3 Design Temperature

The maximum temperature used in design is not to be less than the mean metal temperature (through the thickness) expected under operating conditions. The minimum metal temperature used in design is to be the lowest expected in service, except when lower temperatures are permitted by the Rules of the recognized code or standard.

1.5 Recognized Codes or Standards

All boilers and pressure vessels required to be certified by 4-4-1/1.1 are to be designed, constructed and tested in accordance with Appendix 4-4-1A1 of this Section. Alternatively, they may comply with a recognized code or standard. The following are some of the national standards that are considered recognized for the purpose of this section:

Boilers:

- ASME Boiler and Pressure Vessel Code Section I
- British Standard BS 1113 Design and manufacture of water tube steam generating plant (including superheaters, reheaters and steel tube economizers)
- British Standard BS 2790 Specifications for the design and manufacture of shell boilers of welded construction

Pressure vessels and heat exchangers:

- ASME Boiler and Pressure Vessel Code Section VIII Div. 1; or Section VIII Div. 2
- Standards of Tubular Exchanger Manufacturers Association
- British Standard BS 5500 Specification for unfired fusion welded pressure vessels
- Japanese Industrial Standard JIS B8265 *et al* for Pressure vessels

Other national standards or codes will be considered, provided that they are no less effective.

1.7 Grouping of Boilers and Pressure Vessels

For purpose of specifying the degree of inspection and testing during the certification process, boilers and pressure vessels are categorized as in 4-4-1/Table 2.

1.9 Certification

All boilers and pressure vessels within the scope of 4-4-1/1.1 are to be certified by ABS. Mass-produced pressure vessels, including seamless extruded cylinders and fluid power cylinders, may be certified by alternative means as described in 4-4-1/1.11. 4-4-1/Table 3 provides important elements of the certification process for each group of boilers and pressure vessels. Columns 1, 2 and 3 in the table are to be complied with for all boilers and pressure vessels regardless of the chosen standard or code of compliance. Fabrication and inspection details in column 4 (see Section 2-4-3) are to be complied with also, except that considerations will be given to alternative provisions in the chosen standard or code of compliance.

TABLE 2
Grouping of Boilers and Pressure Vessels

Grp	Type	Pressure				Temperature			Volume			Thickness		ABS Type Appr Tier	Rule Reference
		bar	kgf/cm ²	psi		°C	°F		m ³	ft ³		mm	in.		
I	a) Boilers and steam generators	>3.5	>3.6	>50	–	all	all	–	all	all	–	all	all	5	4-4-1/7
	b) Pressure vessels and heat exchangers, other than d) and e) ⁽⁶⁾	>41.4	>42.2	>600	or	>371 ⁽¹⁾ >204 ⁽²⁾	>700 ⁽¹⁾ >400 ⁽²⁾	and	all	all	or	>38	>1.5	5	4-4-1/7
	c) Fired heaters for oil	>41.4	>42.2	>600	–	all	all	–	all	all	–	all	all	5	4-4-1/7
	d) Liquefied gas pressure vessel cargo tanks ⁽⁶⁾	≥2.1	≥2.1	≥30	–	all	all	–	all	all	–	all	all	5	4-4-1/7, 5C-8-4
	e) Pressure vessels and heat exchangers for toxic or corrosive substances ⁽⁶⁾	>1.0	>1.0	>15	–	all	all	–	all	all	–	all	all	5	4-4-1/7
II	a) Fired heater for oil	≤41.4 and >1.0	≤42.2 and >1.0	≤600 and >15	–	all	all	–	all	all	–	all	all	4	4-4-1/1.11
	b) Pressure vessels and heat exchangers, other than Group I b) ⁽⁶⁾	≤41.4 and >6.9	≤42.2 and >7	≤600 and >100	and	≤371 ⁽¹⁾ ≤204 ⁽²⁾	≤700 ⁽¹⁾ ≤400 ⁽²⁾	and	all	all	and	≤38	≤1.5	4	4-4-1/1.11
	c) Pressure vessels and heat exchangers, other than Group II b) ⁽⁶⁾	≤6.9 and >1.0	≤7 and >1.0	≤100 and >15	and	>149 ⁽³⁾ >66 ⁽⁴⁾ >90 ⁽⁵⁾	>300 ⁽³⁾ >150 ⁽⁴⁾ >200 ⁽⁵⁾	and	>0.14	>5	and	≤38	≤1.5	4	4-4-1/1.11

TABLE 2 (continued)
Grouping of Boilers and Pressure Vessels

Notes:

- 1 Steam, gas or vapor, other than toxic or corrosive substances.
- 2 Liquids, other than toxic and corrosive substances.
- 3 Steam, gas or vapor, and liquids excluding fuel oil, lubricating oil and thermal oil; other than toxic or corrosive substances.
- 4 Fuel oil.
- 5 Lubricating oil and thermal oil.
- 6 Internal diameter \geq 150 mm (6 in.). Vessels with smaller diameter are outside the scope of this section.

TABLE 3
Certification Details

	1	2	3	4				ABS Type Approval Tier	Rule Reference
	<i>Design approval</i>	<i>Survey during fabrication</i>	<i>Material test witnessed by Surveyor</i>	<i>Full radiography</i>	<i>Post-weld heat treatment</i>	<i>Production test plate</i>	<i>Charpy V-notch test</i>		
Group I	x	x	x	x	x	x	as required	5	4-4-1/7
Group II	x	x	-	-	-	-	as required	4	4-4-1/1.11

1.11 Special Cases

1.11.1 Independent Cargo Pressure Vessels

Pressure vessels independent of the vessel's hull and intended for the carriage of liquefied gases as cargo are, in addition to the provisions of this section, to comply with Section 5C-8-4.

Pressure vessels intended for carriage of other cargoes, such as bulk cement, which require compressed air for loading and discharging, are subject to the provisions of this section if the operating pressure and volume of the vessels exceed that indicated in 4-4-1/Table 1 item c.

1.11.2 Mass-produced Boilers and Pressure Vessels

Mass-produced boilers, pressure vessels and heat exchangers may be certified on the basis of the ABS Type Approval Program (see 1-1-4/7.7, 4-1-1/Table 5 and 1-1-A3/5), subject to their designs being approved by ABS in each case.

1.11.3 Pressure Vessels Included in Self-contained Equipment

Pressure vessels and heat exchangers, which form part of an independently manufactured and assembled unit (for example, a self-contained air conditioning or ship's stores refrigeration unit, etc.), are not subject to the requirements of this Section, provided the independently assembled unit does not form part of a ship's piping system covered under Part 4, Chapters 6, 7 and 9 and Part 6, Chapter 2.

1.11.4 Seamless Pressure Vessels for Gases

Mass-produced pressurized cylinders for storage of industrial gases such as carbon dioxide, oxygen, acetylene, etc., which are of extruded seamless construction, are to be designed, manufactured and tested in accordance with a recognized standard for this type of pressure vessel. Their acceptance will be based on their compliance with the standard as verified by either ABS or an agency recognized by a national authority (in the country of manufacture) having jurisdiction over the safety of such pressure vessels. The certificate of compliance, traceable to the cylinder's serial number, is to be presented to the Surveyor for verification in each case.

1.11.5 Fluid Power Cylinders

Hydraulic cylinders for steering gears, regardless of diameter, are to meet 4-3-4/7 and 4-3-4/19. For other hydraulic and pneumatic cylinders, regardless of diameter, see 4-6-7/3.5.5.

1.13 Plans and Data to be Submitted

1.13.1 Boilers

General arrangement

Design data: heating surface, evaporative capacity, design and working pressure and temperature, superheater header and tube mean wall temperatures, estimated pressure drop through the superheaters, safety relief valve settings and capacities, draft requirements at design conditions, number and capacity of forced draft fans.

Materials of all pressurized parts and their welded attachments

Sectional assembly

Seating arrangements

Steam and water drums, and header details

Waterwall details

Steam and superheater tubing including the maximum expected mean wall temperature of the tube wall, and the tube support arrangements

Economizer arrangement, header details, and element details

Casing arrangement

Typical weld joint designs

Post-weld heat treatment and nondestructive examination

Boiler mountings including safety valves and relieving capacities, blow-off arrangements water-gauges and try cocks, etc.

Integral piping

Reheat section (when fitted)

Fuel oil burning arrangements including burners and registers

Forced draft system

Boiler instrumentation, monitoring and control systems

1.13.2 Pressure Vessels and Heat Exchangers

General arrangements

Design data: design pressures and temperatures, fluid name, degree of radiographic examination, corrosion allowance, heat treatment (or lack of it), hydrostatic test pressure, setting of safety relief valve

Material specifications including heat treatment and mechanical properties

Shell and head details, and shell to head joint details

Nozzles, openings, manways, etc., and their attachment details; flanges and covers, as applicable

Tubes, tube sheets, heads, shell flanges, covers, baffles, tube to tubesheet joint details, packings, as applicable

Support structures, seating, etc.

1.13.3 Thermal Oil Heaters

In addition to the arrangements and details and construction details of pressure parts as required for steam boilers and heat exchangers, as appropriate, the following are to be submitted:

Thermal oil characteristics, including flash point; thermal oil deterioration testing routines and facilities

Thermal oil plant design parameters: thermal oil circulation rate; circulating pump head/capacity; designed maximum oil film temperature

Arrangement and details of appurtenances; relief valve capacities

Schematic of thermal oil piping system

Fire extinguishing fixtures for the furnace space

Instrumentation, monitoring and control systems

1.13.4 Calculations

Calculations in accordance with a recognized standard or code.

1.13.5 Fabrication

Welding procedure specifications and procedure qualification records; post-weld heat treatment procedure; nondestructive examination plan, where applicable. Welder qualification records are to be submitted to the Surveyor.

3 Materials

3.1 Permissible Materials

3.1.1 General

Pressure parts of boilers and pressure vessels are to be constructed of materials conforming to specifications permitted by the applicable boiler or pressure vessel code. Boiler and pressure vessel material specifications provided in Section 2-3-1 may be used in connection with the provisions of Appendix 4-4-1A1. Materials for non-pressure parts are to be of a weldable grade (to be verified by welding procedure qualification, for example) if such parts are to be welded to pressure parts.

3.1.2 Materials for High Temperature Service

Materials of pressure parts subjected to service temperatures higher than room temperature are to have mechanical and metallurgical properties suitable for operating under stress at such temperatures. Material specifications concerned are to have specified mechanical properties at elevated temperatures, or alternatively, the application of the materials is to be limited by allowable stresses at elevated temperatures as specified in the applicable boiler or pressure vessel standard. The use of materials specified in Section 2-3-1 is to be in accordance with the allowable stresses specified in Appendix 4-4-1A1.

3.1.3 Materials for Low Temperature Service

Materials of pressure parts subjected to low service temperatures are to have suitable notch toughness properties. Permissible materials, the allowable operating temperatures, the tests that need be conducted and the corresponding toughness criteria are to be as specified in the applicable pressure vessel standard.

3.3 Permissible Welding Consumables

Welding consumables are to conform to recognized standards. Welding consumables tested, certified and listed by ABS in its publication *Approved Welding Consumables* for meeting a standard may be used in all cases. See Section 2-4-3.

Welding consumables not so listed but specified by the manufacturer as conforming with a standard (e.g., AWS) may be used in Group II pressure vessels. Such consumables are to have been proven in qualifying the welding procedures intended to be used in the fabrication of the boiler or pressure vessel, or are to be of a make acceptable to the Surveyor. For Group I boilers and pressure vessels, such consumables are to be further represented by production test pieces taken from representative butt welds to prove the mechanical properties of the metal.

3.5 Material Certification and Tests

Materials, including welding consumables, entered into the construction of boilers and pressure vessels are to be certified by the material manufacturers as meeting the material specifications concerned. Certified mill test reports, traceable to the material concerned, are to be presented to the Surveyor for information and verification in all cases. In addition, where so indicated in 4-4-1/Table 3, materials of the main pressure parts, namely, steam and water drums, shell and heads, headers, shell flange, tubes, tubesheets, etc. are required to have their materials tested in the presence of a Surveyor to verify their compliance with the corresponding material specifications. Welding consumables, in these instances, are to have their mechanical strength verified by the testing of production test pieces.

5 Design

All boilers, steam generators, fired heaters, pressure vessels and heat exchangers required to be certified by 4-4-1/1.1 are to be designed in accordance with Appendix 4-4-1A1. Alternatively, a recognized code or standard (see 4-4-1/1.5) may be used for this purpose. All such designs are to be submitted for approval before proceeding with the fabrication.

7 Fabrication, Testing and Certification

7.1 Material Tests

Material tests are to be in accordance with 4-4-1/3.5.

7.3 Welded Fabrication

Welding of pressure parts and of non-pressure parts to pressure parts is to be performed by means of qualified welding procedures and by qualified welders. The qualification of welding procedures is to be conducted in accordance with Section 2-4-3 or the applicable boiler or pressure vessel standard or code. Welding procedure specifications and their qualification records are to be submitted for review as indicated in 4-4-1/1.13.5. The Surveyor is to have the option of witnessing the conduct of the qualification test, and may request additional qualification tests if there are reasons to doubt the soundness of the qualified procedure. Similarly, qualification of welders is to be in accordance with the applicable code and is to be to the satisfaction of the Surveyor.

7.5 Dimensional Tolerances

Parts to be welded are to be aligned within the tolerances specified in Section 2-4-2 or the applicable standard or code. The fitting of the main seams is to be examined by the Surveyor prior to welding. The conformance of formed heads to the theoretical shape and the out-of-roundness of the finished shells are to be within specified tolerances and are to be verified to the satisfaction of the Surveyor.

7.7 Nondestructive Examination

Radiographic examinations are to be in accordance with 2-4-2/23 or the applicable standard or code. All Group I boilers and pressure vessels are to have their butt seams fully radiographed. See 4-4-1/1.9. Group II pressure vessels are to be radiographed to the extent as required by the designed joint-efficiency. The radiography standard and acceptance criteria, along with the degree of other nondestructive examination, such as ultra-sonic, dye penetrant, or magnetic particle, are to be in accordance with the chosen standard or code. Radiographic films are to be submitted to the surveyor for review.

7.9 Preheat and Postweld Heat Treatment

Preheat and postweld heat treatment are to be in accordance with 2-4-2/11 through 2-4-2/17 or the applicable standard or code. All Group I boilers and pressure vessels are to be postweld heat treated. See 4-4-1/1.9. In addition, postweld heat treatment is to be carried out where required by, and in accordance with the applicable boiler or pressure vessel code or standard. The postweld heat treatment procedure is to be submitted to the Surveyor for review prior to the heat treatment.

7.11 Hydrostatic Tests

7.11.1 Boilers

The Surveyor is to witness hydrostatic tests on all boilers. The test pressure is not to be less than 1.5 times the maximum allowable working pressure or at such pressures as specified by the standard or code of compliance.

7.11.2 Pressure Vessels

The Surveyor is to witness hydrostatic tests on all pressure vessels. The test pressure is not to be less than 1.3 times the maximum allowable working pressure or at such pressures as specified by the standard or code of compliance. Where hydrostatic tests are impracticable, alternative methods of pressure tests, such as a pneumatic pressure test, may be considered for pressure vessels, subject to such test procedures being submitted for consideration in each case.

7.13 Manufacturer's Documentation

The manufacturer is to submit documentation of fabrication records, including but not limited to material certificates, welding procedure qualification records, welder qualification records, heat treatment reports, nondestructive examination reports and dimensional check reports, as applicable, to the Surveyor for final review and acceptance.

9 Boiler Appurtenances

9.1 Safety Valves

9.1.1 General

9.1.1(a) Boiler. Each boiler (including exhaust gas boiler) and steam generator is to be fitted with at least one safety valve and where the water-heating surface is more than 46.5 m² (500 ft²), two or more safety valves are to be provided. The valves are to be of equal size as far as practicable and their aggregate relieving capacity is not to be less than the evaporating capacity of the boiler under maximum operating conditions. In no case, however, is the inlet diameter of any safety valve for propulsion boiler and superheaters used to generate steam for main propulsion and other machinery to be less than 38 mm (1.5 in.) nor more than 102 mm (4 in.). For auxiliary boilers and exhaust gas economizers, the inlet diameter of the safety valve must not be less than 19 mm (³/₄ in.) nor more than 102 mm (4 in.).

9.1.1(b) Superheater. Each superheater, regardless of whether it can be isolated from the boiler or not, is to be fitted with at least one safety valve on the superheater outlet. See also 4-4-1/9.1.2(b).

9.1.1(c) Economizers. Each economizer, where fitted with a bypass, is to be provided with a sentinel relief valve, unless the bypass arrangement will prevent a buildup of pressure in the economizer when it is bypassed.

9.1.2 Minimum Relieving Capacity

9.1.2(a) Boiler. In all cases, the safety-valve relieving capacity is to be determined on the basis of the boiler heating surface and water-wall heating surface along with the fuel-burning equipment, and is not to be less than that given in the following table. Where certification by the boiler manufacturer of the evaporative capacity of the boiler under maximum operating conditions indicates a higher capacity, the higher capacity is to be used.

<i>Minimum mass of steam per hour per heating surface area of oil-fired boilers, kg/h/m² (lb/h/ft²)</i>		
<i>Boiler Type</i>	<i>Boiler Heating Surface</i>	<i>Waterwall Surface</i>
Fire-tube	39.1 (8)	68.3 (14)
Water-tube	48.8 (10)	78.1 (16)

9.1.2(b) *Boilers with integral superheaters.* Where a superheater is fitted as an integral part of a boiler with no intervening valve between the superheater and the boiler, the relieving capacity of the superheater safety valve, based on the reduced pressure, may be included in determining the total relieving capacity of the safety valves for the boiler as a whole. In such a case, the relieving capacity of the superheater safety valve is not to be credited for more than 25% of the total capacity required. The safety valves are to be so set and proportioned that, under any relieving condition, sufficient steam will pass through the superheater to prevent overheating the superheater. Specially designed full-flow superheater valves, pilot-operated from the steam drum, may be used.

9.1.2(c) *Exhaust gas boiler.* Minimum required relieving capacity of the safety valve is to be determined by the manufacturer. If auxiliary firing is intended in combination with exhaust gas heating, the relieving capacity is to take this into consideration. If auxiliary firing is intended only as an alternative to exhaust gas heating, the relieving capacity is to be based on the higher of the two.

9.1.2(d) *Pressure rise during relieving.* For each boiler, the total capacity of the installed safety valves is to be such that the valves will discharge all steam that can be generated by the boiler without allowing the pressure to rise more than 6% above the maximum allowable working pressure. See 4-4-1/9.1.8.

9.1.3 Pressure Settings

9.1.3(a) *Boiler drum.* At least one safety valve on the boiler drum is to be set at or below the maximum allowable working pressure. If more than one safety valve is installed, the highest setting among the safety valves is not to exceed the maximum allowable working pressure by more than 3%. The range of pressure settings of all the drum safety valves is not to exceed 10% of the highest pressure to which any safety valve is set.

In no case is the relief pressure to be greater than the design pressure of the steam piping or that of the machinery connected to the boiler plus the pressure drop in the steam piping.

9.1.3(b) *Superheater.* Where a superheater is fitted, the superheater safety valve is to be set to relieve at a pressure no greater than the design pressure of the steam piping or the design pressure of the machinery connected to the superheater plus pressure drop in the steam piping. In no case is the superheater safety valve to be set at a pressure greater than the design pressure of the superheater.

In connection with the superheater, the safety valves on the boiler drum are to be set at a pressure not less than the superheater-valve setting plus 0.34 bar (0.35 kgf/cm², 5 psi), plus approximately the normal-load pressure drop through the superheater. See also 4-4-1/9.1.3(a).

9.1.4 Easing Gear

Each boiler and superheater safety valve is to be fitted with an efficient mechanical means by which the valve disc may be positively lifted from its seat. This mechanism is to be so arranged that the valves may be safely operated from the boiler room or machinery space platforms, either by hand or by any approved power arrangement.

9.1.5 Connection to Boiler

Safety valves are to be connected directly to the boiler, except that they may be mounted on a common fitting; see 4-4-1/9.3. However, they are not to be mounted on the same fitting as that for the main or auxiliary steam outlet. This does not apply to superheater safety valves, which may be mounted on the fitting for the superheater steam outlet.

9.1.6 Escape Pipe

The area of the escape pipe is to be at least equal to the combined outlet area of all of the safety valves discharging into it. The pipe is to be so routed as to prevent the accumulation of condensate and is to be so supported that the body of the safety valve is not subjected to undue load or moment.

9.1.7 Drain Pipe

Safety valve chests are to be fitted with drain pipes leading to the bilges or a suitable tank. No valve or cock is to be fitted in the drain pipe.

9.1.8 Pressure Accumulation Test

Safety valves are to be set under steam and tested with pressure accumulation tests in the presence of the Surveyor. The boiler pressure is not to rise more than 6% above the maximum allowable working pressure when the steam stop valve is closed under full firing condition for a duration of 15 minutes for firetube boilers and 7 minutes for watertube boilers. During this test, no more feed water is to be supplied than that necessary to maintain a safe working water level. The popping point of each safety valve is not to be more than 3% above its set pressure.

Where such accumulation tests are impractical because of superheater design, an application to omit such tests may be approved, provided the following are complied with:

- All safety valves are to be set in the presence of the Surveyor.
- Capacity tests have been completed in the presence of the Surveyor on each valve type.
- The valve manufacturer supplies a certificate for each safety valve stating its capacity at the maximum allowable working pressure and temperature of the boiler.
- The boiler manufacturer supplies a certificate stating the maximum evaporation of the boiler.
- Due consideration is given to back pressure in the safety valve steam escape pipe.

9.1.9 Changes in Safety Valve Setting

Where, for any reason, the maximum allowable working pressure is lower than that for which the boiler and safety valves were originally designed, the relieving capacity of the valves under lower pressure is to be checked against the evaporating capacity of the boiler. For this purpose, a guarantee from the manufacturer that the valve capacity is sufficient for the new conditions is to be submitted for approval, or it is to be demonstrated by a pressure accumulation test, as specified in 4-4-1/9.1.8, conducted in the presence of a Surveyor.

9.3 Permissible Valve Connections on Boilers

9.3.1 Connection Method

All valves of more than 30 mm (1.25 in.) nominal diameter are to be connected to the boiler with welded or flanged joints. Where the thickness of the shell plate is over 12.7 mm (0.5 in.), or where the plate has been reinforced by welded pads, valves 30 mm (1.25 in.) nominal diameter and under may be attached by short, extra-heavy screwed nipples.

For studded connections, stud holes are not to penetrate the whole thickness of the shell plate and the depth of the thread is to be at least equal to 1.5 times the diameter of the stud.

9.3.2 Valve Materials

All valves attached to a boiler, either directly or by means of a distance piece, are to be forged or cast steel, except where the pressure does not exceed 24.1 bar (24.6 kgf/cm², 350 psi) and the steam temperature does not exceed 232°C (450°F), nodular cast iron is to be in accordance with 2-3-10/1.

Where temperature does not exceed 208°C (406°F), valves may be made of Type 1 bronze complying with 2-3-14/1. Where high temperature bronze is used, the temperature limit may be 288°C (550°F).

9.3.3 Valve Design

Valves are to comply with a recognized national standard, and are to be permanently marked in accordance with the requirements of the standard. Valves not complying with a recognized national standard are to be approved in each case. See 4-6-2/5.15.

9.5 Steam and Feed Valves

9.5.1 General

All steam and feedwater connections to boilers are to have stop valves connected directly to the boilers. A distance piece between the boiler and the valve is permissible if the piece is as short as possible. The stop valves are to be arranged to close against boiler pressure, except that the stop valves on feedwater connections may close against feed water pressure. Screw down valves are to close with a clockwise motion of the hand when facing the top of the stem.

9.5.2 Steam Stop Valves

One steam stop valve is to be fitted to each steam outlet from a propulsion or auxiliary boiler. Where a superheater is fitted, the steam stop valve is to be located at the superheater to insure a flow of steam through the superheater at all times, except that where the total superheat temperature is low, alternative arrangement may be considered. Each steam stop valve exceeding 150 mm (6 in.) nominal diameter is to be fitted with a by-pass valve for plant warm-up purposes.

Where two or more boilers are connected, the steam stop valve is to be of the non-return type. In addition, the steam outlet connecting pipe from each boiler is to be provided with an additional shut off valve located in series and downstream of the required steam stop valve.

9.5.3 Feed Valves

9.5.3(a) Temperature differential. For boilers with a design pressure of 27.6 bar (28 kgf/cm², 400 psi) or over, the feed-water connection to the drum is to be fitted with a sleeve or other suitable device to reduce the effects of metal temperature differentials between the feed pipe and the shell or head of the drum.

Feed water is not to be discharged into a boiler in such a manner that it impinges directly against surfaces exposed to hot gases or the radiant heat of the fire.

9.5.3(b) Feed stop valve. A feed stop valve is to be fitted to each feedwater line to the boiler and is to be attached directly to the boiler. If an economizer forms a part of the boiler, the feedwater stop valve may be attached directly on the economizer. Consideration will be given to locating the valve near an operating platform, provided that the pipe between the economizer and the valve is a seamless steel pipe having all joints welded.

For feed water system requirements, see 4-6-6/5.

9.5.3(c) Feed stop check valve. In addition and adjacent to the stop valve in 4-4-1/9.5.3(b), a stop check valve is to be fitted, or as close thereto as practicable. A feedwater regulator may be interposed between the stop valve and the stop check valve if a by-pass is also fitted.

9.5.3(d) Feed water line between economizer and boiler. Boilers fitted with economizers are to be provided with a check valve located in the feed water line between the economizer and the boiler drum. This check valve is to be located as close to the boiler drum feed water inlet nozzle as possible. When a by-pass is provided for the economizer, the check valve is to be of the stop-check type.

9.7 Instrument Connections for Boilers

9.7.1 Water Gauges

9.7.1(a) Number of gauges. Each boiler is to have at least two approved independent means of indicating the water level, one of which is to be a direct reading gauge glass. On double-ended fire-tube boilers and on boilers with drums more than 4 m in length and with drum axis athwartships, these water-level indicators are to be fitted on or near both ends.

9.7.1(b) Gauge details. Water gauges are to be fitted with shutoff valves, top and bottom, and drain valves. Shutoff valves are to be of through-flow construction and are to have a means for clearly indicating whether they are open or closed. Shutoff valves for water columns are to be attached directly to the boilers, and the pipes to the columns are not to lead through smoke boxes or uptakes unless they are completely enclosed in open-ended tubes of sufficient size to permit free air circulation around the pipes. Glass water gauges are to be so located that the lowest visible level in the glass is either not lower than 51 mm (2 in.) above the lowest permissible water level specified in 4-4-1/9.7.1(c) below.

9.7.1(c) *Lowest permissible water level.* The lowest permissible water level referred to in 4-4-1/9.7.1(b) is to be as follows.

- Water tube boilers: the lowest permissible water level is to be just above [usually 25 mm (1 in.) above] the top row of tubes when cold; for boilers with tubes not submerged when cold, the manufacturer is to submit a lowest permissible level for consideration. In all cases, the lowest permissible level is to be submitted with the boiler design in each case for approval.
- Internally fired fire-tube boilers with combustion chambers integral with the boiler: 51 mm (2 in.) above the highest part of the combustion chamber.
- Vertical submerged-tube boilers: 25 mm (1 in.) above the upper tube sheet.
- Vertical fire-tube boilers: one half the length of the tubes above the lower tube sheet.

9.7.1(d) *Marking of furnace top.* The level of the highest part of the effective heating surface, e.g., the furnace crown of a vertical boiler and the combustion chamber top of a horizontal boiler, is to be clearly marked in a position adjacent to the water gauge glass.

9.7.2 Pressure Gauges

Each boiler is to be provided with a steam pressure gauge, which is to indicate pressure correctly up to at least 1.5 times the pressure at which the safety valves are set. Double-ended boilers are to have one such gauge at each end. Gauges are to be located where they can be easily seen and the highest permissible working pressure is to be specially marked.

9.9 Miscellaneous Connections

9.9.1 Try Cocks

Try cocks, when fitted, are to be attached directly to the head or shell of a boiler, except that in the case of water-tube boilers, they may be attached to the water column. The lowest try cock is to be located 51 mm (2 in.) higher than the lowest visible part of the gauge glass. Try cocks may only be considered one of the required means for determining the water level where the boiler is an auxiliary installation with a maximum allowable working pressure of not more than 10.3 bar (10.5 kgf/cm², 150 psi) and where the steam is not used for main propulsion.

9.9.2 Test Connections

At least one valve is to be fitted to each boiler for boiler-water testing. They are to be directly connected to the boiler in a convenient location, but are not to be connected to the water column or gauge.

9.9.3 Blow-off Arrangements

Each boiler is to have at least one blow-off valve attached to the boiler drum, either at the lowest part of the boiler or fitted with an internal pipe leading to the lowest part. Where this is not practicable for water tube boilers, the valve may be suitably located outside the boiler casing and attached to a pipe led to the lowest part of the boiler. This pipe is to be well supported, and where it may be exposed to direct heat from fire, it is to be protected by refractory or other heat resisting material so arranged that the pipe may be inspected and is not constrained against expansion.

Where a surface blow is fitted, the valve is to be located within the permissible range of the water level or fitted with a scum pan or pipe at this level.

9.9.4 Superheater Drain and Vent

Superheaters are to have valves or cocks fitted to permit drainage of headers. Arrangements are to be made for venting the superheater, and to permit steam circulation through the superheater when starting the boiler.

9.11 Inspection Openings

All boilers are to be provided with sufficient manholes or handholes for inspection and cleaning. The clear opening of manholes is to be not less than 300 mm by 400 mm (12 in. by 16 in.). A handhole opening in a boiler shell is not to be less than 60 mm by 90 mm (2.25 in. by 3.5 in.). Where, due to size or interior arrangement of a boiler, it is impractical to provide a manhole or other suitable opening for direct access, there are to be two or more handholes or other suitable openings through which the interior can be inspected. Consideration will be given to alternative provisions in other boiler standards or codes.

9.13 Dampers

When dampers are installed in the funnels or uptakes of vessels using oil, they are not to obstruct more than two-thirds of the flue area when closed, and they are to be capable of being locked in the open position when the boilers are in operation. In any damper installation, the position of the damper and the degree of its opening is to be clearly indicated. Where fitted, power-operated dampers for the regulation of superheater steam temperatures are to be submitted for approval in each case.

9.15 Guidance for Spare Parts

While spare parts are not required for class, the spare parts listed below are for unrestricted service and are provided as a guidance to assist in ordering spare parts which may be appropriate for the intended service. The maintenance of spare parts aboard each vessel is the responsibility of the owner.

- 1 set of springs and one set of studs and nuts for one safety valve of each size
- 12 gauge glasses with packings per boiler if of the round gauge glass type
- 2 gauge glasses with packings per boiler and 1 frame for each of 2 boilers if of the flat-gauge-glass type
- 1 boiler pressure gauge or gauge-testing apparatus
- 24 tube stoppers, but need not be more than the number necessary to plug 5% of each size of generator, waterwall, economizer and superheater tube for one boiler
- Tube material, welding machine, special welding rods and other materials needed to make weld repairs on welded wall boiler tubes. This equipment would replace tube stoppers needed for water walls
- Necessary special tools

9.17 Additional Requirements for Shell Type Exhaust Gas Economizers

9.17.1 Application

This requirement is applicable to shell type exhaust gas economizers that are intended to be operated in a flooded condition and that can be isolated from the steam piping system.

9.17.2 Design and Construction

Design and construction of shell type exhaust gas economizers are to pay particular attention to the welding, heat treatment and inspection arrangements at the tube plate connection to the shell.

9.17.3 Pressure Relief

9.17.3(a) Number of Valves. The shell type exhaust gas economizer is to be provided with at least one safety valve, and when it has a total heating surface of 46.5 m² (500 ft²) or more, it is to be provided with at least two safety valves in accordance with 4-4-1/9.1.1

9.17.3(b) Discharge Pipe. To avoid the accumulation of condensate on the outlet side of safety valves, the discharge pipes and/or safety valve housings are to be fitted with drainage arrangements from the lowest part, directed with continuous fall to a position clear of the shell type exhaust gas economizers where it will not pose threats to either personnel or machinery. No valves or cocks are to be fitted in the drainage arrangements.

9.17.4 Pressure Indication

Every shell type exhaust gas economizer is to be provided with a means of indicating the internal pressure. A means of indicating the internal pressure is to be located so that the pressure can be easily read from any position from which the pressure may be controlled.

9.17.5 Lagging

Every shell type exhaust gas economizer is to be provided with removable lagging at the circumference of the tube end plates to enable ultrasonic examination of the tube plate to shell connection.

9.17.6 Feed Water

Every shell type exhaust gas economizer is to be provided with arrangements for pre-heating and de-aeration, addition of water treatment or combination thereof to control the quality of feed water to within the manufacturer's recommendations.

9.17.7 Operating Instructions

The manufacturer is to provide operating instructions for each shell type exhaust gas economizer which is to include reference to:

- i) Feed water treatment and sampling arrangements.
- ii) Operating temperatures – exhaust gas and feed water temperatures.
- iii) Operating pressure.
- iv) Inspection and cleaning procedures.
- v) Records of maintenance and inspection.
- vi) The need to maintain adequate water flow through the economizer under all operating conditions.
- vii) Periodical operational checks of the safety devices to be carried out by the operating personnel and to be documented accordingly.
- viii) Procedures for using the exhaust gas economizer in the dry condition.
- ix) Procedures for maintenance and overhaul of safety valves.

11 Boiler Control

11.1 Local Control and Monitoring

Suitable means to effectively operate, control and monitor the operation of oil fired boilers and their associated auxiliaries are to be provided locally. Their operational status is to be indicated by conventional instruments, gauges, lights or other devices to show the functional condition of the fuel system, feed water and steam systems. For details of these piping systems, see Section 4-6-6.

11.3 Manual Emergency Shutdown

Boiler forced-draft or induced-draft fans and fuel oil service pumps are to be fitted with remote means of control situated outside the space in which they are located so that they may be stopped in the event of fire arising in that space.

11.5 Control of Fired Boilers

11.5.1 Automatic Shutdown

All boilers, regardless of duties and degree of automation, are to be fitted with the following automatic shutdowns:

11.5.1(a) Burner Flame Scanner. Each burner is to be fitted with a flame scanner designed to automatically shut off the fuel supply to the burner in the event of flame failure. The shutoff is to be achieved within 6 seconds following flame extinguishment. In the case of failure of the flame scanner, the fuel to the burner is to be shut off automatically.

11.5.1(b) High and low water level sensors. High and low water level sensors are to be provided. A low water condition is to automatically shut off the fuel supply to the burners. The low water sensor is to be set to operate when the water level falls to a minimum safe level but at a level no lower than that visible in the gauge glass. Additionally, the water level sensor is to be located to minimize the effects of roll and pitch, or is to be provided with a short-time delay (approximately 5 seconds) to prevent trip-out due to transients or to the vessel's motion.

For auxiliary boilers intended for non-automatic operation under local supervision, a high water level sensor need not be fitted.

11.5.1(c) *Forced draft.* Forced draft failure is to automatically shut off the fuel supply to the burners.

11.5.1(d) *Boiler control power.* Loss of boiler control power is to automatically shut off the fuel supply to the burners.

11.5.1(e) *Burners.* Burners are to be arranged so that they cannot be withdrawn unless the fuel supply to the burners is cut off.

11.5.2 Alarms

11.5.2(a) *Fuel oil shutoff.* Actuation of any of the fuel shutoffs specified in 4-4-1/11.5.1 is to alert the boiler operator at the appropriate control station of such condition by means of visual and audible alarms.

11.5.2(b) *Air supply and flue.* Means are to be fitted to detect and alarm at an early stage a fire in the boiler air supply and the exhaust duct. In the absence of an air casing for small boilers, heat (temperature) detector fitted in the windbox would meet this requirement. Further, for auxiliary boilers, without an air casing, the required means to detect and alarm of a fire in the boiler air supply duct may be omitted provided the burner system is a pressure jet type and the windbox forms part of the combustion fan housing.

4-4-1/Table 4 provides a summary of the required alarms and shutdowns.

TABLE 4
List of Alarms and Shutdowns – Fired Boilers

<i>Monitored Parameter</i>		<i>Alarm</i>	<i>Automatic Shutdown with Alarm</i>	<i>Notes</i>
A1	Boiler drum water level – low	x		4-4-1/11.5.1(b)
A2	Boiler drum water level – low-low		x	4-4-1/11.5.1(b)
A3	Boiler drum water level – high	x		4-4-1/11.5.1(b)
B1	Forced draft fan – failure		x	4-4-1/11.5.1(c)
B2	Air Supply Casing – fire	x		4-4-1/11.5.2(b)
C1	Burner flame – failure		x	4-4-1/11.5.1(a)
C2	Flame scanner – failure		x	4-4-1/11.5.1(a)
D1	Atomizing medium – off-limit condition	x		4-4-1/11.5.3(e)
E1	Uptake gas temperature – high	x		4-4-1/11.5.2(b)
F1	Control power supply – loss		x	4-4-1/11.5.1(d)

11.5.3 Automatic Boiler Control

Regardless of duties, boilers fitted with automatic control are to comply with 4-4-1/11.5.1 and 4-4-1/11.5.2 and the following.

11.5.3(a) *Automatic boiler purge.* Where boilers are fitted with an automatic ignition system, a timed boiler purge with all air registers open is required prior to ignition of the initial burner. The boiler purge may be initiated manually or automatically. The purge time is to be based on a minimum of four air changes of the combustion chamber and furnace passes. It is to be proven that the forced draft fan is operating and the air registers and dampers are open before the purge time commences.

11.5.3(b) *Trial-for-ignition period.* Means provided to temporarily by-pass the flame-scanner control system during a trial-for-ignition period is to be limited to 15 seconds from the time the fuel reaches the burners. Except for this trial-for-ignition period, there is to be no means provided to by-pass one or more of the burner flame scanner systems unless the boiler is being locally controlled.

11.5.3(c) *Automatic burner light-off.* Where boilers are fitted with an automatic ignition system, and where residual fuel oil is used, means are to be provided for lighting off the burners with igniters lighting properly-heated residual fuel oil. Alternatively, the burners may be lighted off with a light oil used as a pilot to ignite residual fuel oil. If all burners experience a flame failure, the initial burner is to be brought back into automatic service only in the low-firing position. To avoid the possibility of a false indication due to the failure of the flame scanner in the “flame-on” mode, the initial light-off burner is to be fitted with dual scanners or a scanner of the self-checking type.

11.5.3(d) *Post purge.* Immediately after normal shutdown of the boiler, an automatic purge of the boiler equal to the volume and duration of the pre-purge is to occur. Following closing of the master fuel valve due to safety actions, the post purge is not to automatically occur; it is to be carried out under manual control.

11.5.3(e) *Atomizing medium.* Off-limit condition of burner primary-air pressure or atomizing-steam pressure is to be alarmed.

11.7 Control for Waste Heat Boilers

In general, control of waste heat boilers is to be as for fired boilers, as applicable. The following specific requirements are also applicable.

11.7.1 Smoke Tube Type

A low water level condition is to be alarmed. Arrangements are to be provided to divert the exhaust gas in a low water level condition, either manually or automatically. Automatic diversion of exhaust gas is also to be alarmed.

Note: The above requirements for by-pass/diversion arrangements and alarming are not applicable to waste heat boilers designed for dry condition operations.

11.7.2 Water Tube Type

A condition of low water flow in the tubes is to be alarmed. Arrangements are to be provided to automatically start a standby feed water pump. 4-4-1/Table 5 provides a summary of the required alarms.

TABLE 5
List of Alarms – Waste Heat Boilers

<i>Monitored Parameter</i>		<i>Alarm</i>	<i>Notes</i>
<i>Smoke tube type</i>			
A1	Boiler drum water level – low	x	4-4-1/11.7.1
B1	Exhaust gas automatic diversion	x	4-4-1/11.7.1
C1	Exhaust gas temperature at outlet – high	x	4-4-1/11.5.1
<i>Water tube type</i>			
D1	Water flow in the tubes – low	x	4-4-1/11.7.2
E1	Exhaust gas temperature at outlet – high	x	4-4-1/11.5.2

11.7.3 Soot Cleaning

Waste heat boilers with extended surface tubes are to be provided with soot cleaning arrangements, which are to be available while the boiler is in operation.

11.9 Control for Fired Water Heaters

In general, control of fired water heaters is to be as for fired boilers, as applicable.

4-4-1/Table 6 provides a summary of the required alarms and shutdowns.

TABLE 6
List of Alarms and Shutdowns – Fired Water Heaters

<i>Monitored Parameter</i>		<i>Alarm</i>	<i>Automatic Shutdown with Alarm</i>	<i>Notes</i>
A1	Heater water level – low	x		4-4-1/11.5.1(b)
A2	Heater water level – low-low		x	4-4-1/11.9 [4-4-1/11.5.1(b)]
A3	Heater water level – high	x		4-4-1/11.5.1(b)
B1	Forced draft fan – failure		x	4-4-1/11.9 [4-4-1/11.5.1(c)]
B2	Air supply casing – fire	x		4-4-1/11.5.2(b)
C1	Burner flame – failure		x	4-4-1/11.9 [4-4-1/11.5.1(a)]
C2	Flame scanner – failure		x	4-4-1/11.9 [4-4-1/11.5.1(a)]
D1	Atomizing medium – off limit condition	x		4-4-1/11.9 [4-4-1/11.5.3(e)]
E1	Uptake gas temperature – high	x		4-4-1/11.5.2(b)
F1	Control power supply – loss			4-4-1/11.9 [4-4-1/11.5.1(d)]

13 Thermal Oil Heaters

13.1 Appurtenances

13.1.1 Relief Valve

Each fired or exhaust gas heater for thermal oil is to be fitted with a suitable liquid relief valve. The relief valve is to be arranged to discharge into a suitable collection tank.

13.1.2 Sampling

Means are to be fitted to allow samples of thermal oil to be taken periodically for testing. Facilities are to be provided onboard for carrying out the necessary tests.

13.1.3 Expansion Tank

Vents from the thermal oil expansion tank and thermal oil storage tank are to be led to the weather. The pipe connection between the heater and the expansion tank is to be fitted with a valve at the tank capable of local manual operation and remote shutdown from outside the space where the tank is located.

13.3 Thermal Oil Heater Control

13.3.1 Local Control and Monitoring

Suitable means to effectively operate, control and monitor the operation of oil fired thermal oil heaters and their associated auxiliaries are to be provided locally. Their operational status is to be indicated by conventional instruments, gauges, lights or other devices to show the functional condition of fuel system, thermal oil circulation system, forced-draft system and flue gas system.

13.3.2 Automatic Control

In general, the thermal oil heating system is to be operated with an automatic burner and flow regulation control capable of maintaining the thermal oil at the desired temperature for the full range of operating conditions.

13.3.3 Monitoring and Automatic Shutdown

The requirements of 4-4-1/11.5.1(a), 4-4-1/11.5.1(c), 4-4-1/11.5.1(d) and 4-4-1/11.5.1(e) for boilers are also applicable for thermal oil heaters. In addition, automatic fuel shutoff is to be fitted for the conditions as indicated in 4-4-1/Table 7:

TABLE 7
List of Alarms and Shutdowns – Fired Thermal Oil Heaters

<i>Monitored Parameter</i>		<i>Automatic Shutdown with Alarm</i>	<i>Notes</i>
A1	Burner flame – failure	x	4-4-1/13.3.3 [4-4-1/11.5.1(a)]
A2	Flame scanner – failure	x	4-4-1/13.3.3 [4-4-1/11.5.1(a)]
B1	Forced draft system – failure	x	[4-4-1/11.5.1(c)]
C1	Control power supply – loss	x	[4-4-1/11.5.1(d)]
D1	Thermal oil expansion tank level – low	x	4-4-1/13.3.3
D2	Thermal oil temperature at oil outlet – high	x	4-4-1/13.3.3
D3	Thermal oil pressure or flow in circulation system – low	x	4-4-1/13.3.3
E1	Flue gas temperature – high	x	4-4-1/13.3.3

13.3.4 Remote Shutdown

Thermal oil circulating pumps, fuel oil service pumps and forced-draft fans are to be fitted with local means of operation and remote means of stopping from outside the space in which these equipment are located.

13.3.5 Valve Operation

The thermal oil main inlet and outlet are to be provided with stop valves arranged for local manual operation and for remote shutdown from outside the space in which the heater is located. Alternatively, arrangements are to be provided for quick gravity discharge of the thermal oil to a collection tank.

13.3.6 Fire Extinguishing System

The furnaces of thermal oil heaters are to be fitted with a fixed fire extinguishing system capable of being actuated locally and remotely from outside the space in which the heater is located.

13.5 Exhaust-gas Thermal Oil Heaters

Exhaust-gas thermal oil heaters are to comply with the following additional requirements:

- i) The heater is to be so designed and installed that the tubes may be easily and readily examined for signs of corrosion and leakage.
- ii) A high temperature alarm is to be provided in the exhaust gas piping for fire detection purposes.
- iii) A fixed fire extinguishing and cooling system is to be installed within the exhaust gas piping. This may be a water drenching system, provided arrangements are made below the heater to collect and drain the water.

4-4-1/Table 8 provides a summary of the required alarms and shutdown.

TABLE 8
List of Alarms and Shutdowns – Exhaust-gas Thermal Oil Heaters

<i>Monitored Parameter</i>		<i>Alarm</i>	<i>Automatic Shutdown with Alarm</i>	<i>Notes</i>
A1	Thermal oil expansion tank level – low		x	4-4-1/13.5 (4-4-1/13.3.3)
A2	Thermal oil temperature at oil outlet – high		x	4-4-1/13.5 (4-4-1/13.3.3)
A3	Thermal oil pressure or flow in circulation system – low		x	4-4-1/13.5 (4-4-1/13.3.3)
B1	Exhaust gas temperature – high	x		4-4-1/13.5 ii)

15 Incinerators

15.1 Local Control and Monitoring

Suitable means to effectively operate, control and monitor the operation of incinerators and their associated auxiliaries are to be provided locally. Their operational status is to be indicated by conventional instruments, gauges, lights or other devices to show the functional condition of the fuel system, furnace temperature, forced-draft system and flue gas system. The provisions of 4-6-6/7 pertaining to the boiler fuel oil service piping system are also applicable to the incinerator fuel oil system.

15.3 Emergency Shutdown

Fuel oil service pumps and forced-draft fans are to be fitted with local means of operation and remote means of stopping from outside the space in which they are located.

15.5 Automatic Shutdowns

The requirements of 4-4-1/11.5.1(a), 4-4-1/11.5.1(c), 4-4-1/11.5.1(d) and 4-4-1/11.5.1(e) for boilers are also applicable for incinerator. In addition, automatic fuel shutoff is to be fitted for the following conditions:

- Flue gas temperature high
- Furnace temperature high

17 Pressure Vessel and Heat Exchanger Appurtenances

17.1 Pressure Relief Valve

Every pressure vessel and each chamber of every heat exchanger which can be subjected to a pressure greater than its design pressure is to be fitted with a pressure relief valve of suitable capacity. The relief valve is to be set at not more than the maximum allowable working pressure and is to be sized to prevent the pressure in the vessel from rising more than 10% or 0.21 bar (0.21 kgf/cm², 3 psi), whichever is greater, above the maximum allowable working pressure. Consideration will be given to the installation of the pressure relief valve in the piping system connected to the pressure vessel, provided that this relief valve is of the required capacity and that it cannot be isolated from the pressure vessel by the intervening valve. Attention is also to be directed to the requirements of the safety relief valve in the code or standard of compliance.

17.3 Inspection Openings

17.3.1 Diameter Over 915 mm (36 in.)

All pressure vessels and heat exchangers over 915 mm (36 in.) inside diameter are to be provided with a manhole or at least two handholes. An elliptical or obround manhole is not to be less than 279 mm by 381 mm (11 in. by 15 in.) or 254 mm by 406 mm (10 in. by 16 in.). A circular manhole is not to be less than 381 mm (15 in.) inside diameter and a handhole is not to be less than 102 mm by 152 mm (4 in. by 6 in.).

17.3.2 Diameter Over 457 mm (18 in.)

At least two inspection openings, closed by pipe plugs of not less than 50 mm (2 in.) nominal, will be acceptable for vessels with inside diameters of 915 mm (36 in.) or less and over 457 mm (18 in.).

17.3.3 Diameter Over 305 mm (12 in.)

For vessel inside diameters 457 mm (18 in.) or less and over 305 mm (12 in.), at least two pipe plugs of not less than 40 mm (1.5 in.) nominal may be used.

17.3.4 Diameter 305 mm (12 in.) or Less

For vessel inside diameters 305 mm (12 in.) or less, at least two pipe plugs of not less than 20 mm ($\frac{3}{4}$ in.) nominal may be used.

17.3.5 Alternative Arrangements

Consideration will be given to alternative arrangements which can be shown to provide for an equivalent degree of internal inspection. Flanged and/or threaded connections from which piping instruments or similar attachments can be removed may be an acceptable alternative, provided that the connections are at least equal to the size of the required openings and the connections are sized and located to afford at least an equal view of the interior as the required openings.

17.5 Drain

Pressure vessels subject to corrosion are to be fitted with a suitable drain opening at the lowest point practicable; or a pipe may be used extending inward from any location to the lowest point.

19 Installation and Shipboard Trials

19.1 Seating Arrangements

Boilers, pressure vessels and other pressurized or fired equipment are to be properly secured in position on supports constructed in accordance with approved plans. Structural supports for fired equipment are not to be of heat sensitive material.

19.3 Boiler Installation

19.3.1 Bottom Clearance

The distance between the boiler and the floors or inner bottom is not to be less than 200 mm (8 in.) at the lowest part of a cylindrical boiler. This distance is not to be less than 750 mm (30 in.) between the bottom of the furnace (or boiler pan) and tank top (or floor) in the case of water-tube boilers. See also 3-2-4/1.1 and 3-2-4/9.5.

19.3.2 Side Clearance

The distance between boilers and vertical bulkheads is to be sufficient to provide access for maintenance of the structure; and, in the case of bulkheads in way of fuel oil and other oil tanks, the clearance is to be sufficient to prevent the temperature of the bulkhead from approaching the flash point of the oil. This clearance, generally, is to be at least 750 mm (30 in.).

19.3.3 Top Clearance

Sufficient head room is to be provided at the top of boiler to allow for adequate heat dissipation. This clearance is, generally, not to be less than 1270 mm (50 in.). No fuel oil or other oil tank is to be installed directly above any boiler.

19.3.4 Tween Deck Installation

Where boilers are located on tween decks in machinery spaces and boiler rooms are not separated from a machinery space by watertight bulkheads, the tween decks are to be provided with coamings at least 75 mm (3 in.) in height. This area may be drained to the bilges.

19.3.5 Hot Surfaces

Hot surfaces likely to come into contact with the crew during operation are to be suitably guarded or insulated. Where the temperature of hot surfaces are likely to exceed 220°C (428°F), and where any leakage, under pressure or otherwise, of fuel oil, lubricating oil or other flammable liquid is likely to come into contact with such surfaces, they are to be suitably insulated with materials impervious to such liquid. Insulation material not impervious to oil is to be encased in sheet metal or an equivalent impervious sheath.

19.3.6 Ventilation

The spaces in which the oil fuel burning appliances are fitted are to be well ventilated.

19.3.7 Fire Protection

Boiler space is to be considered a machinery space of category A and is to be provided with fixed fire extinguishing system and other fire fighting equipment, as specified in 4-7-2/1.1.

19.5 Installation of Thermal Oil Heaters and Incinerators

In general, the installation of thermal oil heaters, incinerators and other fired equipment is to be in accordance with 4-4-1/19.3. Consideration should be given to installing thermal oil heaters in a space separated from the propulsion machinery space. Where fired equipment is installed in a space which is not continuously manned, it is also to be protected by a fire detection and alarm system.

19.7 Shipboard Trials

19.7.1 Boilers

All boilers are to be functionally tested after installation in the presence of a Surveyor. The test is to include proof of actuation of all safety devices. Safety valves are to be tested by boiler pressure accumulation test or its equivalent; see 4-4-1/9.1.8.

19.7.2 Pressure Vessels and Heat Exchangers

Pressure vessels and heat exchangers are to be functionally tested with the systems in which they form a part.

19.7.3 Thermal Oil Heaters and Incinerators

Thermal oil heaters, incinerators and other fired equipment are to be functionally tested after installation in the presence of a Surveyor.

PART

4

CHAPTER 4 Boilers, Pressure Vessels and Fired Equipment

SECTION 1 Appendix 1 – Rules for Design

1 General

1.1 Application

These requirements apply to the design and fabrication of boilers and pressure vessels. They are based on ASME Boiler and Pressure Vessel Code Section I and Section VIII Div. 1. As an alternative to these requirements, codes and standards indicated in 4-4-1/1.5 may be used.

1.3 Loads Other than Pressure

All boilers and pressure vessels designed with the provisions of this appendix are to take into account the hydrostatic head when determining the minimum thickness. Although not provided in the design rules of this appendix, additional stresses imposed by effects other than pressure or static head which increase the average stress by more than 10% of the allowable working stress are also to be taken into account. These effects include the static and dynamic weight of the unit and its content, external loads from connecting equipment, piping and support structure, thermal stress, fluctuating temperature or pressure conditions, as well as loads during hydrostatic testing.

1.5 Deformation Testing

Where the use of these Rules is impracticable due to the shape of a proposed pressure vessel, a submission may be made for approval of maximum allowable working pressure determined from a hydrostatic deformation test made on a full-sized sample. Consideration will be given to maximum allowable working pressure determined means of empirical equations and hydrostatic deformation test data in accordance with a recognized standard.

1.7 Plate and Pipe Thickness Tolerance

Plate and pipes are to be ordered not thinner than design thickness. Vessels made of plate furnished with mill under tolerance of not more than the smaller value of 0.25 mm (0.01 in.) or 6% of the ordered thickness may be used at the full design pressure for the thickness ordered.

3 Cylindrical Shell Under Internal Pressure

3.1 General Equations

Seamless and fusion-welded shells are to be in accordance with the following equations. The equations to be used are subject to 4-4-1A1/3.3 for boiler shells and to 4-4-1A1/3.5 for pressure vessel shells.

$$W = \frac{fSE(T - C)}{R + (1 - y)(T - C)} \quad \text{or} \quad T = \frac{WR}{fSE - (1 - y)W} + C \dots\dots\dots (1)$$

$$W = \frac{fSE\{(R_o - C)^2 - R^2\}}{(R_o - C)^2 + R^2} \dots\dots\dots (2)$$

$$W = \frac{2fSE(T - C)}{D - 2y(T - C)} \quad \text{or} \quad T = \frac{WD}{2fSE + 2yW} + C \quad \text{for } W \geq 6.9 \text{ bar} \dots\dots\dots (3)$$

where

- f = factor for units of measure = 10 (100, 1) for SI (MKS, US) units respectively
- W = maximum allowable working pressure; bar (kgf/cm², psi)
 For equation (3), W is not to be taken as less than 6.9 (7, 100) respectively for any condition of service or steel material
- S = maximum allowable working stress at the design temperature material, to be obtained from 4-4-1A1/Table 2; in N/mm² (kgf/mm², psi)
- E = efficiency of longitudinal joint or efficiency of ligaments between tube holes or efficiency of other closely spaced openings, whichever is the least; dimensionless; see 4-4-1A1/3.3.4, 4-4-1A1/3.3.5 and 4-4-1A1/3.5.4.
- T = minimum thickness of shell, mm (in.)
- R = inside radius of the weakest course of the shell; mm (in.)
- R_o = outside radius of the above shell under consideration; mm (in.)
- D = outside diameter of header or drum, mm (in.)
- C = corrosion allowance, see 4-4-1A1/3.3.6 and 4-4-1A1/3.5.2; mm (in.)
- y = coefficient having values as follows (values between temperatures may be interpolated):

	$\leq 482^{\circ}\text{C}$ 900°F	510°C 950°F	538°C 1000°F	566°C 1050°F	593°C 1100°F	$\geq 621^{\circ}\text{C}$ 1150°F
Ferritic steel	0.4	0.5	0.7	0.7	0.7	0.7
Austenitic steel	0.4	0.4	0.4	0.4	0.5	0.7

3.3 Boiler Shells

3.3.1 Thickness Less than One-half the Inside Radius

Where the thickness is less than one-half the inside radius, drums and headers are to be in accordance with Equation (1) or (3).

3.3.2 Thickness Greater than One-half the Inside Radius

The maximum allowable working pressure for parts of boilers of cylindrical cross section designed for temperatures up to that of saturated steam at critical pressure (374.1°C, 705.4°F) is to be determined using Equation (2).

3.3.3 Minimum Thickness

The minimum thickness of any boiler plate under pressures is to be 6.4 mm (0.25 in.), or when pipe over 127 mm (5 in.) OD is used in lieu of plate for the shell of cylindrical components under pressure, its minimum wall is to be 6.4 mm (0.25 in.).

3.3.4 Weld Seam Efficiency

The value of E is to be as follows and is to be used for calculations for the corresponding part of the shell.

- *Seamless shells:* $E = 1.00$.
- *Welded shells:* longitudinal and circumferential weld seams of boiler shells are to be accomplished by double-welded butt type, or equivalent, and are to be examined for their full length by radiography, $E = 1.00$.

3.3.5 Ligament Efficiency

3.3.5(a) *Longitudinal ligament.* When tube holes parallel to the longitudinal axis are such that the pitch of the tube on every row is equal, as in 4-4-1A1/Figure 1, E is to be given by the equation:

$$E = \frac{p - d}{p}$$

When the pitch of the tube holes on any one row is unequal, as in 4-4-1A1/Figures 2 and 3, E is to be given by the equation:

$$E = \frac{p_1 - nd}{p_1}$$

where

- p, p_1 = pitch of tubes; mm (in.)
- d = diameter of tube holes, mm (in.)
- n = number of tube holes in pitch p_1

3.3.5(b) *Diagonal ligament efficiency.* Where the tube holes are as shown in 4-4-1A1/Figure 4, the efficiency of such ligaments is to be determined from 4-4-1A1/Figure 5. When the diagonal efficiency is less than the efficiency determined from 4-4-1A1/3.3.5(a), it is to be used in calculating the minimum shell thickness.

FIGURE 1
Example of Tube Spacing With Pitch of Holes Equal in Every Row

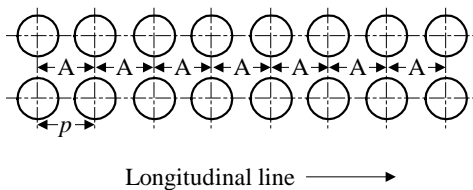

FIGURE 2
Example of Tube Spacing with Pitch of Holes Unequal in Every Second Row

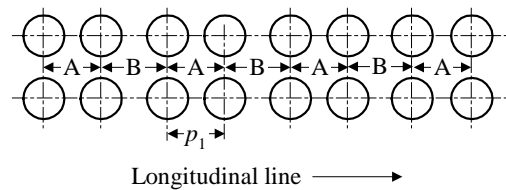

FIGURE 3
Example of Tube Spacing with Pitch of Holes Varying in Every Second Row

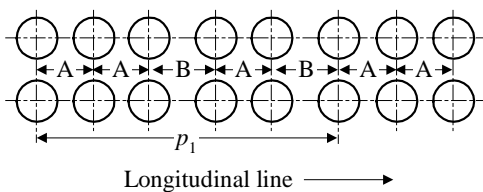

FIGURE 4
Example of Tube Spacing with Tube Holes on Diagonal Lines

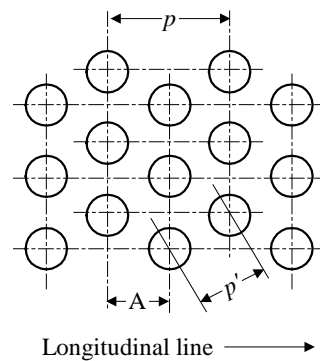
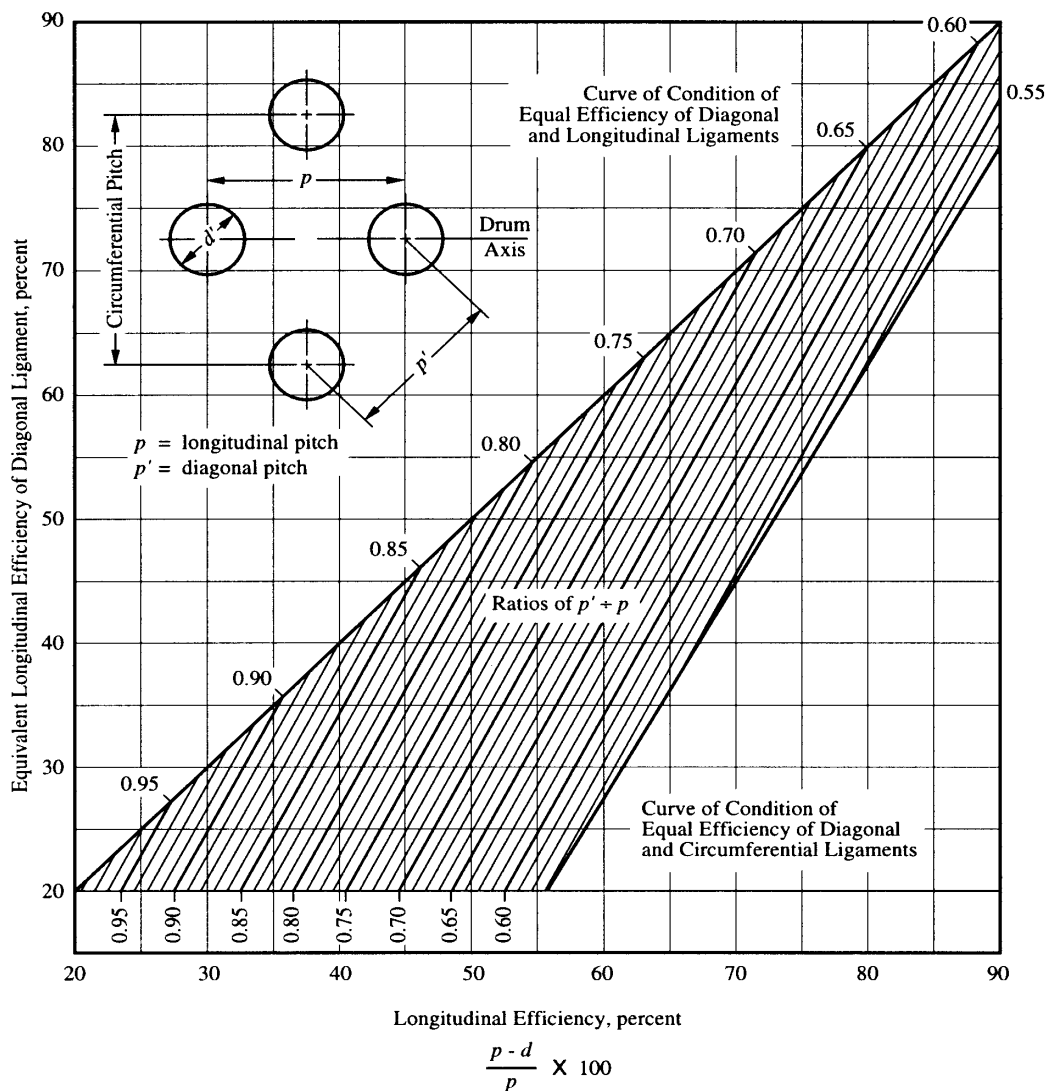

FIGURE 5
Diagram for Determination of Diagonal Efficiency



3.3.5(c) *Unsymmetrical ligament efficiency.* When tubes or holes are unsymmetrically spaced, the average ligament efficiency is to be not less than that given by the following requirements, which apply to ligaments between tube holes and not to single openings. This procedure may give lower efficiencies in some cases than those for symmetrical groups which extend a distance greater than the inside diameter of the shell as covered under 4-4-1A1/3.3.5(a) and 4-4-1A1/3.3.5(b). When this occurs, the efficiencies computed under 4-4-1A1/3.3.5(a) and 4-4-1A1/3.3.5(b) are to be used.

- i) For a length equal to the inside diameter of the drum for the position which gives the minimum efficiency, the efficiency is to be not less than that on which the maximum allowable pressure is based. When the diameter of the drum exceeds 1525 mm (60 in.), the length is to be taken as 1525 mm (60 in.) in applying this requirement.
- ii) For a length equal to the inside radius of the drum for the position which gives the minimum efficiency, the efficiency is to be not less than 80% of that on which the maximum allowable pressure is based. When the radius of the drum exceeds 762 mm (30 in.), the length is to be taken as 762 mm (30 in.) in applying this requirement.

iii) For holes placed longitudinally along a drum but which do not come in a straight line, the above Rules for calculating efficiency are to hold, except that the equivalent longitudinal width of a diagonal ligament is to be used. To obtain the equivalent width, the longitudinal pitch of the two holes having a diagonal ligament is to be multiplied by the efficiency of the diagonal ligament as given in 4-4-1A1/Figure 6.

3.3.5(d) *Circumferential ligament efficiency.* The efficiency of circumferential ligaments is to be determined in a manner similar to that of the longitudinal ligaments in 4-4-1A1/3.3.5(a) and is to be equal to at least one-half the efficiency of the latter.

FIGURE 6
Diagram for Determining Efficiency of Diagonal Ligaments
in Order to Obtain Equivalent Longitudinal Efficiency

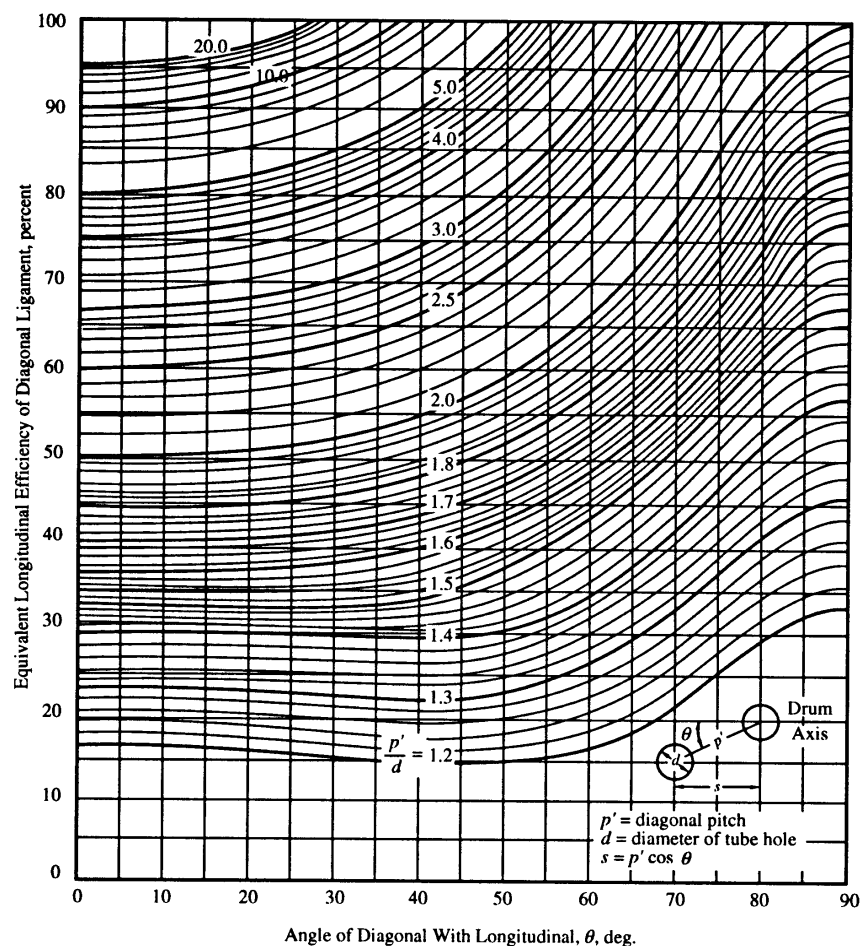

3.3.6 Corrosion Allowance, C

A corrosion allowance is to be added if corrosion or erosion is expected. The value is to be specified in the submitted plans.

3.5 Pressure Vessel Shells

3.5.1 Maximum Allowable Working Pressure

The maximum allowable working pressure is to be determined using Equation (1) when W does not exceed $3.85SE$ (SI units), $38.5SE$ (MKS units), or $0.385SE$ (US units) or when the thickness does not exceed one half of the inside radius. Where the thickness of the shell exceeds one-half of the inside radius, or when W exceeds $3.85SE$ (SI units) pressure vessels designed for pressures above 207 bar (210 kgf/cm², 3000 psi), Equation (2) is to be used.

3.5.2 Corrosion Allowance

A corrosion allowance, C , of not less than one-sixth of the calculated thickness is to be used in determining the thickness of pressure vessels intended for air, steam or water or any combination thereof when they are designed with S values taken from 4-4-1A1/Table 2 and the minimum required thickness is less than 6.4 mm (0.25 in.), except that the sum of the calculated thickness and corrosion allowance need not exceed 6.4 mm (0.25 in.). This corrosion allowance is to be provided on the surface in contact with the substance. A corrosion allowance may be omitted for the following cases:

- When 0.8 of the S values taken from 4-4-1A1/Table 2 are used in the design or,
- When values of E in column (c) of 4-4-1A1/Table 1 are used in the design, or
- When seamless vessel parts are designed with $E = 0.85$.

3.5.3 Minimum Thickness

Plates are not to be less than 2.4 mm (³/₃₂ in.) thick after forming and without allowance for corrosion.

3.5.4 Weld Joint Efficiency

Efficiencies for welded, unfired pressure vessels are to be determined from 4-4-1A1/Table 1. For Group I pressure vessels, longitudinal and circumferential weld seams of shell are to be accomplished by double-welded butt type, or equivalent, and are to be examined for their full length by radiography, in which case, $E = 1.00$.

5 Unstayed Heads

5.1 Torispherically and Hemispherically Dished Heads

5.1.1 Minimum Thickness

The minimum thickness for heads without manholes or handholes and having the pressure on the concave side is to be determined by the following equation. See 4-4-1A1/Figures 7u and 7v. For heads having pressure on the convex side, see 4-4-1A1/5.1.7.

$$T = \frac{WRM}{2fSE - 0.2W} + C$$

$$M = 0.25 \left(3 + \sqrt{\frac{R}{r}} \right)$$

$M = 1.00$ for hemispherically dished heads

where

- T = minimum thickness of the head; mm (in.)
 W = maximum working pressure; bar (kgf/cm², psi)
 R = radius to which the head is dished, measured on the concave side, see 4-4-1A1/5.1.2; mm (in.)
 r = knuckle radius of head, see 4-4-1A1/5.1.3; mm (in.)

- S = maximum allowable working stress, see 4-4-1A1/5.1.4; N/mm² (kgf/mm², psi)
 E = lowest efficiency of any joint in the head, see 4-4-1A1/5.1.5
 C = corrosion allowance, see 4-4-1A1/5.1.6; mm (in.)
 f = factor = 10 (100, 1) for SI (MKS, US) units, respectively

5.1.2 Dish Radius

The radius to which a head is dished is to be not greater than the outside diameter of the flanged portion of the head.

5.1.3 Knuckle Radius

The inside radius of the flange formed on any head for its attachment to the shell plate is to be

- Not less than three (3) times the thickness of the head, and
- In the case of dished heads, not less than 6% of the outside diameter of the flanged portion of the head.

5.1.4 Maximum Allowable Working Stress

The maximum allowable working stress may be taken from 4-4-1A1/Table 2, except that in the case of pressure vessels where spot radiography is not carried out the maximum allowable unit working stress is not to exceed 0.85 of the appropriate S value in 4-4-1A1/Table 2.

5.1.5 Joint Efficiency

For boilers and Group I pressure vessels, weld seams in the heads are to be of the double-welded butt type and are to be fully radiographed, thus, $E = 1$. For seamless heads, use $E = 1.00$. For Group II pressure vessels, use E values in 4-4-1A1/Table 1.

Head to shell seams are to be considered circumferential seams of shell and are to be dealt with as in 4-4-1A1/3.3.4 for boiler and 4-4-1A1/3.5.4 for Group I pressure vessels. However, for hemispherical heads without a skirt, where the attachment of the head to the shell is at the equator, the head to shell joint is to be included in evaluating the joint efficiency of the head.

5.1.6 Corrosion Allowance

The values of the corrosion allowance are to be in accordance with 4-4-1A1/3.3.6 for boilers and 4-4-1A1/3.5.2 for pressure vessels.

5.1.7 Heads Having Pressure on the Convex Side

The minimum thickness of a dished head having pressure on the convex side is not to be less than the thickness calculated by the equation in 4-4-1A1/5.1.1 using $1.67 \times W$, where W is the maximum working pressure on the convex side.

5.3 Ellipsoidal Heads

5.3.1 Heads with Pressure on the Concave Side

The minimum thickness of a dished head of an ellipsoidal form having pressure on the concave side is to be in accordance with the following equation:

$$T = \frac{WDK}{2fSE - 0.2W} + C$$

$$K = \frac{1}{6} \left[2 + \left(\frac{D}{2h} \right)^2 \right]$$

where

- h = inside depth of the head not including the skirt; mm (in.) (see 4-4-1A1/Figure 7t)
 D = inside diameter of the head skirt; mm (in.) (see 4-4-1A1/Figure 7t)

T , W , S , E , C and f are as defined in 4-4-1A1/5.1.

5.3.2 Heads with Pressure on the Convex Side

The minimum thickness of a dished head having pressure on the convex side is not to be less than the thickness calculated by the equation in 4-4-1A1/5.3.1 using $1.67 \times W$, where W is the maximum working pressure on the convex side.

5.5 Heads with Access Openings

5.5.1 Torispherically- and Hemispherically-dished Heads

When a dished head has a manhole or other access opening exceeding 152 mm (6 in.) in any dimension and it is not reinforced in accordance with 4-4-1A1/7, the head thickness determined by 4-4-1A1/3.1, using $M = 1.77$, is to be increased by 15%, but in no case by less than 3.2 mm (0.125 in.).

5.5.2 Ellipsoidal Heads

If a flanged-in manhole is placed in an ellipsoidal head, the thickness is to be the same as for a spherically dished head with a dish radius equal to 0.8 of the inside diameter of the shell and with added thickness for the manhole as called for in 4-4-1A1/5.5.1.

5.5.3 Manhole Flange Depth

A flanged-in manhole opening in a dished head is to be flanged to a depth of not less than three times the required thickness of the head for plate up to 38 mm (1.5 in.) in thickness. For plate exceeding 38 mm (1.5 in.), the depth is to be the required thickness of the plate plus 76 mm (3 in.). The flange depth is to be measured from the outside of the opening along the major axis.

5.5.4 Reinforced Access Openings

When an access opening is reinforced in accordance with 4-4-1A1/7.3, the head thickness may be the same as for a blank head.

5.7 Unstayed Flat Heads

5.7.1 General

The minimum thickness for unstayed flat heads is to conform to the provisions of 4-4-1A1/5.7. These provisions apply to both circular and noncircular heads and covers. Some acceptable types of flat heads and covers are shown in 4-4-1A1/Figure 7. In this figure, the dimensions of the component parts and the dimensions of the welds are exclusive of extra metal required by corrosion allowance.

5.7.2 Definitions of Symbols Used

B	=	total bolt load, as further defined hereunder; N (kgf, lbf)
C	=	corrosion allowance, see 4-4-1A1/3.3.6 for boilers and 4-4-1A1/3.5.2 for pressure vessels
D	=	long span of noncircular heads or covers measured perpendicular to short span; m (in.)
d	=	diameter, or short span, measured as indicated in 4-4-1A1/Figure 7, mm (in.)
f	=	factor = 10 (100, 1) for SI (MKS, US) units, respectively
h_g	=	gasket moment arm, equal to the radial distance from the center line of the bolts to the line of the gasket reaction, as shown in 4-4-1A1/Figures 7j and 7k; mm (in.)
K	=	factor depending on the method of attachment of the head; on the shell, pipe or header dimensions; and on other items as listed in 4-4-1A1/5.7.3(d) below, dimensionless
L	=	perimeter of noncircular bolted head measured along the centers of the bolt holes; mm (in.)

ℓ	=	length of flange of flanged heads, measured from the tangent line of knuckle, as indicated in 4-4-1A1/Figure 7a, c-1 and c-2; mm (in.)
m	=	t_r/t_s
r	=	inside corner radius on the head formed by flanging or forging; mm (in.)
S	=	maximum allowable stress value from 4-4-1A1/Table 2; N/mm ² (kgf/mm ² , psi)
t	=	minimum required thickness of flat head or cover; mm (in.)
t_e	=	minimum distance from beveled end of drum, pipe or header, before welding, to outer face of head, as indicated in 4-4-1A1/Figure 7i; mm (in.)
t_f	=	actual thickness of the flange on a forged head, at the large end, as indicated in 4-4-1A1/Figure 7b-1, mm (in.)
t_h	=	actual thickness of flat head or cover; mm (in.)
t_ℓ	=	throat dimension of the closure weld, as indicated in 4-4-1A1/Figure 7r; mm (in.)
t_r	=	required thickness of seamless shell, pipe or header, for pressure; mm (in.)
t_s	=	actual thickness of shell, pipe or header; mm (in.)
t_w	=	thickness through the weld joining the edge of a head to the inside of a drum, pipe or header, as indicated in 4-4-1A1/Figure 7g; mm (in.)
W	=	maximum allowable working pressure; bar (kgf/cm ² , psi)
Z	=	factor for noncircular heads and covers that depends on the ratio of short span to long span, as given in 4-4-1A1/5.7.3(c).

FIGURE 7
Some Acceptable Types of Unstayed Heads and Covers

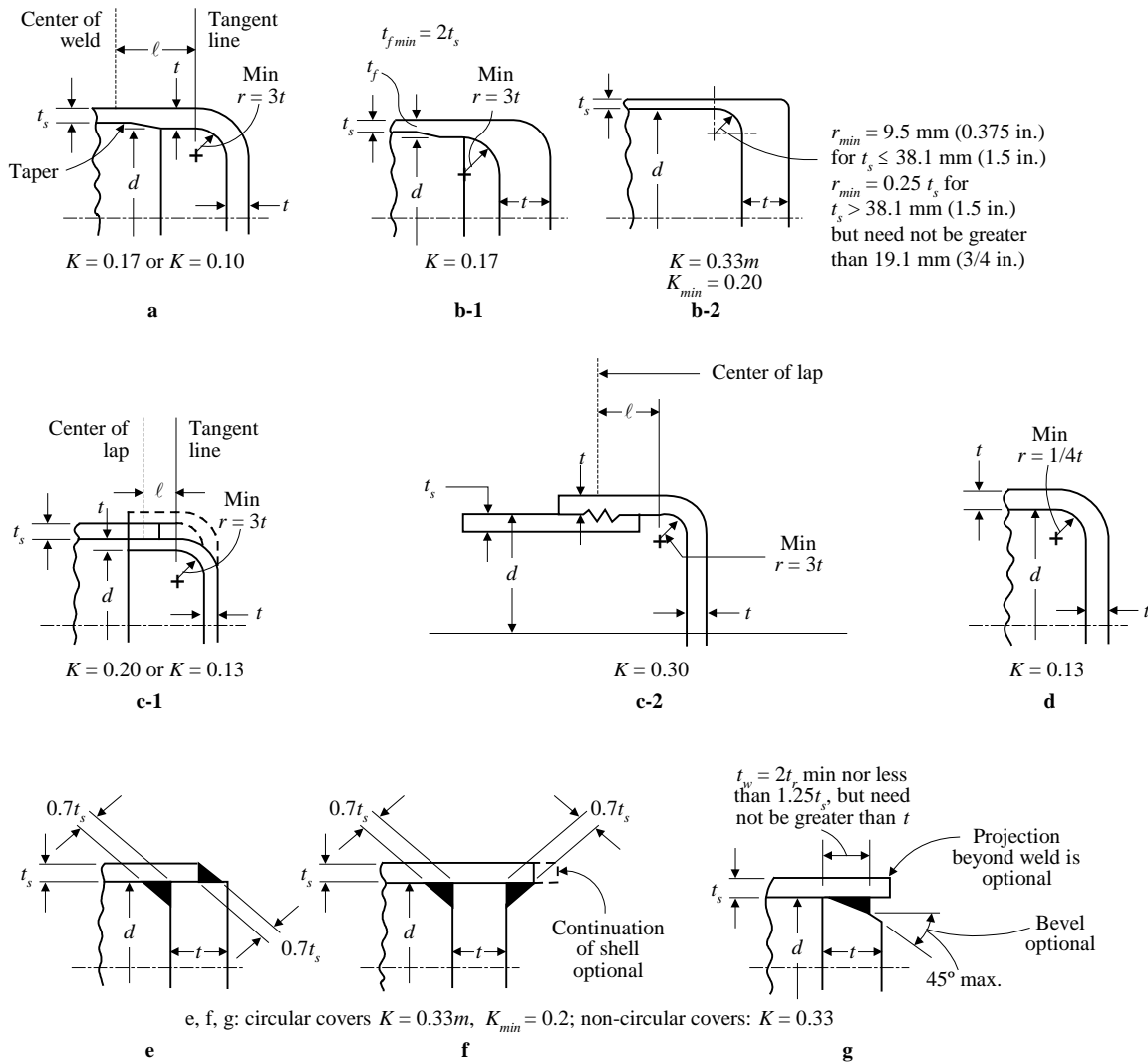
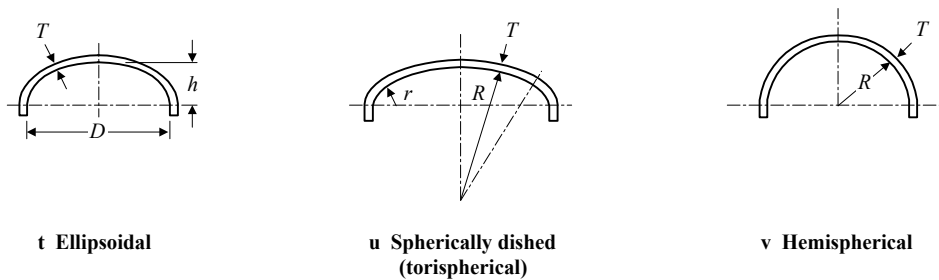
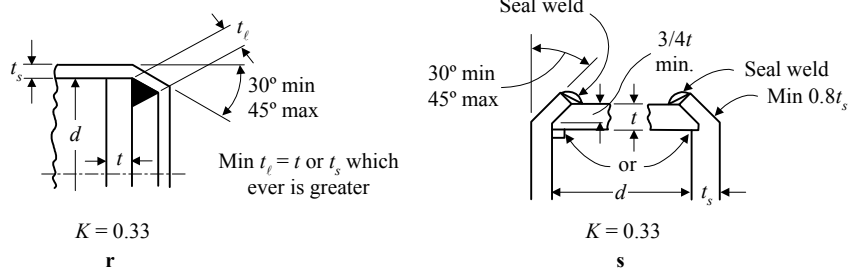
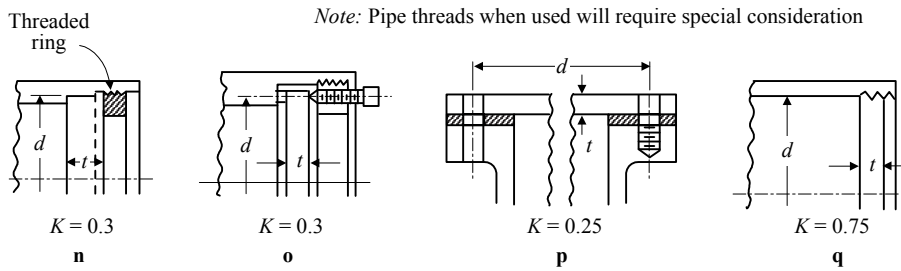
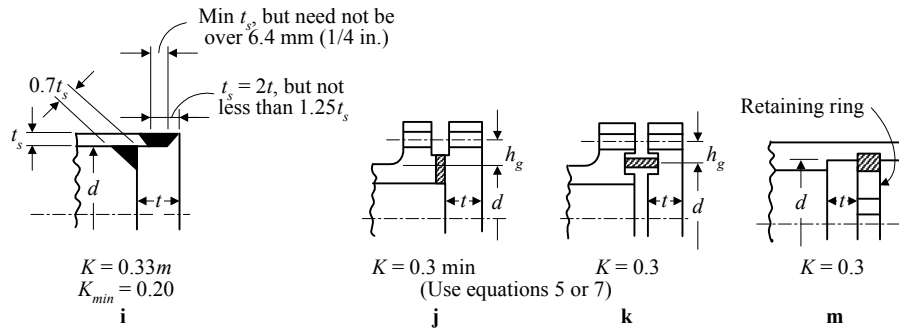

FIGURE 7 (continued)
Some Acceptable Types of Unstayed Heads and Covers



5.7.3 Equations for Minimum Thickness

The following provisions are to be used to evaluate the minimum required thickness for flat unstayed heads, covers, and blind flanges. The equations in 4-4-1A1/5.7.3(b) through 4-4-1A1/5.7.3(d) allow for pressure and bolt loading only. Greater thickness may be necessary if deflection would cause leakage at threaded or gasketed joints.

5.7.3(a) *Standard blind flanges.* Circular blind flanges of ferrous materials conforming to ANSI B16.5 will be acceptable for the pressure-temperature ratings specified in the Standard. These flanges are shown in 4-4-1A1/Figures 7j and 7k. Blind flanges complying with other compatible recognized national or international standards may be submitted for approval.

5.7.3(b) *Circular heads.* The minimum required thickness of flat unstayed circular heads, covers and blind flanges is to be calculated by the following equation:

$$t = d \sqrt{\frac{KW}{fS}} + C \dots\dots\dots(4)$$

except when the head, cover or blind flange is attached by bolts causing an edge moment (see 4-4-1A1/Figures 7j and 7k), in which case the thickness is to be calculated by the following equation:

$$t = d \sqrt{\frac{KW}{fS} + \frac{1.9Bh_g}{Sd^3}} + C \dots\dots\dots(5)$$

When using Equation 5, the thickness *t* is to be calculated for both initial tightening and design conditions, and the greater of the two values is to be used. For initial tightening conditions, the value for *S* at room temperature is to be used, and *B* is to be the average of the required bolt load and the load available from the bolt area actually used. For design conditions, the value for *S* at design temperature is to be used, and *B* is to be the sum of the bolt loads required to resist the end-pressure load and to maintain tightness of the gasket.

5.7.3(c) *Noncircular heads.* Flat unstayed heads, covers or blind flanges may be square, rectangular, elliptical, obround, segmental or otherwise noncircular. Their required thickness is to be calculated by the following equations:

$$t = d \sqrt{\frac{ZKW}{fS}} + C \dots\dots\dots(6)$$

$$Z = 3.4 - 2.4 \frac{d}{D} \text{ with } Z \leq 2.5$$

except where the noncircular heads, covers, or blind flanges are attached by bolts causing a bolt edge moment (see 4-4-1A1/Figures 7j and 7k), in which case the required thickness is to be calculated by the following equation:

$$t = d \sqrt{\frac{ZKW}{fS} + \frac{6Bh_g}{SLd^2}} + C \dots\dots\dots(7)$$

When using Equation 7, the thickness *t* is to be calculated for both initial tightening and design conditions, as prescribed for Equation 5.

5.7.3(d) *K values.* For the types of construction shown in 4-4-1A1/Figure 7, the values of *K* to be used in Equations 4, 5, 6, and 7 are to be as follows.

- i) 4-4-1A1/Figure 7a: *K* = 0.17 for flanged circular and noncircular heads, forged integral with or butt-welded to the shell, pipe or header. The inside corner radius is not to be less than three times the required head thickness, with no special requirement with regard to the length of the flange. Welding is to meet all of the requirements for circumferential joints given in Section 2-4-2.

$K = 0.10$ for circular heads, when the flange length for heads of the above design is not less than that given in the following equation and the taper is no greater than 1:3:

$$\ell = \left(1.1 - \frac{0.8t_s^2}{t_h^2} \right) \sqrt{dt_h} \dots\dots\dots (8)$$

ii) 4-4-1A1/Figure 7b-1: $K = 0.17$ for circular and noncircular heads, forged integral with or butt-welded to the shell, pipe or header. The corner radius on the inside is not less than three times the thickness of the flange and welding meets all of the requirements for circumferential joints given in Section 2-4-2.

iii) 4-4-1A1/Figure 7b-2: $K = 0.33m$ but not less than 0.20 for forged circular and noncircular heads integral with or butt welded to the vessel, where the flange thickness is not less than the shell thickness and the corner radius on the inside is not less than the following.

$$r_{\min} = 9.5 \text{ mm (0.375 in.) for } t_s \leq 38.1 \text{ mm (1.5 in.)}$$

$$r_{\min} = 0.25t_s \text{ for } t_s > 38.1 \text{ mm (1.5 in.) but need not be } >19.1 \text{ mm (0.75 in.)}$$

The welding is to comply with the requirements for circumferential joints given in Section 2-4-2.

iv) 4-4-1A1/Figure 7c-1: $K = 0.13$ for circular heads lapwelded or brazed to the shell with the corner radius not less than $3t$ and ℓ not less than required by Equation 8 and where the welds meet the requirements of 2-4-2/7.11.

$K = 0.20$ for circular and noncircular lapwelded or brazed construction as above, but with no special requirement with regard to ℓ .

v) 4-4-1A1/Figure 7c-2: $K = 0.30$ for circular flanged plates screwed over the end of the shell, pipe or header, with the inside corner radius not less than $3t$, in which the design of the threaded joint against failure by shear, tension or compression, resulting from the end force due to pressure, is based on a factor of safety of at least four (4), and the threaded parts are at least as strong as the threads for standard piping of the same diameter. Seal welding may be used, if desired.

vi) 4-4-1A1/Figure 7d: $K = 0.13$ for integral flat circular heads when the dimension d does not exceed 610 mm (24 in.), the ratio of thickness of the head to the dimension d is not less than 0.05 nor greater than 0.25, the head thickness t_h is not less than the shell thickness t_s , the inside corner radius is not less than $0.25t$, and the construction is obtained by special techniques of upsetting and spinning the end of the shell, pipe or header, such as employed in closing header ends.

vii) 4-4-1A1/Figure 7e, f and g:

$K = 0.33m$ but not less than 0.2 for circular plates, welded to the inside of a drum, pipe or header, and otherwise meeting the requirements for the respective types of fusion-welded boiler drums, including stress relieving when required for the drum, but omitting radiographic examination. If m is smaller than 1, the shell thickness t_s is to extend to a length of at least $2\sqrt{dt}$ from the inside face of the head. The throat thickness of the fillet welds in 4-4-1A1/Figure 7e and f is to be at least $0.7t_s$. The size of the weld t_w in 4-4-1A1/Figure 7g is to be not less than two times the required thickness of a seamless shell nor less than 1.25 times the nominal shell thickness, but need not be greater than the head thickness. The weld is to be deposited in a welding groove with the root of the weld at the inner face of the head as shown in the figure. Radiographic examination is not required for any of the weld joints shown in the figures.

$K = 0.33$ for noncircular plates, welded to the inside of a drum, pipe or header, and otherwise meeting the requirements for the respective types of fusion-welded boiler drums, including stress-relieving when required for the drum, but omitting radiographic examination. The throat thickness of the fillet welds in 4-4-1A1/Figure 7e and f is to be at least $0.7t_s$. The size of the weld t_w in 4-4-1A1/Figure 7g is to be not less than two times the required thickness of a seamless shell nor less than 1.25 times the nominal shell thickness, but need not be greater than the head thickness. The weld is to be deposited in a welding groove with the root of the weld at the inner face of the head as shown in the figure. Radiographic examination is not required for any of the weld joints shown in the figures.

- viii) 4-4-1A1/Figure 7i: $K = 0.33m$ but not less than 0.2 for circular plates welded to the end of the drum, pipe or header, when an inside weld with minimum throat thickness of $0.7t_s$ is used, and when the beveled end of the drum, pipe or header is located at a distance not less than $2t_r$, nor less than $1.25t_s$ from the outer face of the head. The width at the bottom of the welding groove is to be at least equal to t_s , but need not be over 6.4 mm (0.25 in.). Radiographic examination is not required for any of the weld joints shown in the figure.
- ix) 4-4-1A1/Figure 7j and k: $K = 0.3$ for circular and noncircular heads and covers bolted to the shell, flange or side plate, as indicated in the figures. Note that Equation 5 or 7 is to be used because of the extra moment applied to the cover by the bolting. When the cover plate is grooved for a peripheral gasket, as shown in 4-4-1A1/Figure 7k, the net cover-plate thickness under the groove or between the groove and the outer edge of the cover plate is to be not less than:

$$d \sqrt{\frac{1.9Bh_g}{Sd^3}} \quad \text{for circular heads and covers,}$$

nor less than

$$d \sqrt{\frac{6Bh_g}{SLd^2}} \quad \text{for noncircular heads and covers.}$$

- x) 4-4-1A1/Figure 7m, n and o: $K = 0.3$ for a circular plate inserted into the end of a shell, pipe or header, and held in place by a positive mechanical locking arrangement, and when all possible means of failure either by shear, tension, compression or radial deformation, including flaring, resulting from pressure and differential thermal expansion, are resisted with a factor of safety of at least four (4). Seal welding may be used, if desired.
- xi) 4-4-1A1/Figure 7p: $K = 0.25$ for circular and noncircular covers bolted with a full-face gasket to shells, flanges or side plates.
- xii) 4-4-1A1/Figure 7q: $K = 0.75$ for circular plates screwed into the end of a shell, pipe or header, having an inside diameter d not exceeding 305 mm (12 in.); or for heads having an integral flange screwed over the end of a shell, pipe or header, having an inside diameter d not exceeding 305 mm (12 in.); and when the design of the threaded joint against failure by shear, tension, compression or radial deformation, including flaring, resulting from pressure and differential thermal expansion, is based on a factor of safety of at least four (4). A tapered pipe thread will require special consideration. Seal welding may be used, if desired.
- xiii) 4-4-1A1/Figure 7r: $K = 0.33$ for circular plates having a dimension d not exceeding 457 mm (18 in.), inserted into the shell, pipe or header, and welded as shown, and otherwise meeting the requirements for fusion-welded boiler drums, including stress-relieving but omitting radiographic examination. The end of the shell, pipe or header, is to be crimped over at least 30° but not more than 45° . The crimping is to be done cold only when this operation will not injure the metal. The throat of the weld is to be not less than the thickness of the flat head or the shell, pipe or header, whichever is greater. Radiographic examination is not required for any of the weld joints shown in the figure.

- xiv) 4-4-1A1/Figure 7s: $K = 0.33$ for circular beveled plates having a diameter d not exceeding 457 mm (18 in.), inserted into a shell, pipe or header, the end of which is crimped over at least 30° but not more than 45° , and when the undercutting for seating leaves at least 80% of the shell thickness. The beveling is to be not less than 75% of the head thickness. The crimping is to be done when the entire circumference of the cylinder is uniformly heated to the proper forging temperature for the material used. For this construction, the ratio t_s/d is to be not less than the ratio:

$$\frac{W}{10S} \left(\frac{W}{100S}, \frac{W}{S} \right) \text{ for SI (MKS, US) units, respectively, nor less than 0.05.}$$

The maximum allowable working pressure, W , for this construction is not to exceed:

$$\frac{50.8S}{d} \left(\frac{508S}{d}, \frac{S}{5d} \right) \text{ for SI (MKS, US) units respectively.}$$

Radiographic examination is not required for any of the weld joints shown in the figure.

5.9 Stayed Flat Heads

5.9.1 General

Surfaces required to be stayed include flat plates such as heads or portions thereof, wrapper sheets, furnace plates, side sheets, tube plates, combustion chamber plates, etc., also curved plates with pressure on the convex side which are not self-supporting. No plates less than 7.9 mm ($5/16$ in.) in thickness are to be used in stayed surface construction.

5.9.2 Plates Supported by Stay Bars

The minimum required thickness of plates supported by stay bars is to be determined by the following equation:

$$T = p \sqrt{\frac{KW}{fS}}$$

where

- T = minimum thickness of the plate; mm (in.)
 W = maximum working pressure; bar (kgf/cm², psi)
 p = maximum pitch measured between the centers of stays in different rows, which may be horizontal and vertical, or radial and circumferential; mm (in.)
 f = factor = 10 (100, 1) for SI (MKS, US) units, respectively
 S = maximum allowable working stress; N/mm² (kgf/mm², psi)
 K = factor depending on the kind of service to which the plate is subjected and the method of construction, as given below:

- i) For plates exposed to products of combustion:

- K = 0.23 for plates under 11.1 mm ($7/16$ in.)
 = 0.22 for plates 11.1 mm ($7/16$ in.) and over
 = 0.21 for plates under 11.1 mm ($7/16$ in.) reinforced by doubling strips, the width of the doubling strip to be not less than $2/3$ of the maximum pitch of the stays and the thickness is to be not less than $2/3$ of the thickness of the plate
 = 0.20 for plates 11.1 mm ($7/16$ in.) and over reinforced by doubling strips, the width of the doubling strip to be not less than $2/3$ of the maximum pitch of the stays and the thickness is to be not less than $2/3$ of the thickness of the plate

ii) For plates not exposed to products of combustion:

K	=	0.20	for plates under 11.1 mm ($7/16$ in.)
	=	0.19	for plates 11.1 mm ($7/16$ in.) and over
	=	0.18	for plates under 11.1 mm ($7/16$ in.) reinforced by doubling strips, the width of the doubling strip to be not less than $2/3$ of the maximum pitch of the stays and the thickness is to be not less than $2/3$ of the thickness of the plate
	=	0.17	for plates 11.1 mm ($7/16$ in.) and over reinforced by doubling strips, the width of the doubling strip to be not less than $2/3$ of the maximum pitch of the stays and the thickness is to be not less than $2/3$ of the thickness of the plate

5.9.3 Plates Supported by Stay Tubes

The minimum required thickness of plates supported by stay tubes is to be determined by the following equation:

$$T = \sqrt{\frac{KW}{fS} \left(p^2 - \frac{\pi}{4} d_o^2 \right)}$$

where

d_o = outside diameter of the tube; mm (in.)

T, p, K, W, f and S are as defined above.

5.9.4 Tube Plates Subjected to Compressive Stresses

For flat tube plates having the ligaments subjected to compressive stresses, such as tube plates of combustion chambers with the tops supported by girders, the minimum required thickness of plates is to be determined by the following equation:

$$T = \frac{LPW}{2fS(P-d)}$$

where

P = least horizontal pitch of tubes, mm (in.)

L = total length of the combustion chamber over the tube plate and back sheet, mm (in.)

d = inside diameter of plain tube, mm (in.)

T, W, S and f are as defined above.

5.9.5 Stays

The minimum required cross sectional area of stays is to be determined by the following equation:

$$A_r = \frac{1.1AW}{fS}$$

where

A_r = required cross sectional area of stay, mm² (in²)

A = area supported by the stay, mm² (in²)

W = maximum working pressure, bar (kgf/cm², psi)

f = factor = 10 (100, 1) for SI (MKS, US) units, respectively

S = maximum allowable working stress, N/mm² (kgf/mm², psi)

7 Openings and Reinforcements

7.1 General

7.1.1 Application

The following apply to all openings in shells, headers or heads, except as otherwise provided in 4-4-1A1/7.1.2. The reinforcement requirements apply to openings not exceeding the following dimensions.

- For shells 1525 mm (60 in.) diameter or less, $\frac{1}{2}$ the shell diameter but not over 508 mm (20 in.).
- For shells over 1525 mm (60 in.) diameter, $\frac{1}{3}$ the shell diameter but not over 1016 mm (40 in.).

Reinforcement of larger openings is to be submitted for specific approval.

FIGURE 8
Example of Reinforced Opening

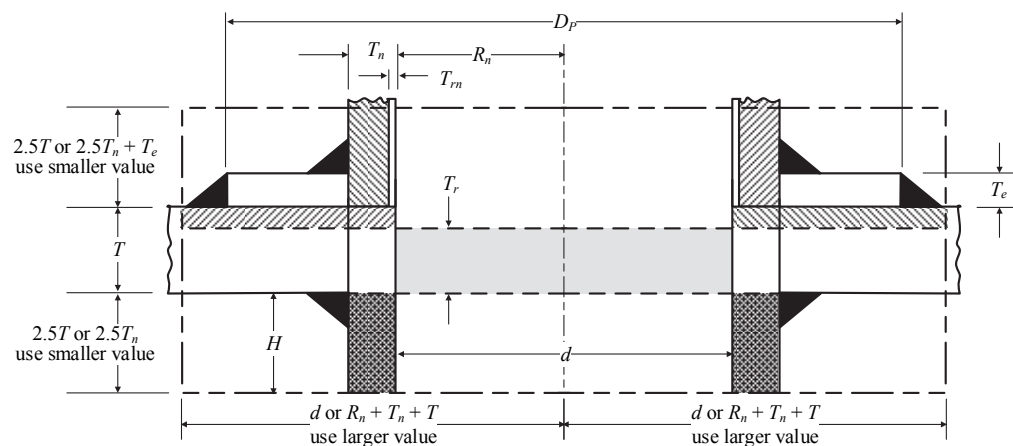

Without Reinforcing Element

	$= A$	$= d \times T_r \times F$
	$= A_1$	$= (ET - FT_r)(d - R_n)2 = (ET - FT_r)d$
	$= A_2$	or $= (ET - FT_r)(R_n + T_n + T - R_n)2 = (ET - FT_r)(T_n + T)2$
	$= A_3$	$= (T_n - T_{rn})2.5T \times 2 = (T_n - T_{rn})5T$
	$= A_3$	or $= (T_n - T_{rn})2.5T_n \times 2 = (T_n - T_{rn})5T_n$
	$= A_3$	$= (T_n)2H$
	$= A_4$	$= \text{Area of welds}$

If $A_1 + A_2 + A_3 + A_4 \geq A$, opening is adequately reinforced.

If $A_1 + A_2 + A_3 + A_4 < A$, opening is not adequately reinforced so reinforcing element is to be added and/or thicknesses are to be increased.

With Reinforcing Element

A_1, A_3, A_4 same as without reinforcing element.

$2.5T_n$ is measured from the top surface of the reinforcing element.

A_2 becomes the smaller of $(T_n - T_{rn})5T$ or $(T_n - T_{rn})(5T_n + 2T_e)$.

Area of reinforcing element $= (D_p - d - 2T_n)T_e = A_5$

If $A_1 + A_2 + A_3 + A_4 + A_5 \geq A$ opening is adequately reinforced.

7.1.2 Openings in Definite Pattern

Openings in a definite pattern such as tube holes may be designed in accordance with the requirements of 4-4-1A1/3.3.5, provided the largest hole in the group does not exceed that permitted by the following equations.

$$d = 8.08 \cdot \sqrt[3]{DT(1-K)} \text{ mm} \quad \text{or} \quad d = 2.75 \cdot \sqrt[3]{DT(1-K)} \text{ in.}$$

subject to the following:

i) $d \leq 203 \text{ mm (8 in.)}$

ii) $K = \frac{WD}{1.6fST}$ when design with 0.8 of S value from 4-4-1A1/Table 2

iii) $K = \frac{WD}{1.82fST}$ when design with actual S values from 4-4-1A1/Table 2

iv) if $DT > 129,000 \text{ mm}^2 (200 \text{ in}^2)$, use $DT = 129,000 \text{ mm}^2 (200 \text{ in}^2)$

where

- d = maximum allowable diameter of opening; mm (in.)
- D = outside diameter of shell; mm (in.)
- T = thickness of plate; mm (in.)
- W = maximum working pressure; bar (kgf/cm², psi)
- S = maximum allowable working stress from 4-4-1A1/Table 2; N/mm² (kgf/mm², psi)
- f = factor = 10 (100, 1) for SI (MKS, US) units, respectively

See also 4-4-1A1/7.11.3 concerning reinforcement between tube holes.

7.1.3 Calculations

Calculations demonstrating compliance with 4-4-1A1/7.3 are to be made for all openings, except:

- i) Where there are single openings in the shell or headers with the diameter of the opening less than that permitted by the equation in 4-4-1A1/7.1.2, or
- ii) Where single openings of not larger than 50 mm (2 in.) nominal pipe size are made in shells or headers having an inside diameter not less than four times the diameter of the opening.

Tube holes arranged in a definite pattern are also to comply with 4-4-1A1/7.3 when the tube hole diameter is greater than that permitted by the equation in 4-4-1A1/7.1.2.

7.1.4 Openings in or Adjacent to Welds

Any opening permitted in these Rules may be located in a welded joint that has been stress-relieved and radiographed.

7.3 Reinforcement Requirements

7.3.1 Shells and Formed Heads

Reinforcement is to be provided in amount and distribution such that the area requirements for reinforcement are satisfied for all planes through the center of the opening and normal to the vessel surface. The total cross-sectional area of reinforcement in any given plane is to be not less than obtained from the following equation:

$$A = FdT_r$$

where

A = required reinforcement (see 4-4-1A1/Figure 8); mm² (in²)

- F = a correction factor which compensates for the variation in pressure stresses on different planes with respect to the axis of a vessel. A value of 1.0 is to be used if the chosen plane containing the opening (or the nozzle) axis coincides with the vessel's longitudinal axis. Otherwise, the values of F is to be as given in 4-4-1A1/Figure 9.
- d = diameter of the finished opening in the given plane; mm (in.)
- T_r = the minimum required thickness, exclusive of the corrosion allowance, C , of a seamless shell, header, formed head or flat head, as calculated by formulas in 4-4-1A1/3.1, 4-4-1A1/5.1, 4-4-1A1/5.3, or 4-4-1A1/5.7 as appropriate, using $E = 1$; mm (in.), except that:
- for dished heads when the opening and its reinforcement are entirely within the spherical portion, T_r is the thickness exclusive of the corrosion allowance required by the equation given in 4-4-1A1/5.1 using $M = 1$; and
 - for elliptical heads as defined in 4-4-1A1/5.3 when the opening and its reinforcement are located entirely within a circle, the center of which coincides with the center of the head and the diameter of which is 0.8 of the inside shell diameter, T_r is the thickness, exclusive of the corrosion allowance required by the equation given in 4-4-1A1/5.1 using $M = 1$ and $R = 0.9$ of the inside diameter of the shell

FIGURE 9
Chart for Determining Value of F

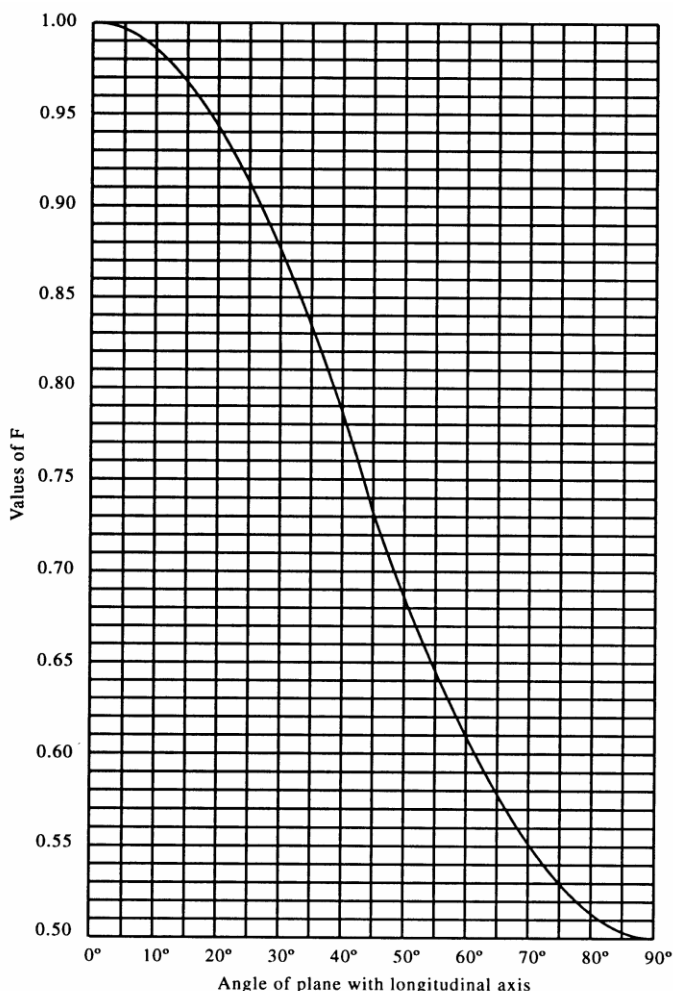

7.3.2 Flat Heads

Flat heads that have an opening with a diameter that does not exceed one-half of the head diameter, or shortest span, are to have a total cross-sectional area of reinforcement not less than that given by the following:

$$A = 0.5dT$$

where

- A = required reinforcement, mm² (in²)
 d = diameter of the finished opening in the given plane, mm (in.)
 T = minimum required thickness of plate, exclusive of corrosion allowance, as determined from 4-4-1A1/5.7; mm (in.)

As an alternative, the thickness of flat heads may be increased to provide the necessary reinforcement by using $2K$ in Equations 4 and 6 given in 4-4-1A1/5.7.3. However, the value of $2K$ to be used in the equations need not exceed 0.75. For the types of construction indicated in 4-4-1A1/Figures 7j and 7k, the quantity under the square-root of Equations 5 and 7 given in 4-4-1A1/5.7.3 is to be doubled.

Flat heads that have an opening with a diameter that exceeds one-half of the head diameter, or shortest span, are to be designed as a flange in accordance with bolted flange-connection practice.

7.5 Reinforcement Limits

Metal in the vessel and nozzle walls, exclusive of corrosion allowance, over and above the thickness required to resist pressure may be considered as reinforcement within the reinforcement limits as specified below.

7.5.1 Limits Along Wall

The limits of reinforcement measured along the vessel wall are to be at a distance on each side of the axis of the opening (or nozzle) equal to the greater of the following requirements:

- i) The diameter of the finished opening.
- ii) The radius of the finished opening plus the thickness of the vessel wall, plus the thickness of the nozzle wall

7.5.2 Limits Normal to Wall

The limits of reinforcement measured normal to the pressure vessel wall are to be parallel to the contour of the vessel surface and at a distance from each surface equal to the smaller of the following requirements:

- i) 2.5 times the shell thickness
- ii) 2.5 times the nozzle wall thickness, plus the thickness of any added reinforcement exclusive of the weld metal on the side of the shell under consideration

7.7 Metal Having Reinforcement Value

7.7.1 Reinforcement Available in Vessel Wall

Metal in the vessel wall, exclusive of corrosion allowance, over and above the thickness required to resist pressure may be considered as reinforcement within the reinforcement limits given in 4-4-1A1/7.5. The cross-sectional area of the vessel wall available as reinforcement is the larger of the A_1 values given by the following equations.

$$A_1 = (ET - FT_r)d$$

$$A_1 = 2(ET - FT_r)(T + T_n)$$

where

- A_1 = area in the excess thickness in the vessel wall available for reinforcement; mm² (in²)
- E = weld joint efficiency, to be taken as:
- The longitudinal weld joint efficiency when any part of the opening passes through a longitudinal weld joint; or
 - 1.0 when the opening is made in the seamless plate or when the opening passes through a circumferential joint in a shell (exclusive of head to shell joints)
- T = thickness of the vessel wall, less corrosion allowance; mm (in.)
- F = a factor, as defined in 4-4-1A1/7.3.1
- T_r = the minimum required thickness of a seamless shell or head as defined in 4-4-1A1/7.3.1
- T_n = thickness of the nozzle wall, exclusive of corrosion allowance; mm (in.)
- d = diameter of the finished opening (or internal diameter of the nozzle) less corrosion allowance, in the plane under consideration; mm (in.)

7.7.2 Reinforcement Available in Nozzles

7.7.2(a) *Nozzles extending outside the vessel.* The nozzle wall, exclusive of corrosion allowance, over and above the thickness required to resist pressure, and in that part of the nozzle extending outside the pressure vessel wall, may be considered as reinforcement within the reinforcement limits given in 4-4-1A1/7.5. The maximum area on the nozzle wall available as reinforcement is the smaller of the values of A_2 given by the following equations.

$$A_2 = (T_n - T_m)5T$$

$$A_2 = (T_n - T_m)(5T_n + 2T_e)$$

where

- A_2 = area of excess thickness in the nozzle wall available for reinforcement; mm² (in²)
- T_m = the minimum required thickness of a seamless nozzle wall, excluding corrosion allowance, found by the equation used for T_r for shell; mm (in.)
- T_e = thickness of reinforcing element; mm (in.)
- T = thickness of vessel wall, less corrosion allowance; mm (in.)
- T_n = thickness of nozzle wall, exclusive of the corrosion allowance; mm (in.); which is not to be less than the smallest of the following:
- The minimum required thickness of the seamless shell or head;
 - Thickness of standard-wall pipe; or
 - The minimum required thickness of a pipe based on 41.4 bar (42.2 kgf/cm², 600 psi) internal pressure.

7.7.2(b) *Nozzles extending inside the vessel.* All metal exclusive of corrosion allowance in the nozzle wall extending inside the pressure vessel and within the reinforcement limits specified in 4-4-1A1/7.5 may be included as reinforcement.

7.7.3 Added Reinforcement

Metal added as reinforcement and metal in attachment welds, provided they are within the reinforcement limits, may be included as reinforcement.

7.9 Strength of Reinforcement

7.9.1 Material Strength

In general, material used for reinforcement is to have an allowable stress value equal to or greater than that of the material in the vessel wall. Where material of lower strength is used, the area available for reinforcement is to be proportionally reduced by the ratio of the allowable stresses. No credit, however, is to be taken for the additional strength of any reinforcement having a higher allowable stress than the vessel wall. Deposited weld metal used as reinforcement is to be assumed to have an allowable stress value equal to the weaker of the materials connected by the weld.

7.9.2 Required Strength of Nozzle Attachment Weld

In the plane normal to the vessel wall and passing through the center of the opening, the strength of the weld attaching the nozzle and reinforcement element to the vessel wall is to be at least equal to the smallest of the following:

$$V = dT_r S$$

$$V = [d_u T_r - (2d - d_u)(T - T_r) + A_s] S$$

$$V = [d_u T_r - 2T(T - T_r) + A_s] S$$

where

V = the required strength (through load-carrying paths; see e.g., 4-4-1A1/Figure 10) to be provided by weldment or by the combination of weldment and nozzle wall to resist shear from pressure loading; N (kgf, lbf)

d_u = diameter of the unfinished opening prior to nozzle installation; mm (in.)

A_s = total stud hole cross-section area where stud holes are tapped into the vessel wall; mm² (in²)

S = allowable stress of the vessel wall material from 4-4-1A1/Table 2; N/mm² (kgf/mm², psi)

d , T_r , T are as defined in 4-4-1A1/7.7.1.

7.9.3 Calculating the Strength of Attachment Weld

Sufficient welding is to be deposited to develop the strength (through load-carrying paths, see 4-4-1A1/Figure 10) of the reinforcing parts through shear or tension in the weld and nozzle wall, as applicable. The combined strength of the weld or nozzle wall or both, as applicable, is to be computed and is not to be less than the value of V specified in 4-4-1A1/7.9.2. The weld shear areas to be used in the computation are to be in accordance with the following provisions:

- i) The strength of the groove welds is to be based on half of the area subjected to shear, as applicable, computed using the minimum weld depth dimension at the line of load-carrying path in the direction under consideration. The diameter of the weld is to be taken as the inside diameter of the weld when calculating path number three (see 4-4-1A1/Figure 10), or the mean diameter of the weld when calculating path number one or two (see 4-4-1A1/Figure 10).
- ii) The strength of the fillet weld is to be based on half of the area subject to shear, computed on the inside diameter of the weld when calculating path number 3, or the mean diameter of the weld when calculating path number one or two, using weld leg dimension in the direction under consideration.

The allowable stress values for groove and fillet welds and for shear in nozzle necks, in percentages of stress value for the vessel material, are as follows:

Nozzle wall shear	70%
Groove weld tension	74%
Groove weld shear	60%
Fillet weld shear	49%

FIGURE 10
Load-carrying Paths in Welded Nozzle Attachments

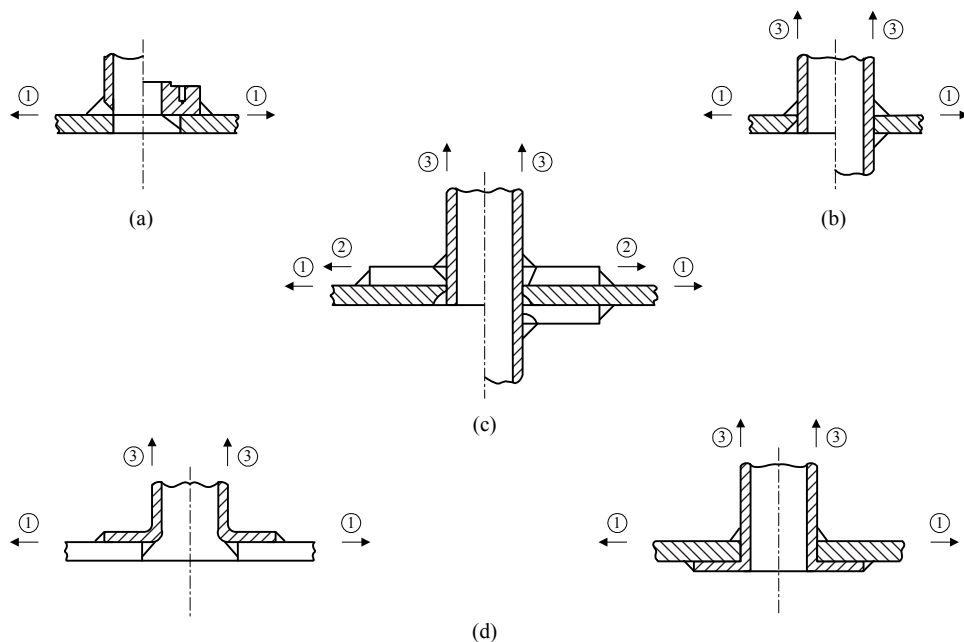

- ① Denotes the load-carrying path acting perpendicular to the nozzle centerline about the nozzle at the face of the vessel.
- ② Denotes the load-carrying path acting perpendicular to the nozzle centerline about the nozzle at the face of the external pad.
- ③ Denotes the load-carrying path about the nozzle acting parallel to the nozzle centerline.

7.11 Reinforcement of Multiple Openings

7.11.1 Spacing of Openings

Two adjacent openings are to have a distance between centers not less than $1\frac{1}{3}$ times their average diameter.

7.11.2 Reinforcement Overlapping

When adjacent openings are so spaced that their limits of reinforcement overlap, the opening is to be reinforced in accordance with 4-4-1A1/7.3 with a reinforcement that has an area equal to the combined area of the reinforcement required for the separate openings. No portion of the cross section is to be considered as applying to more than one opening or be evaluated more than once in a combined area.

7.11.3 Reinforcement of Holes Arranged in a Definite Pattern

When a shell has a series of holes in a definite pattern, the net cross-sectional area between any two finished openings within the limits of the actual shell wall, excluding the portion of reinforcing part not fused to the shell wall, is to equal at least $0.7F$ of the cross-sectional area obtained by multiplying the center-to-center distance of the openings by T_p , the required thickness of a seamless shell, where the factor F is taken from 4-4-1A1/Figure 9 for the plane under consideration. See illustration of these requirements in 4-4-1A1/Figure 11.

FIGURE 11
Illustration of Rules Given in 4-4-1A1/7.11.3

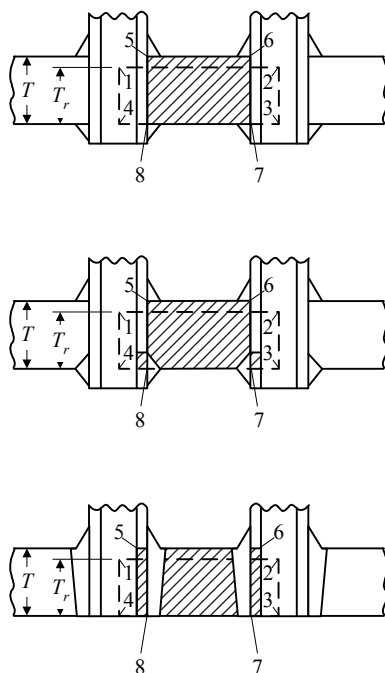

The cross-section area represented by 5, 6, 7, 8, shall be at least equal to the area of the rectangle represented by 1, 2, 3, 4 multiplied by 0.7F, in which F is a value from 4-4-1A1/Figure 9 and T_r is the required thickness of a seamless shell

9 Boiler Tubes

9.1 Materials

Tubes for water-tube boilers, superheaters and other parts of a boiler, where subjected to internal pressure, are to be of seamless steel or electric-resistance-welded tubing.

9.3 Maximum Allowable Working Pressure

The maximum allowable working pressure and the minimum required thickness are to be in accordance with the following equations:

$$W = fS \left[\frac{2T - 0.01D - 2e}{D - (T - 0.005D - e)} \right]$$

$$T = \frac{WD}{2fS + W} + 0.005D + e$$

where

- D = outside diameter of tube; mm (in.)
- T = minimum thickness of tube wall; mm (in.)
- W = maximum working pressure; bar (kgf/cm², psi)

- S = maximum allowable working stress; N/mm² (kgf/mm², psi); at not less than the maximum expected mean wall temperature, m , of the tube wall, which in no case is to be taken as less than 371°C (700°F) for tubes absorbing heat. For tubes which do not absorb heat, the wall temperature may be taken as the temperature of the fluid within the tube, but not less than the saturation temperature. Appropriate values of S are to be taken from 4-4-1A1/Table 2.
- m = sum of outside and inside surface temperatures divided by 2
- e = 1 mm (0.04 in.) over a length at least equal to the length of the seat plus 25 mm (1 in.) for tubes expanded into tube seats, see 4-4-1A1/9.5.
- = 0 for tubes strength-welded to headers and drums
- f = factor for units of measure, 10 (100, 1) for SI (MKS, US) units, respectively.

9.5 Tube-end Thickness

The thickness of the ends of tubes strength-welded to headers or drums need not be made greater than the run of tube as determined from 4-4-1A1/9.3. However, the thickness of tubes, where expanded into headers or drums, is to be no less than the minimum thickness required by 4-4-1A1/9.3 for each diameter for which a working pressure is tabulated. The minimum thickness of tubes or nipples for expanding into tube seats may be calculated from 4-4-1A1/9.3 with e equal to zero, provided the thickness at the end of the tubes to be expanded is made a minimum of:

- i) 2.40 mm (0.095 in.) for tubes 32 mm (1.25 in.) outside diameter.
- ii) 2.67 mm (0.105 in.) for tubes more than 32 mm (1.25 in.) outside diameter and up to 51 mm (2 in.) outside diameter inclusive.
- iii) 3.05 mm (0.120 in.) for tubes more than 51 mm (2 in.) outside diameter and up to 76 mm (3 in.) outside diameter inclusive.
- iv) 3.43 mm (0.135 in.) for tubes more than 76 mm (3 in.) outside diameter and up to 102 mm (4 in.) outside diameter inclusive.
- v) 3.81 mm (0.150 in.) for tubes more than 102 mm (4 in.) outside diameter and up to 127 mm (5 in.) outside diameter inclusive.

9.7 Tube-end Projection

The ends of all tubes and nipples used in water-tube boilers are to project through the tube plate or header, not less than 6.4 mm (0.25 in.) nor more than 19 mm (0.75 in.). They are to be expanded in the plate and then either bell-mouthed or beaded. Where tubes are to be attached to tube sheets by means of welding, details are to be submitted for approval.

11 Joint Designs

Welded joints are to be designed in accordance with 2-4-2/7 and 2-4-2/9.

13 Joint and Dimensional Tolerances

Joint and dimensional tolerances are to be in accordance with 2-4-2/5.

15 Weld Tests

Welding procedure and welder/welding operator qualification tests are to be in accordance with Section 2-4-3.

17 Radiography and Other Nondestructive Examination

Radiography of butt-welded seams is to be in accordance with 2-4-2/23.

19 Preheat and Postweld Heat Treatment

Preheat and postweld heat treatments are to be in accordance with 2-4-2/11 through 2-4-2/21.

21 Hydrostatic Tests

21.1 Boilers

All completed boilers (after all required nondestructive examination and after postweld heat treatment) are to be subjected to a hydrostatic test at not less than 1.5 times the design pressure or the maximum allowable pressure (the pressure to be stamped on the nameplate is to be used) in the presence of a Surveyor. The pressure gauge used in the test is to have a maximum scale of about twice the test pressure, but in no case is the maximum scale to be less than 1.5 times the test pressure. Following the hydrostatic test, the test pressure may be reduced to the design or the maximum allowable working pressure, and an inspection is to be made by the Surveyor of all joints and connections.

21.3 Pressure Vessels

All completed pressure vessels (after all required non-destructive examination and after postweld heat treatment) are to be subjected to a hydrostatic test at not less than 1.3 times the design pressure or the maximum allowable pressure (the pressure to be stamped on the nameplate is to be used) in the presence of a Surveyor. The pressure gauge used in the test is to have a maximum scale of about twice the test pressure, but in no case is the maximum scale to be less than 1.3 times the test pressure. Following the hydrostatic test, the test pressure may be reduced to the design or the maximum allowable working pressure, and an inspection is to be made by the Surveyor of all joints and connections. Where hydrostatic tests are impracticable, alternative methods of pressure tests, such as a pneumatic pressure test, may be considered for pressure vessels, subject to such test procedures being submitted for consideration in each case.

TABLE 1
Joint Efficiencies for Welded Joints

Type of Joint	Limitation	Degree of Radiography		
		(a) Full ⁽¹⁾	(b) Spot ⁽¹⁾	(c) None ⁽²⁾
(a) Butt joints as attained by double welding or by other means which will obtain the same quality of deposited weld metal on the inside and outside weld surfaces. Welds using metal backing strips which remain in place are excluded	None	1.00	0.85 ⁽⁴⁾	0.70
(b) Single welded butt joint with backing strip other than those included above	None, except 15.9 mm (0.625 in.) maximum thickness in circumferential butt welds having one plate offset as shown in 2-4-2/Figure 1.	0.90	0.80	0.65
(c) Single-welded butt joint without use of backing strip	Circumferential joints only, not over 15.9 mm (0.625 in.) thick and not over 610 mm (24 in.) outside diameter.			0.60
(d) Double full-fillet lap joint	Longitudinal joints not over 9.5 mm (0.375 in.) thick. Circumferential joints not over 15.9 mm (0.625 in.) thick.			0.55
(e) Single full-fillet lap joints with plug welds	Circumferential joints for attachment of heads, not over 610 mm (24 in.) outside diameter to shell not over 12.7 mm (0.5 in.) thick ⁽³⁾ .			0.50
(f) Single full-fillet lap joints without plug welds	<p>i) For the attachment of heads convex to pressure to shell not over 15.9 mm (0.625 in.) required thickness, only with use of fillet weld on the inside of shell. Or</p> <p>ii) For attachment of heads having pressure on either side to shells not over 610 mm (24 in.) inside diameter and not over 6.4 mm (0.25 in.) required thickness with fillet weld on outside of head flange only.</p>			0.45

Notes

- 1 Full and spot radiograph requirements covered in 2-4-2/23.
- 2 The maximum allowable joint efficiencies shown in this column are the weld-joint efficiencies multiplied by 0.8 (and rounded off to the nearest 0.05) to effect the basic reduction in allowable stress required by the Rules for welded vessels that are not spot examined. This value may only be used provided that a maximum allowable unit working stress not exceeding 0.8 of the appropriate *S* value in 4-4-1A1/Table 2 is used in all other design calculations except for stress *S* for unstayed flat heads and covers in 4-4-1A1/5.7, and stresses used in flange designs.
- 3 Joints attaching hemispherical heads to shells are excluded.
- 4 Seamless vessel sections and heads with circumferential butt joints, excluding hemispherical heads, that are spot radiographed are to be designed for circumferential stress using the appropriate *S* value in 4-4-1A1/Table 2. Where seamless vessel sections and heads with circumferential butt joints are not spot radiographed, they are to be designed for circumferential stress using stress value not to exceed 0.85 of the appropriate *S* value in 4-4-1A1/Table 2. This stress reduction is not applicable to *T_r* and *T_m* in reinforcement calculations.

**TABLE 2 (SI units)
Maximum Allowable Stress Values for Ferrous Materials – N/mm²**

Stress values shown in italics are permissible, but use of these materials at these temperatures is not current practice.

The stress values in this table may be interpolated to determine values for intermediate temperatures.

Stress values for other materials may be the same as given in the ASME Boiler and Pressure Vessel Code.

ABS Gr.	ASTM Gr.	Nominal Comp.	Min. Tensile strength	Note	Metal temperature (°C) not exceeding															
					-29 to 149	204	260	316	343	371	399	427	454	482	510	538	566	593	621	649
Plate steels – Section 2-3-2																				
MA	A285 Gr.A	C	310	1,4	88.9	88.9	88.9	84.8	82.0	79.3	73.8	57.2	45.5	34.5						
MB	A285 Gr.B	C	345	1,4	98.6	98.6	95.1	91.7	86.2	75.8	64.8	50.3	34.5							
MC	A285 Gr.C	C	379	1,4	108.2	108.2	105.5	102.0	98.6	89.6	74.5	60.0	40.7							
MD	A515 Gr.55	C Si	379	1	108.2	108.2	105.5	102.0	98.6	89.6	74.5	60.0	40.7	27.6	17.2					
ME	A515 Gr.60	C	414	1	117.9	117.9	113.1	108.9	105.5	89.6	74.5	60.0	40.7	27.6	17.2					
MF	A515 Gr.65	C	448	1	128.2	128.2	123.4	119.3	115.1	95.8	78.6	60.0	40.7	27.6	17.2					
MG	A515 Gr.70	C	483	1	137.9	137.9	133.8	129.6	124.8	102.0	82.7	64.1	46.2	27.6	17.2					
H	A204 Gr.A	C-1/2 Mo	448	2	128.2	128.2	128.2	128.2	128.2	128.2	126.9	123.4	94.5	56.5	33.1					
I	A204 Gr.B	C-1/2 Mo	483	2	137.9	137.9	137.9	137.9	137.9	137.9	137.9	137.2	133.1	94.5	56.5	33.1				
J	A204 Gr. C	C-1/2 Mo	517	2	147.5	147.5	147.5	147.5	147.5	147.5	147.5	142.7	95.5	56.5	33.1					
K	A516 Gr.55	C	379	1	108.2	108.2	105.5	102.0	98.6	89.6	74.5	60.0	40.7	27.6	17.2					
L	A516 Gr. 60	C	414	1	117.9	117.9	113.1	108.9	105.5	89.6	74.5	60.0	40.7	27.6	17.2					
M	A516 Gr. 65	C	448	1	128.2	128.2	123.4	119.3	115.1	95.8	78.6	60.0	40.7	27.6	17.2					
N	A516 Gr. 70	C	483	1	137.9	137.9	133.8	129.6	124.8	102.0	82.7	64.1	46.2	27.6	17.2					
Forged steel drum – Section 2-3-3																				
A	A266 Cl-1		414	1	117.9	117.9	112.4	105.5	102.0	98.6	89.6	74.5	60.0	40.7	27.6	17.2				
B	A266 Cl-2		483	1	137.9	137.9	135.1	126.9	122.7	118.6	102.0	82.7	64.1	46.2	27.6	17.2				
Castings – Sections 2-3-9 and 2-3-10																				
3	A216.WCA	C	414	1,7	117.9	117.9	112.4	105.5	102.0	98.6	89.6	74.5	60.0	40.7	27.6	17.2				
4	A216 WCB	C	483	1,7	137.9	137.9	135.1	126.9	122.7	118.6	102.0	82.7	64.1	46.2	27.6	17.2				
60-40-18	A395	Nodular iron	414	7	82.7															
Tubes – Section 2-3-5																				
D	A178 Gr.A	C-Mn	324	1,3,5,6	92.4	92.4	92.4	91.7	88.3	85.5	73.8	62.1	49.0	34.5	17.9	9.0				
F	A178 Gr.C	C-Mn	414	1,3,5	117.9	117.9	117.9	117.9	117.9	107.6	89.6	74.5	60.0	34.5	23.4	14.5				
G	A226	C-Mn	324	1,5,6	92.4	92.4	92.4	91.7	88.3	85.5	73.8	62.1	49.0	34.5	20.7	10.3				
H	A192	C-Mn	324	1,6	92.4	92.4	92.4	91.7	88.3	85.5	73.8	62.1	49.0	34.5	31.0	17.2				
J	A210 Gr.A-1	C-Mn	414	1	117.9	117.9	117.9	117.9	117.9	107.6	89.6	74.5	60.0	40.7	27.6	17.2				
K	A209 Gr.T1	C-Mn-1/2 Mo	379	2	108.2	108.2	108.2	108.2	108.2	106.2	102.7	100.0	94.5	56.5	33.1					
L	A209 Gr.T1a	C-Mn-1/2 Mo	414	2	117.9	117.9	117.9	117.9	117.9	115.8	113.1	109.6	106.2	94.5	56.5	33.1				
M	A209 Gr.T1b	C-Mn-1/2 Mo	365	2	104.1	104.1	104.1	104.1	103.4	101.4	98.6	96.5	93.1	89.6	56.5	33.1				
N	A213 Gr.T11	1-1/4 Cr - 1/2 Mo	414		117.9	115.8	111.7	108.2	106.2	104.1	102.0	99.3	96.5	93.8	64.1	43.4	29.0	19.3	13.1	8.3
O	A213 Gr.T12	1 Cr - 1/2 Mo	414		113.8	113.8	113.8	112.4	110.3	108.9	106.9	105.5	102.7	100.0	77.9	49.6	31.0	19.3	12.4	7.6
P	A213 Gr.T22	2-1/4 Cr - 1 Mo	414		114.5	114.5	114.5	114.5	114.5	114.5	114.5	114.5	114.5	93.8	74.5	55.2	39.3	26.2	16.5	9.7

Notes

- 1 Upon prolonged exposure to temperatures above 425°C, the carbide phase of carbon steel may be converted to graphite.
- 2 Upon exposure to temperatures above about 470°C, the carbide phase of carbon-molybdenum steel may be converted to graphite.
- 3 Only killed steel is to be used above 482°C.
- 4 Flange quality in this specification not permitted above 454°C.
- 5 Above 371°C these stress values include a joint efficiency factor of 0.85. When material to this specification is used for pipe, multiply the stress values up to and including 371°C by a factor of 0.85.
- 6 Tensile value is expected minimum.
- 7 To these values a quality factor of 0.80 is to be applied unless nondestructive testing (NDT) is carried out beyond that required by material specification. See UG 24 of ASME Code, Section VIII, Division 1.

TABLE 2 (MKS units)
Maximum Allowable Stress Values for Ferrous Materials – kgf/mm²

Stress values shown in italics are permissible, but use of these materials at these temperatures is not current practice.

The stress values in this table may be interpolated to determine values for intermediate temperatures.

Stress values for other materials may be the same as given in the ASME Boiler and Pressure Vessel Code.

ABS Gr.	ASTM Gr.	Nominal Comp.	Min. Tensile strength	Note	Metal temperature (°C) not exceeding															
					-29 to 149	204	260	316	343	371	399	427	454	482	510	538	566	593	621	649
Plate steels – Section 2-3-2																				
MA	A285 Gr.A	C	31.6	1,4	9.07	9.07	9.07	8.65	8.37	8.09	7.52	5.84	4.64	3.52						
MB	A285 Gr.B	C	35.2	1,4	10.05	10.05	10.05	9.70	9.35	8.79	7.73	6.61	5.13	3.52						
MC	A285 Gr.C	C	38.7	1,4	11.04	11.04	11.04	10.76	10.41	10.05	9.14	7.59	6.12	4.15						
MD	A515 Gr.55	C Si	38.7	1	11.04	11.04	11.04	10.76	10.41	10.05	9.14	7.59	6.12	4.15	2.81	1.76				
ME	A515 Gr.60	C	42.2	1	12.02	12.02	12.02	11.53	11.11	10.76	9.14	7.59	6.12	4.15	2.81	1.76				
MF	A515 Gr.65	C	45.7	1	13.08	13.08	13.08	12.58	12.16	11.74	9.77	8.01	6.12	4.15	2.81	1.76				
MG	A515 Gr.70	C	49.2	1	14.06	14.06	14.06	13.64	13.22	12.73	10.41	8.44	6.54	4.71	2.81	1.76				
H	A204 Gr.A	C-1/2 Mo	45.7	2	13.08	13.08	13.08	13.08	13.08	13.08	13.08	12.94	12.59	9.63	5.77	3.37				
I	A204 Gr.B	C-1/2 Mo	49.2	2	14.06	14.06	14.06	14.06	14.06	14.06	14.06	13.99	13.57	9.63	5.77	3.37				
J	A204 Gr. C	C-1/2 Mo	52.7	2	15.05	15.05	15.05	15.05	15.05	15.05	15.05	15.05	14.55	9.36	5.77	2.27				
K	A516 Gr.55	C	38.7	1	11.04	11.04	11.04	10.76	10.41	10.05	9.14	7.59	6.12	4.15	2.81	1.76				
L	A516 Gr. 60	C	42.2	1	12.02	12.02	12.02	11.53	11.11	10.76	9.14	7.59	6.12	4.15	2.81	1.76				
M	A516 Gr. 65	C	45.7	1	13.08	13.08	13.08	12.58	12.16	11.74	9.77	8.01	6.12	4.15	2.81	1.76				
N	A516 Gr. 70	C	49.2	1	14.06	14.06	14.06	13.64	13.22	12.73	10.41	8.44	6.54	4.71	2.81	1.76				
Forged steel drum – Section 2-3-3																				
A	A266 Cl-1		42.2	1	12.02	12.02	11.46	10.76	10.41	10.05	9.14	7.59	6.12	4.15	2.81	1.76				
B	A266 Cl-2		49.2	1	14.06	14.06	13.78	12.94	12.51	12.09	10.41	8.44	6.54	4.71	2.81	1.76				
Castings – Sections 2-3-9 and 2-3-10																				
3	A216.WCA	C	42.2	1,7	12.02	12.02	11.46	10.76	10.41	10.05	9.14	7.59	6.12	4.15	2.81	1.76				
4	A216 WCB	C	49.2	1,7	14.06	14.06	13.78	12.94	12.51	12.09	10.41	8.44	6.54	4.71	2.81	1.76				
60-40-18	A395	Nodular iron	42.2	7	8.44															
Tubes – Section 2-3-5																				
D	A178 Gr.A	C-Mn	33.0	1,3,5,6	9.42	9.42	9.42	9.35	9.00	8.72	7.52	6.34	4.99	3.52	1.83	0.91				
F	A178 Gr.C	C-Mn	42.2	1,3,5	12.02	12.02	12.02	12.02	12.02	10.96	9.14	7.59	6.12	3.52	2.39	1.48				
G	A226	C-Mn	33.0	1,5,6	9.42	9.42	9.42	9.35	9.00	8.72	7.52	6.33	4.99	3.52	2.11	1.05				
H	A192	C-Mn	33.0	1,6	9.42	9.42	9.42	9.35	9.00	8.72	7.52	6.33	4.99	3.52	3.16	1.76				
J	A210 Gr.A-1	C-Mn	42.2	1	12.02	12.02	12.02	12.02	12.02	10.97	9.14	7.59	6.12	4.15	2.81	1.76				
K	A209 Gr.T1	C-Mn-1/2 Mo	38.7	2	11.04	11.04	11.04	11.04	11.04	11.04	10.83	10.46	10.19	9.63	5.77	3.37				
L	A209 Gr.T1a	C-Mn-1/2 Mo	42.2	2	12.02	12.02	12.02	12.02	12.02	11.81	11.53	11.18	10.83	9.63	5.77	3.37				
M	A209 Gr.T1b	C-Mn-1/2 Mo	37.3	2	10.62	10.62	10.62	10.62	10.55	10.36	10.05	9.84	9.49	9.14	5.77	3.37				
N	A213 Gr.T11	1-1/4 Cr - 1/2 Mo	42.2		12.02	11.81	11.39	11.04	10.83	10.62	10.41	10.12	9.84	9.56	6.54	4.43	2.95	1.97	1.34	0.84
O	A213 Gr.T12	1 Cr - 1/2 Mo	42.2		11.60	11.60	11.60	11.46	11.25	11.11	10.90	10.76	10.48	10.19	7.94	5.06	3.16	1.97	1.27	0.77
P	A213 Gr.T22	2-1/4 Cr - 1 Mo	42.2		11.67	11.67	11.67	11.67	11.67	11.67	11.67	11.67	11.67	9.56	7.59	5.62	4.00	2.67	1.69	0.98

Notes

- 1 Upon prolonged exposure to temperatures above 425°C, the carbide phase of carbon steel may be converted to graphite.
- 2 Upon exposure to temperatures above about 470°C, the carbide phase of carbon-molybdenum steel may be converted to graphite.
- 3 Only killed steel is to be used above 482°C.
- 4 Flange quality in this specification not permitted above 454°C.
- 5 Above 371°C these stress values include a joint efficiency factor of 0.85. When material to this specification is used for pipe, multiply the stress values up to and including 371°C by a factor of 0.85.
- 6 Tensile value is expected minimum.
- 7 To these values a quality factor of 0.80 is to be applied unless nondestructive testing (NDT) is carried out beyond that required by material specification. See UG 24 of ASME Code, Section VIII, Division 1.

TABLE 2 (US units)
Maximum Allowable Stress Values for Ferrous Materials – ksi

Stress values shown in italics are permissible, but use of these materials at these temperatures is not current practice.

The stress values in this table may be interpolated to determine values for intermediate temperatures.

Stress values for other materials may be the same as given in the ASME Boiler and Pressure Vessel Code.

ABS Gr.	ASTM Gr.	Nominal Comp.	Min. Tensile strength	Note	Metal temperature (°F) not exceeding															
					-20 to 300	400	500	600	650	700	750	800	850	900	950	1000	1050	1100	1150	1200
Plate steels – Section 2-3-2																				
MA	A285 Gr.A	C	45	1,4	12,9	12,9	12,9	12,3	11,9	11,5	<i>10,7</i>	<i>8,3</i>	<i>6,6</i>	<i>5,0</i>						
MB	A285 Gr.B	C	50	1,4	14,3	14,3	14,3	13,8	13,3	12,5	<i>11,0</i>	<i>9,4</i>	<i>7,3</i>	<i>5,0</i>						
MC	A285 Gr.C	C	55	1,4	15,7	15,7	15,3	14,8	14,3	13,0	<i>10,8</i>	<i>8,7</i>	<i>5,9</i>							
MD	A515 Gr.55	C Si	55	1	15,7	15,7	15,3	14,8	14,3	13,0	<i>10,8</i>	<i>8,7</i>	<i>5,9</i>	<i>4,0</i>	<i>2,5</i>					
ME	A515 Gr.60	C	60	1	17,1	17,1	16,4	15,8	15,3	13,0	<i>10,8</i>	<i>8,7</i>	<i>5,9</i>	<i>4,0</i>	<i>2,5</i>					
MF	A515 Gr.65	C	65	1	18,6	18,6	17,9	17,3	16,7	13,9	<i>11,4</i>	<i>8,7</i>	<i>5,9</i>	<i>4,0</i>	<i>2,5</i>					
MG	A515 Gr.70	C	70	1	20,0	20,0	19,4	18,8	18,1	14,8	<i>12,0</i>	<i>9,3</i>	<i>6,7</i>	<i>4,0</i>	<i>2,5</i>					
H	A204 Gr.A	C-1/2 Mo	65	2	18,6	18,6	18,6	18,6	18,6	18,6	18,4	17,9	13,7	8,2	4,8					
I	A204 Gr.B	C-1/2 Mo	70	2	20,0	20,0	20,0	20,0	20,0	20,0	19,9	19,3	13,7	8,2	4,8					
J	A204 Gr. C	C-1/2 Mo	75	2	21,4	21,4	21,4	21,4	21,4	21,4	21,4	20,7	13,7	8,2	4,8					
K	A516 Gr.55	C	55	1	15,7	15,7	15,3	14,8	14,3	13,0	<i>10,8</i>	<i>8,7</i>	<i>5,9</i>	<i>4,0</i>	<i>2,5</i>					
L	A516 Gr. 60	C	60	1	17,1	17,1	16,4	15,8	15,3	13,0	<i>10,8</i>	<i>8,7</i>	<i>5,9</i>	<i>4,0</i>	<i>2,5</i>					
M	A516 Gr. 65	C	65	1	18,6	18,6	17,9	17,3	16,7	13,9	<i>11,4</i>	<i>8,7</i>	<i>5,9</i>	<i>4,0</i>	<i>2,5</i>					
N	A516 Gr. 70	C	70	1	20,0	20,0	19,4	18,8	18,1	14,8	<i>12,0</i>	<i>9,3</i>	<i>6,7</i>	<i>4,0</i>	<i>2,5</i>					
Forged steel drum – Section 2-3-3																				
A	A266 Cl-1		60	1	17,1	17,1	16,3	15,3	14,8	14,3	13,0	<i>10,8</i>	<i>8,7</i>	<i>5,9</i>	<i>4,0</i>	<i>2,5</i>				
B	A266 Cl-2		70	1	20,0	20,0	19,6	18,4	17,8	17,2	14,8	<i>12,0</i>	<i>9,3</i>	<i>6,7</i>	<i>4,0</i>	<i>2,5</i>				
Castings – Sections 2-3-9 and 2-3-10																				
3	A216.WCA	C	60	1,7	17,1	17,1	16,3	15,3	14,8	14,3	13,0	<i>10,8</i>	<i>8,7</i>	<i>5,9</i>	<i>4,0</i>	<i>2,5</i>				
4	A216 WCB	C	70	1,7	20,0	20,0	19,6	18,4	17,8	17,2	14,8	<i>12,0</i>	<i>9,3</i>	<i>6,7</i>	<i>4,0</i>	<i>2,5</i>				
60-40-18	A395	Nodular iron	60	7	12,0															
Tubes – Section 2-3-5																				
D	A178 Gr.A	C-Mn	47	1,3,5,6	13,4	13,4	13,4	13,3	12,8	12,4	10,7	9,0	7,1	5,0	2,6	1,3				
F	A178 Gr.C	C-Mn	60	1,3,5	17,1	17,1	17,1	17,1	17,1	15,6	13,0	10,8	8,7	5,0	3,4	2,1				
G	A226	C-Mn	47	1,5,6	13,4	13,4	13,4	13,3	12,8	12,4	10,7	9,0	7,1	5,0	3,0	1,5				
H	A192	C-Mn	47	1,6	13,4	13,4	13,4	13,3	12,8	12,4	10,7	9,0	7,1	5,0	4,5	2,5				
J	A210 Gr.A-1	C-Mn	60	1	17,1	17,1	17,1	17,1	17,1	15,6	13,0	10,8	8,7	5,9	4,0	2,5				
K	A209 Gr.T1	C-Mn-1/2 Mo	55	2	15,7	15,7	15,7	15,7	15,7	15,7	15,4	14,9	14,5	13,7	8,2	4,8				
L	A209 Gr.T1a	C-Mn-1/2 Mo	60	2	17,1	17,1	17,1	17,1	17,1	16,8	16,4	15,9	15,4	13,7	8,2	4,8				
M	A209 Gr.T1b	C-Mn-1/2 Mo	53	2	15,1	15,1	15,1	15,1	15,0	14,7	14,3	14,0	13,5	13,0	8,2	4,8				
N	A213 Gr.T11	1-1/4 Cr - 1/2 Mo	60		17,1	16,8	16,2	15,7	15,4	15,1	14,8	14,4	14,0	13,6	9,3	6,3	4,2	2,8	1,9	1,2
O	A213 Gr.T12	1 Cr - 1/2 Mo	60		16,5	16,5	16,5	16,3	16,0	15,8	15,5	15,3	14,9	14,5	11,3	7,2	4,5	2,8	1,8	1,1
P	A213 Gr.T22	2-1/4 Cr - 1 Mo	60		16,6	16,6	16,6	16,6	16,6	16,6	16,6	16,6	16,6	13,6	10,8	8,0	5,7	3,8	2,4	1,4

Notes

- 1 Upon prolonged exposure to temperatures above 800°F, the carbide phase of carbon steel may be converted to graphite.
- 2 Upon exposure to temperatures above about 875°F, the carbide phase of carbon-molybdenum steel may be converted to graphite.
- 3 Only killed steel is to be used above 900°F.
- 4 Flange quality in this specification not permitted above 850°F.
- 5 Above 700°F these stress values include a joint efficiency factor of 0.85. When material to this specification is used for pipe, multiply the stress values up to and including 700°F by a factor of 0.85.
- 6 Tensile value is expected minimum.
- 7 To these values a quality factor of 0.80 is to be applied unless nondestructive testing (NDT) is carried out beyond that required by material specification. See UG 24 of ASME Code, Section VIII, Division 1.

CONTENTS

SECTION 1	Anchor Windlass	416
1	General	416
	1.1 Application	416
	1.3 Standards of Compliance	416
	1.5 Plans and Particulars to be Submitted	416
3	Materials and Fabrication	417
	3.1 Materials	417
	3.3 Welded Fabrication	417
5	Design	417
	5.1 Mechanical Design	417
	5.3 Hydraulic Systems	419
	5.5 Electrical Systems	419
	5.7 Protection of Mechanical Components	419
	5.9 Couplings	419
7	Shop Inspection and Testing	419
9	On-board Tests	420
11	Marking	420

PART

4

CHAPTER 5 Deck and Other Machinery

SECTION 1 Anchor Windlass

1 General

1.1 Application

The provisions of Part 4, Chapter 5, Section 1 (referred to as Section 4-5-1) apply to windlasses used for handling anchors and chains required by Part 3, Chapter 5.

1.3 Standards of Compliance

The design, construction and testing of windlasses are to conform to an acceptable standard or code of practice. To be considered acceptable, the standard or code of practice is to specify criteria for stresses, performance and testing.

The following are examples of standards presently recognized by ABS:

SNAME T & R Bulletin 3-15 - Guide to the Design and Testing of Anchor Windlasses for Merchant Ships

ISO 7825 Deck machinery general requirements

ISO 4568 Windlasses and anchor capstans Sea-going Vessels

JIS F6710 Steam Anchor Windlasses

JIS F6712 AC Electrical Anchor Windlasses

JIS F6713 Hydraulic Anchor Windlasses

JIS F6714 Windlasses

BS MA35 Specifications for Ship Deck Machinery Windlass

1.5 Plans and Particulars to be Submitted

The following plans showing the design specifications, the standard of compliance, engineering analyses and details of construction, as applicable, are to be submitted to ABS for evaluation:

- *(1 July 2018)* Windlass design specifications; anchor and chain cable particulars; **anchorage depth**; performance criteria; standard of compliance.
- Windlass arrangement plan showing all of the components of the anchoring/mooring system such as the prime mover, shafting, cable lifter, anchors and chain cables; mooring winches, wires and fairleads, if they form part of the windlass machinery; brakes; controls; etc.
- Dimensions, materials, welding details, as applicable, of all torque-transmitting (shafts, gears, clutches, couplings, coupling bolts, etc.) and all load bearing (shaft bearings, cable lifter, sheaves, drums, bed-frames, etc.) components of the windlass and of the winch, where applicable, including brakes, chain stopper (if fitted) and foundation.
- *(1 July 2018)* Hydraulic piping system diagram along with system design pressure, relief valves **arrangement and** setting, bill of materials, typical pipe joints, as applicable.

- Electric one line diagram along with cable specification and size; motor controller; protective device rating or setting; as applicable.
- Control, monitoring and instrumentation arrangements.
- Engineering analyses for torque-transmitting and load-bearing components demonstrating their compliance with recognized standards or codes of practice. Analyses for gears are to be in accordance with a recognized standard.
- Windlass foundation structure, including under deck supporting structures, and holding down arrangements.
- Plans and data for windlass electric motors including associated gears rated 100 kW (135 hp) and over.
- Calculations demonstrating that the windlass prime mover is capable of attaining the hoisting speed, the required continuous duty pull, and the overload capacity are to be submitted if the “load testing” including “overload” capacity of the entire windlass unit is not carried out at the shop [see 4-5-1/7ii].
- *(1 July 2018) Operation and maintenance procedures for the anchor windlass are to be incorporated in the vessel operations manual.*

3 Materials and Fabrication

3.1 Materials

Materials entered into the construction of torque-transmitting and load-bearing parts of windlasses are to comply with material specifications in Chapter 3 of the *ABS Rules for Materials and Welding (Part 2)* or of a national or international material standard. The proposed materials are to be indicated in the construction plans and are to be approved in connection with the design. All such materials are to be certified by the material manufacturers and are to be traceable to the manufacturers’ certificates.

3.3 Welded Fabrication

Weld joint designs are to be shown in the construction plans and are to be approved in association with the approval of the windlass design. Welding procedures and welders are to be qualified in accordance with Chapter 4 of the *ABS Rules for Materials and Welding (Part 2)*. Welding consumables are to be type-approved by ABS or are to be of a type acceptable to the Surveyor. The degree of nondestructive examination of welds and post-weld heat treatment, if any, are to be specified and submitted for consideration.

5 Design

Along with and notwithstanding the requirements of the chosen standard of compliance, the following requirements are also to be complied with. In lieu of conducting engineering analyses and submitting them for review, approval of the windlass mechanical design may be based on a type test, in which case the testing procedure is to be submitted for consideration. At the option of the manufacturers, windlass designs may be approved based on the Type Approval Program (see 1-1-A3/5 of the *ABS Rules for Conditions of Classification (Part 1)*).

5.1 Mechanical Design

5.1.1 Design Loads

5.1.1(a) Holding Loads. Calculations are to be made to show that, in the holding condition (single anchor, brake fully applied and chain cable lifter declutched), and under a load equal to 80% of the specified minimum breaking strength of the chain cable (see 2-2-2/Table 2 and 2-2-2/Table 3 of the *ABS Rules for Materials and Welding (Part 2)*), the maximum stress in each load bearing component will not exceed yield strength (or 0.2% proof stress) of the material. For installations fitted with a chain cable stopper, 45% of the specified minimum breaking strength of the chain cable may instead be used for the calculation.

5.1.1(b) Inertia Loads. The design of the drive train, including prime mover, reduction gears, bearings, clutches, shafts, wildcat and bolting is to consider the dynamic effects of sudden stopping and starting of the prime mover or chain cable so as to limit inertial load.

5.1.2 Continuous Duty Pull (1 July 2018)

The windlass prime mover is to be able to exert for at least 30 minutes a continuous duty pull (e.g., 30-minute short time rating as per 4-8-3/3.3.2 and 4-8-3/Table 4; or corresponding to S2-30 min. of IEC 60034-1), Z_{cont1} , corresponding to the grade (see 3-5-1/Table 1) and diameter, d , of the chain cables as follows:

Grade of chain	Z_{cont1}		
	N	kgf	lbf
1	$37.5d^2$	$3.82d^2$	$5425.7d^2$
2	$42.5d^2$	$4.33d^2$	$6149.1d^2$
3	$47.5d^2$	$4.84d^2$	$6872.5d^2$
Unit of d	mm	mm	in.

The values of the above table are applicable when using ordinary stockless anchors for anchorage depth down to 82.5 m (270 ft).

For anchorage depth deeper than 82.5 m (270 ft), a continuous duty pull Z_{cont2} is:

$$Z_{cont2} = Z_{cont1} + (D - 82.5) \times 0.27d^2 \text{ N}$$

$$Z_{cont2} = Z_{cont1} + (D - 82.5) \times 0.0275d^2 \text{ kgf}$$

$$Z_{cont2} = Z_{cont1} + (D - 270) \times 11.86d^2 \text{ lbf}$$

where D is the anchor depth, in meters (feet).

The value of Z_{cont} is based on the hoisting of one anchor at a time, and that the effects of buoyancy and hawse pipe efficiency (assumed to be 70%) have been accounted for. In general, stresses in each torque-transmitting component are not to exceed 40% of yield strength (or 0.2% proof stress) of the material under these loading conditions.

5.1.3 Overload Capability (1 July 2018)

The windlass prime mover is to be able to provide the necessary temporary overload capacity for breaking out the anchor. This temporary overload capacity or “short term pull” is to be at least 1.5 times the continuous duty pull applied for at least 2 minutes. The speed in this period may be lower than normal.

5.1.4 Hoisting Speed

The mean speed of the chain cable during hoisting of the anchor and cable is to be at least 9 m/min. For testing purposes, the speed is to be measured over two shots of chain cable and initially with at least three shots of chain (82.5 m or 45 fathoms in length) and the anchor submerged and hanging free.

5.1.5 Brake Capacity

The capacity of the windlass brake is to be sufficient to stop the anchor and chain cable when paying out the chain cable. Where a chain cable stopper is not fitted, the brake is to produce a torque capable of withstanding a pull equal to 80% of the specified minimum breaking strength of the chain cable without any permanent deformation of strength members and without brake slip. Where a chain cable stopper is fitted, 45% of the breaking strength may instead be applied.

5.1.6 Chain Cable Stopper

Chain cable stopper, if fitted, along with its attachments is to be designed to withstand, without any permanent deformation, 80% of the specified minimum breaking strength of the chain cable.

5.1.7 Support Structure

For vessels with length, L (as defined in 3-1-1/3.1) 80 meters and greater, the windlass supporting structures located on the exposed fore deck within the forward $0.25L$ are to meet the requirements in 3-5-1/11.3. Where the mooring winch is integral with the windlass, it is to be considered as a part of the windlass for the purpose of said paragraph.

5.3 Hydraulic Systems

Hydraulic systems where employed for driving windlasses are to comply with the provisions of 4-6-7/3.

5.5 Electrical Systems

5.5.1 Electric Motors

Electric motors are to meet the requirements of 4-8-3/3 and those rated 100 kW and over are to be certified by ABS. Motors installed in the weather are to have enclosures suitable for their location as provided for in 4-8-3/1.11. Where gears are fitted, they are to meet the requirements of Section 4-3-1 and those rated 100 kW (135 hp) and over are to be certified by ABS. The Surveyor's presence for material tests referred to in 4-3-1/3.1.2 and 4-3-1/3.3 is not required, subject to compliance with 4-5-1/3.1.

5.5.2 Electrical Circuits

Motor branch circuits are to be protected in accordance with the provisions of 4-8-2/9.17 and cable sizing is to be in accordance with 4-8-2/7.7.6. Electrical cables installed in locations subjected to the sea are to be provided with effective mechanical protection as provided for in 4-8-4/21.15.

5.7 Protection of Mechanical Components (1 July 2018)

To protect mechanical parts including component housings, a suitable protection system is to be fitted to limit the speed and torque at the prime mover. Consideration is to be given to a means to contain debris consequent to a severe damage of the prime mover due to overspeed in the event of uncontrolled rendering of the cable, particularly when an axial piston type hydraulic motor forms the prime mover.

5.9 Couplings (1 July 2018)

Windlasses are to be fitted with couplings which are capable of disengaging between the cable lifter and the drive shaft. Hydraulically or electrically operated couplings are to be capable of being disengaged manually.

7 Shop Inspection and Testing

Windlasses are to be inspected during fabrication at the manufacturers' facilities by a Surveyor for conformance with the approved plans. Acceptance tests, as specified in the specified standard of compliance, are to be witnessed by the Surveyor and include the following tests, as a minimum.

- i) *No-load test.* The windlass is to be run without load at nominal speed in each direction for a total of 30 minutes. If the windlass is provided with a gear change, additional run in each direction for 5 minutes at each gear change is required.
- ii) *Load test (1 July 2018).* The windlass is to be tested to verify that the continuous duty pull, overload capacity and hoisting speed as specified in 4-5-1/5.1 can be attained.

Where the required "load testing" including "overload" capacity of the entire windlass unit at the shop is not possible or practical, **these tests can be carried out on board ship. In these cases, functional testing in the manufacturer's works is to be performed under no-load conditions.** The manufacturer may submit powering calculations demonstrating that the windlass prime mover is capable of attaining the hoisting speed, the required continuous duty pull, and the overload capacity. These calculations are to be validated through testing of an anchor windlass unit. Once these calculations are validated, they may be used in place of the load tests within the scope of the calculations. Further, in addition to other testing requirements, each prime mover is to be tested at the shop to verify its ability to meet the calculated power requirements. Where the prime mover is a hydraulic motor, in addition to the hydraulic motor, the hydraulic pump is also to be tested at the shop. During the testing, the input/output torque, speed, delivery pressures and flow rates of the pump and the hydraulic motor are to be measured, as appropriate.

- iii) *Brake capacity test.* The holding power of the brake is to be verified either through testing or by calculation.

At the option of the manufacturers, windlass designs and the manufacturing facilities may be approved under the Type Approval Program (see Appendix 1-1-A3).

9 On-board Tests

See 3-7-2/1.

11 Marking (1 July 2018)

Windlasses are to be permanently marked with the following information:

- i) Nominal size of chain (e.g., 100/3/45 is the size designation of a windlass for 100 mm diameter chain cable of Grade 3, with a holding load of 45% of the breaking load of the chain cable).
- ii) Maximum anchorage depth, in meters.

PART
4

CHAPTER 6 Piping Systems

CONTENTS

SECTION 1	General Provisions	429
1	General	429
1.1	Application.....	429
1.3	Organization of Piping Systems Requirements	429
3	Definitions	430
3.1	Piping	430
3.3	Piping System	430
3.5	Piping Components	430
3.7	Pipes	430
3.9	Pipe Schedule	430
3.11	Tubes	430
3.13	Pipe Fittings.....	430
3.15	Valves.....	430
3.16	Positive Closing Valves	430
3.17	Design Pressure.....	431
3.19	Maximum Allowable Working Pressure	431
3.21	Design Temperature.....	431
3.23	Flammable Fluids	431
3.25	Toxic Fluids	431
3.27	Corrosive Fluids	431
3.29	Hazardous and Noxious Liquid Substances	431
5	Classes of Piping Systems	431
7	Certification of Piping System Components	433
7.1	Piping Components	433
7.3	Pumps	434
7.5	Certification Based on the Type Approval Program.....	435
9	Plans and Data to be Submitted	436
9.1	System Plans	436
9.3	Contents of System Plans	436
9.5	Booklet of Standard Details	436
TABLE 1	Classes of Piping Systems	432
TABLE 2	Piping Classes and Certification	433
FIGURE 1	Organization of the Provisions for Piping Systems.....	429

SECTION 2	Metallic Piping	437
1	Application	437
3	Materials	437
3.1	Ferrous	437
3.3	Copper and Copper Alloys	438
3.5	Other Materials	438
5	Design	439
5.1	Pipes	439
5.3	Pipe Branches	441
5.5	Pipe Joints	441
5.7	Flexible Hoses	443
5.8	Expansion Joints	445
5.9	Mechanical Joints	446
5.11	Valves	452
5.13	Safety Relief Valves	453
5.15	Nonstandard Components	453
5.17	Type Approval Program	453
7	Fabrication and Tests	454
7.1	Welded Fabrication	454
7.3	Hydrostatic Tests	454
7.5	Resistance Testing	455
9	Installation Details	455
9.1	Protection from Mechanical Damage	455
9.3	Protection of Electrical Equipment	455
9.5	Provisions for Expansion and Contraction of Piping	455
9.6	Mechanical Joints	456
9.7	Piping Penetrations Through Bulkheads, Decks and Tank Tops	456
9.9	Protection from Overpressure	457
9.11	Temperature and Pressure Sensing Devices	457
9.13	Shell Connections	457
9.15	Control of Static Electricity	459
9.17	Accessibility of Valves	459
9.19	Common Overboard Discharge	459
TABLE 1	Allowable Stress Values S for Steel Pipes	460
TABLE 2	Allowable Stress S for Copper and Copper Alloy Pipes	461
TABLE 3	Corrosion Allowance c for Steel Pipes	461
TABLE 4	Minimum Wall Thickness for Steel Pipes	462
TABLE 5A	Minimum Wall Thickness for Copper and Copper Alloy Pipes	463
TABLE 5B	Minimum Wall Thickness for Austenitic Stainless Steel Pipes	463
TABLE 6	Typical Flange Types	464
TABLE 7	Limitation of Use for Typical Flange Types	465
TABLE 8	Commercial Pipe Sizes and Wall Thicknesses	466
TABLE 9	Examples of Mechanical Joints	467

TABLE 10	Application of Mechanical Joints.....	469
TABLE 11	Application of Mechanical Joints Depending Upon the Class of Piping	471
TABLE 12	Testing Requirements for Mechanical Joints.....	471
FIGURE 1	Socket Welded and Slip-on Welded Sleeve Joints.....	442
FIGURE 2	Straight-thread 'O'-Ring Joints.....	443
FIGURE 3	Arrangement for the Test Rig and the Joint Assembly Specimen Being Tested.....	449
FIGURE 4	Arrangement for the Test Specimen Being Tested in the Test Rig.....	450
FIGURE 5	Distribution of the Pressure Pulses Magnitude % Design Pressure vs. Period Duration	451

SECTION 3	Plastic Piping.....	472
1	General	472
3	Plans and Data to be Submitted	472
3.1	General Information.....	472
3.3	Drawings and Supporting Documentation	472
3.5	Materials.....	473
5	Design.....	473
5.1	Internal Pressure.....	473
5.3	External Pressure.....	473
5.5	Axial Strength.....	473
5.7	Temperature.....	474
5.9	Impact Resistance.....	474
5.11	Fire Endurance.....	474
5.13	Flame Spread.....	475
5.15	Electrical Conductivity	475
5.17	Marking.....	476
7	Installation of Plastic Pipes	476
7.1	Supports.....	476
7.3	External Loads	476
7.5	Plastic Pipe Connections.....	476
7.7	Electrical Conductivity	477
7.9	Shell Connections	477
7.11	Bulkhead and Deck Penetrations	477
7.13	Application of Fire Protection Coatings	477
9	Manufacturing of Plastic Pipes	477
11	Plastic Pipe Bonding Procedure Qualification	478
11.1	Procedure Qualification Requirements.....	478
11.3	Procedure Qualification Testing	478
13	Tests by the Manufacturer – Fire Endurance Testing of Plastic Piping in the Dry Condition (for Level 1 and Level 2)	479
13.1	Test Method	479
13.3	Test Specimen	479
13.5	Test Condition	480
13.7	Acceptance Criteria	480

15	Test by Manufacturer – Fire Endurance Testing of Water-filled Plastic Piping (for Level 3)	480
15.1	Test Method.....	480
15.3	Test Specimen.....	482
15.5	Test Conditions.....	482
15.7	Acceptance Criteria	482
17	Tests by Manufacturer – Flame Spread	483
17.1	Test Method.....	483
19	Testing by Manufacturer – General	483
21	Testing Onboard After Installation	483
TABLE 1	Fire Endurance Requirement Matrix.....	484
TABLE 2	Standards for Plastic Pipes – Typical Requirements for All Systems	486
TABLE 3	Standards for Plastic Pipes – Additional Requirements Depending on Service and/or Location of Piping.....	487
FIGURE 1	Fire Endurance Test Burner Assembly	481
FIGURE 2	Fire Endurance Test Stand with Mounted Sample	481

SECTION 4 Ship Piping Systems and Tanks 488

1	General	488
1.1	Scope	488
1.3	Effective Drainage	488
1.5	Damage Stability Consideration.....	488
3	Gravity Drain Systems	488
3.1	General.....	488
3.3	Protection from Sea Water Entry	489
3.5	Gravity Drains of Cargo Spaces on or Above Freeboard Deck ...	492
3.7	Gravity Drains of Spaces Other than Cargo Spaces.....	492
3.9	Gravity Drains of Non-watertight Spaces.....	493
3.11	Vessels Subject to Damage Stability	493
3.13	Vessels Receiving Subdivision Loadlines.....	493
5	Bilge System	493
5.1	General.....	493
5.3	Bilge System Sizing	493
5.5	Bilge System Design.....	495
5.7	Oil Pollution Prevention Measures.....	498
5.9	Testing and Trials	500
7	Ballast Systems	500
7.1	General.....	500
7.3	Ballast Pumps.....	500
7.5	Ballast Piping and Valves	500
7.7	Ballast Water Treatment Systems	501

9	Tank Vents and Overflows.....	501
9.1	General.....	501
9.3	Tank Vents	502
9.5	Tank Overflows	508
11	Means of Sounding.....	510
11.1	General.....	510
11.3	Sounding Pipes	510
11.5	Gauge Glasses.....	511
11.7	Level Indicating Device	512
11.9	Remote Level Indicating Systems	512
13	Fuel Oil Storage and Transfer Systems.....	512
13.1	General.....	512
13.3	Installation Requirements	513
13.5	Fuel Oil Tanks	514
13.7	Fuel Oil System Components.....	519
13.9	Fuel Oil Transfer, Filling and Purification Systems	521
13.11	Waste Oil Systems for Incinerators	522
15	Lubricating Oil Storage and Transfer Systems	522
15.1	General and Installation Requirements	522
15.3	Lubricating Oil Tanks.....	523
15.5	Lubricating Oil System Components	523
17	Additional Measures for Oil Pollution Prevention	524
17.1	General.....	524
17.3	Tank Protection Requirements	524
17.5	Class Notation – POT.....	525
TABLE 1	Dimensions and Details of Standard Discharge Connection Flange.....	499
TABLE 2	Alternative Arrangements for Fuel Oil Service Tanks.....	516
TABLE 3	Design Pressure for Fuel Oil Pipes.....	519
TABLE 4	Pipe Joint Limitations for Fuel Oil Piping	520
FIGURE 1	Overboard Discharges – Valve Requirements	490
FIGURE 2	SOLAS Vessels – Overboard Discharges from Spaces below Freeboard Deck – Valve Requirements	491
FIGURE 3	Example of Normal Position.....	506
FIGURE 4	Example of Inclination 40 Degrees Opening Facing Upward.....	507
FIGURE 5	Example of Inclination 40 Degrees Opening Facing Downward	507
FIGURE 6	Example of Inclination 40 Degrees Opening Facing Sideways.....	508
FIGURE 7	Acceptable Fuel Oil Tanks Arrangements Inside Category A Machinery Spaces	515

SECTION 5	Piping Systems for Internal Combustion Engines	526
1	Applications	526
3	Fuel Oil Systems	526
3.1	General	526
3.3	Fuel Oil Service System for Propulsion Diesel Engines	527
3.5	Fuel Oil Service System for Auxiliary Diesel Engines	528
3.7	Fuel Oil Service System for Gas Turbines	529
3.9	System Monitoring and Shutdown	529
3.11	Testing and Trials	530
3.13	Use of Natural Gas (NG) in Dual Fuel Diesel Engines and Gas Turbines	530
5	Lubricating Oil Systems	530
5.1	General	530
5.3	Lubricating Oil Systems for Propulsion Engines	530
5.5	Lubricating Oil Systems for Auxiliary Engines	531
5.7	System Monitoring and Safety Shutdown	532
5.9	Testing and Trials	532
7	Cooling System	532
7.1	General	532
7.3	Cooling System Components	532
7.5	Sea Chests	533
7.7	Cooling Systems for Propulsion and Auxiliary Engines	533
7.9	Cooler Installations External to the Hull	534
7.11	Testing and Trials	534
9	Starting Air System	535
9.1	General	535
9.3	Air Compressors	535
9.5	Air Reservoirs	535
9.7	Starting Air Piping	536
9.9	System Alarms	537
9.11	Testing and Trials	537
11	Exhaust Gas Piping	537
11.1	Application	537
11.3	Materials	538
11.5	Insulation	538
11.7	Interconnections	538
11.9	Installation	538
11.11	Diesel Engine Exhaust	538
11.13	Gas Turbines Exhaust	538
11.15	Exhaust Emission Abatement Systems	538
13	Crankcase Ventilation and Drainage	539
13.1	General	539
13.3	Crankcase Vent Piping Arrangement	539
13.5	Crankcase Drainage	539
15	Storage and Use of SCR Reductants	539

TABLE 1	Fuel Oil System Alarms and Shutdown	529
TABLE 2	Lubrication Oil System Basic Alarms and Safety Shutdown	532
TABLE 3	Pipe Joint Limitations for Cooling Water Systems	533
TABLE 4	Required Number of Starts for Propulsion Engines.....	536
TABLE 5	Pipe Joint Limitations for Starting Air Systems	537

SECTION 6	Piping Systems for Steam Plants	540
1	General	540
3	Steam Piping System.....	540
3.1	General.....	540
3.3	Steam Piping Components.....	540
3.5	Steam Piping Design.....	541
3.7	Steam Piping Exceeding 427°C (800°F) Design Temperature	541
3.9	General Installation Details.....	543
3.11	Steam Piping for Propulsion Turbines	543
3.13	Steam Piping for Auxiliary Turbines and Other Services	544
3.15	Blow-off Piping	544
3.17	System Monitoring.....	544
3.19	Testing and Trials.....	544
5	Boiler Feed Water and Condensate Systems.....	544
5.1	General.....	544
5.3	Feed Water System Design.....	545
5.5	Propulsion and Electric Power Generation Boilers	545
5.7	Other Boilers	546
5.9	Condensate System for Propulsion and Power Generation Turbines	546
5.11	System Components	546
5.13	System Monitoring.....	548
5.15	Testing and Trials.....	548
7	Boiler Fuel Oil Piping System	548
7.1	General.....	548
7.3	Fuel Oil Service System for Propulsion Boilers	549
7.5	Fuel Oil Service System for Boilers Essential for Power Generation, Supporting Propulsion and Habitable Conditions	549
7.7	System Monitoring and Shutdown.....	549
7.9	Testing and Trials.....	550
9	Lubricating Oil Systems for Steam Turbines and Reduction Gears	550
9.1	General.....	550
9.3	Lubricating Oil Systems for Propulsion Turbines and Gears	551
9.5	Lubricating Oil Tanks.....	552
9.7	Lubricating Oil Systems for Auxiliary Steam Turbines	552
9.9	System Monitoring and Safety Shutdown.....	552
9.11	Testing and Trials.....	552
11	Sea Water Circulation and Cooling Systems.....	552
11.1	General.....	552
11.3	Condenser Cooling System.....	553

11.5	Lubricating Oil Cooling Systems	553
11.7	Cooling System Components	553
11.9	System Monitoring	553
11.11	Testing and Trials	553
13	Exhaust Gas Piping	553
TABLE 1	Joint Limitations for Steam Piping Systems.....	541
TABLE 2	Pipe Joint Limitations for Feed Water Systems	547
TABLE 3	Fuel Oil System Alarms and Shutdown	550
TABLE 4	Lubricating Oil System Alarms and Safety Shutdown	552

SECTION 7 Other Piping Systems 554

1	General	554
3	Hydraulic Oil Systems	554
3.1	Application	554
3.3	Hydraulic Oil Storage Tanks	554
3.5	Hydraulic System Components	555
3.7	System Requirements	557
3.9	Hydraulic Starting	557
5	Pneumatic Systems	557
5.1	Application	557
5.3	Pneumatic System Components.....	557
5.5	Pneumatic System Requirements.....	558
7	Fixed Oxygen-acetylene Systems	559
7.1	Application	559
7.3	Gas Storage	559
7.5	Piping System Components	559
7.7	Testing.....	560
9	Helicopter Refueling Systems.....	560
9.1	Application	560
9.3	Fuel Storage and Refueling Equipment Area	560
9.5	Spill Containment.....	561
9.7	Fuel Storage Tanks	561
9.9	Refueling Pumps	561
9.11	Fuel Piping.....	561
9.13	Fuel Storage and Refueling Systems Installed in Enclosed Spaces.....	562
9.15	Fire Extinguishing System	562
11	Liquefied Petroleum Gases.....	562
11.1	General.....	562
11.3	Storage Cylinders	562
11.5	Installation and Testing.....	562

TABLE 1	Pipe Joint Limitations for Hydraulic Piping.....	555
TABLE 2	Pipe Joint Limitations for Pneumatic Systems.....	558

PART

4

CHAPTER 6 Piping Systems

SECTION 1 General Provisions

1 General

1.1 Application

The provisions of Part 4, Chapter 6, Section 1 (referred to as Section 4-6-1) apply to all piping systems. These include piping systems covered in Section 4-6-2 through Section 4-6-7, as well as to piping systems in Part 4, Chapter 7 “Fire Safety Systems”, and to piping systems of specialized types of vessels in the applicable sections of Part 5C and Part 5D.

1.3 Organization of Piping Systems Requirements

4-6-1/Figure 1 shows the organization of the provisions for piping systems. These requirements are divided into:

FIGURE 1
Organization of the Provisions for Piping Systems

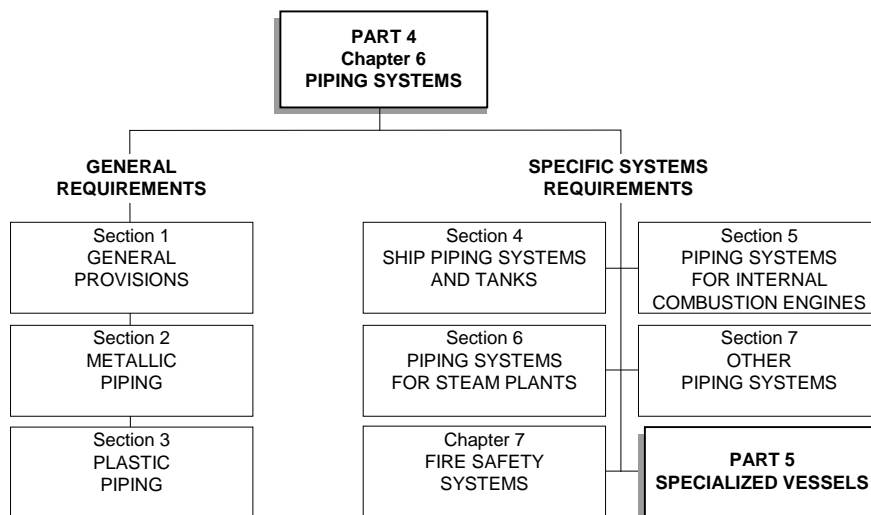

i) General requirements, which include:

- Definitions of terms used throughout these sections, certification requirements of system components and plans to be submitted for review;
- Metallic piping design, pipe components, piping fabrication and testing and general shipboard installation details;
- Plastic piping design, plastic pipe components, plastic piping fabrication and testing.

- ii) Specific systems requirements, which include:
- Bilges and gravity drains piping systems, and piping systems serving tanks (other than cargo tanks); piping systems for storage, transfer and processing of fuel oil and lubricating oil;
 - Piping systems relating to the operation of internal combustion engines;
 - Piping systems relating to the operation of steam turbine and steam generating plants;
 - Other piping systems, such as hydraulic piping system, oxygen-acetylene piping system, etc.;
 - Fire extinguishing systems, which are provided in Part 4, Chapter 7;
 - Cargo piping systems and other piping systems specific to specialized vessel types, which are provided in various chapters in Part 5C and Part 5D.

3 Definitions

3.1 Piping

The term *Piping* refers to assemblies of piping components and pipe supports.

3.3 Piping System

Piping System is a network of piping and any associated pumps, designed and assembled to serve a specific purpose. Piping systems interface with, but exclude, major equipment, such as boilers, pressure vessels, tanks, diesel engines, turbines, etc.

3.5 Piping Components

Piping Components include pipes, tubes, valves, fittings, flanges, gaskets, bolting, hoses, expansion joints, sight flow glasses, filters, strainers, accumulators, instruments connected to pipes, etc.

3.7 Pipes

Pipes are pressure-tight cylinders used to contain and convey fluids. Where the word 'pipe' is used in this section, it means pipes conforming to materials and dimensions as indicated in Section 2-3-12, Section 2-3-13, Section 2-3-16 and Section 2-3-17 of the *ABS Rules for Materials and Welding (Part 2)*, or equivalent national standards such as ASTM, BS, DIN, JIS, etc.

3.9 Pipe Schedule

Pipe Schedules are designations of pipe wall thicknesses as given in American National Standard Institute, ANSI B36.10. Standard and extra heavy (extra strong) pipes, where used in these sections, refer to Schedule 40 and Schedule 80, up to maximum wall thicknesses of 9.5 mm (0.375 in.) and 12.5 mm (0.5 in.), respectively. For a listing of commercial pipe sizes and wall thicknesses, see 4-6-2/Table 8.

3.11 Tubes

Tubes are generally small-diameter thin-wall pipes conforming to an appropriate national standard. Tubes are to meet the same general requirements as pipes.

3.13 Pipe Fittings

Pipe Fittings refer to piping components such as sleeves, elbows, tees, bends, flanges, etc., which are used to join together sections of pipe.

3.15 Valves

The term *Valve* refers to gate valves, globe valves, butterfly valves, etc., which are used to control the flow of fluids in a piping system. For the purpose of these Rules, test cocks, drain cocks and other similar components which perform the same function as valves are considered valves.

3.16 Positive Closing Valves

Positive Closing Valves are valves that are capable of maintaining a set position under all operating conditions.

3.17 Design Pressure

Design Pressure is the pressure to which each piping component of a piping system is designed. It is not to be less than the pressure at the most severe condition of coincidental internal or external pressure and temperature (maximum or minimum) expected during service. However, the Rules do impose in some instances a specific minimum design pressure that exceeds the maximum expected service pressure, see for example 4-6-4/13.7 for heated fuel oil systems.

3.19 Maximum Allowable Working Pressure

The *Maximum Allowable Working Pressure* is the maximum pressure of a piping system determined, in general, by the weakest piping component in the system or by the relief valve setting. The maximum allowable working pressure is not to exceed the design pressure.

3.21 Design Temperature

The *Design Temperature* is the maximum temperature at which each piping component is designed to operate. It is not to be less than the temperature of the piping component material at the most severe condition of temperature and coincidental pressure expected during service. For purposes of the Rules, it may be taken as the maximum fluid temperature.

For piping used in a low-temperature application, the design temperature is to include also the minimum temperature at which each piping component is designed to operate. It is not to be higher than the temperature of the piping component material at the most severe condition of temperature and coincidental pressure expected during service. For the purposes of the Rules, it may be taken as the minimum fluid temperature.

For all piping, the design temperature is to be used to determine allowable stresses and material testing requirements.

3.23 Flammable Fluids

Any fluid, regardless of its flash point, liable to support a flame is to be treated as a flammable fluid for the purposes of Section 4-6-1 through Section 4-6-7. Aviation fuel, diesel fuel, heavy fuel oil, lubricating oil and hydraulic oil (unless the hydraulic oil is specifically specified as non-flammable) are all to be considered flammable fluids.

3.25 Toxic Fluids

Toxic fluids are those that are liable to cause death or severe injury or to harm human health if swallowed or inhaled or by skin contact.

3.27 Corrosive Fluids

Corrosive fluids, excluding seawater, are those possessing in their original state the property of being able through chemical action to cause damage by coming into contact with living tissues, the vessel or its cargoes, when escaped from their containment.

3.29 Hazardous and Noxious Liquid Substances

Hazardous and noxious liquid substances are the cargoes containing products or mixtures of such products listed in Chapters 17 and 18 of the *International Code for the Construction and Equipment of Ships Carrying Dangerous Chemicals in Bulk (IBC Code)*, (see Section 5C-9-19).

Hazardous and noxious liquid substances are also permitted to be carried under the IMO Resolution A.673(16) "Guidelines for the Transport and Handling of Limited Amounts of Hazardous and Noxious Liquid Substances in Bulk in Offshore Support Vessels" as amended by IMO Resolutions MSC.236(82) and MEPC.158(55).

5 Classes of Piping Systems

Piping systems are divided into three classes according to service, design pressure and temperature, as indicated in 4-6-1/Table 1. Each class has specific requirements for joint design, fabrication and testing. The requirements in this regard are given in Section 4-6-2 for metallic piping. For plastic piping, see Section 4-6-3.

TABLE 1
Classes of Piping Systems

Piping Class →	Class I $P > P_2$ OR $T > T_2$		Class II Bounded by Class I and Class III - see chart above		Class III $P \leq P_1$ AND $T \leq T_1$	
Piping System ↓	bar, (kgf/cm ² , psi)	°C (°F)	bar, (kgf/cm ² , psi)	°C (°F)	bar, (kgf/cm ² , psi)	°C (°F)
Corrosive fluids	Without special safeguards		With special safeguard		Not applicable	
Toxic fluids	All		Not applicable		Not applicable	
Flammable liquids heated to above flash point or having flash point 60°C or less	Without special safeguards		With special safeguards		Open-ended piping	
Liquefied gas	Without special safeguards		With special safeguards		Open-ended piping	
Steam	16 (16.3, 232)	300 (572)	See chart		7 (7.1, 101.5)	170 (338)
Thermal oil	16 (16.3, 232)	300 (572)	See chart		7 (7.1, 101.5)	150 (302)
Fuel oil Lubricating oil Flammable hydraulic oil	16 (16.3, 232)	150 (302)	See chart		7 (7.1, 101.5)	60 (140)
Cargo oil piping in cargo area	Not applicable		Not applicable		All	
Other fluids (including water, air, gases, non-flammable hydraulic oil)	40 (40.8, 580)	300 (572)	See chart		16 (16.3, 232)	200 (392)
Open ended pipes (drains, overflows, vents, exhaust gas lines, boilers escapes pipes)	Not applicable		Not applicable		All	
Fixed Oxygen-acetylene System	High pressure side		Not applicable		Low pressure side	

Notes:

- 1 The above requirements are not applicable to piping systems intended for liquefied gases in cargo and process areas.
- 2 The above requirements are also not applicable to cargo piping systems of vessels carrying chemicals in bulk.
- 3 Safeguards are measures undertaken to reduce leakage possibility and limiting its consequences, (e.g., double wall piping or equivalent, or protective location of piping etc.)

7 Certification of Piping System Components

7.1 Piping Components

Piping components are to be certified in accordance with 4-6-1/Table 2 and the following.

7.1.1 ABS Certification

Where indicated as 'required' in 4-6-1/Table 2, the piping component is to be certified by ABS. This involves design approval of the component, as applicable, and testing in accordance with the standard of compliance at the manufacturer's plant. Such components may also be accepted under the Type Approval Program, see 4-6-1/7.5.

7.1.2 Design Approval

Design approval is a part of the ABS certification process and where indicated as 'required' in 4-6-1/Table 2, the piping components are to meet an applicable recognized standard, or are to be design-approved by ABS. For the latter purpose, pipe fittings and valves are to be evaluated for their adequacy for the rated pressures and temperatures, and, as applicable, type inspection and testing are to be conducted as part of the design evaluation process. See also 4-6-1/7.5, 4-6-2/5 and 4-6-3/5.

7.1.3 Manufacturer's Certification

Where indicated as 'required' in 4-6-1/Table 2, the manufacturer is to certify that the piping component complies with the standard to which the component is designed, fabricated and tested, and to report the results of tests so conducted. For Class III components, manufacturer's trademark, pressure/temperature rating and material identification, as applicable, stamped or cast on the component and verifiable against the manufacturer's catalog or similar documentation will suffice.

7.1.4 Identification

Where indicated as 'permanent' in 4-6-1/Table 2, the piping component is to bear permanent identification, such as manufacturer's name or trademark, standard of compliance, material identity, pressure rating, etc., as required by the standard of compliance or the manufacturer's specification. Such markings may be cast or forged integral with, stamped on, or securely affixed by nameplate on the component, and are to serve as a permanent means of identification of the component throughout its service life.

Where indicated as 'temporary', the pipe is to have identification for traceability during fabrication.

TABLE 2
Piping Classes and Certification

<i>Piping Component</i>	<i>Class</i>	<i>ABS Certification</i> ⁽¹⁾	<i>Design Approval</i> ⁽¹⁾	<i>Manufacturer's Certification</i> ⁽¹⁾	<i>Identification</i> ⁽¹⁾
Pipes	I, II	Required ⁽²⁾	Not applicable ⁽³⁾	Required	Temporary ⁽³⁾
	III	Not required ⁽³⁾	Not applicable ⁽³⁾	Required	Temporary ⁽³⁾
Pipe fittings	I, II	Not required	Required ^(4, 6)	Required	Permanent
	III	Not required	Not required ^(5, 6)	Required	Permanent
Valves	I, II	Not required	Required ⁽⁴⁾	Required	Permanent
	III	Not required	Not required ⁽⁵⁾	Required	Permanent

Notes:

- 1 See 4-6-1/7.1.1, 4-6-1/7.1.2, 4-6-1/7.1.3 and 4-6-1/7.1.4.
- 2 Except hydraulic piping.
- 3 Except for plastic piping. See Section 4-6-3.
- 4 Where not in compliance with a recognized standard.
- 5 Documentary proof of pressure/temperature rating is required. See 4-6-2/5.15.
- 6 Design of flexible hoses and mechanical pipe joints is to be approved in each case. See 4-6-2/5.7 and 4-6-2/5.9, respectively.

7.3 Pumps

7.3.1 Pumps Requiring Certification

The pumps listed below are to be certified by a Surveyor at the manufacturers' plants:

- i)* Pumps for all vessels (500 gross tonnage and over):
 - Fuel oil transfer pumps
 - Hydraulic pumps for steering gears (see also 4-3-4/19.5), anchor windlasses, controllable pitch propellers
 - Fire pumps, including emergency fire pumps
 - Other fire fighting service pumps, such as, pumps for fixed water-based systems, or equivalent, local application fire-fighting systems (see 4-7-2/1.11.2), sprinkler systems (see 4-7-3/9.5.3), deck foam systems, etc.
 - Bilge pumps
 - Ballast pumps
- ii)* Pumps associated with propulsion diesel engine and reduction gears (for engines with bores > 300 mm only):
 - Fuel oil service pumps, booster pumps, etc.
 - Sea water and freshwater cooling pumps
 - Lubricating oil pumps
- iii)* Pumps associated with steam propulsion and reduction gears:
 - Fuel oil service pumps
 - Main condensate pumps
 - Main circulating pumps
 - Main feed pumps
 - Vacuum pumps for main condenser
 - Lubricating oil pumps
- iv)* Pumps associated with propulsion gas turbine and reduction gears:
 - Fuel oil service pumps
 - Lubricating oil pumps
- v)* Cargo pumps associated with oil carriers, liquefied gas carriers and chemical carriers.
 - Cargo pumps associated with liquefied gas carriers, see 5C-8-5/13.1.3
- vi)* Pumps associated with inert gas systems:
 - Fuel oil pumps for boilers/inert gas generators
 - Cooling water pumps for flue gas scrubber
- vii)* Cargo pumps associated with systems handling the following:
 - Safety Hazard Substances (see 5D-2-3/5.11) or;
 - Flammable Liquids (see 5D-2-3/5.13)

7.3.2 Required Tests

The following tests are to be carried out at the manufacturer's plant in the presence of the Surveyor.

7.3.2(a) *Hydrostatic tests.* The pumps are to be hydrostatically tested to a pressure of at least $1.5P$, where P is the maximum working pressure of the pump. If it is desired to conduct the hydrostatic test on the suction side of the pump independently from the test on the discharge side, the test pressure on the suction side is to be at least $1.5P_s$, where P_s is the maximum pressure available from the system at the suction inlet. In all cases, the test pressure for both the suction and the discharge side is not to be less than 4 bar.

7.3.2(b) *Capacity tests.* Pump capacities are to be checked with the pump operating at design conditions (rated speed and pressure head). For centrifugal pumps, the pump characteristic (head-capacity) design curve is to be verified to the satisfaction of the Surveyor. Capacity tests may be waived if previous satisfactory tests have been carried out on similar pumps.

7.3.2(c) *Relief valve capacity test.* For positive displacement pumps with an integrated relief valve, the valve's setting and full flow capacity corresponding to the pump maximum rating is to be verified. The operational test for relief valve capacity may be waived if previous satisfactory tests have been carried out on similar pumps.

7.5 Certification Based on the Type Approval Program

7.5.1 Pipes

For pipes which are required to be ABS certified in accordance with 4-6-1/Table 2, the manufacturer may request that ABS approve and list them under the Type Approval Program described in Appendix 1-1-A3 of the *ABS Rules for Conditions of Classification (Part 1)*. Upon approval under 1-1-A3/5.5 (PQA) and listing under this program, the pipes will not be required to be surveyed and certified each time they are manufactured for use onboard a vessel.

To be considered for approval under this program, the manufacturer is to operate a quality assurance system that is certified for compliance with a recognized quality standard. In addition, quality control of the manufacturing processes is to cover all of the provisions of inspection and tests required by the Rules and applicable pipe standard, in accordance with 1-1-A3/5.5.

7.5.2 Pipe Fittings and Valves

For pipe fittings and valves which are not required to be certified but are required to be design approved in accordance with 4-6-1/Table 2, the manufacturer may request that ABS approve and list the component as a Design Approved Product described in 1-1-A3/5.1. The design is to be evaluated in accordance with 4-6-1/7.1.2. Upon approval and listing, and subject to renewal and updating of the certificates as required by 1-1-A3/5.7, it will not be necessary to submit the design of the component for approval each time it is proposed for use onboard a vessel.

The manufacturer may also request that the product be approved and listed under the Type Approval Program. In this case, in addition to the design approval indicated above, the manufacturer is to provide documented attestation that the product will be manufactured to consistent quality and to the design and specifications to which it is approved. See 1-1-A3/5.3 (AQS)/(RQS) or 1-1-A3/5.5 (PQA).

7.5.3 Pumps

As an alternative to certification specified in 4-6-1/7.3.2 for mass-produced pumps, the manufacturer may request that ABS design assesses and list the pump under the Type Approval Program. To be design assessed under this program:

- i) The manufacturer may submit drawings and apply for a Product Design Assessment based on compliance with recognized standards as specified in 1-1-A3/5.1 of the Rules,
- ii) A sample of the pump type is to be subjected to hydrostatic and capacity tests, and relief valve capacity test specified in 4-6-1/7.3.2. Pumps so assessed may be accepted by ABS for listing on ABS website in the Design Approved Products Index (DA),
- iii) The manufacturer is to operate a quality assurance system which is to be certified for compliance with a quality standard in accordance with 1-1-A3/5.3(AQS)/(RQS) or 1-1-A3/5.5 (PQA). The quality control plan is to have provisions to subject each production unit of the pump to tests specified in 4-6-1/7.3.2 and the manufacturer is to submit record of such tests to the local ABS office who will finalize the Unit Certification. Pumps that meet this requirement will be listed in the ABS Type Approval.

9 Plans and Data to be Submitted

9.1 System Plans

The following plans are to be submitted for review:

- Propulsion machinery space arrangement, including locations of fuel oil tanks
- Booklet of standard details (see 4-6-1/9.5)
- Ballast system
- Bilge and drainage systems
- Boiler feed water and condensate systems
- Compressed air system
- Cooling water systems
- Exhaust piping (for boilers, incinerators and engines)
- Fixed oxygen-acetylene system
- Fuel oil systems, including storage tanks, drip trays and drains
- Helicopter refueling system, fuel storage tank and its securing and bonding arrangements
- Hydraulic and pneumatic systems
- Lubricating oil systems
- Sanitary system
- Sea water systems
- Vent, overflow and sounding arrangements
- Steam systems
- Steam piping analyses (as applicable)
- Tank venting and overflow systems
- All Class I and Class II piping systems not covered above

9.3 Contents of System Plans

Piping system plans are to be diagrammatic and are to include the following information:

- Types, sizes, materials, construction standards, and pressure and temperature ratings of piping components other than pipes
- Materials, outside diameter or nominal pipe size, and wall thickness or schedule of pipes
- Design pressure and design temperature, test pressure
- Maximum pump pressures and/or relief valve settings
- Flash point of flammable liquids
- Instrumentation and control
- Legend for symbols used

9.5 Booklet of Standard Details

The booklet of standard details, as indicated in 4-6-1/9.1, is to contain standard practices to be used in the construction of the vessel, typical details of such items as bulkhead, deck and shell penetrations, welding details, pipe joint details, etc. This information may be included in the system plans, if desired.

PART

4

CHAPTER 6 Piping Systems

SECTION 2 Metallic Piping

1 Application

The provisions of Part 4, Chapter 6, Section 2 (referred to as Section 4-6-2) cover metallic piping. They include requirements for piping materials, design, fabrication, inspection and testing. They also include general requirements for shipboard installation practices. Requirements for plastic piping are provided in Section 4-6-3.

3 Materials

While references are made to material specifications in Sections 2-3-12, 2-3-13, 2-3-16 and 2-3-17, equivalent materials complying with a national or international standard will be considered for acceptance.

3.1 Ferrous

3.1.1 Steel Pipes

3.1.1(a) Material specifications. Material specifications for acceptable steel pipes are in Section 2-3-12. Materials equivalent to these specifications will be considered.

3.1.1(b) Application of seamless and welded pipes. The application of seamless and welded pipes is to be in accordance with the following table:

	<i>Seamless Pipes</i>	<i>Electric Resistance Welded Pipes</i>	<i>Furnace Butt Welded Pipes</i>
Class I	permitted	permitted	not permitted
Class II	permitted	permitted	not permitted
Class III	permitted	permitted	permitted ⁽¹⁾

Note: 1 Except for flammable fluids.

3.1.2 Forged and Cast Steels

Material specifications for steel forgings and steel castings are given in Section 2-3-7 and Section 2-3-9, respectively. There is no service limitation except as indicated in 4-6-2/3.1.5 and 4-6-2/3.1.6.

3.1.3 Gray Cast Iron

Material specifications for gray cast iron (also called ordinary cast iron) are given in Section 2-3-11. Cast iron components should not be used in systems that are exposed to pressure shock, vibration or excessive strain. In general, gray cast iron pipes, valves and fittings may be used only in Class III piping systems. Specifically, gray cast iron is not to be used for the following applications:

- Valves and fittings for temperatures above 220°C (428°F)
- Valves connected to the collision bulkhead (see 4-6-2/9.7.3)
- Valves connected to the shell of the vessel (see 4-6-2/9.13.2)
- Valves fitted on the outside of fuel oil, lubricating oil, cargo oil and hydraulic oil tanks where subjected to a static head of oil [see, for example, 4-6-4/13.5.3(a)]

- Valves mounted on boilers except
- Pipes, valves and fittings in cargo oil piping on weather decks for pressures exceeding 16 bar (16.3 kgf/cm², 232 psi) [see 5C-1-7/3.3.2(e)]
- Pipes, valves and fittings in cargo oil manifolds for connection to cargo handling hoses [see 5C-1-7/3.3.2(e)]
- Fixed gas fire extinguishing systems

3.1.4 Nodular (Ductile) Iron

Material specifications for nodular iron are given in Section 2-3-10. Nodular iron is not permitted for the construction of valves and fittings for temperatures of 350°C (662°F) and above.

Nodular iron may be used for Classes I and II piping systems and for valves listed in 4-6-2/3.1.3 provided it has an elongation of not less than 12% in 50 mm (2 in.).

3.1.5 Elevated Temperature Applications

In general, carbon and carbon-manganese steel pipes, valves and fittings for pressure service are not to be used for temperatures above 400°C (752°F) unless their metallurgical behavior and time dependent strengths are in accordance with national or international codes or standards and that such behavior and strengths are guaranteed by the steel manufacturers.

Consideration is to be given to the possibility of graphite formation in the following steels:

- Carbon steel above 425°C (797°F)
- Carbon-molybdenum steel above 470°C (878°F)
- Chrome-molybdenum steel (with chromium under 0.60%) above 525°C (977°F)

3.1.6 Low Temperature Applications

Ferrous materials used in piping systems operating at lower than –18°C (0°F) are to have adequate notch toughness properties. Specifications of acceptable materials are in Section 2-3-13. Materials for piping systems of liquefied gas carriers are to comply with 5C-8-5/12.

3.3 Copper and Copper Alloys

Material specifications for copper and copper alloy pipes and castings are given in Section 2-3-14, Section 2-3-16 and Section 2-3-17.

Copper and copper alloys are not to be used for fluids having a temperature greater than the following:

Copper-nickel:	300°C (572°F)
High temperature bronze:	260°C (500°F)
All other copper and copper alloys:	200°C (392°F)

Copper and copper alloy pipes may be used for Classes I and II systems, provided they are of the seamless drawn type. Seamless drawn and welded copper pipes are acceptable for Class III systems.

3.5 Other Materials (1 July 2018)

Piping containing flammable fluids is to be constructed of steel or other materials approved by ABS. Other equivalent material with a melting point above 930°C (1706°F) and with an elongation above 12% may be accepted. Aluminum and aluminum alloys which are characterized by low melting points, below 930°C (1706°F), are considered heat sensitive materials and are not to be used to convey flammable fluids, except for such piping as arranged inside cargo tanks or heat exchangers or as otherwise permitted for engine, turbine and gearbox installations, see 4-2-1/7.7.

On oil tankers and chemical tankers aluminized pipes are prohibited in cargo tanks, cargo deck tank area, pump rooms, cofferdams, or other areas where cargo vapor may accumulate. Aluminized pipes may be permitted in ballast tanks, in inerted cargo tanks, and, provided the pipes are protected from accidental impact, in hazardous areas on open deck.

5 Design

5.1 Pipes

The wall thickness of a pipe is not to be less than the greater of the value obtained by 4-6-2/5.1.1 or 4-6-2/5.1.3. However, 4-6-2/5.1.2 may be used as an alternative to 4-6-2/5.1.1.

5.1.1 Pipes Subject to Internal Pressure

The minimum wall thickness is not to be less than that calculated by the following equations or that specified in 4-6-2/5.1.3, whichever is greater. Units of measure are given in the order of SI (MKS, US) units, respectively. The use of these equations is subject to the following conditions:

- The following requirements apply for pipes where the outside to inside diameter ratio does not exceed a value of 1.7.
- Ferrous materials are to be those that have specified elevated temperature tensile properties required below.

$$t = (t_0 + b + c)m$$

$$t_0 = \frac{PD}{KSe + P}$$

where

t = minimum required pipe wall thickness (nominal wall thickness less manufacturing tolerance) ; mm (in.)

t_0 = minimum required pipe wall thickness due to internal pressure only; mm (in.)

P = design pressure; bar (kgf/cm², psi)

D = outside diameter of pipe; mm (in.)

K = 20 (200, 2) for SI (MKS, US) units of measure, respectively

S = permissible stress; N/mm² (kgf/mm², psi); to be determined by a) or b) below:

- a) Carbon steel and alloy steel pipes with a specified minimum elevated temperature yield stress or 0.2% proof stress: S is to be the lowest of the following three values:

$$\frac{\sigma_T}{2.7} \quad \frac{\sigma_Y}{1.8} \quad \frac{\sigma_R}{1.8}$$

where

σ_T = specified minimum tensile strength at room temperature, i.e., 20°C (68°F).

σ_Y = specified minimum yield strength at the design temperature.

σ_R = average stress to produce rupture in 100,000 hours at the design temperature.

- b) Copper and copper alloys: S is to be in accordance with 4-6-2/Table 2.

e = efficiency factor, to be equated to:

1.0 for seamless pipes

1.0 for electric-resistance welded pipes manufactured to a recognized standard

0.6 for furnace butt-welded pipes

For other welded pipes, the joint efficiency is to be determined based on the welding procedure and the manufacturing and inspection processes.

b = allowance for bending; mm (in.). The value for b is to be chosen in such a way that the calculated stress in the bend, due to the internal pressure only, does not exceed the permissible stress. When the bending allowance is not determined by a more accurate method, it is to be taken as:

$$b = 0.4 \frac{D}{R} t_0$$

R = mean radius of the bend; mm (in.)

c = corrosion allowance; mm (in.); to be determined as follows:

- For steel pipes, the value for c is to be in accordance with 4-6-2/Table 3.
- For non-ferrous metal pipes (excluding copper-nickel alloys containing 10% or more nickel), $c = 0.8$ mm (0.03 in.).
- For copper-nickel alloys containing 10% or more nickel, $c = 0.5$ mm (0.02 in.).
- Where the pipe material is corrosion resistant with respect to the media, e.g., special alloy steel, $c = 0$.

m = coefficient to account for negative manufacturing tolerance when pipe is ordered by its nominal wall thickness, calculated as follows:

$$= \frac{100}{100 - a}$$

a = percentage negative manufacturing tolerance, or 12.5% where a is not available

5.1.2 Pipes Subject to Internal Pressure – Alternative Equation

As an alternative to 4-6-2/5.1.1, for steel pipe specifications in Section 2-3-12, the minimum wall thickness may be determined by the following equations or that specified in 4-6-2/5.1.3, whichever is greater. Units of measure are given in the order of SI (MKS, US) units, respectively.

$$t = \frac{PD}{KS + MP} + c$$

where

P , D , K , t are as defined in 4-6-2/5.1.1; and

P = for calculation purpose, not to be taken as less than 8.6 bar, 8.8 kgf/cm² (125 psi)

S = allowable stress from 4-6-2/Table 1; N/mm² (kgf/mm², psi).

M = factor, from 4-6-2/Table 1.

c = allowance for threading grooving or mechanical strength, and is to be as given below:

- Plain end pipe ≤ 100 mm (4 in.) NB: 1.65 mm (0.065 in.)
- Plain end pipe ≤ 100 mm (4 in.) NB for hydraulic oil service: 0
- Plain end pipe > 100 mm (4 in.) NB: 0
- Threaded pipe ≤ 9.5 mm ($3/8$ in.) NB: 1.27 mm (0.05 in.)
- Threaded pipe > 9.5 mm ($3/8$ in.) NB: $[0.8 \times (\text{mm per thread})]$ or $[0.8 \div (\text{threads per in.})]$
- Grooved pipe: depth of groove

The above method of calculation may also be used for determining required wall thickness for pipes of other materials. In such cases, the value of S may be obtained from ANSI B31.1 *Code for Power Piping*.

5.1.3 Minimum Pipe Wall Thickness and Bending

Notwithstanding 4-6-2/5.1.1 or 4-6-2/5.1.2, the minimum wall thickness of pipes is not to be less than that indicated in 4-6-2/Table 4 for steel pipes, and 4-6-2/Tables 5A and 5B for other metal pipes. The wall thicknesses listed in these tables are nominal wall thicknesses. When using the tables, no allowances need be made to account for negative tolerance or reduction in thickness due to bending.

Pipe bending is to be in accordance with 2-3-12/25 of the *Rules for Materials and Welding (Part 2)*. Alternatively, bending in accordance with a recognized standard (e.g., ASME B31.1 - Section 129.1 and 129.3) or other approved specifications to a radius that will result in a surface free of cracks and substantially free of buckles may be acceptable.

5.3 Pipe Branches

Pipe branches may be made by the use of standard branch fittings or by welded fabrication. In the case of welded fabrication, the main pipe is weakened by the hole that must be made in it to accommodate the branch pipe. The opening is to be compensated as follows:

- Excess wall thickness, over and above the minimum required wall thickness of the main pipe and the branch required for pressure service (disregarding corrosion allowance and manufacturing tolerances) determined by the equation in 4-6-2/5.1.1 or 4-6-2/5.1.2 may be considered for this purpose.
- The opening may be compensated with reinforcement pads.

The opening and its compensation may be designed in accordance with the criteria of opening reinforcement of a pressure vessel. See, for example, 4-4-1A1/7.

5.5 Pipe Joints

5.5.1 Butt Welded Joints

Butt welded joints, where complete penetration at the root is achieved, may be used for all classes of piping. Degree of verification of sound root penetration is to be in accordance with 2-4-4/5 and 2-4-4/11.

5.5.2 Socket Welded Joints

Socket welded joints using standard fittings may be used for Classes I and II piping up to and including 80 mm (3 in) nominal diameter, except in toxic and corrosive fluid services (see 4-6-1/3.25 and 4-6-1/3.27) or services where fatigue, severe erosion or crevice corrosion is expected to occur. Socket welded joints using standard fittings may be used for Class III piping without limitation. The fillet weld leg size is to be at least 1.1 times the nominal thickness of the pipe. See 4-6-2/Figure 1.

5.5.3 Slip-on Welded Sleeve Joints

Slip-on welded sleeve joints may be used for Classes I and II piping up to and including 80 mm (3 in.) nominal diameter except in toxic and corrosive fluid services (see 4-6-1/3.25 and 4-6-1/3.27) or services where fatigue, severe erosion or crevice corrosion is expected to occur, provided that:

- The inside diameter of the sleeve is not to exceed the outside diameter of the pipe by more than 2 mm (0.08 in.).
- The depth of insertion of the pipe into the sleeve is to be at least 9.5 mm (0.375 in.).
- The gap between the two pipes is to be at least 2 mm (0.08 in.).
- The fillet weld leg size is as per 4-6-2/5.5.2, see 4-6-2/Figure 1.

Slip-on welded sleeve joints may be used for Class III piping without size limitation. In such cases, joint design and attachment weld sizes may be in accordance with a recognized alternative standard.

FIGURE 1
Socket Welded and Slip-on Welded Sleeve Joints

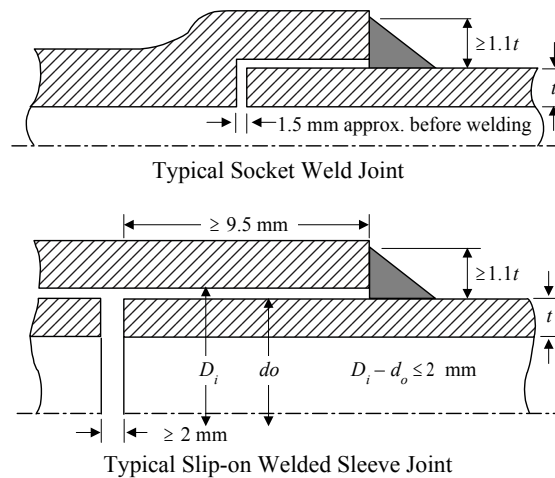

5.5.4 Flanged Joints

Flanges of all types (see 4-6-2/Table 6 for typical types) conforming to and marked in accordance with a recognized national standard may be used within the pressure-temperature ratings of the standard, subject to limitations indicated in 4-6-2/Table 7. For flanges not conforming to a recognized standard, calculations made to a recognized method are to be submitted for review. Non-standard flanges are to be subjected to the same limitations indicated in 4-6-2/Table 7.

Flanges conforming to a standard are to be attached to pipes by welding or other acceptable means as specified in the standard. Non-standard flanges are to be attached to pipes by a method approved with the design.

5.5.5 Threaded Joints

5.5.5(a) Taper-thread joints. Threaded joints having tapered pipe threads complying with a recognized standard are not to be used for toxic and corrosive fluid services and for all services of temperatures exceeding 495°C (923°F). They may be used for Classes I and II piping subject to limitations indicated in the table below. They may be used for Class III piping without limitation. For hydraulic oil system, see 4-6-7/Table 1.

Pipe Nominal Diameter, <i>d</i>		Maximum Pressure Permitted		
<i>mm</i>	<i>in.</i>	<i>bar</i>	<i>kgf/cm²</i>	<i>psi</i>
$d > 80$	$d > 3$	Not permitted for Classes I & II		
$80 \geq d > 50$	$3 \geq d > 2$	27.6	28.1	400
$50 \geq d > 25$	$2 \geq d > 1$	41.4	42.2	600
$25 \geq d > 20$	$1 \geq d > 0.75$	82.8	84.4	1200
$d \leq 20$	$d \leq 0.75$	103	105.5	1500

5.5.5(b) Taper-thread joints for hydraulic oil system. Taper-thread joints up to 80 mm (3 in.) nominal diameter may be used without pressure limitation for connection to equipment only, such as pumps, valves, cylinders, accumulators, gauges and hoses. When such fittings are used solely to join sections of pipe, they are to be in accordance with 4-6-2/5.5.5(a). However, hydraulic systems for the following services are to comply with 4-6-2/5.5.5(a) in all respects:

- Steering gear hydraulic systems
- Controllable pitch propeller hydraulic systems
- Hydraulic systems associated with propulsion or propulsion control

5.5.5(c) *Straight-thread 'o'-ring joints.* For hydraulic oil piping, straight thread 'o'-ring type fittings (see 4-6-2/Figure 2) may also be used for connections to equipment, without pressure and service limitation, but are not to be used for joining sections of pipe.

FIGURE 2
Straight-thread 'O'-Ring Joints

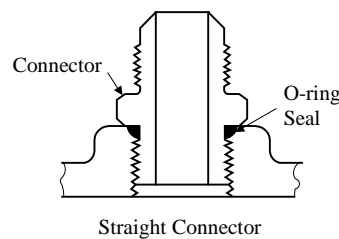

5.7 Flexible Hoses

5.7.1 Definition

A flexible hose assembly is a short length of metallic or non-metallic hose normally with prefabricated end fittings ready for installation.

5.7.2 Scope

The requirements of 4-6-2/5.7.3 to 4-6-2/5.7.6 apply to flexible hoses of metallic or non-metallic material intended for a permanent connection between a fixed piping system and items of machinery. The requirements also apply to temporary connected flexible hoses or hoses of portable equipment.

Flexible hose assemblies as defined in 4-6-2/5.7.1 are acceptable for use in oil fuel, lubricating, hydraulic and thermal oil systems, fresh water and sea water cooling systems, compressed air systems, bilge and ballast systems, and Class III steam systems where they comply with 4-6-2/5.7.3 to 4-6-2/5.7.6.

Flexible hoses are not acceptable in high pressure fuel oil injection systems.

These requirements for flexible hose assemblies are not applicable to hoses intended to be used in fixed fire extinguishing systems.

5.7.3 Design and Construction

5.7.3(a) *Hose material.* Flexible hoses are to be designed and constructed in accordance with recognized National or International standards acceptable to ABS. Flexible hoses constructed of rubber or plastics materials and intended for use in bilge, ballast, compressed air, oil fuel, lubricating, hydraulic and thermal oil systems are to incorporate a single or double closely woven integral wire braid or other suitable material reinforcement. Where rubber or plastics materials hoses are to be used in oil supply lines to burners, the hoses are to have external wire braid protection in addition to the integral reinforcement. Flexible hoses for use in steam systems are to be of metallic construction.

5.7.3(b) *Hose end fittings.* Flexible hoses are to be complete with approved end fittings in accordance with manufacturer's specification. Flanged end connections are to comply with 4-6-2/5.5.4 and threaded end connections with 4-6-2/5.5.5, as applicable and each type of hose/fitting combination is to be subject to prototype testing to the same standard as that required by the hose with particular reference to pressure and impulse tests.

The use of hose clamps and similar types of end attachments is not acceptable for flexible hoses in piping systems for steam, flammable media, starting air or for sea water where failure may result in flooding. In other piping systems, the use of hose clamps may be accepted where the working pressure is less than 5 bar (5.1 kgf/cm², 72.5 psi) and provided there are at least two stainless steel hose clamps at each end connection. The hose clamps are to be at least 12 mm (0.5 in.) wide and are not to be dependent upon spring tension to remain fastened.

5.7.3(c) *Fire resistance.* Flexible hose assemblies constructed of non-metallic materials intended for installation in piping systems for flammable media and sea water systems where failure may result in flooding, are to be of a fire-resistant type*, except in cases where such hoses are installed on open decks, as defined in SOLAS II-2/Reg. 9.2.3.3.2.2(10) and not used for fuel oil lines. Fire resistance is to be demonstrated by testing to ISO 15540 and ISO 15541.

* *Note:* The installation of a shutoff valve immediately upstream of a sea water hose does not satisfy the requirement for fire-resistant type hose.

5.7.3(d) *Hose application.* Flexible hose assemblies are to be selected for the intended location and application taking into consideration ambient conditions, compatibility with fluids under working pressure and temperature conditions consistent with the manufacturer's instructions and other relevant requirements of this Section.

Flexible hose assemblies intended for installation in piping systems where pressure pulses and/or high levels of vibration are expected to occur in service, are to be designed for the maximum expected impulse peak pressure and forces due to vibration. The tests required by 4-6-2/5.7.5 are to take into consideration the maximum anticipated in-service pressures, vibration frequencies and forces due to installation.

5.7.4 Installation

In general, flexible hoses are to be limited to a length necessary to provide for relative movement between fixed and flexibly mounted items of machinery, equipment or systems.

Flexible hose assemblies are not to be installed where they may be subjected to torsion deformation (twisting) under normal operating conditions.

The number of flexible hoses, in piping systems is to be kept to minimum and is to be limited for the purpose stated in 4-6-2/5.7.2.

Where flexible hoses are intended to be used in piping systems conveying flammable fluids that are in close proximity of heated surfaces the risk of ignition due to failure of the hose assembly and subsequent release of fluids is to be mitigated as far as practicable by the use of screens or other similar protection.

Flexible hoses are to be installed in clearly visible and readily accessible locations.

The installation of flexible hose assemblies is to be in accordance with the manufacturer's instructions and use limitations with particular attention to the following:

- Orientation
- End connection support (where necessary)
- Avoidance of hose contact that could cause rubbing and abrasion
- Minimum bend radii

5.7.5 Tests

5.7.5(a) *Test procedures.* Acceptance of flexible hose assemblies is subject to satisfactory type testing. Type test programs for flexible hose assemblies are to be submitted by the manufacturer and are to be sufficiently detailed to demonstrate performance in accordance with the specified standards.

The tests are, as applicable, to be carried out on different nominal diameters of hose type complete with end fittings for pressure, burst, impulse resistance and fire resistance in accordance with the requirements of the relevant standard. The following standards are to be used as applicable.

- ISO 6802 – Rubber and plastics hoses and hose assemblies with wire reinforcement – Hydraulic impulse test with flexing.
- ISO 6803 – Rubber and plastics hoses and hose assemblies – Hydraulic-pressure impulse test without flexing.
- ISO 15540 – Ships and marine technology – Fire resistance of hose assemblies – Test methods.
- ISO 15541 – Ships and marine technology – Fire resistance of hose assemblies – Requirements for test bench.
- ISO 10380 – Pipework – Corrugated metal hoses and hose assemblies.

Other standards may be accepted where agreed.

5.7.5(b) *Burst test.* All flexible hose assemblies are to be satisfactorily type burst tested to an international standard to demonstrate they are able to withstand a pressure not less than four (4) times its design pressure without indication of failure or leakage.

Note: The international standards, e.g. EN or SAE for burst testing of non-metallic hoses, require the pressure to be increased until burst without any holding period at $4 \times$ MWP.

5.7.6 Marking

Flexible hoses are to be permanently marked by the manufacturer with the following details:

- Hose manufacturer's name or trademark.
- Date of manufacture (month/year).
- Designation type reference.
- Nominal diameter.
- Pressure rating
- Temperature rating.

Where a flexible hose assembly is made up of items from different manufacturers, the components are to be clearly identified and traceable to evidence of prototype testing.

5.8 Expansion Joints

5.8.1 Molded Expansion Joints

5.8.1(a) *Molded Nonmetallic Expansion Joints.* Where molded expansion joints made of reinforced rubber or other suitable nonmetallic materials are proposed for use in Class III circulating water systems in machinery spaces, the following requirements apply:

- The expansion joint is to be oil resistant.
- The maximum allowable working pressure is not to be greater than 25% of the hydrostatic bursting pressure determined by a burst test of a prototype expansion joint. Results of the burst test are to be submitted.
- Plans of molded or built-up expansion joints over 150 mm (6 in.), including internal reinforcement arrangements, are to be submitted for approval. Such joints are to be permanently marked with the manufacturer's name and the month and year of manufacture.

5.8.1(b) *Molded Expansion Joints of Composite Construction.* Where molded expansion joints of composite construction utilizing metallic material, such as steel or stainless steel or equivalent material, with rubberized coatings inside and/or outside or similar arrangements are proposed for use in oil piping systems (fuel, lubricating or hydraulic oil), the following requirements apply:

- Expansion joint ratings for temperature, pressure, movements and selection of materials are to be suitable for the intended service.
- The maximum allowable working pressure of the system is not to be greater than 25% of the hydrostatic bursting pressure determined by a burst test of a prototype expansion joints. Results of the burst test are to be submitted.
- The expansion joints are to pass the fire resistant test specified in 4-6-2/5.7.3(c).
- The expansion joints are to be permanently marked with the manufacturer's name and the month and year of manufacture.

Molded expansion joints may be Type Approved; see 1-1-A3/1.

5.8.2 Metallic Bellow Type Expansion Joints

Metallic bellow type expansion joints may be used in all classes of piping, except that where used in Classes I and II piping, they will be considered based upon satisfactory review of the design. Detailed plans of the joint are to be submitted along with calculations and/or test results verifying the pressure and temperature rating and fatigue life.

5.9 Mechanical Joints

5.9.1 Design

These requirements are applicable to pipe unions, compression couplings and slip-on joints, as shown in 4-6-2/Table 9. The approval is to be based upon the results of testing of the actual joints in association with the following requirements. Mechanical joints similar to those indicated in 4-6-2/Table 9 and complying with these requirements will be specially considered.

5.9.1(a) *General.* The application and pressure ratings of mechanical joints are to be approved by ABS. The approval is to be based upon the testing specified in 4-6-2/5.9.2, as required for the service conditions and intended application.

5.9.1(b) *Impact on Wall Thickness.* Where the application of mechanical joints results in reduction in pipe wall thickness due to the use of bite type rings or other structural elements, this is to be taken into account in determining the minimum wall thickness of the pipe to withstand the design pressure.

5.9.1(c) *Materials.* Material of mechanical joints is to be compatible with the piping material and internal and external media.

5.9.1(d) *Burst Testing.* Mechanical joints are to be tested to a burst pressure of four (4) times the design pressure. For design pressures above 200 bar (204 kgf/cm², 2900 psi), the required burst pressure will be specially considered by ABS.

5.9.1(e) *Fire Testing.* Where appropriate, mechanical joints are to be of fire resistant type, as required by 4-6-2/Table 10.

5.9.1(f) *Locations.* Mechanical joints, which in the event of damage could cause fire or flooding, are not to be used in piping sections directly connected to the vessel's side below the bulkhead deck of passenger vessels and freeboard deck of cargo vessels or tanks containing flammable fluids.

5.9.1(g) *Joints.* The number of mechanical joints in flammable fluid systems is to be kept to a minimum. In general, flanged joints conforming to recognized standards are to be used.

5.9.1(h) *Support and Alignment.* Piping in which a mechanical joint is fitted is to be adequately adjusted, aligned and supported. Supports or hangers are not to be used to force alignment of piping at the point of connection.

5.9.1(i) *Slip-on Joints.* Slip-on joints are to be accessible for inspection. Accordingly, slip-on joints are not to be used in pipelines in cargo holds, tanks and other spaces that are not easily accessible, unless approved by ABS. Application of these joints inside tanks may be permitted only for the same media that is in the tanks.

Usage of slip type slip-on joints as the main means of pipe connection is not permitted except for cases where compensation of axial pipe deformation is necessary.

5.9.1(j) *Application.* Application of mechanical joints and their acceptable use for each service is indicated in 4-6-2/Table 10. Dependence upon the Class of piping and pipe dimensions is indicated in 4-6-2/Table 11. In particular cases, sizes in excess of those mentioned above may be accepted by ABS if in compliance with a recognized national or international standard.

5.9.1(k) *Testing.* Mechanical joints are to be tested in accordance with a program approved by ABS, which is to include at least the following:

- i) Tightness test
- ii) Vibration (fatigue) test (where necessary)
- iii) Pressure pulsation test (where necessary)
- iv) Burst pressure test
- v) Pull out test (where necessary)
- vi) Fire endurance test (where necessary)
- vii) Vacuum test (where necessary)
- viii) Repeated assembly test (where necessary)

5.9.1(l) *Joints Assembly.* The installation of mechanical joints is to be in accordance with the manufacturer's assembly instructions. Where special tools and gauges are required for installation of the joints, these are to be supplied by the manufacturer.

5.9.2 Testing of Mechanical Joints

5.9.2(a) *General.* These requirements describe the type testing for the approval of mechanical joints intended for use in marine piping systems. ABS may specify more severe testing conditions and additional tests if considered necessary to ensure the intended reliability and also accept alternative testing in accordance with national or international standards where applicable to the intended use and application. See 1-1-A3/1 for general requirements for Type Approval Certification.

5.9.2(b) *Scope.* This specification is applicable to mechanical joints defined in 4-6-2/5.9.1 including compression couplings and slip-on joints of different types for marine use.

5.9.2(c) *Documentation.* Following documents and information are to be submitted by the Manufacturer for assessment and/or approval:

- i) Product quality assurance system implemented.
- ii) Complete description of the product.
- iii) Typical sectional drawings with all dimensions necessary for evaluation of joint design.
- iv) Complete specification of materials used for all components of the assembly.
- v) Proposed test procedure as required in 4-6-2/5.9.2(e) and corresponding test reports or other previous relevant tests.
- vi) Initial information:
 - Maximum design pressures (pressure and vacuum)
 - Maximum and minimum design temperatures
 - Conveyed media
 - Intended services

- Maximum axial, lateral and angular deviation, allowed by manufacturer
- Installation details

5.9.2(d) *Materials.* The materials used for mechanical joints are to comply with the requirements of 4-6-2/5.9.1(c). The manufacturer is to submit evidence to substantiate that all components are adequately resistant to working the media at design pressure and temperature specified.

5.9.2(e) *Testing, procedures and requirements.* The aim of these tests is to demonstrate the ability of the pipe joints to operate satisfactory under intended service conditions. The scope and type of tests to be conducted e.g. applicable tests, sequence of testing, and the number of specimen, is subject to approval and will depend on joint design and its intended service in accordance with the requirements of 4-6-2/5.9.1 and 4-6-2/5.9.2, unless otherwise specified, water or oil is to be used as the test fluid.

- i) *Test program.* Testing requirements for mechanical joints are as indicated in 4-6-2/Table 12.
- ii) *Selection of Test Specimen.* Test specimens are to be selected from the production line or at random from stock. Where there is a variety of size of joints requiring approval, a minimum of three separate sizes representative of the range, from each type of joints to be tested in accordance with 4-6-2/Table 12 are to be selected.
- iii) *Mechanical Joint Assembly.* Assembly of mechanical joints should consist of components selected in accordance with 4-6-2/5.9.2(e)ii) and the pipe sizes appropriate to the design of the joints. Where pipe material would affect the performance of mechanical joints, the selection of joints for testing is to take the pipe material into consideration. Where not specified, the length of pipes to be connected by means of the joint to be tested is to be at least five times the pipe diameter. Before assembling the joint, conformity of components to the design requirements, is to be verified. In all cases the assembly of the joint shall be carried out only according to the manufacturer's instructions. No adjustment operations on the joint assembly, other than that specified by the manufacturer, are permitted during the test.
- iv) *Test Results Acceptance Criteria.* Where a mechanical joint assembly does not pass all or any part of the tests in 4-6-2/Table 12, two assemblies of the same size and type that failed are to be tested and only those tests which the mechanical joint assembly failed in the first instance, are to be repeated. In the event where one of the assemblies fails the second test, that size and type of assembly is to be considered unacceptable. The methods and results of each test are to be recorded and reproduced as and when required.
- v) *Methods of tests.*
 1. *Tightness test.* In order to ensure correct assembly and tightness of the joints, all mechanical joints are to be subjected to a tightness test, as follows.
 - a. The mechanical joint assembly test specimen is to be connected to the pipe or tubing in accordance with the requirements of 4-6-2/5.9.2(e)iii) and the manufacturer's instructions, filled with test fluid and de-aerated. Mechanical joints assemblies intended for use in rigid connections of pipe lengths, are not to be longitudinally restrained. The pressure inside the joint assembly is to be slowly increased to 1.5 times of design pressure. This test pressure is to be retained for a minimum period of 5 minutes. In the event of a drop in pressure or visible leakage, the test (including fire test) is to be repeated for two further specimens. If during the repeat test, one test piece fails, the coupling is regarded as having failed. An alternative tightness test procedures, such as a pneumatic test, may be accepted.
 - b. For compression couplings a static gas pressure test is to be carried out to demonstrate the integrity of the mechanical joints assembly for tightness under the influence of gaseous media. The pressure is to be raised to maximum pressure or 70 bar (71.4 kg/cm², 1,015 psi) whichever is less.
 - c. Where the tightness test is carried out using gaseous media as permitted in *a.* above, then the static pressure test mentioned in *b.* above need not be carried out.

2. *Vibration (Fatigue) Test.* In order to establish the capability of the mechanical joint assembly to withstand fatigue, which is likely to occur due to vibrations under service conditions, mechanical joint assemblies are to be subject to the following vibration test.

Conclusions of the vibration tests should show no leakage or damage.

a. Testing of compression couplings and pipe unions. Compression couplings and pipe unions intended for use in rigid connections of pipe are to be tested as follows. Rigid connections are joints, connecting pipe length without free angular or axial movement.

Two lengths of pipe are to be connected by means of the joint to be tested. One end of the pipe is to be rigidly fixed while the other end is to be fitted to the vibration rig. Such arrangement is shown in 4-6-2/Figure 3.

FIGURE 3
Arrangement for the Test Rig and the Joint Assembly Specimen Being Tested

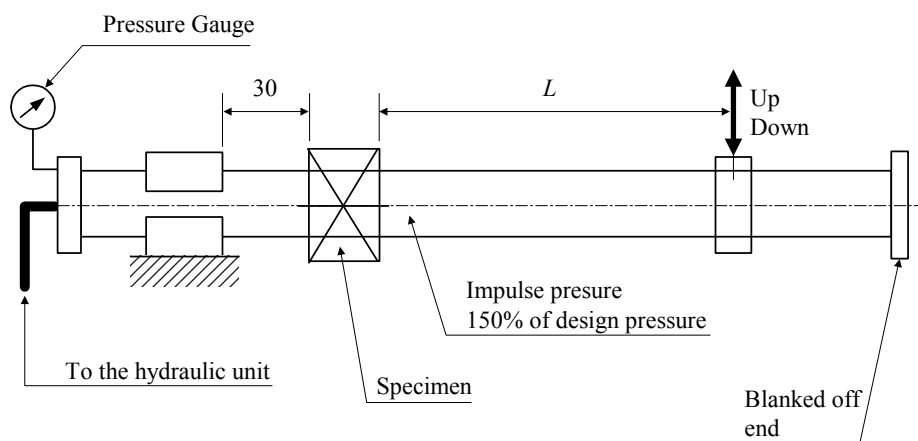

Note: Dimensions are in millimeters.

The joint assembly is to be filled with test fluid, de-aerated and pressurized to the design pressure of the joint. Pressure during the test is to be monitored. In the event of drop in the pressure and of visible leakage, the test is to be repeated as described in 4-6-2/5.9.2(e)iv). Visual examination of the joint assembly is to be carried out. Re-tightening may be accepted once during the first 1000 cycles. Vibration amplitude is to be within 5% of the value calculated from the following formula:

$$A = (2SL^2)/(3ED)$$

where

- A = single amplitude, mm (cm, in)
- L = length of the pipe, mm (cm, in)
- S = allowable bending stress, in N/mm² (kgf/cm², psi) based on 0.25 of the yield stress
- E = modulus of elasticity of tube material (for mild steel, E = 210 kN/mm², 214 × 10⁴ kgf/cm², 30 × 10⁶ psi)
- D = outside diameter of tube, mm (cm, in)

Test specimen is to withstand not less than 10⁷ cycles with frequency 20-50 Hz without leakage or damage.

- b. *Grip type and Machine grooved type joints.* Grip type joints and other similar joints containing elastic elements are to be tested in accordance with the following method. A test rig of cantilever type used for testing fatigue strength of components may be used. Such arrangement is shown in 4-6-2/Figure 4.

FIGURE 4
Arrangement for the Test Specimen Being Tested in the Test Rig

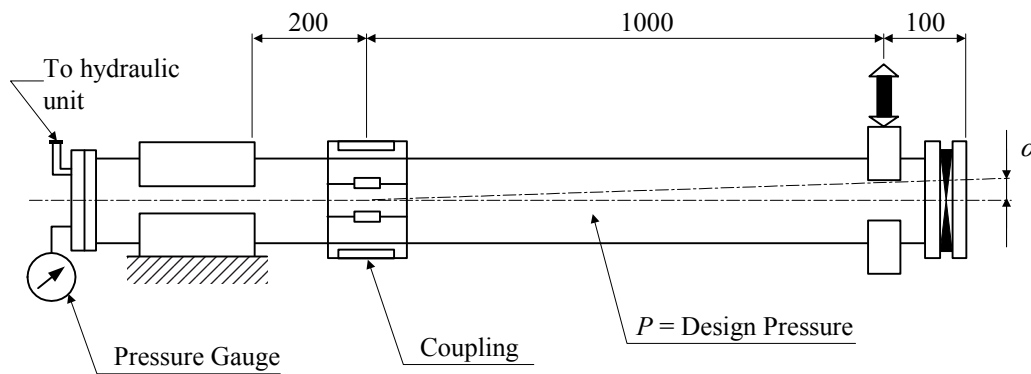

Note: Dimensions are in millimeters.

Two lengths of pipes are to be connected by means of joint assembly specimen to be tested. One end of the pipe is to be rigidly fixed while the other end is to be fitted to the vibrating element on the rig. The length of pipe connected to the fixed end should be kept as short as possible and in no case exceeds 200 mm (20 cm, 7.9 inch). Mechanical joint assemblies are not to be longitudinally restrained. The assembly is to be filled with test fluid, de-aerated and pressurized to the design pressure of the joint. Preliminary angle of deflection of pipe axis is to be equal to the maximum angle of deflection, recommended by the manufacturer. The amplitude is to be measured at 1 m (3.3 ft) distance from the centerline of the joint assembly at free pipe end connected to the rotating element of the rig. (See 4-6-2/Figure 4) Parameters of testing are to be as indicated below and to be carried out on the same assembly:

Number of Cycles	Amplitude, mm	Frequency Hz
3×10^6	± 0.06	100
3×10^6	± 0.5	45
3×10^6	± 1.5	10

Pressure during the test is to be monitored. In the event of a drop in the pressure and visual signs of leakage the test is to be repeated as described in 4-6-2/5.9.2(e)iv). Visual examination of the joint assembly is to be carried out for signs of damage which may eventually cause leakage.

3. *Pressure pulsation test.* In order to determine the capability of a mechanical joint assembly to withstand pressure pulsation likely to occur during working conditions, joint assemblies intended for use in rigid connections of pipe lengths, are to be tested in accordance with the following method. The mechanical joint test specimen for carrying out this test may be the same as that used in the test in 4-6-2/5.9.2(e)v)1(a) provided it passed that test. The vibration test in 4-6-2/5.9.2(e)v)2 and the pressure pulsation test are to be carried out simultaneously for compression couplings and pipe unions. The mechanical joint test specimen is to be connected to a pressure source capable of generating pressure pulses of magnitude as shown in 4-6-2/Figure 5.

FIGURE 5
Distribution of the Pressure Pulses Magnitude
% Design Pressure vs. Period Duration

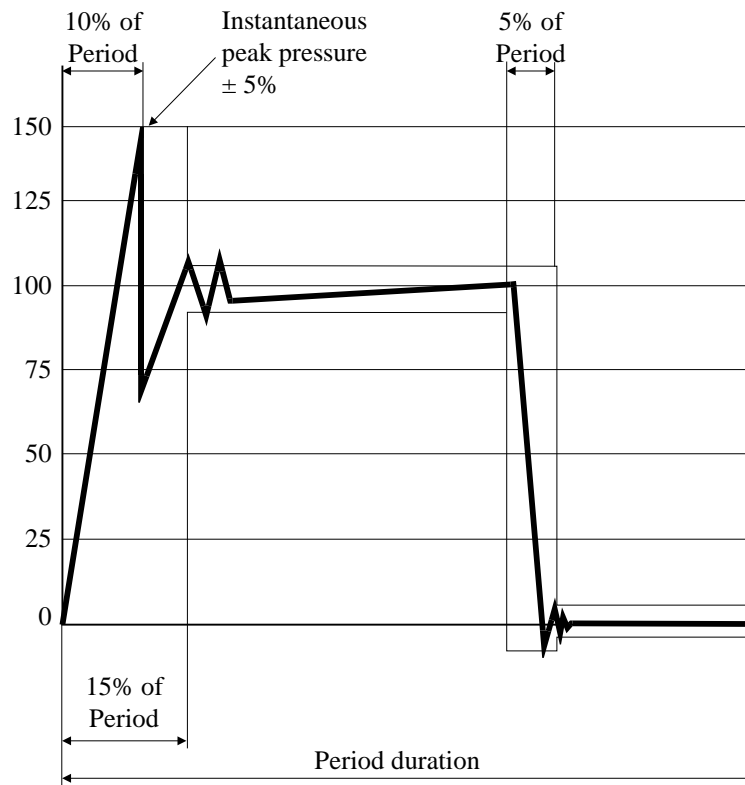

Impulse pressure is to be raised from 0 to 1.5 times the design pressure of the joint with a frequency equal to 30-100 cycles per minute. The number of cycles is not to be less than 5×10^5 cycles. The mechanical joint is to be examined visually for sign of leakage or damage during the test.

4. *Burst Pressure Test.* In order to determine the capability of the mechanical joint assembly to withstand a pressure as stated by 4-6-2/5.9.1(d), the following burst test is to be carried out. Mechanical joint test specimen is to be connected to the pipe or tubing in accordance with the requirements of 4-6-2/5.9.2(e)iii), filled with test fluid, de-aerated and pressurized to test pressure with an increasing rate of 10% per minute of test pressure. The mechanical joint assembly intended for use in rigid connections of pipe lengths is not to be longitudinally restrained. Duration of this test is not to be less than 5 minutes at the maximum pressure. Where considered convenient, the mechanical joint test specimen used in the tightness test in 4-6-2/5.9.2(e)v)1, may be used for the burst test provided it passed the tightness test. The specimen may exhibit a small deformation whilst under test pressure, but no leakage or visible cracks are permitted.
5. *Pull-out Test.* In order to determine the ability of a mechanical joint assembly to withstand the axial loading likely to be encountered in service without the connecting pipe becoming detached, following pull-out test is to be carried out. Pipes of suitable length are to be fitted to each end of the mechanical joints assembly test specimen. The test specimen is to be pressurized to design pressure. When pressure is attained, an external axial load is to be imposed with a value calculated using the following formula:

$$L = (\pi D^2/4)p$$

where

D = pipe outside diameter, mm (in.)

p = design pressure, N/mm² (kgf/mm², psi)

L = applied axial load, N (kgf, lbf)

The pressure and the axial load are to be maintained for a period of 5 minutes. During the test, pressure is to be monitored and relative movement between the joint assembly and the pipe measured. The mechanical joint assembly is to be visually examined for drop in pressure and signs of leakage or damage. There is to be no movement between the mechanical joint assembly and the connecting pipes.

6. *Fire endurance test.* In order to establish the capability of the mechanical joints to withstand the effects of fire which may be encountered in service, mechanical joints are to be subjected to a fire endurance test. The fire endurance test is to be conducted on the selected test specimens as per the following international standards.
- ISO 19921:2005(E) Ship and marine technology – Fire resistance of metallic pipe components with resilient and elastomeric seals – Test methods.
 - ISO 19922:2005(E) Ship and marine technology – Fire resistance of metallic pipe components with resilient and elastomeric seals – Requirements imposed on the test bench.

Clarification to the standard requirements:

- If the fire test is conducted with circulating water at a pressure different from the design pressure of the joint [however of at least 5 bar (5.1 kgf/cm², 72.5 psi)] the subsequent pressure test is to be carried out to twice the design pressure.
 - A selection of representative nominal bores may be tested in order to evaluate the fire resistance of a series or range of mechanical joints of the same design. When a mechanical joint of a given nominal bore (D_n) is so tested, then other mechanical joints falling in the range D_n to $2 \times D_n$ (both inclusive) are considered accepted.
 - Alternative test methods and/or test procedures considered to be at least equivalent may be accepted at the discretion of the Bureau in cases where the test pieces are too large for the test bench and cannot be completely enclosed by the flames.
 - Thermal insulation materials applied on couplings are to be non-combustible in dry condition and when subjected to oil spray. A non-combustibility test according to ISO 1182 is to be carried out.
7. *Vacuum Test.* In order to establish the capability of the mechanical joint assembly to withstand internal pressures below atmospheric, similar to the conditions likely to be encountered under service conditions, the following vacuum test is to be carried out. The mechanical joint assembly is to be connected to a vacuum pump and subjected to a pressure 170 mbar (173 mkgf/cm², 2.47 psi) absolute. Once this pressure is stabilized the specimen under test is to be isolated from the vacuum pump and the pressure is to be maintained for a period of 5 minutes. No internal pressure rise is permitted.
8. *Repeated Assembly Test.* The mechanical joint test specimen are to be dismantled and reassembled 10 times in accordance with manufacturer's instructions and then subjected to a tightness test as defined in 4-6-2/5.9.2(e)i).

5.11 Valves

5.11.1 Standard

In general, valves are to comply with a recognized national standard and are to be permanently marked in accordance with the requirements of the standard (see 4-6-1/7.1.4). For valves not complying with a recognized national standard, see 4-6-2/5.15.

5.11.2 Design Pressure

The design pressure of valves intended for use onboard a vessel is to be at least the maximum pressure to which they will be subjected but at least 3.5 bar (3.6 kgf/cm², 50 lb/in²). Valves used in open-ended systems, except those attached to side shell (see 4-6-2/9.13), may be designed for pressure below 3.5 bar. Such valves may include those in vent and drain lines, and those mounted on atmospheric tanks which are not part of the pump suction or discharge piping (e.g., level gauges, drain cocks, and valves in inert gas and vapor emission control system).

5.11.3 Construction Details

5.11.3(a) Handwheel. All valves are to close with a right hand (clockwise) motion of the handwheel when facing the end of the stem. Valves are to be either of the rising stem type or fitted with an indicator to show whether the valve is open or closed.

5.11.3(b) Bonnet. All valves of Classes I and II piping systems having nominal diameters exceeding 50 mm (2 in.) are to have bolted, pressure seal or breech lock bonnets. All valves for Classes I and II piping systems and valves intended for use in steam or oil services are to be constructed so that the stem is positively restrained from being screwed out of the body.

All cast iron valves are to have bolted bonnets or are to be of the union bonnet type. For cast iron valves of the union bonnet type, the bonnet ring is to be of steel, bronze or malleable iron.

5.11.3(c) Valve trim. Stems, discs or disc faces, seats and other wearing parts of valves are to be of corrosion resistant materials suitable for intended service. Resilient materials, where used, are subject to service limitations as specified by the manufacturers. Use of resilient materials in valves intended for fire mains (see 4-7-3/1.11.1) is to be specifically approved based on submittal of certified fire endurance tests conforming to a recognized standard.

5.11.3(d) Valve ends. All valves of Classes I and II piping systems having nominal diameters exceeding 50 mm (2 in.) are to have flanged or welded ends. Welded ends are to be butt welding type, except that socket welding ends may be used for valves having nominal diameters of 80 mm (3 in.) or less (see 4-6-2/5.5.2).

5.11.4 Manufacturer's Guarantee

The manufacturer of a valve is to guarantee that the valve is constructed to the standard and conforming to the identifications to which it is marked. The manufacturer is to guarantee also that the valve has been tested before shipment to the pressure required by the pressure rating of the valve. The certificate of test is to be submitted upon request.

5.13 Safety Relief Valves

Safety relief valves are to be treated as valves for the purposes of these Rules and are to be constructed of materials permitted for the piping system classes and services in which they are installed. In general, they are also to comply with a recognized standard for relieving capacity.

5.15 Nonstandard Components

Components not manufactured to a recognized national standard are preferably to be Type Approved (see 1-1-A3/5). They may be considered for acceptance based on manufacturers' specified pressure and temperature ratings and on presenting evidence, such as design calculations or type test data, that they are suitable for the intended purpose. For Classes I and II piping applications, drawings showing details of construction, materials, welding procedures, etc., as applicable, are to be submitted for such components, along with the basis for the pressure and temperature ratings.

5.17 Type Approval Program

The Type Approval Program (as described in Appendix 1-1-A3) may be applied to design evaluation and approval of piping components in 4-6-2/5.5 through 4-6-2/5.15. Each product approved under this program need not be subjected to further design review or a prototype test, or both, each time the product is proposed for use. The list of approved products will be posted on the ABS website, <http://www.eagle.org/typeapproval>.

7 Fabrication and Tests

7.1 Welded Fabrication

Requirements for welding of pipes and fittings, heat treatment and nondestructive testing are given in Section 2-4-4. For the purpose of radiography, see 2-4-4/11.3.1.

7.3 Hydrostatic Tests

7.3.1 Hydrostatic Test of Pipes Before Installation Onboard

All Classes I and II pipes and integral fittings after completion of shop fabrication, but before insulation and coating, are to be hydrostatically tested in the presence of a Surveyor, preferably before installation, at the following pressure.

$$P_H = 1.5P$$

where P_H = test pressure, and P = design pressure.

Class III steam, boiler feed, compressed air and fuel oil pipes and their integral fittings, where the design pressure is greater than 3.5 bar (3.6 kgf/cm², 50 psi), are to be hydrostatically tested to the test pressure p_H , as defined above.

Small bore pipes and tubes of less than 15 mm outside diameter may be exempted from the required hydrostatic test, depending on the intended application.

For steel pipes and integral fittings where the design temperature is above 300°C (572°F), the test pressure is to be determined by the following formula, but need not exceed $2P$. The test pressure may be reduced, however, to avoid excessive stress in way of bends to $1.5P$. In no case is the membrane stress to exceed 90% of the yield stress at the test temperature.

$$P_H = 1.5P \frac{S_{100}}{S_T}$$

where S_{100} = permissible stress at 100°C (212°F), and S_T = permissible stress at design temperature.

Where it is not possible to carry out the required hydrostatic tests for all segments of pipes and integral fittings before installation, the remaining segments, including the closing seams, may be so tested after installation. Or, where it is intended to carry out all of the required hydrostatic tests after installation, such tests may be conducted in conjunction with those required in 4-6-2/7.3.3. In both of these cases, testing procedures are to be submitted to the Surveyor for acceptance.

7.3.2 Hydrostatic Tests of Shell Valves (1 July 2018)

All valves intended for installation on the side shell at or below the deepest load waterline, including those at the sea chests, are to be hydrostatically tested in the presence of the Surveyor, before installation.

The valve housing of each valve is to be subjected to a pressure of not to be less than test pressure of 5 bar (5.1 kgf/cm², 72.5 psi). No leakage is permitted and holding time as follows:

- 15 seconds for sizes up to 50 mm (2 inch)
- 60 seconds for sizes 75 mm - 150 mm (2.5 inch - 6 inch)
- 120 seconds for sizes 200 mm - 300 mm (8 inch - 12 inch)
- 300 seconds for sizes 350 mm (14 inch) and larger

The valve assembly is to be subjected to a hydrostatic seat leakage test. The test is to be performed with closed valve with the other end open to atmosphere. The pressure is to be applied independently on each side. Test pressure is not to be less than 5 bar (5.1 kgf/cm², 72.5 psi). Holding time is 5 minutes for all sizes.

7.3.3 Tests After Installation

7.3.3(a) General. All piping systems are to be tested in the presence of the Surveyor under working conditions after installation and checked for leakage. Where necessary, other techniques of tightness test in lieu of a working pressure test may be considered.

7.3.3(b) Specific Systems. The following piping systems are to be hydrostatically tested in the presence of the Surveyor after installation to $1.5P$, but not less than 4 bar (4.1 kgf/cm², 58 psi).

- Gas and liquid fuel systems
- Heating coils in tanks

For cargo oil, liquefied gas, and chemical cargo and associated piping, see 5C-1-7/3.3.5, 5C-8-5/13.2.2 and 5C-9-5/4.2 respectively.

7.3.4 Pneumatic Tests in Lieu of Hydrostatic Tests

In general, pneumatic tests in lieu of hydrostatic test are not permitted. Where it is impractical to carry out the required hydrostatic tests, pneumatic tests may be considered. In such cases, the procedure for carrying out the pneumatic test, having regard to safety of personnel, is to be submitted to the applicable ABS [Assistant Chief Surveyor](#) for special consideration.

7.5 Resistance Testing

Piping required by 4-6-2/9.15 to be electrically earthed (grounded) to the hull are to be checked in the presence of the Surveyor to ensure that the resistance from any point along the piping to the hull does not exceed 1 MΩ. Where bonding straps are used, they are to be located in visible locations.

9 Installation Details

9.1 Protection from Mechanical Damage

All piping located in a position where it is liable to mechanical damage is to be protected. The protective arrangements are to be capable of being removed to enable inspection.

9.3 Protection of Electrical Equipment

The routing of pipes in the vicinity of switchboards and other electrical equipment is to be avoided as far as possible. When such a routing is necessary, care is to be taken to ensure that no flanges or joints are installed over or near the equipment unless provisions are made to prevent any leakage from damaging the equipment or creating a hazard for personnel.

9.5 Provisions for Expansion and Contraction of Piping

Provisions are to be made to take care of expansion and contraction of piping due to temperature and pressure variations as well as working of the hull. Suitable provisions include, but are not limited to, piping bends, elbows, offsets and changes in direction of the pipe routing or expansion joints.

Where expansion joints are used, the following requirements apply:

- Pipe support.* Adjoining pipes are to be suitably supported so that the expansion joints do not carry any significant pipe weight.
- Alignment.* Expansion joints are not to be used to make up for piping misalignment errors. Misalignment of an expansion joint reduces the rated movements and can induce severe stresses into the joint material, thus causing reduced service life. Alignment is to be within tolerances specified by the expansion joint manufacturer.
- Anchoring.* Expansion joints are to be installed as close as possible to an anchor point. Where an anchoring system is not used, control rods may be installed on the expansion joint to prevent excessive movements from occurring due to pressure thrust of the line.
- Mechanical damage.* Where necessary, expansion joints are to be protected against mechanical damage.

- v) *Accessible location.* Expansion joints are to be installed in accessible locations to permit regular inspection and/or periodic servicing.
- vi) *Mating flange.* Mating flanges are to be clean and usually of the flat faced type. When attaching beaded end flange expansion joints to raised face flanges, the use of a ring gasket is permitted. Rubber expansion joints with beaded end flange are not to be installed next to wafer type check or butterfly valves. Serious damage to the rubber flange bead can result due to lack of flange surface and/or bolt connection.

9.6 Mechanical Joints

The installation of mechanical pipe joints, as covered by 4-6-2/5.5.5 and 4-6-2/5.9, is to be in accordance with the manufacturer's assembly instructions. Where special tools and gauges are required for installation of the joints, these are to be specified and supplied as necessary by the manufacturer. These special tools are to be kept onboard.

9.7 Piping Penetrations Through Bulkheads, Decks and Tank Tops

9.7.1 Watertight Integrity

Where it is necessary for pipes to penetrate watertight bulkheads, decks or tank tops, the penetrations are to be made by methods which will maintain the watertight integrity. For this purpose, bolted connections are to have bolts threaded into the plating from one side; through bolts are not to be used. Welded connections are either to be welded on both sides or to have full penetration welds from one side.

9.7.2 Fire Tight Integrity

Where pipes penetrate bulkheads, decks or tank-tops which are required to be fire tight or smoke tight, the penetrations are to be made by approved methods which will maintain the same degree of fire tight or smoke tight integrity.

9.7.3 Collision Bulkhead Penetrations

9.7.3(a) Allowed Penetrations. A collision bulkhead may be penetrated only as follows.

- i) Except as provided in 4-6-2/9.7.3(a)ii), the collision bulkhead may be pierced below the bulkhead deck by not more than one pipe for dealing with fluid in the forepeak tank, provided that the pipe is fitted with a screwdown or butterfly valve capable of being operated from above the bulkhead deck; the valve chest being secured to the collision bulkhead inside the forepeak. The valve is to have open/closed indicators locally and above the bulkhead deck.
- ii) If the forepeak is divided to hold two kinds of liquids, the collision bulkhead may be pierced below the margin line by two pipes, each of which is fitted as required by 4-6-2/9.7.3(a)i), provided there is no practical alternative to the fitting of such a second pipe and that, having regard to the additional subdivision provided in the forepeak, the safety of the vessel is maintained.
- iii) The valve in 4-6-2/9.7.3(a)i) may be fitted of on the after side of the collision bulkhead provided that the valve is readily accessible under all service conditions and the space in which they are located is not a cargo space. Local operation of the valve is acceptable.

9.7.3(b) Valve Details. Piping penetrating collision bulkheads is to comply with the following requirements:

- i) Gray cast iron valves are not acceptable. The use of nodular iron valve is acceptable, see 4-6-2/3.1.4.
- ii) No valves or cocks for sluicing (draining) are to be fitted on a collision bulkhead.

9.7.4 Valve in Watertight Bulkhead for Sluicing Purposes

Where valves are fitted directly onto watertight bulkheads without piping on either side for sluicing, drainage or liquid transfer, the valves are to be readily accessible at all times and are to be operable (open and close) from a position above the bulkhead deck. Indicators are to be provided to show whether the valves are open or closed.

9.9 Protection from Overpressure

9.9.1 General

Each piping system or part of a system which may be exposed to a pressure greater than that for which it is designed is to be protected from overpressurization by a relief valve. Other protective devices, such as bursting discs, may be considered for some systems.

9.9.2 System Pressurized by Centrifugal Pumps

Where systems are served only by centrifugal pumps such that the pressure delivered by the pump cannot exceed the design pressure of the piping, relief valves are not necessary.

9.9.3 Relief Valve Discharges

For systems conveying flammable liquids or gases, relief valves are to be arranged to discharge back to the suction side of the pump or to a tank. The relief valve of a CO₂ system is to discharge outside of the CO₂ container storage compartment. In all cases, when discharging directly to the atmosphere, the discharge is not to impinge on other piping or equipment and is to be directed away from areas used by personnel.

9.9.4 Setting

Relief valves are to be set at pressures not exceeding the piping design pressure. For hydraulic systems, see 4-6-7/3.7.2; for steering gear hydraulic piping systems, see 4-3-4/9.1.6.

9.9.5 Pressure Vessels Associated with Piping System

A pressure vessel, which can be isolated from piping system relief valves, is to have another relief valve fitted either directly on the pressure vessel or between the pressure vessel and the isolation valve.

9.11 Temperature and Pressure Sensing Devices

9.11.1 Temperature

Where thermometers or other temperature sensing devices are fitted in piping systems, thermometer wells are to be used so that the devices can be removed without impairing the integrity of the pressurized system.

9.11.2 Pressure

Where pressure gauges or other pressure sensing devices are fitted in piping systems, valves are to be provided so that the devices can be isolated and removed without impairing the integrity of the pressurized system.

9.11.3 Tanks

Pressure, temperature and level sensing devices installed on tanks at locations where they are subjected to a static head of liquid are to be fitted with valves or arranged such that they may be removed without emptying the tank.

9.13 Shell Connections

9.13.1 General

Positive closing valves are to be fitted at the shell at inlets (including sea chests) and discharges. Discharges from scuppers and drains are to be fitted with valves as required by 4-6-4/3.3. Where it is impractical to install the valve directly at the shell, a distance piece can be provided. Materials readily rendered ineffective by heat are not to be used for connection to the shell where the failure of the material in the event of a fire would give rise to danger of flooding. Discharges at the shell are to be so located as to prevent any discharge from falling onto a lowered lifeboat or rescue boat.

9.13.2 Valves

Shell valves are to comply with the following requirements:

- i)* Gray cast iron valves are not to be used as shell valves. Nodular iron valves are acceptable, see 4-6-2/3.1.4.
- ii)* Shell valves are to be installed such that the inboard piping can be removed and the valve can remain in place without impairing the watertight integrity. Wafer-type butterfly valves are not acceptable. Butterfly valves with lugs, however, may be accepted.
- iii)* Controls for positive closing valves are to be readily accessible and controllable from the floors or gratings. Open or closed indicators are to be provided, see 4-6-2/5.11.3(a).
- iv)* Power-operated valves are to be arranged for manual operation in the event of a failure of the power supply.
- v)* For hydrostatic tests, see 4-6-2/7.3.2.

9.13.3 Connection Details

Where the valve is connected directly to the shell, studs can be used if a reinforcing ring of substantial thickness (a heavy pad) is welded to the inside of the shell. In this case, the studs are to be threaded into the reinforcing ring and are not to penetrate the shell.

Where a distance piece is fitted between the shell and the shell valves, the pipe is to be of steel and of wall thickness not less than that specified in 4-6-4/3.3.5(a).

In general, the pipe is to be as short as possible. The pipe is to extend through the shell plating and is to be welded on both sides or with full strength welds from one side. Consideration is to be given to supporting the pipe to the surrounding structure.

Where an inlet or discharge is to pass through a wing tank or a cargo hold, the valve may be installed on the inner bulkhead or similar location provided that the pipe between the valve and the shell is of wall thickness not less than as specified above, with all joints welded and with built-in provision for flexibility. Such pipes, where located in a cargo hold, are to have protection from mechanical damage.

Threaded connections are not considered an acceptable method of connection outboard of the shell valves.

9.13.4 Boiler Blow-off

Boiler and evaporator blow-off overboard discharges are to have doubling plates or heavy inserts fitted. The pipe is to extend through the doubling and the shell.

9.13.5 Sea Chests

Sea chests are to comply with the following requirements:

- i)* Located in positions where the possibility of blanking off the suction is minimized;
- ii)* Fitted with strainer plates through which the clear area is to be at least 1.5 times the area of the inlet valves;
- iii)* Means are provided for clearing the strainer plates, such as by using compressed air or low pressure steam;
- iv)* Additional requirements for sea chests on ice strengthened vessels in 6-1-3/17, 6-1-4/19.13, 6-1-5/45.13, and 6-1-6/29.3 are to be complied with, where applicable.

9.15 Control of Static Electricity

In order to prevent dangerous build-up of static charges resulting from the flow of fluid in piping, the following items are to be earthed (grounded) to the hull such that the resistance between any point on the piping and the hull (across joints, pipe to hull) does not exceed 1 MΩ:

- Piping and independent tanks containing fluids having flash point of 60°C (140°F) or less.
- Piping that is routed through hazardous areas.

This can be achieved if the items are directly, or via their supports, either welded or bolted to the hull. Bonding straps are required for items not permanently connected to the hull, for example:

- Independent cargo tanks
- Piping which is electrically insulated from the hull
- Piping which has spool pieces arranged for removal
- Wafer-style valves with non-conductive (e.g., polytetrafluoroethylene PTFE) gaskets or seals

Bonding straps are to be:

- Installed in visible locations
- Protected from mechanical damage
- Made of corrosion-resistant material

This requirement does not apply to tank containers.

9.17 Accessibility of Valves

Where the valves are required by the Rules to be readily accessible, their controls, during normal operating conditions, are to be:

- i) Located in a space normally entered without using tools;
- ii) Clear of or protected from obstructions, moving equipment and hot surfaces that prevent operation or servicing; and
- iii) Within operator's reach.

For propulsion machinery spaces intended for centralized or unattended operations (**ACC/ACCU/ABCU** notation), the location of the controls of any valve serving a sea inlet, a discharge below the waterline or an emergency bilge system [see also 4-6-4/5.5.5(c)] is to be such as to allow adequate time for operation in case of influx of water to the space, having regard to the time likely to be required in order to reach and operate such controls. If the level to which the space could become flooded with the ship in the fully loaded condition so requires, arrangements are to be made to operate the controls from a position above such level.

9.19 Common Overboard Discharge

In general, various types of systems which discharge overboard are not to be interconnected without special approval; that is, closed pumping systems, deck scuppers, solid lines or sanitary drains are not to have a common overboard discharge.

TABLE 1
Allowable Stress Values S for Steel Pipes; N/mm² (kgf/mm², psi) (see 4-6-2/5.1.2)

Material ABS Gr. ASTM Gr. Nominal Composition	Tensile Strength N/mm ² kgf/mm ² psi	Service Temperature									
		-29°C (-20°F) to 344°C (650°F)	372°C 700°F	399°C 750°F	427°C 800°F	455°C 850°F	483°C 900°F	510°C 950°F	538°C 1000°F	566°C 1050°F	593°C 1100°F
<i>M</i>		0.8	0.8	0.8	0.8	0.8	0.8	1.0	1.4	1.4	1.4
Gr.1 A53-FBW	310 31.5 45000	46.9 4.78 6800	46.6 4.75 6500								
Gr. 2 A53-A, ERW C, Mn	330 33.7 48000	70.3 7.17 10200	68.3 6.96 9900	62.8 6.40 9100	53.1 5.41 7700						
Gr.2 A53-A, SML C, Mn	330 33.7 48000	82.8 8.44 12000	80.6 8.22 11700	73.7 7.52 10700	62.1 6.33 9000						
Gr.3 A53-B, ERW C, Mn	415 42 60000)	88.3 9.0 12800	84.1 8.58 12200	75.8 7.73 11000	63.4 6.47 9200						
Gr.3 A53-B, SML C, Mn	415 42 60000	103.5 10.55 15000	99.2 10.12 14400	89.6 9.14 13000	74.4 7.59 10800						
Gr.4 A106-A C, Mn, Si	330 33.7 48000	82.8 8.44 12000	80.7 8.23 11700	73.7 7.52 10700	62.1 6.33 9000						
Gr.5 A106-B C, Mn, Si	415 42 60000	103.5 10.55 15000	99.2 10.12 14400	89.6 9.14 13000	74.4 7.59 10800						
Gr.6 A355-P1 1/2 Mo	380 39 55000	95.1 9.70 13800	95.1 9.70 13800	95.1 9.70 13800	93.1 9.49 13500	90.3 9.21 13100					
Gr. 7 A335-P2 1/2 Cr 1/2 Mo	380 39 55000	95.1 9.70 13800	95.1 9.70 13800	95.1 9.70 13800	93.1 9.49 13500	90.3 9.21 13100	88.3 9.0 12800	63.4 6.47 9200	40.7 4.15 5900		
Gr. 8 A135-A	330 33.7 48000	70.3 7.17 10200	68.3 6.96 9900	62.8 6.40 9100	53.1 5.41 7700						
Gr. 9 A135-B	415 42 60000	88.3 9.0 12800	84.1 8.58 12200	75.8 7.73 11000	63.4 6.47 9200						
Gr.11 A335-P11 1-1/4 Cr 1/2 Mo	415 42 60000	103.5 10.55 15000	103.5 10.55 15000	103.5 10.55 15000	103.5 10.55 15000	99.2 10.12 14400	90.3 9.21 13100	75.8 7.73 11000	45.4 4.64 6600	28.2 2.88 4100	20.7 2.11 3000
Gr. 12 A335-P12 1 Cr 1/2 Mo	415 42 60000	103.5 10.55 15000	103.5 10.55 15000	103.5 10.55 15000	101.7 10.37 14750	91.9 9.98 14200	90.3 9.21 13100	75.8 7.73 11000	45.5 4.64 6600	28.2 2.88 4100	19.3 1.97 2800
Gr. 13 A335-P22 2-1/4 Cr 1 Mo	415 42 60000	103.5 10.55 15000	103.5 10.55 15000	103.5 10.55 15000	103.5 10.55 15000	99.2 10.12 14400	90.3 9.21 13100	75.8 7.73 11000	53.7 5.48 7800	35.9 3.66 5200	28.9 2.95 4200

Notes

- Intermediate values of S and M may be determined by interpolation.
- For grades of pipe other than those given in this Table, S values may be obtained from ANSI/ASME B31.1 *Code for Pressure Piping*.
- Consideration to be given to the possibility of graphite formation in the following steels: Carbon steel above 425°C (800°F); carbon-molybdenum steel above 468°C (875°F); chrome-molybdenum steel (with chromium under 0.60%) above 524°C (975°F).

TABLE 2
Allowable Stress S for Copper and Copper Alloy Pipes (see 4-6-2/5.1.1)

Material	Minimum Tensile Strength	Allowable Stress S , N/mm ² , kgf/mm ² , psi										
		50°C 122°F	75°C 167°F	100°C 212°F	125°C 257°F	150°C 302°F	175°C 347°F	200°C 392°F	225°C 437°F	250°C 482°F	275°C 527°F	300°C 572°F
Copper	215	41	41	40	40	34	27.5	18.5				
	22	4.2	4.2	4.1	4.1	3.5	2.8	1.9				
	31200	5950	5950	5800	5800	4930	3990	2680				
Brass	325	78	78	78	78	78	51	24.5				
	33	8.0	8.0	8.0	8.0	8.0	5.2	2.5				
	47100	11310	11310	11310	11310	11310	7395	3550				
Copper nickel (with less than 10% nickel)	275	68	68	67	65.5	64	62	59	56	52	48	44
	28	6.9	6.9	6.8	6.7	6.5	6.3	6.0	5.7	5.3	4.9	4.5
	39900	9860	9860	9715	9500	9280	8990	8555	8120	7540	6960	6380
Copper nickel (with 10% or more nickel)	365	81	79	77	75	73	71	69	67	65.5	64	62
	37.2	8.3	8.1	7.8	7.6	7.4	7.2	7.0	6.8	6.7	6.5	6.3
	52900	11745	11455	11165	10875	10585	10295	10005	9715	9500	9280	8990

Notes

- Intermediate values are to be determined by interpolation
- Materials not listed in this table can be used upon approval of the permissible stress

TABLE 3
Corrosion Allowance c for Steel Pipes (see 4-6-2/5.1.1)

Piping Service	Corrosion Allowance, c	
	mm	in.
Superheated steam	0.3	0.012
Saturated steam	0.8	0.032
Steam heating coils in cargo tanks	2.0	0.079
Feed water for boilers in open circuits	1.5	0.059
Feed water for boilers in closed circuits	0.5	0.02
Blowdown for boilers	1.5	0.059
Compressed air	1.0	0.039
Hydraulic oil	0.3	0.012
Lubricating oil	0.3	0.012
Fuel oil	1.0	0.039
Cargo oil	2.0	0.079
Refrigerant	0.3	0.012
Fresh water	0.8	0.032
Sea water	3.0	0.118

Notes

- The corrosion allowance may be reduced by 50% where pipes and any integral joints are protected against corrosion by means of coating, lining, etc.
- For pipes passing through tanks, the proper additional corrosion allowance is to be taken into account for the external medium.
- For special alloy steels which are considered to be corrosion resistant, the corrosion allowance can be reduced to zero.

TABLE 4
Minimum Wall Thickness for Steel Pipes (See 4-6-2/5.1.3)

Nom. Size mm	Outside Dia. mm	Wall Thickness, mm				
		A	B	C	D	E
6	10.2	1.6				
8	13.5	1.8				
10	17.2	1.8				
15	21.3	2.0	2.8			
20	26.9	2.0	2.8			
25	33.7	2.0	3.2	4.2	6.3	6.3
32	42.4	2.3	3.5	4.2	6.3	6.3
40	48.3	2.3	3.5	4.2	6.3	6.3
50	60.3	2.3	3.8	4.2	6.3	6.3
65	76.1	2.6	4.2	4.2	6.3	7.0
80	88.9	2.9	4.2	4.2	7.1	7.6
90	101.6	2.9	4.5	4.5	7.1	8.1
100	114.3	3.2	4.5	4.5	8.0	8.6
125	139.7	3.6	4.5	4.5	8.0	9.5
150	168.3	4.0	4.5	4.5	8.8	11.0
200	219.1	4.5	5.8	5.8	8.8	12.5
250	273.0	5.0	6.3	6.3	8.8	12.5
300	323.9	5.6	6.3	6.3	8.8	12.5
350	355.6	5.6	6.3	6.3	8.8	12.5
400	406.4	6.3	6.3	6.3	8.8	12.5
450	457.0	6.3	6.3	6.3	8.8	12.5

Nom. Size in.	Outside Dia. in.	Wall Thickness, in.				
		A	B	C	D	E
1/8	0.405	0.063				
1/4	0.540	0.071				
3/8	0.675	0.071				
1/2	0.840	0.079	0.110			
3/4	1.050	0.079	0.110			
1	1.315	0.079	0.126	0.165	0.248	0.248
1 1/4	1.660	0.091	0.138	0.165	0.248	0.248
1 1/2	1.900	0.091	0.138	0.165	0.248	0.248
2	2.375	0.091	0.150	0.165	0.248	0.248
2 1/2	2.875	0.102	0.165	0.165	0.248	0.276
3	3.500	0.114	0.165	0.165	0.280	0.300
3 1/2	4.000	0.114	0.177	0.177	0.315	0.318
4	4.500	0.126	0.177	0.177	0.315	0.337
5	5.563	0.142	0.177	0.177	0.346	0.375
6	6.625	0.157	0.177	0.177	0.346	0.432
8	8.625	0.177	0.228	0.228	0.346	0.5
10	10.750	0.197	0.248	0.248	0.346	0.5
12	12.750	0.220	0.248	0.248	0.346	0.5
14	14.000	0.220	0.248	0.248	0.346	0.5
16	16.000	0.248	0.248	0.248	0.346	0.5
18	18.000	0.248	0.248	0.248	0.346	0.5

Columns:

- A Pipes in general, except where Columns B, C, D or E are applicable
- B Bilge, ballast and sea water pipes except those covered by column D.
- C Vent, overflow and sounding pipes for integral tanks except those covered by column D (see Notes 6 and 7) and fuel oil pipes passing through fuel oil tanks.
- D Bilge, ballast, vent, overflow and sounding pipes passing through fuel tanks (see Notes 6, 7 and 8).
Bilge, vent, overflow, sounding and fuel pipes passing through ballast tanks (see Notes 6, 7 and 8).
- E Ballast pipes passing through cargo oil tanks (see Note 9).
Cargo pipes passing through ballast tanks (see Note 9).

Notes:

- 1 The minimum thicknesses are the smallest thicknesses selected from those thicknesses specified in ISO 4200 Series 1, JIS, or ASTM Standards. Notwithstanding the requirements of this Table, diameters and thicknesses specified in other recognized standards will also be acceptable.
- 2 For threaded pipes, where approved, the thickness is to be measured to the bottom of the thread.
- 3 For pipes protected against corrosion, a reduction of thickness not exceeding 1 mm (0.039 in.) may be considered.
- 4 For minimum wall thicknesses of copper, copper alloy and austenitic stainless steel pipes, see 4-6-2/Table 5A and 4-6-2/Table 5B.
- 5 This table is not applicable to exhaust gas pipes.
- 6 For that part of a vent pipe exposed to weather, pipe wall is to be as specified in 4-6-4/9.3.2(a).
- 7 The thickness indicated for sounding pipes is for the portions outside the tanks to which the pipe is opened. Within bilge well, to which the pipe is not opened, the thickness is to be extra-heavy; see 4-6-4/11.3.3iv).
- 8 For bilge pipes, column D thickness applies only where required by 4-6-4/5.5.4(c).
- 9 Where permitted by 5C-1-7/3.3.3 and 5C-1-7/5.3.2.
- 10 For nominal sizes larger than 450 mm (18 in.), the minimum wall thickness specified for 450 mm (18 in.) nominal size pipe is applicable.

TABLE 5A
Minimum Wall Thickness for Copper and Copper Alloy Pipes (see 4-6-2/5.1.3)

<i>Outside Diameter</i>		<i>Minimum Wall Thickness</i>			
		<i>Copper</i>		<i>Copper Alloy</i>	
<i>mm</i>	<i>in.</i>	<i>mm</i>	<i>in.</i>	<i>mm</i>	<i>in.</i>
8 – 10	0.30 – 0.40	1.0	0.039	0.8	0.031
12 – 20	0.475 – 0.80	1.2	0.047	1.0	0.039
25 – 44.5	1.00 – 1.75	1.5	0.059	1.2	0.047
50 – 76.1	2.00 – 3.00	2.0	0.079	1.5	0.059
88.9 – 108	3.50 – 4.25	2.5	0.098	2.0	0.079
133 – 159	5.25 – 6.25	3.0	0.118	2.5	0.098
193.7 – 267	7.625 – 10.50	3.5	0.138	3.0	0.118
273 – 457.2	10.75 – 18.00	4.0	0.157	3.5	0.138
470	18.50	4.0	0.157	3.5	0.138
508	20.00	4.5	0.177	4.0	0.157

Note: The above minimum thicknesses are taken from those thicknesses available in ISO Standards. Diameter and thickness according to other recognized standards will be accepted.

TABLE 5B
Minimum Wall Thickness for Austenitic Stainless Steel Pipes, (see 4-6-2/5.1.3)

<i>External Diameter</i>		<i>Minimum Wall Thickness</i>	
<i>mm</i>	<i>in.</i>	<i>mm</i>	<i>in.</i>
10.2 – 17.2	0.40 – 0.68	1.0	0.039
21.3 – 48.3	0.84 – 1.90	1.6	0.063
60.3 – 88.9	2.37 – 3.50	2.0	0.079
114.3 – 168.3	4.50 – 6.63	2.3	0.091
219.1	8.63	2.6	0.102
273.0	10.75	2.9	0.114
323.9 – 406.4	12.75 – 16.00	3.6	0.142
Over 406.4	Over 16.00	4.0	0.157

Note: Diameters and thicknesses according to national or international standards may be accepted.

TABLE 6
Typical Flange Types (see 4-6-2/5.5.4)

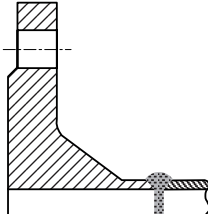
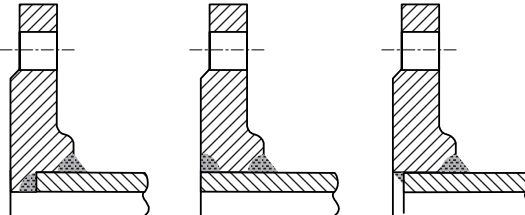
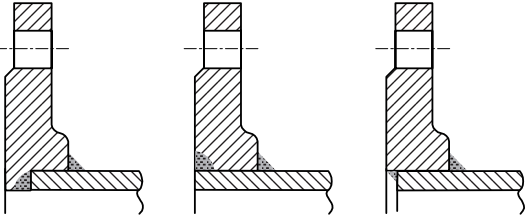
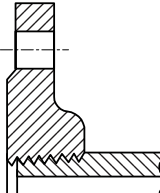
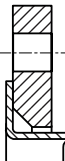
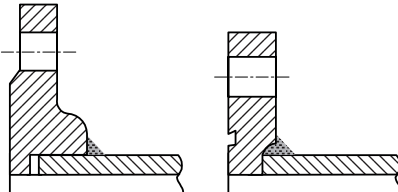
<i>Flange Type</i>	<i>Typical Configuration</i>
Type A Weld neck flange, raised face or flat face with ring type gasket.	
Type B Slip-on welded hub (or without hub) flange; attached to pipe with at least a groove weld deposited from the back of the flange and a fillet weld or equivalent on the other side; raised face or flat face with ring type gasket.	
Type C Slip-on welded hub (or without hub) flange; attached to pipe with double fillet welds or equivalent; raised face or flat face with ring type gasket.	 <p>(Must be with hub)</p>
Type D Threaded hub flange; attached to pipe by tapered threads; some designs require the pipe be expanded, or the threaded ends be seal-welded; raised face or flat face with ring type gasket.	
Type E Unattached flange; no attachment to pipe.	
Type G Socket-welded flange; attached to pipe by single fillet weld, with or without groove weld, deposited from one side of the flange only; raised face (with gasket) or flat face (with o-ring).	

Notes:

- 1 “Integral” flanges are designs where the flange is cast or forged integrally with the pipe wall, or otherwise welded in such a manner that the flange and the pipe wall are considered to be the equivalent of an integral structure.
- 2 “Loose” flanges are designs where the method of attachment of the flange to the pipe is not considered to give the mechanical strength equivalent of an integral flange, or in which the flange has no direct connection to the pipe wall. Slip-on welded flange attached to pipe with fillet welds only is generally considered a loose flange.

TABLE 7
Limitation of Use for Typical Flange Types (see 4-6-2/5.5.4)

<i>Flange Type</i>	<i>Class of Piping</i>	<i>Limitations</i>
A	I, II, III	None
B	I, II, III	Pressure/temperature rating ≤ ASME B16.5 Class 300 or equivalent recognized national standard. For steam piping additionally limited to pipe sizes $d \leq$ NPS 100 mm (4 in.) Slip-on flanges for higher ratings, which comply with ASME or other recognized standards, will be subject to special consideration. [Ref. 2-4-2/9.5.3, 2-4-4/5.7 and 2-4-4/17.5]
C	I, II, III	Same as for type B above.
D	II, III	Not for toxic fluid, corrosive fluid, volatile flammable liquid ⁽¹⁾ , liquefied gas, fuel oil, lubricating oil, thermal oil and flammable hydraulic oil. For other services as per limitations for type B above.
E	II, III	Not for toxic fluid, corrosive fluid, volatile flammable liquid ⁽¹⁾ , liquefied gas, fuel oil, lubricating oil, thermal oil, flammable hydraulic oil and steam systems. For water and open-ended lines. For other services, see 4-6-2/5.15.
G	I, II, III	Pressure/temperature rating ≤ ASME B16.5 Class 600 and NPS ≤ 80 mm (3 in.), or equivalent recognized national standard. Pressure/temperature rating ≤ ASME B16.5 Class 1500 and NPS ≤ 65 mm (2.5 in.), or equivalent recognized national standard Not to be used in steering gear and controllable pitch propeller systems. [Ref. 2-4-4/5.7 and 2-4-4/17.5]

Note:

- 1 Volatile flammable liquid is a flammable liquid heated to above its flash point, or a flammable liquid having a flash point at or below 60°C (140°F) other than cargo oil.

TABLE 8
Commercial Pipe Sizes and Wall Thicknesses

Nominal Pipe Size	Outside Diameter (in., mm)	Nominal Wall Thickness (in., mm)					
		Standard	Sch.40	Extra Strong	Sch.80	Sch.160	Double Extra Strong
1/8 in. 6 mm	0.405 10.287	0.068 1.727	0.068 1.727	0.095 2.413	0.095 2.413	--	--
1/4 in. 8 mm	0.540 13.716	0.088 2.235	0.088 2.235	0.119 3.023	0.119 3.023	--	--
3/8 in. 10 mm	0.675 17.145	0.091 2.311	0.091 2.311	0.126 3.200	0.126 3.200	--	--
1/2 in. 15 mm	0.840 21.336	0.109 2.769	0.109 2.769	0.147 3.734	0.147 3.734	0.188 4.775	0.294 7.468
3/4 in. 20 mm	1.050 26.670	0.113 2.870	0.113 2.870	0.154 3.912	0.154 3.912	0.219 5.563	0.308 7.823
1 in. 25 mm	1.315 33.401	0.133 3.378	0.133 3.378	0.179 4.547	0.179 4.547	0.250 6.350	0.358 9.903
1 1/4 in. 32 mm	1.660 42.164	0.140 3.556	0.140 3.556	0.191 4.851	0.191 4.851	0.250 6.350	0.382 9.703
1 1/2 in. 40 mm	1.900 48.260	0.145 3.683	0.145 3.683	0.200 5.080	0.200 5.080	0.281 7.137	0.400 10.160
2 in. 50 mm	2.375 60.325	0.154 3.912	0.154 3.912	0.218 5.537	0.218 5.537	0.344 8.738	0.436 11.074
2 1/2 in. 65 mm	2.875 73.025	0.203 5.156	0.203 5.156	0.276 7.010	0.276 7.010	0.375 9.525	0.552 14.021
3 in. 80 mm	3.500 88.900	0.216 5.486	0.216 5.486	0.300 7.620	0.300 7.620	0.438 11.125	0.600 15.240
3 1/2 in. 90 mm	4.000 101.600	0.226 5.740	0.226 5.740	0.318 8.077	0.318 8.077	--	--
4 in. 100 mm	4.500 114.300	0.237 6.020	0.237 6.020	0.337 8.560	0.337 8.560	0.531 13.487	0.674 17.120
5 in. 125 mm	5.563 141.300	0.258 6.553	0.258 6.553	0.375 9.525	0.375 9.525	0.625 15.875	0.750 19.050
6 in. 150 mm	6.625 168.275	0.280 7.112	0.280 7.112	0.432 10.973	0.432 10.973	0.719 18.263	0.864 21.946
8 in. 200 mm	8.625 219.075	0.322 8.179	0.322 8.179	0.500 12.700	0.500 12.700	0.906 23.012	0.875 22.225
10 in. 250 mm	10.750 273.050	0.365 9.271	0.365 9.271	0.500 12.700	0.594 15.088	1.125 28.575	1.000 25.400
12 in. 300 mm	12.750 323.850	0.375 9.525	0.406 10.312	0.500 12.700	0.688 17.475	1.312 33.325	1.000 25.400
14 in. 350 mm	14.000 355.600	0.375 9.525	0.438 11.125	0.500 12.700	0.750 19.050	1.406 35.712	--
16 in. 400 mm	16.000 406.400	0.375 9.525	0.500 12.700	0.500 12.700	0.844 21.438	1.594 40.488	--
18 in. 450 mm	18.000 457.200	0.375 9.525	0.562 14.275	0.500 12.700	0.938 23.825	1.781 45.231	--
20 in. 500 mm	20.000 508.000	0.375 9.525	0.594 15.088	0.500 12.700	1.031 26.187	1.969 50.013	--
22 in. 550 mm	22.000 558.800	0.375 9.525	--	0.500 12.700	1.125 28.575	2.125 53.975	--
24 in. 600 mm	24.000 609.600	0.375 9.525	0.688 17.475	0.500 12.700	1.219 30.963	2.344 59.538	--

These pipe sizes and wall thicknesses are according to ANSI B36.10.

TABLE 9
Examples of Mechanical Joints

<i>Pipe Unions</i>	
Welded and Brazed Types	
<i>Compression Couplings</i>	
Swage Type	
Press Type	
Bite Type	
Flared Type	

TABLE 9 (continued)
Examples of Mechanical Joints

<i>Slip-on Joints</i>	
Grip Type	
Machine Grooved Type	<p style="text-align: center;">Roll Groove</p>
	<p style="text-align: center;">Cut Groove</p>
Slip Type	<p style="text-align: center;">Stop Bolt Setting Bolt</p> <p style="text-align: center;">Packing</p> <p style="text-align: center;">Body</p>

TABLE 10
Application of Mechanical Joints

The following table indicates systems where the various kinds of joints may be accepted. However, in all cases, acceptance of the joint type is to be subject to approval for the intended application, and subject to conditions of the approval and applicable Rules.

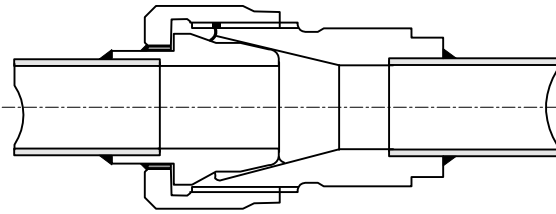
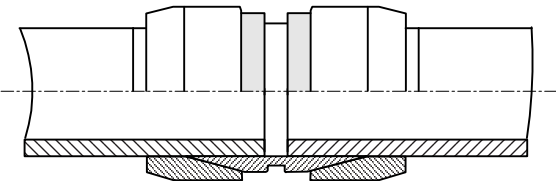
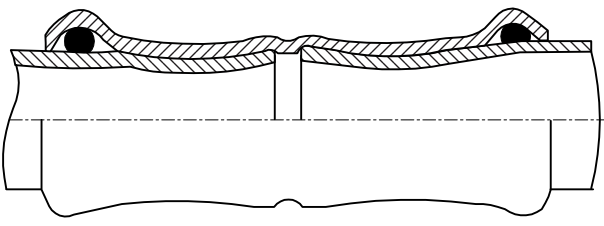
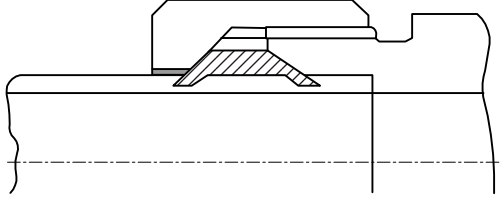
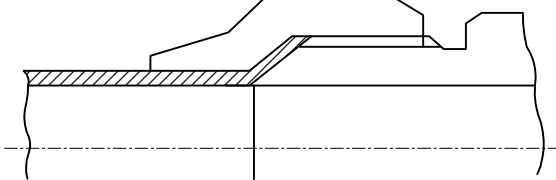
Systems		Kind of Connections		
		Pipe Unions	Compression Couplings ⁽⁶⁾	Slip-on Joints
<i>Flammable Fluids (Flash Point ≤ 60°)</i>				
1	Cargo oil lines ⁽⁴⁾	Y	Y	Y ⁽¹¹⁾
2	Crude oil washing lines ⁽⁴⁾	Y	Y	Y
3	Vent lines ⁽³⁾	Y	Y	Y ⁽¹³⁾
<i>Inert gas</i>				
4	Water seal effluent lines	Y	Y	Y ⁽¹⁶⁾
5	Scrubber effluent lines	Y	Y	Y
6	Main lines ^(2, 4)	Y	Y	Y
7	Distributions lines ⁽⁴⁾	Y	Y	Y
<i>Flammable Fluids (Flash Point > 60°)</i>				
8	Cargo oil lines ⁽⁴⁾	Y	Y	Y ⁽¹¹⁾
9	Fuel oil lines ^(3, 2)	Y	Y	Y
10	Lubricating oil lines ^(2, 3)	Y	Y	Y
11	Hydraulic oil ^(2, 3)	Y	Y	Y ⁽¹²⁾
12	Thermal oil ^(2, 3)	Y	Y	Y
<i>Sea Water</i>				
13	Bilge lines ⁽¹⁾	Y	Y	Y ⁽⁸⁾
14	Water filled fire extinguishing systems (e.g., sprinkler systems) ⁽³⁾	Y	Y	Y ⁽⁷⁾
15	Non water filled fire extinguishing systems (e.g., foam, drencher systems) ⁽³⁾	Y	Y	Y ⁽⁷⁾
16	Fire main (not permanently filled) ⁽³⁾	Y	Y	Y ⁽⁷⁾
17	Ballast system ⁽¹⁾	Y	Y	Y ^(9, 10)
18	Cooling water system ⁽¹⁾	Y	Y	Y
19	Tank cleaning services	Y	Y	Y
20	Non-essential systems	Y	Y	Y
<i>Fresh Water</i>				
21	Cooling water system ⁽¹⁾	Y	Y	Y ⁽⁸⁾
22	Condensate return ⁽¹⁾	Y	Y	Y ⁽⁸⁾
23	Non-essential system	Y	Y	Y
<i>Sanitary/Drains/Scuppers</i>				
24	Deck drains (internal) ⁽⁶⁾	Y	Y	Y ⁽⁴⁾
25	Sanitary drains	Y	Y	Y
26	Scuppers and discharge (overboard)	Y	Y	N ⁽¹⁴⁾
<i>Sounding/Vent</i>				
27	Water tanks/Dry spaces	Y	Y	Y
28	Oil tanks (f.p. > 60°C) ^(2, 3)	Y	Y	Y
<i>Miscellaneous</i>				
29	Starting/Control air ⁽¹⁾	Y	Y	N
30	Service air (non-essential)	Y	Y	Y
31	Brine	Y	Y	Y
32	CO ₂ system ⁽¹⁾	Y	Y	N
33	Steam	Y	Y	Y ^(5, 15)

TABLE 10 (continued)
Application of Mechanical Joints

Abbreviations

Y – Application is allowed

N – Application is not allowed

Footnotes – Fire Resistance Capability:

If mechanical joints include any components which readily deteriorate in case of fire, they are to be of an approved fire resistant type under consideration of the following footnotes:

- 1 Inside machinery spaces of category A – only approved fire resistant types.
- 2 Not inside machinery spaces of category A or accommodation spaces. May be accepted in other machinery spaces provided the joints are located in easily visible and accessible positions.
- 3 Approved fire resistant types except in cases where such mechanical joints are installed on exposed open decks, as defined in SOLAS II-2/Reg. 9.2.3.3.2.2(10) and not used for fuel oil lines.
- 4 In pump rooms and open decks – only approved fire resistant types.

Footnotes – General:

- 5 Slip type slip-on joints as shown in 4-6-2/Table 9, may be used for pipes on deck with a design pressure of 10 bar or less.
- 6 Only above bulkhead deck of passenger ships and freeboard deck of cargo ships.
- 7 In accessible locations at all times under normal condition.
- 8 In accessible locations in machinery spaces, container holds carrying non-dangerous goods, shaft tunnels, pipe tunnels, etc.
- 9 In accessible locations in machinery spaces, shaft tunnels, pipe tunnels, etc. In pipelines located within other ballast tanks. For tankers, in clean or dirty ballast lines provided lines terminate in cargo pump room [see 5C-1-7/5.3.2(a) of the Rules for prohibitions].
- 10 Inside pump room – only with approved fire resistant types.
- 11 Within cargo tanks.
- 12 Not permitted in steering gear hydraulic systems, otherwise Class III systems only.
- 13 On vent risers on decks only.
- 14 Accessible location inboard of required shell valve(s) may be permitted. Slip-on joints are not permitted where there are no shell valve(s), for example, when outboard end >450 mm below freeboard deck or outboard end < 600 mm above summer waterline. For such instances, the overboard piping is required to be of substantial thickness per definition in 4-6-2/9.13.3.
- 15 Permitted in Class III piping in machinery spaces of Category A, other machinery spaces, accommodation spaces and open deck.
- 16 On the open deck only.

TABLE 11
Application of Mechanical Joints Depending Upon the Class of Piping

<i>Types of Joints</i>	<i>Classes of Piping Systems</i>		
	<i>Class I</i>	<i>Class II</i>	<i>Class III</i>
<i>Pipe Unions</i>			
Welded and brazed type	Y (OD ≤ 60.3 mm)	Y (OD ≤ 60.3 mm)	Y
<i>Compression Couplings</i>			
Swage type	Y	Y	Y
Bite type	Y (OD ≤ 60.3 mm)	Y (OD ≤ 60.3 mm)	Y
Flared type	Y (OD ≤ 60.3 mm)	Y (OD ≤ 60.3 mm)	Y
Press type	N	N	Y
<i>Slip-on joints</i>			
Machine grooved type	Y	Y	Y
Grip type	N	Y	Y
Slip type	N	Y	Y

Abbreviations:

Y – Application is allowed

N – Application is not allowed

TABLE 12
Testing Requirements for Mechanical Joints

<i>Tests</i>		<i>Types of Mechanical Joints</i>			<i>Notes and References</i>
		<i>Compression Couplings and Pipe Unions</i>	<i>Slip-on Joints</i>		
			<i>Grip Type & Machine Grooved Type</i>	<i>Slip Type</i>	
1	Tightness test	Y	Y	Y	4-6-2/5.9.2(e)v1
2	Vibration (fatigue) test	Y	Y	N	4-6-2/5.9.2(e)v2
3	Pressure pulsation test ⁽¹⁾	Y	Y	N	4-6-2/5.9.2(e)v3
4	Burst pressure test	Y	Y	Y	4-6-2/5.9.2(e)v4
5	Pull-out test	Y	Y	N	4-6-2/5.9.2(e)v5
6	Fire endurance test	Y	Y	Y	4-6-2/5.9.2(e)v6 If required by 4-6-2/5.9.1(e)
7	Vacuum test	Y ⁽²⁾	Y	Y	4-6-2/5.9.2(e)v7 for suction lines only
8	Repeated assembly test	Y ⁽³⁾	Y	N	4-6-2/5.9.2(e)v8

Abbreviations:

Y - Test is required

N - Test is not required

Notes:

- 1 For use in those systems where pressure pulsation other than water hammer is expected (e.g., systems using positive displacement pumps).
- 2 Except joints with metal-to-metal tightening surfaces.
- 3 Except press type.

PART

4

CHAPTER 6 Piping Systems

SECTION 3 Plastic Piping

1 General

Pipes and piping components made of thermoplastic or thermosetting plastic materials, with or without reinforcement, may be used in piping systems referred to in 4-6-3/Table 1 subject to compliance with the following requirements. For the purpose of these Rules “plastic” means both thermoplastic and thermosetting plastic materials, with or without reinforcement, such as polyvinyl chloride (PVC) and fiber reinforced plastics (FRP). Plastic includes synthetic rubber and materials of similar thermo/mechanical properties.

3 Plans and Data to be Submitted

Rigid plastic piping is to be in accordance with a recognized national or international standard acceptable to ABS. Specifications for the plastic piping, including thermal and mechanical properties and chemical resistance, are to be submitted for review together with the spacing of the pipe supports.

The following information for the plastic pipes, fittings and joints is to be also submitted for approval.

3.1 General Information

- i)* Pipe and fitting dimensions
- ii)* Maximum internal and external working pressure
- iii)* Working temperature range
- iv)* Intended services and installation locations
- v)* Level of fire endurance
- vi)* Electrical conductivity
- vii)* Intended fluids
- viii)* Limits on flow rates
- ix)* Serviceable life
- x)* Installation instructions
- xi)* Details of marking

3.3 Drawings and Supporting Documentation

- i)* Certificates and reports for relevant tests previously carried out. See 4-6-3/9
- ii)* Details of relevant standards. See 4-6-3/Table 2 and 4-6-3/Table 3
- iii)* All relevant design drawings, catalogues, data sheets, calculations and functional descriptions
- iv)* Fully detailed sectional assembly drawings showing pipe, fittings and pipe connections
- v)* Documentation verifying the certification of the manufacturer’s quality system and that the system addresses the testing requirements in 4-6-3/5.1 through 4-6-3/5.15. See 4-6-3/9.

3.5 Materials

- i) Resin type
- ii) Catalyst and accelerator types and concentration employed in the case of reinforced polyester resin pipes or hardeners where epoxide resins are employed
- iii) A statement detailing all reinforcements employed where the reference number does not identify the mass per unit area or the strand count (Tex System or Yardage System) of a roving used in a filament winding process
- iv) Full information regarding the type of gel-coat or thermoplastic liner employed during construction, as appropriate
- v) Cure/post-cure conditions. The cure and post-cure temperatures and times employed for given resin/reinforcement ratio
- vi) Winding angle and orientation
- vii) Joint bonding procedures and qualification tests results. See 4-6-3/11

5 Design

5.1 Internal Pressure

A pipe is to be designed for an internal pressure not less than the design pressure of the system in which it will be used. The maximum internal pressure, P_{int} , for a pipe is to be the lesser of the following:

$$P_{int} = \frac{P_{sth}}{4} \quad \text{or} \quad P_{int} = \frac{P_{lth}}{2.5}$$

where

P_{sth} = short-term hydrostatic test failure pressure

P_{lth} = long-term hydrostatic test failure pressure (> 100,000 hours)

The hydrostatic tests are to be carried out under the following standard conditions:

Atmospheric pressure = 1 bar (1 kgf/cm², 14.5 psi)

Relative humidity = 30%

Fluid temperature = 25°C (77°F)

The hydrostatic test failure pressure may be verified experimentally or determined by a combination of testing and calculation methods which are to be submitted to ABS for approval.

5.3 External Pressure

External pressure is to be considered for any installation which may be subject to vacuum conditions inside the pipe or a head of liquid on the outside of the pipe. A pipe is to be designed for an external pressure not less than the sum of the pressure imposed by the maximum potential head of liquid outside the pipe plus full vacuum, 1 bar (1 kgf/cm², 14.5 psi), inside the pipe. The maximum external pressure for a pipe is to be determined by dividing the collapse test pressure by a safety factor of 3.

The collapse test pressure may be verified experimentally or determined by a combination of testing and calculation methods which are to be submitted to ABS for approval.

5.5 Axial Strength

The sum of the longitudinal stresses due to pressure, weight and other dynamic and sustained loads is not to exceed the allowable stress in the longitudinal direction. Forces due to thermal expansion, contraction and external loads, where applicable, are to be considered when determining longitudinal stresses in the system.

In the case of fiber reinforced plastic pipes, the sum of the longitudinal stresses is not to exceed one-half of the nominal circumferential stress derived from the maximum internal pressure determined according to 4-6-3/5.1. The allowable longitudinal stress may alternatively be verified experimentally or by a combination of testing and calculation methods.

5.7 Temperature

The maximum allowable working temperature of a pipe is to be in accordance with the manufacturer's recommendations. In each case, it is to be at least 20°C (36°F) lower than the minimum heat distortion temperature of the pipe material determined according to ISO 75 method A or equivalent. The minimum heat distortion temperature is not to be less than 80°C (176°F). This minimum heat distortion temperature requirement is not applicable to pipes and pipe components made of thermoplastic materials, such as polyethylene (PE), polypropylene (PP), polybutylene (PB) and intended for non-essential services.

Where low temperature services are considered, special attention is to be given with respect to material properties.

5.9 Impact Resistance

Plastic pipes and joints are to have a minimum resistance to impact in accordance with a recognized national or international standard such as ASTM D2444 or equivalent. After the impact resistance is tested, the specimen is to be subjected to hydrostatic pressure equal to 2.5 times the design pressure for at least one hour.

5.11 Fire Endurance

4-6-3/Table 1 specifies fire endurance requirements for pipes based upon system and location. Pipes and their associated fittings whose functions or integrity are essential to the safety of the vessel are to meet the indicated fire endurance requirements which are described below.

5.11.1 Level 1

Level 1 will ensure the integrity of a system during a full-scale hydrocarbon fire and is particularly applicable to systems where the loss of integrity may result in outflow of flammable liquids and worsen the fire situation. Piping having passed the fire endurance test specified in 4-6-3/13 hereunder for a duration of a minimum of one hour without loss of integrity in the dry condition is considered to meet the Level 1 fire endurance standard (L1).

Level 1W – Piping systems similar to Level 1 systems except these systems do not carry flammable fluid or any gas and a maximum 5% flow loss in the system after exposure is acceptable. The flow loss must be taken into account when dimensioning the system.

5.11.2 Level 2

Level 2 intends to ensure the availability of systems essential to the safe operation of the vessel after a fire of short duration, allowing the system to be restored after the fire has been extinguished. Piping having passed the fire endurance test specified in 4-6-3/13 hereunder for a duration of a minimum of 30 minutes without loss of integrity in the dry condition is considered to meet the Level 2 fire endurance standard (L2).

Level 2W – Piping systems similar to Level 2 systems except a maximum 5% flow loss in the system after exposure is acceptable. The flow loss must be taken into account when dimensioning the system.

5.11.3 Level 3

Level 3 is considered to provide the fire endurance necessary for a water-filled piping system to survive a local fire of short duration. The system's functions are capable of being restored after the fire has been extinguished. Piping having passed the fire endurance test specified in 4-6-3/15 hereunder for a duration of a minimum of 30 minutes without loss of integrity in the wet condition is considered to meet the Level 3 fire endurance standard (L3).

5.11.4 Fire Endurance Coating

Where a fire protective coating of pipes and fittings is necessary to achieve the fire endurance standard required, the following requirements apply:

- i) Pipes are generally to be delivered from the manufacturer with the protective coating applied, with on-site application limited to that necessary for installation purposes (i.e., joints). See 4-6-3/7.13 regarding the application of the fire protection coating on joints.
- ii) The fire protection properties of the coating are not to be diminished when exposed to salt water, oil or bilge slops. It is to be demonstrated that the coating is resistant to products likely to come in contact with the piping.
- iii) In considering fire protection coatings, such characteristics as thermal expansion, resistance against vibrations and elasticity are to be taken into account.
- iv) The fire protection coatings are to have sufficient resistance to impact to retain their integrity.
- v) Random samples of pipe are to be tested to determine the adhesion qualities of the coating to the pipe.

5.13 Flame Spread

5.13.1 Plastic Pipes

All pipes, except those fitted on open decks and within tanks, cofferdams, void spaces, pipe tunnels and ducts are to have low flame spread characteristics. The test procedures in IMO Resolution A.653(16) *Recommendation on Improved Fire Test Procedures for Surface Flammability of Bulkhead, Ceiling, and Deck Finish Materials*, modified for pipes as indicated in 4-6-3/17 hereunder, are to be used for determining the flame spread characteristics. Piping materials giving average values for all of the surface flammability criteria not exceeding the values listed in Resolution A.653(16) are considered to meet the requirements for low flame spread.

Alternatively, flame spread testing in accordance with ASTM D635 may be used in lieu of the IMO flame spread test provided such testing is acceptable to the appropriate administration of the vessel's registry.

5.13.2 Multi-core Metallic Tubes Sheathed by Plastic Materials

The multi-core tubes in "bundles" made of stainless steel or copper tubes covered by an outer sheath of plastic material are to comply with the flammability test criteria of IEC 60332-3-22 or 60332-3-21, for Category A or A F/R, respectively. Alternatively, the tube bundles complying with at least the flammability test criteria of IEC 60332-1-2 or a test procedure equivalent thereto are acceptable, provided they are installed in compliance with approved fire stop arrangements.

5.15 Electrical Conductivity

5.15.1 Pipe Conductivity

Piping conveying fluids with a conductivity of less than 1000 pico-siemens per meter is to be electrically conductive.

5.15.2 Hazardous Areas

Regardless of the fluid being conveyed, plastic piping is to be electrically conductive if the piping passes through a hazardous area.

5.15.3 Electrical Resistance

Where electrically conductive piping is required, the resistance per unit length of the pipes and fittings is not to exceed $1 \times 10^5 \Omega/\text{m}$ ($3 \times 10^4 \Omega/\text{ft}$). See also 4-6-3/7.7.

5.15.4 Non-homogeneous Conductivity

Pipes and fittings with layers having different conductivity are to be protected against the possibility of spark damage to the pipe wall.

5.17 Marking

Plastic pipes and other components are to be permanently marked with identification in accordance with a recognized standard. Identification is to include pressure ratings, the design standard that the pipe or fitting is manufactured in accordance with, the material with which the pipe or fitting is made, and the date of fabrication.

7 Installation of Plastic Pipes

7.1 Supports

7.1.1 Spacing

Selection and spacing of pipe supports in shipboard systems are to be determined as a function of allowable stresses and maximum deflection criteria. Support spacing is not to be greater than the pipe manufacturer's recommended spacing. The selection and spacing of pipe supports are to take into account pipe dimensions, length of the piping, mechanical and physical properties of the pipe material, mass of pipe and contained fluid, external pressure, operating temperature, thermal expansion effects, loads due to external forces, thrust forces, water hammer and vibrations to which the system may be subjected. Combinations of these loads are to be checked.

7.1.2 Bearing

Each support is to evenly distribute the load of the pipe and its contents over the full width of the support. Measures are to be taken to minimize wear of the pipes where they contact the supports.

7.1.3 Heavy Components

Heavy components in the piping system such as valves and expansion joints are to be independently supported.

7.1.4 Working of the Hull

The supports are to allow for relative movement between the pipes and the vessel's structure, having due regard to the difference in the coefficients of thermal expansion and deformations of the vessel's hull and its structure.

7.1.5 Thermal Expansion

When calculating the thermal expansion, the system working temperature and the temperature at which assembling is performed are to be taken into account.

7.3 External Loads

When installing the piping, allowance is to be made for temporary point loads, where applicable. Such allowances are to include at least the force exerted by a load (person) of 980 N (100 kgf, 220 lbf) at mid-span on any pipe more than 100 mm (4 in.) nominal diameter.

Pipes are to be protected from mechanical damage, where necessary.

7.5 Plastic Pipe Connections

7.5.1 General Requirements

The following general principles are applicable to all pipe connections:

- i)* The strength of fittings and joints is not to be less than that of the piping they connect.
- ii)* Pipes may be joined using adhesive-bonded, welded, flanged or other joints.
- iii)* Tightening of flanged or mechanically coupled joints is to be performed in accordance with manufacturer's instructions.
- iv)* Adhesives, when used for joint assembly, are to be suitable for providing a permanent seal between the pipes and fittings throughout the temperature and pressure range of the intended application.

7.5.2 Procedure and Personal Qualifications

Joining techniques are to be in accordance with manufacturer's installation guidelines. Personnel performing these tasks are to be qualified to the satisfaction of ABS, and each bonding procedure is to be qualified before shipboard piping installation commences. Requirements for joint bonding procedures are in 4-6-3/11.

7.7 Electrical Conductivity

Where electrically conductive pipe is required by 4-6-3/5.15, installation of the pipe is to be in accordance with the following provisions.

7.7.1 Resistance Measurement

The resistance to earth (ground) from any point in the system is not to exceed 1 MΩ. The resistance is to be checked in the presence of the Surveyor.

7.7.2 Earthing Wire

Where used, earthing wires or bonding straps are to be accessible for inspection. The Surveyor is to verify that they are in visible locations.

7.9 Shell Connections

Where plastic pipes are permitted in systems connected to the shell of the vessel, the valves installed on the shell and the pipe connection to the shell are to be metallic. The side shell valves are to be arranged for remote control from outside the space in which the valves are located. For further details of the shell valve installation, their connections and material, refer to 4-6-2/9.13.

7.11 Bulkhead and Deck Penetrations

Where it is intended to pass plastic pipes through bulkheads or decks, the following general principles are to be complied with:

- i) The integrity of watertight bulkheads and decks is to be maintained where plastic pipes pass through them.
- ii) Where plastic pipes pass through "A" or "B" class divisions, arrangements are to be made to ensure that the fire endurance is not impaired. These arrangements are to be tested in accordance with IMO Resolution. A.754(18), *Recommendation on Fire Resistance Tests for "A", "B" and "F" Class Divisions*, as amended.
- iii) If the bulkhead or deck is also a fire division and destruction by fire of plastic pipes may cause inflow of liquid from a tank, then a metallic shutoff valve operable from above the bulkhead deck is to be fitted at the bulkhead or deck.

7.13 Application of Fire Protection Coatings

Fire protection coatings are to be applied on the joints, where necessary for meeting the required fire endurance criteria in 4-6-3/5.11, after performing hydrostatic pressure tests of the piping system (see 4-6-3/19). The fire protection coatings are to be applied in accordance with the manufacturer's recommendations, using a procedure approved in each particular case.

9 Manufacturing of Plastic Pipes

The manufacturer is to have a quality system and be certified in accordance with 1-1-A3/5.3, 1-1-A3/5.5 or ISO 9001 (or equivalent). The quality system is to consist of elements necessary to ensure that pipes and components are produced with consistent and uniform mechanical and physical properties in accordance with recognized standards, including testing to demonstrate the compliance of plastic pipes, fittings and joints with 4-6-3/5.1 through 4-6-3/5.15 and 4-6-3/19, as applicable.

Where the manufacturer does not have a certified quality system in accordance with 1-1-A3/5.3, 1-1-A3/5.5 or ISO 9001 (or equivalent), the tests in 4-6-3/5.1 through 4-6-3/5.15 and 4-6-3/19, as applicable, will be required using samples from each batch of pipes being supplied for use aboard the vessel and are to be carried out in the presence of the Surveyor.

Each length of pipe and each fitting is to be tested at the manufacturer's production facility to a hydrostatic pressure not less than 1.5 times the maximum allowable internal pressure of the pipe in 4-6-3/5.1. Alternatively, for pipes and fittings not employing hand lay up techniques, the hydrostatic pressure test may be carried out in accordance with the hydrostatic testing requirements stipulated in the recognized national or international standard to which the pipe or fittings are manufactured, provided that there is an effective quality system in place.

Depending upon the intended application, ABS reserves the right to require the hydrostatic pressure testing of each pipe and/or fitting.

If the facility does not have a certified quality system in accordance with 1-1-A3/5.3, 1-1-A3/5.5 or ISO 9001 (or equivalent), then the production testing is to be witnessed by the Surveyor.

The manufacturer is to provide documentation certifying that all piping and piping components supplied are in compliance with the requirements of Section 4-6-3.

11 Plastic Pipe Bonding Procedure Qualification

11.1 Procedure Qualification Requirements

11.1.1 Joint Bonding Parameters

To qualify joint bonding procedures, the tests and examinations specified herein are to be successfully completed. The procedure for making bonds is to include the following:

- Materials used
- Tools and fixtures
- Environmental requirements
- Joint preparation requirements
- Cure temperature
- Dimensional requirements and tolerances
- Test acceptance criteria for the completed assembly

11.1.2 Requalification

Any change in the bonding procedure which will affect the physical and mechanical properties of the joint will require the procedure to be requalified.

11.3 Procedure Qualification Testing

11.3.1 Test Assembly

A test assembly is to be fabricated in accordance with the procedure to be qualified, and it is to consist of at least one pipe-to-pipe joint and one pipe-to-fitting joint. When the test assembly has been cured, it is to be subjected to a hydrostatic test pressure at a safety factor of 2.5 times the design pressure of the test assembly for not less than one hour. No leakage or separation of joints is to be allowed. The test is to be conducted so that the joint is loaded in both longitudinal and circumferential direction.

11.3.2 Pipe Size

Selection of the pipes used for test assembly is to be in accordance with the following:

- i) When the largest size to be joined is 200 mm (8 in.) nominal outside diameter or smaller, the test assembly is to be the largest pipe size to be joined.
- ii) When the largest size to be joined is greater than 200 mm (8 in.) nominal outside diameter, the size of the test assembly is to be either 200 mm (8 in.) or 25% of the largest piping size to be joined, whichever is greater.

11.3.3 Bonding Operator Qualification

When conducting performance qualifications, each bonder and each bonding operator are to make up test assemblies, the size and number of which are to be as required above.

13 Tests by the Manufacturer – Fire Endurance Testing of Plastic Piping in the Dry Condition (for Level 1 and Level 2)

13.1 Test Method

13.1.1 Furnace Test Temperature

The specimen is to be subjected to a furnace test with fast temperature increase similar to that likely to occur in a fully developed liquid hydrocarbon fire. The time/temperature is to be as follows:

At the end of 5 minutes	945°C	(1733°F)
At the end of 10 minutes	1033°C	(1891°F)
At the end of 15 minutes	1071°C	(1960°F)
At the end of 30 minutes	1098°C	(2008°F)
At the end of 60 minutes	1100°C	(2012°F)

13.1.2 Furnace Temperature Control

The accuracy of the furnace control is to be as follows:

- i) During the first 10 minutes of the test, variation in the area under the curve of mean furnace temperature is to be within $\pm 15\%$ of the area under the standard curve.
- ii) During the first 30 minutes of the test, variation in the area under the curve of mean furnace temperature is to be within $\pm 10\%$ of the area under the standard curve.
- iii) For any period after the first 30 minutes of the test, variation in the area under the curve of mean furnace temperature is to be within $\pm 5\%$ of the area under the standard curve.
- iv) At any time after the first 10 minutes of the test, the difference in the mean furnace temperature from the standard curve is to be within $\pm 100^\circ\text{C}$ ($\pm 180^\circ\text{F}$).

13.1.3 Furnace Temperature Measurement

The locations where the temperatures are measured, the number of temperature measurements and the measurement techniques are to be approved by ABS.

13.3 Test Specimen

13.3.1 Pipe Joints and Fittings

The test specimen is to be prepared with the joints and fittings intended for use in the proposed application.

13.3.2 Number of Specimens

The number of specimens is to be sufficient to test typical joints and fittings including joints between non-metal and metal pipes and metal fittings to be used.

13.3.3 End Closure

The ends of the specimen are to be closed. One of the ends is to allow pressurized nitrogen to be connected. The pipe ends and closures may be outside the furnace.

13.3.4 Orientation

The general orientation of the specimen is to be horizontal and it is to be supported by one fixed support with the remaining supports allowing free movement. The free length between supports is not to be less than 8 times the pipe diameter.

13.3.5 Insulation

Most materials will require a thermal insulation to pass this test. The test procedure is to include the insulation and its covering.

13.3.6 Moisture Condition of Insulation

If the insulation contains or is liable to absorb moisture, the specimen is not to be tested until the insulation has reached an air dry-condition, defined as equilibrium with an ambient atmosphere of 50% relative humidity at $20 \pm 5^\circ\text{C}$ ($68 \pm 9^\circ\text{F}$). Accelerated conditioning is permissible provided the method does not alter the properties of the component material. Special samples are to be used for moisture content determination and conditioned with the test specimen. These samples are to be so constructed as to represent the loss of water vapor from the specimen having similar thickness and exposed faces.

13.5 Test Condition

A nitrogen pressure inside the test specimen is to be automatically maintained at 0.7 ± 0.1 bar (0.7 ± 0.1 kgf/cm², 10 ± 1.5 psi) during the test. Means are to be provided to record the pressure inside the pipe and the nitrogen flow into and out of the specimen in order to indicate leakage.

13.7 Acceptance Criteria

13.7.1 During the Test

During the test, no nitrogen leakage from the sample is to occur.

13.7.2 After the Test

After termination of the furnace test, the test specimen together with fire protective coating, if any, is to be allowed to cool in still air to ambient temperature and then tested to the maximum allowable pressure of the pipes, as defined in 4-6-3/5.1 and 4-6-3/5.3. The pressure is to be held for a minimum of 15 minutes. Pipes without leakage qualify as Level 1 or 2 depending on the test duration. Pipes with negligible leakage (i.e., not exceeding 5% flow loss) qualify as Level 1W or Level 2W depending on the test duration. Where practicable, the hydrostatic test is to be conducted on bare pipe (i.e., coverings and insulation removed) so that any leakage will be visible.

13.7.3 Alternative Tests

Alternative test methods and/or test procedures considered to be at least equivalent, including open pit testing method, may be accepted in cases where the pipes are too large for the test furnace.

15 Test by Manufacturer – Fire Endurance Testing of Water-filled Plastic Piping (for Level 3)

15.1 Test Method

15.1.1 Burner

A propane multiple burner test with a fast temperature increase is to be used.

15.1.2 Pipes up to 152 mm (6 in.) OD

For piping up to and including 152 mm (6 in.) OD, the fire source is to consist of two rows of five burners, as shown in 4-6-3/Figure 1. A constant heat flux averaging 113.6 kW/m^2 ($36,000 \text{ BTU/h-ft}^2$) $\pm 10\%$ is to be maintained at the $12.5 \pm 1 \text{ cm}$ ($5 \pm 0.4 \text{ in.}$) height above the centerline of the burner array. This flux corresponds to a pre-mix flame of propane with a fuel flow rate of 5 kg/h (11 lb/h) for a total heat release of 65 kW (3700 BTU/min.). The gas consumption is to be measured with an accuracy of at least $\pm 3\%$ in order to maintain a constant heat flux. Propane with a minimum purity of 95% is to be used.

15.1.3 Pipes More than 152 mm (6 in.) OD

For piping greater than 152 mm (6 in.) OD, one additional row of burners is to be included for each 50 mm (2 in.) increase in pipe diameter. A constant heat flux averaging 113.6 kW/m^2 ($36,000 \text{ BTU/h-ft}^2$) $\pm 10\%$ is still to be maintained at the $12.5 \pm 1 \text{ cm}$ ($5 \pm 0.4 \text{ in.}$) height above the centerline of the burner array. The fuel flow is to be increased as required to maintain the designated heat flux.

15.1.4 Burner Type and Arrangement

The burners are to be type “Sievert No. 2942” or equivalent which produces an air mixed flame. The inner diameter of the burner heads is to be 29 mm (1.14 in.). See 4-6-3/Figure 1. The burner heads are to be mounted in the same plane and supplied with gas from a manifold. If necessary, each burner is to be equipped with a valve in order to adjust the flame height.

15.1.5 Burner Position

The height of the burner stand is also to be adjustable. It is to be mounted centrally below the test pipe with the rows of burners parallel to the pipe’s axis. The distance between the burner heads and the pipe is to be maintained at 12.5 ± 1 cm (5 ± 0.4 in.) during the test. The free length of the pipe between its supports is is to be 0.8 ± 0.05 m (31.5 ± 2 in.). See 4-6-3/Figure 2.

FIGURE 1
Fire Endurance Test Burner Assembly

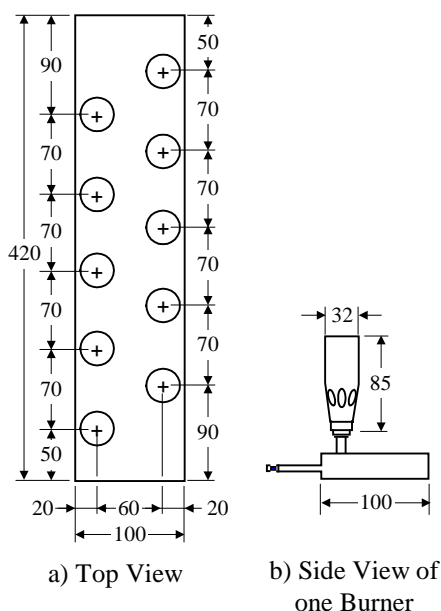
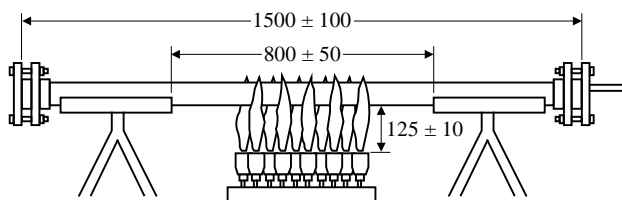

FIGURE 2
Fire Endurance Test Stand with Mounted Sample



15.3 Test Specimen

15.3.1 Pipe Length

Each pipe is to have a length of approximately 1.5 m (5 ft).

15.3.2 Pipe Joints and Fittings

The test pipe is to be prepared with the permanent joints and fittings intended to be used. Only valves and straight joints versus elbows and bends are to be tested as the adhesive in the joint is the primary point of failure.

15.3.3 Number of Specimens

The number of pipe specimens is to be sufficient to test all typical joints and fittings.

15.3.4 End Closure

The ends of each pipe specimen are to be closed, except to allow pressurized water and air vent to be connected.

15.3.5 Moisture of Insulation

If the insulation contains or is liable to absorb moisture, the specimen is not to be tested until the insulation has reached an air dry-condition, defined as equilibrium with an ambient atmosphere of 50% relative humidity at $20 \pm 5^\circ\text{C}$ ($68 \pm 9^\circ\text{F}$). Accelerated conditioning is permissible provided the method does not alter the properties of the component material. Special samples are to be used for moisture content determination and conditioned with the test specimen. These samples are to be so constructed as to represent the loss of water vapor from the specimen having similar thickness and exposed faces.

15.3.6 Orientation

The pipe samples are to rest freely in a horizontal position on two V-shaped supports. The friction between pipe and supports is to be minimized. The supports may consist of two stands, as shown in 4-6-3/Figure 2.

15.3.7 Relief Valve

A relief valve is to be connected to one of the end closures of each specimen

15.5 Test Conditions

15.5.1 Sheltered Test Site

The test is to be carried out in a sheltered test site in order to prevent any draft influencing the test.

15.5.2 Water-filled

Each pipe specimen is to be completely filled with deaerated water to exclude air bubbles.

15.5.3 Water Temperature

The water temperature is not to be less than 15°C (59°F) at the start and is to be measured continuously during the test. The water is to be stagnant and the pressure maintained at 3 ± 0.5 bar (3.1 ± 0.5 kgf/cm², 43.5 ± 7.25 psi) during the test.

15.7 Acceptance Criteria

15.7.1 During the Test

During the test, no leakage from the sample(s) is to occur except that slight weeping through the pipe wall may be accepted.

15.7.2 After the Test

After termination of the burner test, the test specimen together with fire protective coating, if any, is to be allowed to cool to ambient temperature and then tested to the maximum allowable pressure of the pipes, as defined in 4-6-3/5.1 and 4-6-3/5.3. The pressure is to be held for a minimum of 15 minutes without significant leakage [i.e., not exceeding 0.2 l/min. (0.05 gpm)]. Where practicable, the hydrostatic test is to be conducted on bare pipe (i.e., coverings and insulation removed) so that any leakage will be visible.

17 Tests by Manufacturer – Flame Spread

17.1 Test Method

Flame spread of plastic piping is to be determined by IMO Resolution A.653(16) *Recommendation on Improved Fire Test Procedures for Surface Flammability of Bulkhead, Ceiling, and Deck Finish Materials* with the following modifications.

- i) Tests are to be made for each pipe material and size.
- ii) The test sample is to be fabricated by cutting pipes lengthwise into individual sections and then assembling the sections into a test sample as representative as possible of a flat surface. A test sample is to consist of at least two sections. The test sample is to be at least 800 ± 5 mm (31.5 ± 0.2 in.) long. All cuts are to be made normal to the pipe wall.
- iii) The number of sections that must be assembled together to form a test sample is to be that which corresponds to the nearest integral number of sections which makes up a test sample with an equivalent linearized surface width between 155 mm (6 in.) and 180 mm (7 in.). The surface width is defined as the measured sum of the outer circumference of the assembled pipe sections that are exposed to the flux from the radiant panel.
- iv) The assembled test sample is to have no gaps between individual sections.
- v) The assembled test sample is to be constructed in such a way that the edges of two adjacent sections coincide with the centerline of the test holder.
- vi) The individual test sections are to be attached to the backing calcium silicate board using wire (No. 18 recommended) inserted at 50 mm (2 in.) intervals through the board and tightened by twisting at the back.
- vii) The individual pipe sections are to be mounted so that the highest point of the exposed surface is in the same plane as the exposed flat surface of a normal surface.
- viii) The space between the concave unexposed surface of the test sample and the surface of the calcium silicate backing board is to be left void.
- ix) The void space between the top of the exposed test surface and the bottom edge of the sample holder frame is to be filled with a high temperature insulating wool if the width of the pipe segments extend under the side edges of the sample holding frame.

19 Testing by Manufacturer – General

Testing is to demonstrate the compliance with 4-6-3/5.1 through 4-6-3/5.15, as applicable, for plastic pipes, fittings and joints for which approval in accordance with Section 4-6-3 is requested. These tests are to be in compliance with the requirements of relevant standards as per 4-6-3/Table 2 and 4-6-3/Table 3. Other recognized standards may be considered.

21 Testing Onboard After Installation

Piping systems are to be subjected to a hydrostatic test pressure of not less than 1.5 times the design pressure to the satisfaction of the Surveyor.

For piping required to be electrically conductive, earthing is to be checked and random resistance testing is to be conducted to the satisfaction of the Surveyor.

TABLE 1
Fire Endurance Requirement Matrix

PIPING SYSTEMS		LOCATION										
		A	B	C	D	E	F	G	H	I	J	K
CARGO (Flammable cargoes with flash point ≤ 60°C (140°F))												
1	Cargo lines	NA	NA	L1	NA	NA	0	NA	0 ⁽¹⁰⁾	0	NA	L1 ⁽²⁾
2	Crude oil washing lines	NA	NA	L1	NA	NA	0	NA	0 ⁽¹⁰⁾	0	NA	L1 ⁽²⁾
3	Vent lines	NA	NA	NA	NA	NA	0	NA	0 ⁽¹⁰⁾	0	NA	X
INERT GAS												
4	Water seal effluent line	NA	NA	0 ⁽¹⁾	NA	NA	0 ⁽¹⁾	0 ⁽¹⁾	0 ⁽¹⁾	0 ⁽¹⁾	NA	0
5	Scrubber effluent line	0 ⁽¹⁾	0 ⁽¹⁾	NA	NA	NA	NA	NA	0 ⁽¹⁾	0 ⁽¹⁾	NA	0
6	Main line	0	0	L1	NA	NA	NA	NA	NA	0	NA	L1 ⁽⁶⁾
7	Distribution lines	NA	NA	L1	NA	NA	0	NA	NA	0	NA	L1 ⁽²⁾
FLAMMABLE LIQUIDS [flash point > 60°C (140°F)]												
8	Cargo lines	X	X	L1	X	X	NA ⁽³⁾	0	0 ⁽¹⁰⁾	0	NA	L1
9	Fuel oil	X	X	L1	X	X	NA ⁽³⁾	0	0	0	L1	L1
10	Lubricating oil	X	X	L1	X	X	NA	NA	NA	0	L1	L1
11	Hydraulic oil	X	X	L1	X	X	0	0	0	0	L1	L1
SEA WATER (See Note 1)												
12	Bilge main and branches	L1 ⁽⁷⁾	L1 ⁽⁷⁾	L1	X	X	NA	0	0	0	NA	L1
13	Fire main and water spray	L1	L1	L1	X	NA	NA	NA	0	0	X	L1
14	Foam system	L1W	L1W	L1W	NA	NA	NA	NA	NA	0	L1W	L1W
15	Sprinkler system	L1W	L1W	L3	X	NA	NA	NA	0	0	L3	L3
16	Ballast	L3	L3	L3	L3	X	0 ⁽¹⁰⁾	0	0	0	L2W	L2W
17	Cooling water, essential services	L3	L3	NA	NA	NA	NA	NA	0	0	NA	L2W
18	Tank cleaning services, fixed machines	NA	NA	L3	NA	NA	0	NA	0	0	NA	L3 ⁽²⁾
19	Non-essential systems	0	0	0	0	0	NA	0	0	0	0	0
FRESH WATER												
20	Cooling water, essential services	L3	L3	NA	NA	NA	NA	0	0	0	L3	L3
21	Condensate return	L3	L3	L3	0	0	NA	NA	NA	0	0	0
22	Non-essential systems	0	0	0	0	0	NA	0	0	0	0	0
SANITARY/DRAINS/SCUPPERS												
23	Deck drains (internal)	L1W ⁽⁴⁾	L1W ⁽⁴⁾	NA	L1W ⁽⁴⁾	0	NA	0	0	0	0	0
24	Sanitary drains (internal)	0	0	NA	0	0	NA	0	0	0	0	0
25	Scuppers and discharges (overboard)	0 ^(1,8)	0 ^(1,8)	0 ^(1,8)	0 ^(1,8)	0 ^(1,8)	0	0	0	0	0 ^(1,8)	0
VENTS/SOUNDING												
26	Water tanks/dry spaces	0	0	0	0	0	0 ⁽¹⁰⁾	0	0	0	0	0
27	Oil tanks [flashpoint > 60°C (140°F)]	X	X	X	X	X	X ⁽³⁾	0	0 ⁽¹⁰⁾	0	X	X
MISCELLANEOUS												
28	Control air	L1 ⁽⁵⁾	L1 ⁽⁵⁾	L1 ⁽⁵⁾	L1 ⁽⁵⁾	L1 ⁽⁵⁾	NA	0	0	0	L1 ⁽⁵⁾	L1 ⁽⁵⁾
29	Service air (non-essential)	0	0	0	0	0	NA	0	0	0	0	0
30	Brine	0	0	NA	0	0	NA	NA	NA	0	0	0
31	Auxiliary low pressure steam [Pressure ≤ 7 bar (7 kgf/cm ² , 100 psi)]	L2W	L2W	0 ⁽⁹⁾	0 ⁽⁹⁾	0 ⁽⁹⁾	0	0	0	0	0 ⁽⁹⁾	0 ⁽⁹⁾

TABLE 1 (continued)
Fire Endurance Requirement Matrix

<i>Locations</i>	<i>Abbreviations</i>
A Category A machinery spaces	L1 Fire endurance test in dry conditions, 60 minutes, in accordance with 4-6-3/13
B Other machinery spaces	L2 Fire endurance test in dry conditions, 30 minutes, in accordance with 4-6-3/13
C Cargo pump rooms	L3 Fire endurance test in wet conditions, 30 minutes, in accordance with 4-6-3/15
D Ro-ro cargo holds	0 No fire endurance test required
E Other dry cargo holds	NA Not applicable
F Cargo tanks	X Metallic materials having a melting point greater than 925°C (1700°F).
G Fuel oil tanks	
H Ballast water tanks	
I Cofferdams, void spaces, pipe tunnels and ducts	
J Accommodation, service and control spaces	
K Open decks	

Notes:

- 1 Where non-metallic piping is used, remotely controlled valves are to be provided at the vessel's side. These valves are to be controlled from outside the space.
- 2 Remote closing valves are to be provided at the cargo tanks.
- 3 When cargo tanks contain flammable liquids with a flash point greater than 60°C (140°F), "0" may replace "NA" or "X".
- 4 For drains serving only the space concerned, "0" may replace "L1W".
- 5 When controlling functions are not required by statutory requirements, "0" may replace "L1".
- 6 For pipe between machinery space and deck water seal, "0" may replace "L1".
- 7 For passenger vessels, "X" is to replace "L1".
- 8 Scuppers serving open decks in positions 1 and 2, as defined in Regulation 13 of the International Convention on Load Lines, 1966, are to be "X" throughout unless fitted at the upper end with the means of closing capable of being operated from a position above the freeboard deck in order to prevent downflooding.
- 9 For essential services, such as fuel oil tank heating and ship's whistle, "X" is to replace "0".
- 10 For tankers where compliance with Regulation 19.3.6 of Annex I of MARPOL 73/78 is required, "NA" is to replace "0".

TABLE 2
Standards for Plastic Pipes – Typical Requirements for All Systems

	<i>Test</i>	<i>Typical Standard</i>	<i>Notes</i>
1	Internal pressure ⁽¹⁾	4-6-3/5.1 ASTM D 1599, ASTM D 2992 ISO 15493 or equivalent	Top, Middle, Bottom (of each pressure range) Tests are to be carried out on pipe spools made of different pipe sizes, fittings and pipe connections.
2	External pressure ⁽¹⁾	4-6-3/5.3 ISO 15493 or equivalent	As above, for straight pipes only.
3	Axial strength ⁽¹⁾	4-6-3/5.5	As above.
4	Load deformation	ASTM D 2412 or equivalent	Top, Middle, Bottom (of each pressure range)
5	Temperature limitations ⁽¹⁾	4-6-3/5.7 ISO 75 Method A GRP piping system: HDT test on each type of resin acc. to ISO 75 method A. Thermoplastic piping systems: ISO 75 Method A ISO 306 Plastics - Thermoplastic materials - Determination of Vicat softening temperature (VST) VICAT test according to ISO 2507 Polyesters with an HDT below 80°C should not be used.	Each type of resin
6	Impact resistance ⁽¹⁾	4-6-3/5.9 ISO 9854: 1994, ISO 9653: 1991 ISO 15493 ASTM D 2444, or equivalent	Representative sample of each type of construction
7	Ageing	Manufacturer's standard ISO 9142:1990	Each type of construction
8	Fatigue	Manufacturer's standard or service experience.	Each type of construction
9	Fluid absorption	ISO 8361:1991	
10	Material compatibility ⁽²⁾	ASTM C581 Manufacturer's standard	

Notes:

- 1 Where the manufacturer does not have a certified quality system, test to be witnessed by the Surveyor. See 4-6-3/9.
- 2 If applicable.

TABLE 3
Standards for Plastic Pipes – Additional Requirements Depending on Service and/or Location of Piping

	<i>Test</i>	<i>Typical Standard</i>	<i>Notes</i>
1	Fire endurance ^(1,2)	4-6-3/5.11	Representative samples of each type of construction and type of pipe connection.
2	Flame spread ^(1,2)	(4-6-3/5.13)	Representative samples of each type of construction.
3	Smoke generation ⁽²⁾	IMO Fire Test Procedures Code	Representative samples of each type of construction.
4	Toxicity ⁽²⁾	IMO Fire Test Procedures Code	Representative samples of each type of construction.
5	Electrical conductivity ^(1,2)	4-6-3/5.15 ASTM F1173-95 or ASTM D 257, NS 6126/ 11.2 or equivalent	Representative samples of each type of construction

Notes:

- 1 Where the manufacturer does not have a certified quality system, test to be witnessed by the Surveyor. See 4-6-3/9.
- 2 If applicable.

Note: Test items 1, 2 and 5 in 4-6-3/Table 3 are optional. However, if not carried out, the range of approved applications for the pipes will be limited accordingly (see 4-6-3/Table 1).

PART

4

CHAPTER 6 Piping Systems

SECTION 4 Ship Piping Systems and Tanks

1 General

1.1 Scope

The provisions of Part 4, Chapter 6, Section 4 (referred to as 4-6-4) apply to piping systems – other than liquid cargo systems – serving tanks and normally dry spaces. Piping systems for normally dry spaces include gravity drain and bilge systems. Systems for tanks include ballast systems, fuel oil and lubricating oil storage and transfer systems, and vent, overflow and sounding systems. Additional requirements for fuel oil and lubricating oil systems relating to operation of internal combustion engines, steam turbines and boilers are provided in Section 4-6-5 and Section 4-6-6.

Additional requirements for liquid cargo piping, vent and overflow, sounding, bilge and ballast systems for specialized vessels, including passenger vessels, are provided in Part 5C and Part 5D.

1.3 Effective Drainage

All vessels are to be provided with effective means of pumping out or draining tanks. They are also to have means of draining or pumping bilge water from normally dry compartments and void tanks.

1.5 Damage Stability Consideration

Piping serving tanks and dry spaces, where installed within zones of assumed damage under damage stability conditions, is also to be considered damaged. Damage to such piping is not to lead to progressive flooding of spaces not assumed damaged. If it is not practicable to route piping outside the zone of assumed damage, then means are to be provided to prevent progressive flooding. Such means, for example, may be the provision of a remotely operated valve in the affected piping. Alternatively, intact spaces that can be so flooded are to be assumed flooded in the damage stability conditions.

In addition, where open ended piping systems are located below the bulkhead deck and penetrate watertight subdivision bulkheads, means operable from above the bulkhead deck are to be provided to prevent progressive flooding through those piping systems which remain intact following damage to the vessel.

3 Gravity Drain Systems

3.1 General

3.1.1 Application

These requirements apply to gravity drain systems from watertight and non-watertight spaces located either above or below the freeboard deck.

3.1.2 Definitions

3.1.2(a) Gravity drain system. A gravity drain system is a piping system in which flow is accomplished solely by the difference between the height of the inlet end and the outlet end. For the purposes of the Rules, gravity drain systems include those which discharge both inside and outside the vessel.

3.1.2(b) Gravity discharge. A gravity discharge is an overboard drain from a watertight space such as spaces below freeboard deck or within enclosed superstructures or deckhouses. Back-flooding through a gravity discharge would affect the reserve buoyancy of the vessel.

3.1.2(c) *Inboard end*. The inboard end of an overboard gravity discharge pipe is that part of the pipe at which the discharge originates. The inboard end to be considered for these requirements is the lowest inboard end where water would enter the vessel if back-flooding would occur. See also 4-6-4/9.5.3 for exception to this definition.

3.1.2(d) *Scupper*. A scupper is an overboard drain from a non-watertight space or deck area. Back-flooding through a scupper would not affect the reserve buoyancy of the vessel.

3.1.3 Basic Principles

Enclosed watertight spaces (spaces below freeboard deck or within enclosed superstructures or deckhouses) are to be provided with means of draining. This may be achieved by connection to the bilge system or by gravity drain. In general, a gravity drain is permitted wherever the position of the space allows liquid to be discharged by gravity through an appropriate opening in the boundary of the space. Unless specifically stated (see 4-6-4/3.5.2 or the following paragraph), the discharge can be directed overboard or inboard. Where directed overboard, means are to be provided to prevent entry of sea water through the opening in accordance with 4-6-4/3.3. Where directed inboard, suitable arrangements are to be provided to collect and dispose of the drainage.

Non-watertight spaces (open superstructures or deckhouses) and open decks, where liquid can accumulate, are also to be provided with means of draining. In general, a gravity drain is permitted for all non-watertight spaces. All such drains are to be directed overboard.

Gravity drains are to be capable of draining the space when the vessel is on even keel and either upright or listed 5 degrees on either side.

In addition to the requirements identified below, for chemical carriers see 5C-9-2/3 and for passenger vessels see 5C-7-5/11.3.2.

3.3 Protection from Sea Water Entry

3.3.1 Overboard Gravity Discharges – Normally Open

3.3.1(a) *General*. Gravity discharge pipes led overboard from any watertight space are to be fitted with an effective and accessible means, as described below, to prevent backflow of water from the sea into that space. The requirements for non-return valves in this subparagraph are applicable only to those discharges which remain open during the normal operation of the vessel.

Normally, each separate discharge is to have one automatic non-return valve with a positive means of closing it from a position above the freeboard deck. The means for operating the positive closing valve is to be readily accessible and provided with an indicator showing whether the valve is open or closed. Alternatively, one automatic non-return valve and one positive closing valve controlled from above the freeboard deck may be accepted.

Where, however, the vertical distance from the summer load waterline (or, where assigned, timber summer load waterline) to the inboard end of the discharge pipe exceeds $0.01L_f$ (where L_f is the freeboard length of the vessel, as defined in 3-1-1/3.3), the discharge may have two automatic non-return valves without positive means of closing, provided that the inboard non-return valve is always accessible for examination under all service conditions, that is, above the tropical load waterline (or, where assigned, timber tropical load waterline.) If this is impracticable, a locally operated positive closing valve may be provided between the two non-return valves, in which case, the inboard non-return valve need not be located above the specified tropical load waterline.

Where the vertical distance from the summer load waterline to the inboard end of the discharge pipe exceeds $0.02L_p$, a single automatic non-return valve without positive means of closing is acceptable, provided it is located above the tropical load waterline (or, where assigned, timber tropical load waterline.) If this is impracticable, a locally operated positive closing valve may be provided below the single non-return valve, in which case, the non-return valve need not be located above the specified tropical load waterline.

3.3.1(b) *Manned Machinery Space*. Where sanitary discharges and scuppers lead overboard through the shell in way of manned machinery spaces, the fitting to the shell of a locally operated positive closing valve, together with a non-return valve inboard, will be acceptable.

See 4-6-4/Figure 1 for the acceptable arrangements of scuppers, inlets and discharges.

FIGURE 1
Overboard Discharges – Valve Requirements

Discharges coming from enclosed spaces below the freeboard deck or on the freeboard deck			Discharges coming from other spaces		
General requirement where inboard end < 0.01L above SWL	Discharges through manned machinery space	Alternatives where inboard end		outboard end > 450 mm below FB deck or < 600 mm above SWL	otherwise
		> 0.01L above SWL	> 0.02L above SWL		
Superstructure or Deckhouse Deck FB Deck SWL 	FB Deck SWL 	FB Deck SWL 	FB Deck SWL 	FB Deck SWL 	FB Deck SWL
Symbols: ▽ inboard end of pipes ↘ outboard end of pipes ↘ pipes terminating on the open deck ○ non return valve without positive means of closing ○/ non return valve with positive means of closing controlled locally ⊗ valve controlled locally T remote control normal thickness substantial thickness					

3.3.2 Overboard Gravity Discharges – Normally Closed

For overboard discharges which are closed at sea, such as gravity drains from topside ballast tanks, a single screw down valve operated from above the freeboard deck is acceptable.

3.3.3 Overboard Gravity Discharges from Spaces below the Freeboard Deck on Vessels Subject to SOLAS Requirements

For vessels subject to SOLAS requirements, instead of the requirements identified in 4-6-4/3.3.1 above, each separate gravity discharge led through the shell plating from spaces below the freeboard deck is to be provided with either one automatic non-return valve fitted with a positive means of closing it from above the freeboard deck or with two automatic non-return valves without positive means of closing, provided that the inboard valve is situated above the deepest subdivision load line (DSL) and is always accessible for examination under service conditions. Where a valve with positive means of closing is fitted, the operating position above the freeboard deck shall always be readily accessible and means shall be provided for indicating whether the valve is open or closed.

FIGURE 2
SOLAS Vessels – Overboard Discharges from Spaces below
Freeboard Deck – Valve Requirements

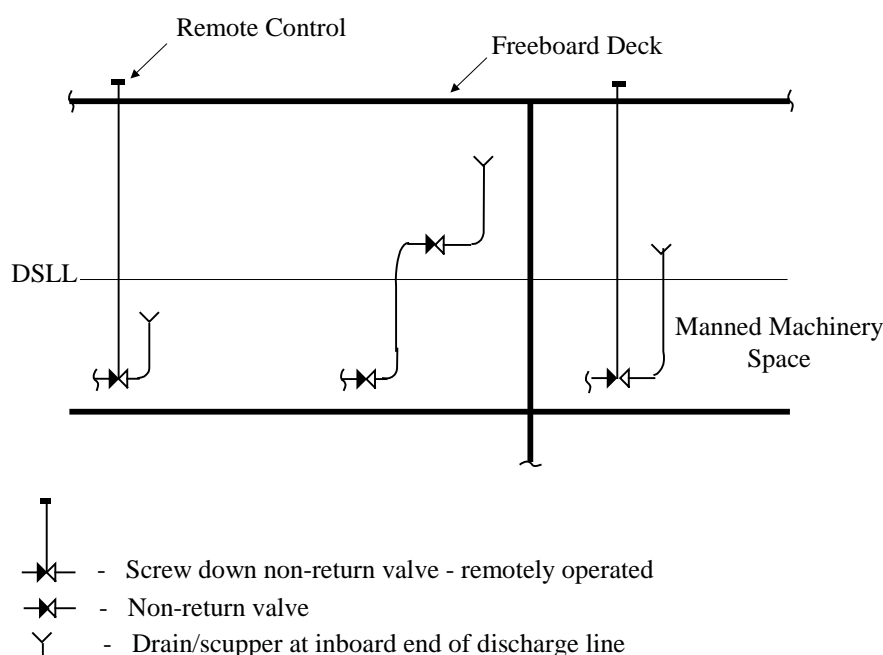

3.3.4 Scuppers and Discharges below the Freeboard Deck – Shell Penetration

Scuppers and discharge pipes originating at any level and penetrating the shell either more than 450 mm (17.5 in.) below the freeboard deck or less than 600 mm (23.5 in.) above the summer load waterline are to be provided with a non-return valve at the shell. This valve, unless required above may be omitted if the length of piping from the shell to freeboard deck has a wall thickness in accordance with 4-6-2/9.13.3.

3.3.5 Required Minimum Wall Thicknesses for Pipes

For pipes in the gravity drain systems covered by 4-6-4/3.3, the wall thickness of steel piping is not to be less than given below:

3.3.5(a) Piping where Substantial Thickness is Required. For scupper and discharge pipes between hull plating and the closeable or non-return valve, where substantial thickness is required:

- i) External diameter of pipes equal to or less than 80 mm (3.15 in.): thickness not less than 7.0 mm (0.276 in.)
- ii) External diameter of pipes 180 mm (7.1 in.): thickness not less than 10.0 mm (0.394 in.)
- iii) External diameter of pipes equal to or more than 220 mm (8.7 in.): thickness not less than 12.5 mm (0.5 in.)

Intermediate sizes are to be determined by linear interpolation.

3.3.5(b) Piping where Substantial Thickness is not Required. For scupper and discharge pipes inboard of a closeable or non-return valve, where substantial thickness is not required:

- i) External diameter of pipes equal to or less than 155 mm (6.1 in.): thickness not less than 4.5 mm (0.177 in.)
- ii) External diameter of pipes equal to or more than 230 mm (9.1 in.): thickness not less than 6.0 mm (0.236 in.)

Intermediate sizes are to be determined by linear interpolation.

3.5 Gravity Drains of Cargo Spaces on or Above Freeboard Deck

3.5.1 Overboard Drains

Enclosed cargo spaces of a vessel, whose summer freeboard is such that the deck edge of the cargo spaces being drained is not immersed when the vessel heels 5 degrees, may be drained by means of a sufficient number of suitably sized gravity drains discharging directly overboard. These drains are to be fitted with protection complying with 4-6-4/3.3.

3.5.2 Inboard Drains

Where the summer freeboard is such that the deck edge of the cargo space being drained is immersed when the vessel heels 5 degrees, the drains from these enclosed cargo spaces are to be led to a suitable space, or spaces, of adequate capacity, having a high water level alarm and provided with fixed pumping arrangement for discharge overboard. In addition, the system is to be designed such that:

- i) The number, size and disposition of the drain pipes are to prevent unreasonable accumulation of free water;
- ii) The pumping arrangements are to take into account the requirements for any fixed pressure water-spraying fire-extinguishing system;
- iii) Water contaminated with substances having flash point of 60°C (140°F) or below is not to be drained to machinery spaces or other spaces where sources of ignition may be present; and
- iv) Where the enclosed cargo space is protected by a fixed gas fire-extinguishing system, the drain pipes are to be fitted with means to prevent the escape of the smothering gas. The U-tube water seal arrangement should not be used due to possible evaporation of water and the difficulty in assuring its effectiveness.

3.5.3 Cargo Spaces Fitted with Fixed Water-spray System

Where the cargo space is fitted with a fixed water-spray fire extinguishing system, the drainage arrangements are to be such as to prevent the build-up of free surfaces. If this is not possible, the adverse effects upon stability of the added weight and free surface of water are to be taken into account for the approval of the stability information. See 4-7-2/7.3.1 and 4-7-2/7.3.9.

3.7 Gravity Drains of Spaces Other than Cargo Spaces

3.7.1 Gravity Drains Terminating in Machinery Space

Watertight spaces such as a steering gear compartment, accommodations, voids, etc. may be drained to the main machinery space; all such drains are to be fitted with a valve operable from above the freeboard deck or a quick-acting, self-closing valve. The valve is to be located in an accessible and visible location and preferably in the main machinery spaces.

3.7.2 Gravity Drains Terminating in Cargo Holds

When gravity drains from other spaces are terminated in cargo holds, the cargo hold bilge well is to be fitted with high level alarm.

3.7.3 Gravity Drains Terminating in a Drain Tank

Where several watertight compartments are drained into the same drain tank, each drain pipe is to be provided with a stop-check valve.

3.7.4 Escape of Fire Extinguishing Medium

Gravity drains which terminate in spaces protected by fixed gas extinguishing systems are to be fitted with means to prevent the escape of the extinguishing medium. See also 4-6-4/3.5.2.

3.9 Gravity Drains of Non-watertight Spaces

3.9.1 General

Scuppers leading from open deck and non-watertight superstructures or deckhouses are to be led overboard. The requirements of 4-6-4/3.3.4 also apply.

3.9.2 Helicopter Decks

Drainage piping of helicopter decks is to be constructed of steel. The piping is to be independent of any other piping system and is to be led directly overboard close to the waterline. The drain is not to discharge onto any part of the vessel.

3.11 Vessels Subject to Damage Stability

Gravity drain piping where affected by damage stability considerations is to meet 4-6-4/5.5.12.

3.13 Vessels Receiving Subdivision Loadlines

For vessel receiving subdivision loadlines, the bulkhead deck is to apply to provisions given in 4-6-4/3.3 when it is higher than the freeboard deck.

5 Bilge System

5.1 General

5.1.1 Application

The provisions of 4-6-4/5 apply to bilge systems serving propulsion and other machinery spaces, dry cargo spaces and spaces where accumulation of water is normally expected. Additional requirements for bilge systems of specialized vessels such as oil carriers, passenger vessels, etc. are provided in Part 5C and Part 5D.

5.1.2 Basic Principles

5.1.2(a) Function. A bilge system is intended to dispose of water which may accumulate in spaces within the vessel due to condensation, leakage, washing, fire fighting, etc. It is to be capable of controlling flooding in the propulsion machinery space as a result of limited damage to piping systems.

5.1.2(b) Cross-flooding prevention. The system is to be designed to avoid the possibility of cross-flooding between spaces and between the vessel and the sea.

5.1.2(c) System availability. To enhance system availability, bilge pump integrity is to be assured through testing and certification; at least two bilge pumps are to be provided, and bilge suction control valves are to be accessible for maintenance at all times.

5.1.2(d) Oil pollution prevention. Provision is to be made to process oily bilge water prior to discharging overboard.

5.3 Bilge System Sizing

5.3.1 Size of Bilge Suctions

The minimum internal diameter of the bilge suction pipes is to be determined by the following equations, to the nearest 6 mm (0.25 in.) of the available commercial sizes.

5.3.1(a) Bilge main. The diameter of the main bilge line suction is to be determined by the following equations:

$$d = 25 + 1.68\sqrt{L(B + D)} \text{ mm} \qquad d = 1 + \sqrt{\frac{L(B + D)}{2500}} \text{ in.}$$

where

- d = internal diameter of the bilge main pipe; mm (in.)
- L = scantling length of vessel, as defined in 3-1-1/3.1; m (ft); see also 4-6-4/5.3.1(b)
- B = breadth of vessel, as defined in 3-1-1/5; m (ft)
- D = depth to bulkhead or freeboard deck, as defined in 3-1-1/7.1; m (ft); see also 4-6-4/5.3.1(e).

However, no internal diameter bilge main suction pipe is to be less than listed below.

Vessel Length	Minimum Pipe Size (I.D.)
30.5 m (100 ft) in length or greater	63 mm (2.5 in.)
20 m (65 ft) or greater but below 30.5 m (100 ft)	38 mm (1.5 in.)
Below 20 m (65 ft)	25 mm (1 in.)

5.3.1(b) *Bilge system serving only engine room.* Where the engine room bilge pumps are fitted primarily for serving the engine room and they do not serve cargo space bilges, L may be reduced by the combined length of the cargo tanks or cargo holds. In such cases, the cross sectional area of the main bilge line is not to be less than twice the required cross sectional area of the engine room branch bilge lines.

5.3.1(c) *Direct bilge suction.* The diameter of the direct bilge suction [see 4-6-4/5.5.5(a)] is to be not less than that determined by the equation in 4-6-4/5.3.1(a).

5.3.1(d) *Bilge branch.* The diameter of the bilge branch suction for a compartment is to be determined by the following equation. If the compartment is served by more than one branch suction, the combined area of all branch suction pipes is not to be less than the area corresponding to the diameter determined by the following equations:

$$d_B = 25 + 2.16\sqrt{c(B + D)} \text{ mm} \qquad d_B = 1 + \sqrt{\frac{c(B + D)}{1500}} \text{ in.}$$

where

- d_B = internal diameter of the bilge branch pipe; mm (in.)
- c = length of the compartment; m (ft)

However, no branch suction pipe needs to be more than 100 mm (4 in.) internal diameter, nor is to be less than 50 mm (2 in.) internal diameter, except that for pumping out small pockets or spaces, 38 mm (1.5 in.) internal diameter pipe may be used.

5.3.1(e) *Enclosed cargo space on bulkhead deck.* For calculating the bilge main diameter of vessels having enclosed cargo spaces on the bulkhead deck or the freeboard deck, which is drained inboard by gravity in accordance with 4-6-4/3.5.2 and which extends for the full length of the vessel, D is to be measured to the next deck above the bulkhead or freeboard deck. Where the enclosed cargo space covers a lesser length, D is to be taken as a molded depth to the freeboard deck plus $\ell h/L$, where ℓ and h are aggregate length and height, respectively, of the enclosed cargo space.

5.3.1(f) *Bilge common-main.* The diameter of each common-main bilge line may be determined by the equation for bilge branches given in 4-6-4/5.3.1(d) using the combined compartment length upstream of the point where the diameter is being determined. In case of double hull construction with full depth wing tanks served by a ballast system, where the beam of the vessel is not representative of the breadth of the compartment, B , may be appropriately modified to the breadth of the compartment. However, no common-main bilge pipe needs to be more than the diameter for the bilge main given in 4-6-4/5.3.1(a).

5.3.2 Bilge Pump Capacity

5.3.2(a) *Vessels with length 45.7 m (150 ft) and above.* For vessels with length 45.7 m (150 ft) and greater, when only two bilge pumps are fitted, each is to be capable of giving a speed of water through the bilge main required by 4-6-4/5.3.1(a) of not less than 2 m (6.6 ft) per second. The minimum capacity Q of the required bilge pump may be determined from the following equation:

$$Q = \frac{5.66d^2}{10^3} \text{ m}^3/\text{hr} \qquad Q = 16.1d^2 \text{ gpm}$$

5.3.2(b) *Vessels with length below 45.7 m (150 ft).* For vessels with length below 45.7 m (150 ft), the capacity of each pump is to be in accordance with the following table:

Vessel Length	Minimum Capacity per Pump
30.5 m (100 ft) or greater but below 45.7 m (150 ft)	$Q = 14.33 \text{ m}^3/\text{hr}$ (66.6 gpm)
20 m (65 ft) or greater but below 30.5 m (100 ft)	$Q = 11.36 \text{ m}^3/\text{hr}$ (50 gpm)
Below 20 m (65 ft) One fixed power driven pump, which may be an attached unit, and one portable hand pump.	$Q = 5.5 \text{ m}^3/\text{hr}$ (25 gpm) Hand pump: 5 gpm, 1.13 m ³ /hr

where

- Q = power driven pump capacity
- d = the required internal diameter, mm (in.), of the bilge main as defined in 4-6-4/5.3.1(a).

When more than two pumps are connected to the bilge system, their arrangement and aggregate capacity are not to be less effective.

5.5 Bilge System Design

5.5.1 General

All vessels are to be fitted with an efficient bilge pumping system. The system is to meet the basic principles of 4-6-4/5.1.2, and be capable of pumping from and draining any watertight compartment other than spaces permanently used for carriage of liquids and for which other efficient means of pumping are provided. Non-watertight compartments liable to accumulate water, such as chain lockers, non-watertight cargo holds, etc., are also to be provided with an efficient bilge pumping system.

A gravity drain system, in lieu of a bilge pumping system, may be accepted subject to the provisions of 4-6-4/3 above.

Bilge pumping systems are to be capable of draining the spaces when the vessel is on even keel and either upright or listed 5 degrees on either side.

5.5.2 Bilge Pumps

5.5.2(a) *Number of pumps.* At least two power driven bilge pumps are to be provided, one of which may be driven by the propulsion unit. Bilge pump capacity is to be in accordance with 4-6-4/5.3.2.

5.5.2(b) *Permissible use of other pumps.* Sanitary, ballast and general service pumps may be accepted as independent power bilge pumps, provided they are of required capacity, not normally used for pumping oil, and are appropriately connected to the bilge system.

5.5.2(c) *Priming.* Where centrifugal pumps are installed, they are to be of the self-priming type or connected to a priming system. However, pumps used for emergency bilge suction [see 4-6-4/5.5(b)] need not be of the self-priming type.

5.5.2(d) *Test and certification.* Bilge pumps are to be certified in accordance with 4-6-1/7.3.

5.5.3 Strainers

Bilge lines in machinery spaces other than emergency suction spaces are to be fitted with strainers, easily accessible from the floor plates, and are to have straight tail pipes to the bilges. The ends of the bilge lines in other compartments are to be fitted with suitable strainers having an open area of not less than three times the area of the suction pipe.

5.5.4 Bilge Piping System – General

5.5.4(a) Bilge manifolds and valves. Bilge manifolds and valves in connection with bilge pumping are to be located in positions which are accessible at all times for maintenance under ordinary operating conditions. All valves at the manifold controlling bilge suction from the various compartments are to be of the stop-check type. In lieu of a stop-check valve, a stop valve and a non-return valve may be accepted.

5.5.4(b) Main control valves. Where a bilge pump is connected for bilge, ballast and other sea water services, the bilge suction main, the ballast suction main, etc. are each to be provided with a stop valve, so that when the pump is used for one service, the other services can be isolated.

5.5.4(c) Bilge piping passing through tanks. Where passing through deep tanks, unless being led through a pipe tunnel, bilge suction lines are to be of steel having a thickness at least as required by column D of 4-6-2/Table 4. Pipes of other materials having dimensions properly accounting for corrosion and mechanical strength may be accepted. The number of joints in these lines is to be kept to a minimum. Pipe joints are to be welded or heavy flanged (e.g., one pressure rating higher). The line within the tank is to be installed with expansion bends. Slip joints are not permitted. A non-return valve is to be fitted at the open end of the bilge line. These requirements are intended to protect the space served by the bilge line from being flooded by liquid from the deep tank in the event of a leak in the bilge line.

5.5.4(d) Arrangement of suction pipes. For drainage when the vessel is listed (see 4-6-4/5.5.1), wing suction will often be necessary, except in narrow compartments at the ends of the vessel. Arrangements are to be made whereby water in the compartment will drain to the suction pipe.

5.5.5 Requirements for Propulsion Machinery Space

5.5.5(a) Direct bilge suction. One of the required independently driven bilge pumps is to be fitted with a suction led directly from the propulsion machinery space bilge to the suction main of the pump, so arranged that it can be operated independently of the bilge system. The size of this line is not to be less than that determined by 4-6-4/5.3.1(c). The direct bilge suction is to be controlled by a stop-check valve.

If watertight bulkheads separate the propulsion machinery space into compartments, a direct bilge suction is to be fitted from each compartment, unless the pumps available for bilge service are distributed throughout these compartments. In such a case, at least one pump with a direct suction is to be fitted in each compartment.

5.5.5(b) Emergency bilge suction. In addition to the direct bilge suction required by 4-6-4/5.5.5(a), an emergency bilge suction is to be fitted for the propulsion machinery space. The emergency bilge suction is to be directly connected to the largest independently driven pump in the propulsion machinery space, other than the required bilge pumps. Where this pump is not suitable, the second largest suitable pump in the propulsion machinery space may be used for this service, provided that the selected pump is not one of the required bilge pumps and its capacity is not less than that of the required bilge pump.

The emergency bilge line is to be provided with a suction stop-check valve, which is to be so located as to enable rapid operation, and a suitable overboard discharge line. For the emergency bilge inlet, the distance between the open end of the suction inlet and the tank top is to be adequate to allow a full flow of water. The hand wheel of the emergency bilge suction valve is to be positioned not less than 460 mm (18 in.) above the floor plates.

In addition, the following arrangements are also to be complied with, as applicable:

- i) For internal-combustion-engine propulsion machinery spaces, the area of the emergency bilge suction pipe is to be equal to the full suction inlet of the pump selected.

- ii) For steam propulsion machinery spaces, the main cooling water circulating pump is to be the first choice for the emergency bilge suction, in which case, the diameter of the emergency bilge suction is to be at least two-thirds the diameter of the cooling water pump suction.

5.5.5(c) *Centralized or unattended operation.* Where the propulsion machinery space is intended for centralized or unattended operation (**ACC/ACCU** or **ABCU** notation), a high bilge water level alarm system is to be fitted, see 4-9-5/15.3. As a minimum, bilge valve controls are to be located above the floor grating, having regard to the time likely to be required in order to reach and operate the valves.

5.5.6 Requirements for Small Compartments

Small compartments, such as chain lockers, echo sounder spaces and decks over peak tanks, etc., may be drained by ejectors or hand pumps. Where ejectors are used for this purpose, the overboard discharge arrangements are to comply with 4-6-4/3.3.

5.5.7 Common-main Bilge Systems

A common-main bilge system normally consists of one or more main lines installed along the length of the vessel fitted with branch bilge suction connections to various compartments. Where only one fore-aft bilge main is installed, the bilge main is to be located inboard of 20% of the molded beam of the vessel, measured inboard from the side of the ship, perpendicular to the centerline at the level of the summer load line. If there is at least one bilge main on each side of the vessel, then these bilge mains may be installed within 20% of the molded beam measured inboard from the side of the ship, perpendicular to the centerline at the level of the summer load line. In such cases, piping arrangements are to be such that it is possible to effectively pump out all compartments using the main on either side of the vessel.

For single common-main bilge systems, the control valves required in the branches from the bilge main are to be accessible at all times for maintenance. This accessibility is not required for multiple common-main bilge systems arranged such that any single control valve failure will not disable the bilge pumping capability from any one space. In all cases, control valves are to be of the stop-check type with remote operators. Remote operators may be controlled from a manned machinery space, or from an accessible position above the freeboard deck, or from under deck walkways. Remote operators may be of hydraulic, pneumatic, electric or reach rod type.

5.5.8 Cargo Spaces of Combination Carriers

For combination carriers, such as oil-or-bulk carriers, arrangements are to be made for blanking off the oil and ballast lines and removing the blanks in the bilge lines when dry or bulk cargo is to be carried. Conversely, the bilge lines are to be blanked-off when oil or ballast is to be carried.

5.5.9 Cargo Spaces Intended to Carry Dangerous Goods

The following requirements apply to cargo spaces intended to carry dangerous goods as defined in 4-7-1/11.25.

5.5.9(a) *Independent bilge system.* A bilge system, independent of the bilge system of the machinery space and located outside the machinery space, is to be provided for cargo spaces intended to carry flammable liquids with a flash point of less than 23°C or toxic liquids. The independent bilge system is to comply with the provisions of 4-6-4/5, including the provision of at least two bilge pumps. The space containing the independent bilge pumps is to be independently ventilated, giving at least six air changes per hour. This, however, does not apply to eductors located in cargo space.

5.5.9(b) *Combined bilge system.* As an alternative to 4-6-4/5.5.9(a) above, the cargo spaces may be served by the bilge system of the machinery space and an alternative bilge system. The alternative bilge system is to be independent of or capable of being segregated from the machinery space bilge system. The capacity of the alternative bilge system is to be at least 10 m³/h per cargo space served, but need not exceed 25 m³/h. This alternative bilge system need not be provided with redundant pumps. Whenever flammable liquids with flash point of less than 23°C or toxic liquids are carried in the cargo spaces, the bilge lines leading into the machinery space are to be blanked off or closed off by lockable valves. In addition, a warning notice to this effect is to be displayed at the location.

5.5.9(c) *Gravity drain system.* If the cargo spaces are drained by gravity, the drainage is to be led directly overboard or into a closed drain tank located outside machinery spaces. The drain tank is to be vented to a safe location on the open deck. Drainage from a cargo space to the bilge well of a lower cargo space is permitted only if both spaces satisfy the same requirements.

5.5.10 Cargo Spaces Fitted with Fixed Water-spray System

Where the cargo space is fitted with a fixed water-spray fire extinguishing system, the drainage arrangements are to be such as to prevent the build-up of free surfaces. If this is not possible, the adverse effect upon stability of the added weight and free surface of water are to be taken into account for the approval of the stability information. See 4-7-2/7.3.1 and 4-7-2/7.3.9.

5.5.11 Bilge Suctions for Normally Unmanned Spaces

Normally, unmanned spaces located below the waterline, such as bow thruster compartment, emergency fire pump room, etc., for which bilge pumping is required, are to be arranged such that bilge pumping can be effected from outside the space, or alternatively, a bilge alarm is to be provided.

5.5.12 Vessels Subject to Damage Stability

Bilge pipes installed within the regions of assumed damage under damage stability conditions are to be considered damaged. Bilge piping will affect damage stability considerations if:

- It is installed within the extent of assumed damage in damage stability consideration, and
- The damage to such bilge piping will lead to progressive flooding of intact spaces through open ends in the bilge piping system.

Affected bilge piping is to be fitted with non-return valves in the lines in the intact spaces to prevent the progressive flooding of these spaces. The valves will not be required if it can be shown that, even with the progressively flooded spaces taken into consideration, the vessel still complies with the applicable damage stability criteria.

5.5.13 Cargo Spaces With Non-watertight Hatches Intended to Carry Containers

Where cargo holds are used solely for the transport of containers and for which hatch covers weathertight gaskets have been dispensed with [see 3-2-15/9.19.2(b)], a bilge alarm system is to be provided.

5.5.13(a) *Bilge Level.* The cargo holds are to be provided with two independent systems to detect excessive rise of bilge water in the bilges or bilge wells. The arrangements including the number of sensors and locations are to be such that accumulation of bilge water may be detected at the various angles of vessel's heel and trim. The alarm is to be given in the centralized control station.

5.5.13(b) *Bilge Pump.* Where the bilge pumps are arranged for automatic operation, means are to be provided to indicate, at the centralized control station, when the pump is operating more frequently than would normally be expected, or when the pump is operating for an excessive length of time.

5.7 Oil Pollution Prevention Measures

5.7.1 General

For vessels of 400 gross tons and above, means are to be provided to process oil contaminated water from machinery space bilges prior to discharging it overboard. In general, the discharge criteria of MARPOL ANNEX 1, Regulation 15 are to be complied with.

5.7.2 Oily Water Filtering or Separating Equipment

Oily water filtering equipment capable of processing oily mixtures to produce an effluent with oil content not exceeding 15 parts per millions (PPM) and complying with IMO Resolution MEPC.107(49) is to be provided to allow oily water from the bilges to be processed prior to discharging overboard. For vessels of 10,000 tons gross tonnage and above, the equipment is to be fitted with an alarm and an arrangement to automatically stop the discharge when 15 PPM cannot be maintained.

5.7.3 Sludge Tank

A tank or tanks of adequate capacity is to be provided to receive oily residues such as those resulting from the oily water filtering or separating equipment and from the purification of fuel and lubricating oils. The minimum sludge tank capacity V_1 is to be calculated by the following formula:

$$V_1 = K_1 CD \quad \text{m}^3 \text{ (ft}^3\text{)}$$

where

- K_1 = 0.015 for vessels where heavy fuel oil is purified for main engine use or
 = 0.005 for vessels using diesel oil or heavy fuel oil which does not require purification before use
- C = daily fuel oil consumption, $\text{m}^3 \text{ (ft}^3\text{)}$
- D = maximum period of voyage between ports where sludge can be discharged ashore (days). In the absence of precise data, a figure of 30 days is to be used.

The sludge tank is to be so designed as to facilitate cleaning. Where heavy fuel oil residue is expected to be received by the sludge tank, heating arrangements are to be provided to facilitate the discharge of the sludge tank.

5.7.4 Sludge Piping System

5.7.4(a) *Sludge pump.* The sludge tank is to be provided with a designated pump of a suitable type, capacity and discharge head for the discharge of the tank content to shore reception facilities.

5.7.4(b) *Standard discharge connection.* To enable the discharge of sludge to shore reception facilities, the sludge piping is to be provided with a standard discharge connection, in accordance with 4-6-4/Table 1.

TABLE 1
Dimensions and Details of Standard Discharge Connection Flange

	<i>Dimension</i>
Outside diameter	215 mm
Inner diameter	According to pipe outside diameter
Bolt circle diameter	183 mm
Slots in flange	6 holes 22 mm in diameter equidistantly placed on a bolt circle of the above diameter, slotted to the flange periphery. The slot width to be 22 mm
Flange thickness	20 mm
Bolts and nuts:	6 sets, each of 20 mm in diameter and of suitable length
The flange is designed to accept pipes up to a maximum internal diameter of 125 mm and is to be of steel or other equivalent material having a flat face. This flange, together with a gasket of oil-proof material, is to be suitable for a service pressure of 6 kg/cm ²	

5.7.4(c) *Sludge piping.* There are to be no discharge connections from the sludge piping system to the bilge system, except that:

- The sludge tank discharge piping and bilge-water piping may be connected to a common piping leading to the standard discharge connection referred to in 4-6-4/5.7.4(b) provided the connection of both systems does not allow the transfer of sludge to the bilge system.
- The sludge tank may be fitted with drains, with manually operated self-closing valves and arrangements for subsequent visual monitoring of the settled water, that lead to an oily bilge water holding tank or bilge well, or an alternative arrangement, provided such arrangement does not connect directly to the bilge discharge piping system.

Piping to and from sludge tanks is to have no direct connection overboard other than the standard discharge connection referred to in 4-6-4/5.7.4(b).

5.9 Testing and Trials

The bilge system is to be tested under working conditions, see 4-6-2/7.3.3. See also 3-7-2/3 for bilge system trials.

7 Ballast Systems

7.1 General

7.1.1 Application

These requirements apply to ballast systems for all vessels. For additional ballast system requirements for oil carriers, see Part 5C.

7.1.2 Basic Principles

These requirements are intended to provide a reliable means of pumping and draining ballast tanks through the provision of redundancy and certification of ballast pumps, and the provision of suitable remote control, where fitted.

7.3 Ballast Pumps

For self-propelled vessels 20 m (65 ft) in length or greater, all ballast tanks are to be connected to at least two power driven ballast pumps, one of which may be driven by the propulsion unit. Sanitary, bilge and general service pumps may be accepted as independent power ballast pumps. Alternative means of deballasting, such as an eductor or a suitable liquid cargo pump with an appropriate temporary connection to the ballast system [see 5C-1-7/5.3.1(c)], may be accepted in lieu of a second ballast pump.

Ballast pumps are to be certified in accordance with 4-6-1/7.3.

7.5 Ballast Piping and Valves

7.5.1 Ballast Tank Valves

Valves controlling flow to ballast tanks are to be arranged so that they will remain closed at all times except when ballasting. Where butterfly valves are used, they are to be of a type with positive holding arrangements, or equivalent, that will prevent movement of the valve position due to vibration or flow of fluids.

7.5.2 Remote Control Valves

Remote control valves, where fitted, are to be arranged so that they will close and remain closed in the event of loss of control power. Alternatively, the remote control valves may remain in the last ordered position upon loss of power, provided that there is a readily accessible manual means to close the valves upon loss of power.

Remote control valves are to be clearly identified as to the tanks they serve and are to be provided with position indicators at the ballast control station.

7.5.3 Vessels Subject to Damage Stability

Ballast pipes installed in the regions of assumed damage under damage stability consideration are to be considered damaged. Ballast piping will affect damage stability considerations if:

- It is installed within the extent of assumed damage in damage stability consideration, and
- The damage to the ballast pipe will lead to progressive flooding of intact ballast tanks through open ends in the ballast piping system.

Affected ballast piping is to be fitted with valves in the pipes in the intact tanks to prevent progressive flooding of these tanks. The valves are to be of a positive closing type and operable from above the freeboard deck or from a manned machinery space. Where the valves are electrically, hydraulically or pneumatically actuated, the cables or piping for this purpose are not to be installed within the extent of assumed damage, or, alternatively, the valves are to be arranged to fail in the closed position upon loss of control power.

The valves will not be required if it can be shown that, even with the progressively flooded spaces taken into consideration, the vessel still complies with the applicable damage stability criteria.

7.5.4 Ballast Pipes Passing Through Fuel Oil Tanks

To minimize cross-contamination, where passing through fuel oil tanks, unless being led through pipe tunnel, ballast lines are to be of steel or equivalent [see 4-6-4/5.5.4(c)] having a thickness at least as required by column D of 4-6-2/Table 4. The number of joints in these lines is to be kept to a minimum. Pipe joints are to be welded or heavy flanged (e.g., one pressure rating higher). The line within the tank is to be installed with expansion bends. Slip joints are not permitted.

7.7 Ballast Water Treatment Systems

Where a ballast water treatment system is to be installed, it is to comply with the requirements in Sections 4 and 5 of the *ABS Guide for Ballast Water Treatment* and the same is to be verified by ABS.

9 Tank Vents and Overflows

9.1 General

9.1.1 Application

These requirements apply to vents and overflows of liquid and void tanks. Tanks containing flammable liquids, such as fuel oil and lubricating oil, are subject to additional requirements, which are provided in this subsection. For hydraulic oil, see also 4-6-7/3.3.2. Vents and overflows, and inerting systems, as applicable, for liquid cargo tanks are provided in Part 5C of the Rules.

Ventilators installed for ventilation of normally dry compartments, such as steering gear compartment, cargo hold, etc., are to comply with the provisions of 3-2-17/9.1.

9.1.2 Basic Requirements

9.1.2(a) Purposes of vents. All tanks served by pumps are to be provided with vents. Primarily, vents allow air or vapor from within the tank to escape when the tank is being filled, and take in air when the tank is being discharged. Vents are also needed for tanks in the storage mode to allow them to 'breathe'. In general, vents are to be fitted at the highest point of the tanks so that venting can be achieved effectively.

9.1.2(b) Purposes of overflows. Tanks filled by a pumping system may, in addition to vents, be fitted with overflows. Overflows prevent overpressurization of a tank if it is overfilled and also provide for safe discharge or disposal of the overflowing liquid. Overflows may also be fitted to limit the level at which a tank may be filled. Overflows are to be sized based on the capacity of the pump and the size of the filling line. Considerations are to be given to receiving the overflow.

9.1.2(c) Combining vents and overflows. Vents may also act as overflows provided all the requirements applicable to both vents and overflows are complied with.

9.1.2(d) Termination of the outlet ends of vents and overflows. Generally, vents emanating from tanks containing liquids likely to evolve flammable or hazardous vapor are to have their outlets located in the open weather. Depending on the liquid contained in the tank, overflow outlets are to be located such that they either discharge overboard or into designated overflow tanks so as to avoid inadvertent flooding of internal spaces. Outlet ends of vents and overflows, where exposed to the weather, are to be provided with means to prevent sea water from entering the tanks through these openings.

9.1.2(e) *Small spaces.* Small voids which are not fitted with a permanent means of pumping out bilges, or through which no pressurized piping passes, may be exempted from being fitted with vents.

9.1.3 Vessels Subject to Damage Stability Requirements

Vents and overflows of vessels subject to damage stability requirements are to be terminated above the equilibrium water line in the damaged conditions. Automatic means of closure are to be fitted to the outlets of vents whose intersection with the deck is below the equilibrium water line. Such means are also required for those vents whose outlets will be submerged in the range of residual stability beyond the equilibrium where such range is required by the applicable damage stability criteria.

9.3 Tank Vents

9.3.1 General Requirements

Generally, each tank served by a pumping system, as indicated in 4-6-4/9.1.2, is to be fitted with at least two vents. Tanks with surface area less than $B^2/16$ (where B is the breadth of the vessel as defined in 3-1-1/5) may, however, be fitted with one vent. The vents are to be located as far apart as possible.

As far as practicable, the vent pipe is to be located at the highest point of the tank. This is to permit air, vapor and gas from all parts of the tank to have access to the vent pipe with the vessel at an upright position or at varying angles of heel and trim. Vent pipes are to be arranged to provide adequate drainage. No shutoff valve or closing device that can prevent the venting from a tank is to be installed in vent piping.

9.3.2 Vent Pipe Height and Wall Thickness

9.3.2(a) *Exposed to weather.* Vent pipes on decks exposed to the weather are to have the following heights:

760 mm (30 in.) for those on the freeboard deck; and

450 mm (17.5 in.) for those on the superstructure deck.

The height is to be measured from the deck to the point where water may have access below. Where these heights may interfere with the working of the vessel, a lower height may be accepted, provided ABS is satisfied that the closing arrangements and other circumstances justify a lower height.

The wall thicknesses of vent pipes where exposed to the weather are to be not less than that specified below. For vent pipes located on the fore deck, as defined in 3-2-17/9.7.1, the strength and wall thickness requirements are to also comply with 3-2-17/9.7.2 and 3-2-17/9.7.3:

Nominal Size, d	Min. Wall Thickness
$d \leq 65$ mm (2.5 in.)	6.0 mm (0.24 in.)
65 mm (2.5 in.) $< d < 150$ mm (6 in.)	by interpolation ⁽¹⁾
$d \geq 150$ mm (6 in.)	8.5 mm (0.33 in.)

Note:

$$1 \quad 6 + 0.029(d - 65) \text{ mm or } 0.24 + 0.026(d - 2.5) \text{ in.}$$

9.3.2(b) *Not exposed to weather.* Vent pipes not exposed to the weather need not comply with the height and wall thickness required by 4-6-4/9.3.2(a). However, vent pipes passing through fuel oil or ballast tanks are to have wall thicknesses not less than that indicated in column D of 4-6-2/Table 4. Other vent pipes are to meet thickness requirements of column C of the same table.

9.3.3 Vent Pipe Size

9.3.3(a) *Minimum size.* The minimum internal diameter of vent pipes is to be as follows:

Tank	Minimum Internal Diameter, mm (in.)
Water tanks	50 (2) *
Oil tanks	65 (2.5)

* *Note:* For vessels with length, *L*, (as defined in 3-1-1/3.1) 80 meters (263 feet) and greater Minimum diameter of vent pipes on fore deck not to be less than 65 mm. See 3-2-17/9.7.3(b).

where water tanks refer to freshwater and sea water tanks; oil tanks refer to fuel oil, lubricating oil, hydraulic oil and other oil tanks. Small water or oil tanks of less than 1 m³ (36 ft³) may have vent pipe of 38 mm (1.5 in.) minimum internal diameter.

9.3.3(b) *Vent sizing.* Where a separate overflow is not fitted, the aggregate area of the vent pipe(s) provided for the tank is to be at least 125% of the effective area of the filling line.

Where overflow pipe(s) are fitted, and the aggregate area of the overflow pipes is at least 125% of the effective area of the filling line, in such cases, vent pipes need not exceed the minimum sizes in 4-6-4/9.3.3(a).

Where high capacity or high head pumps are used, calculations demonstrating the adequacy of the vent and overflow to prevent over- or underpressurization of the ballast tanks are to be submitted. See also 4-6-4/9.5.2.

9.3.4 Termination of Vent Pipe Outlets

9.3.4(a) *Termination on weather deck.* Outlets of vents from the following tanks are to be led to the weather:

- Ballast tanks
- Fuel-oil tanks, except fuel-oil drain tanks with a volume less than 2 m³ (70.6 ft³) and which cannot be filled by a pump – see 4-6-4/13.3.4
- Thermal oil tanks
- Tanks containing liquids having flash point of 60°C (140°F) or below
- Void tanks adjacent to tanks containing liquids having a flash point of 60°C or below

Where it is impracticable to terminate vents on a weather deck as required, such as the case of open car deck of a ro-ro vessel, vents may be led overboard from a deck below the weather deck. In such a case, non-return valves of an approved type are fitted at the outlets to prevent ingress of water. See also 4-6-4/9.5.3.

9.3.4(b) *Termination on or above freeboard deck.* Vent outlets from double bottom and other structural tanks, including void tanks, whose boundaries extend to the shell of the vessel at or below the deepest load waterline, are to be led above the freeboard deck. This is so that in the event of shell damage in way of these tanks the vent pipes will not act as a possible source of progressive flooding to otherwise intact spaces below the freeboard deck.

9.3.4(c) *Termination in machinery space.* Vents from tanks other than those stated in 4-6-4/9.3.4(a) and 4-6-4/9.3.4(b) may terminate within the machinery space, provided that their outlets are so located that overflow therefrom will not impinge on electrical equipment, cause a hazardous consequence such as fire, or endanger personnel.

9.3.5 Protection of Vent Outlets

9.3.5(a) *Protection from weather and sea water ingress.* All vents terminating in the weather are to be fitted with return bends (gooseneck), or equivalent, and the vent outlet is to be provided with an automatic means of closure i.e., close automatically upon submergence (e.g., ball float or equivalent) complying with 4-6-4/9.3.7.

9.3.5(b) *Protection for fuel oil tanks.* In addition to 4-6-4/9.3.5(a), vents from fuel oil tanks are to comply with the following:

- i) Vent outlets are to be fitted with corrosion resistant flame-screens. Either a single screen of corrosion-resistant wire of at least 12 by 12 mesh per linear cm (30 by 30 mesh per linear inch), or two screens of at least 8 by 8 mesh per linear cm (20 by 20 mesh per linear inch) spaced not less than 13 mm (0.5 inch) nor more than 38 mm (1.5 inch) apart are acceptable. The clear area through the mesh of the flame-screen is to be not less than the required area of the vent pipe specified in 4-6-4/9.3.3.

Note: Mesh count is defined as a number of openings in a linear cm (inch) counted from the center of any wire to the center of a parallel wire.

- ii) Vent outlets are to be situated where possibility of ignition of the gases issuing therefrom is remote.
- iii) Vents for fuel oil service and settling tanks directly serving the propulsion and generator engines are to be so located and arranged that in the event of a broken vent pipe, this will not directly lead to the risk of ingress of sea water splashes or rain water into the fuel oil tanks.

9.3.5(c) *Protection for lubricating oil tanks.* Vents for lubricating oil tanks directly serving propulsion and generator engines, where terminated on the weather deck are to be so located and arranged that in the event of a broken vent pipe, this will not directly lead to the risk of ingress of sea water splashes or rain water.

9.3.6 Oil Pollution Prevention

Vents from fuel oil and other oil tanks, which, in the event of an inadvertent overflow, may result in oil pollution of the marine environment, are to be fitted with overflow arrangements (see 4-6-4/9.5.5) or means of containment, such as a coaming, in way of vent outlets.

9.3.7 Vent Outlet Closing Devices

9.3.7(a) *General.* Where vent outlets are required by 4-6-4/9.3.5(a) to be fitted with automatic closing devices, they are to comply with the following:

9.3.7(b) *Design.*

- i) Vent outlet automatic closing devices are to be so designed that they will withstand both ambient and working conditions, and be suitable for use at inclinations up to and including $\pm 40^\circ$.
- ii) Vent outlet automatic closing devices are to be constructed to allow inspection of the closure and the inside of the casing, as well as changing the seals.
- iii) Efficient ball or float seating arrangements are to be provided for the closures. Bars, cage or other devices are to be provided to prevent the ball or float from contacting the inner chamber in its normal state and made in such a way that the ball or float is not damaged when subjected to water impact due to a tank being overfilled.
- iv) Vent outlet automatic closing devices are to be self-draining.
- v) The clear area through a vent outlet closing device in the open position is to be at least equal to the area of the inlet.
- vi) An automatic closing device is to:
 - Prevent the free entry of water into the tanks,
 - Allow the passage of air or liquid to prevent excessive pressure or vacuum developing in the tank.
- vii) In the case of vent outlet closing devices of the float type, suitable guides are to be provided to ensure unobstructed operation under all working conditions of heel and trim. [see 4-6-4/9.3.7(b)i]
- viii) The maximum allowable tolerances for wall thickness of floats should not exceed $\pm 10\%$ of thickness.

- ix) The inner and outer chambers of an automatic air pipe head is to be of a minimum thickness of 6 mm (0.24 inch). Where side covers are provided and their function is integral to providing functions of the closing device as outlined in 4-6-4/9.3.7(b)vi, they are to have a minimum wall thickness of 6 mm (0.24 inch). If the air pipe head can meet the tightness test in 4-6-4/9.3.7(d)i without the side covers attached, then the side covers are not considered to be integral to the closing device, in which case a wall less than 6 mm may be acceptable for side covers.

9.3.7(c) *Materials*

- i) Casings of vent outlet closing devices are to be of approved metallic materials adequately protected against corrosion.
- ii) For galvanized steel air pipe heads, the zinc coating is to be applied by the hot method and the thickness is to be 70 to 100 micrometers (2.756 to 3.937 mil).
- iii) For areas of the head susceptible to erosion (e.g. those parts directly subjected to ballast water impact when the tank is being pressed up, for example the inner chamber area above the air pipe, plus an overlap of 10° or more to either side) an additional harder coating should be applied. This is to be an aluminum bearing epoxy, or other equivalent coating, applied over the zinc.
- iv) Closures and seats made of non-metallic materials are to be compatible with the media intended to be carried in the tank and to seawater, and suitable for operating at ambient temperatures between -25°C and 85°C (-13°F and 185°F).

9.3.7(d) *Type Testing*

- i) *Testing of Vent Outlet Automatic Closing Devices.* Each type and size of vent outlet automatic closing device is to be type tested at the manufacturer's works or other acceptable location.

The minimum test requirements for a vent outlet automatic closing device are to include the determination of the flow characteristics of the vent outlet closing device, the measurement of the pressure drop versus the rate of volume flow using water and with any intended flame or insect screens in place and also tightness tests during immersion/ emerging in water, whereby the automatic closing device is to be subjected to a series of tightness tests involving not less than two (2) immersion cycles under each of the following conditions:

- The automatic closing device is to be submerged slightly below the water surface at a velocity of approximately 4 m/min (13.12 ft/min) and then returned to the original position immediately. The quantity of leakage is to be recorded.
- The automatic closing device is to be submerged to a point slightly below the surface of the water. The submerging velocity is to be approximately 8 m/min and the air pipe vent head is to remain submerged for not less than 5 minutes. The quantity of leakage is to be recorded.
- Each of the above tightness tests are to be carried out in the normal position as well as at an inclination of 40 degrees under the strictest conditions for the device. In cases where such strictest conditions are not clear, tests shall be carried out at an inclination of 40 degrees with the device opening facing in three different directions: upward, downward, sideways (left or right). See 4-6-4/Figures 3 to 6.

The maximum allowable leakage per cycle is not to exceed 2 ml/mm (1.312×10^{-2} gal/inch) of nominal diameter of inlet pipe during any individual test.

- ii) *Discharge/Reverse Flow Test.* The air pipe head shall allow the passage of air to prevent excessive vacuum developing in the tank. A reverse flow test shall be performed. A vacuum pump or another suitable device shall be connected to the opening of the air pipe leading to the tank. The flow velocity shall be applied gradually at a constant rate until the float gets sucked and blocks the flow. The velocity at the point of blocking shall be recorded. 80% of the value recorded will be stated in the certificate. Each type and size of vent outlet automatic closing device is to be surveyed and type tested at the manufacturer's works or other acceptable location.

- iii) *Testing of Nonmetallic Floats.* Impact and compression loading tests are to be carried out on the floats before and after pre-conditioning as follows:

Test temperature °C (°F):	-25°C (-13°F)	20°C (68°F)	85°C (185°F)
Test conditions			
Dry	Yes	Yes	Yes
After immersing in water	Yes	Yes	Yes
After immersing in fuel oil	NA	Yes	NA

Immersing in water and fuel oil is to be for at least 48 hours.

Impact Test. The test may be conducted on a pendulum type testing machine. The floats are to be subjected to 5 impacts of 2.5 N-m (1.844 lbf-ft) each and are not to suffer permanent deformation, cracking or surface deterioration at this impact loading.

Subsequently, the floats are to be subjected to 5 impacts of 25 N-m (18.44 lbf-ft) each. At this impact energy level some localized surface damage at the impact point may occur. No permanent deformation or cracking of the floats is to appear.

Compression Loading Test. Compression tests are to be conducted with the floats mounted on a supporting ring of a diameter and bearing area corresponding to those of the float seating with which it is intended that the float shall be used. For a ball type float, loads are to be applied through a concave cap of the same internal radius as the test float and bearing on an area of the same diameter as the seating. For a disc type float, loads are to be applied through a disc of equal diameter as the float.

A load of 3430 N (350 kgf, 770 lbf) is to be applied over one minute and maintained for 60 minutes. The deflection is to be measured at intervals of 10 minutes after attachment of the full load.

The record of deflection against time is to show no continuing increase in deflection and, after release of the load, there is to be no permanent deflection.

- iv) *Testing of Metallic Floats.* The above described impact tests are to be carried out at room temperature and in the dry condition.

FIGURE 3
Example of Normal Position

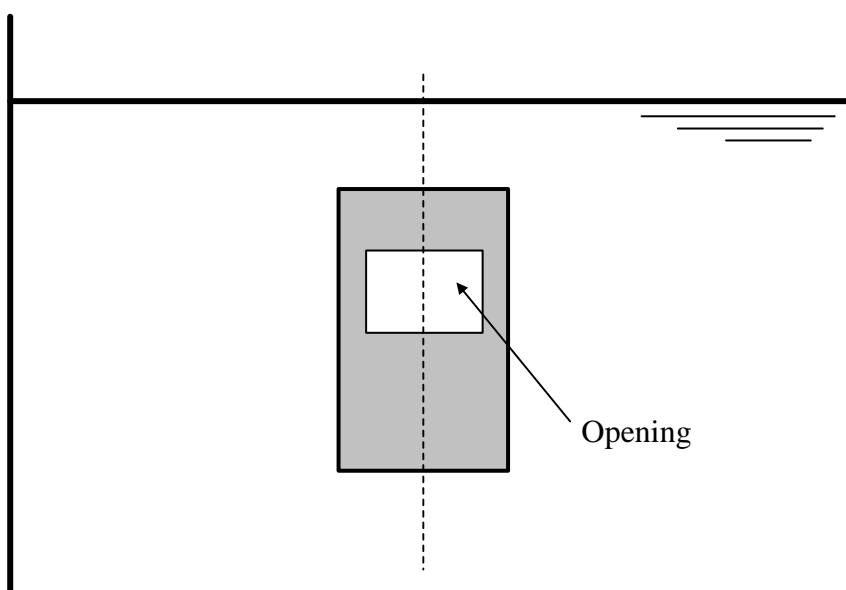

FIGURE 4
Example of Inclination 40 Degrees Opening Facing Upward

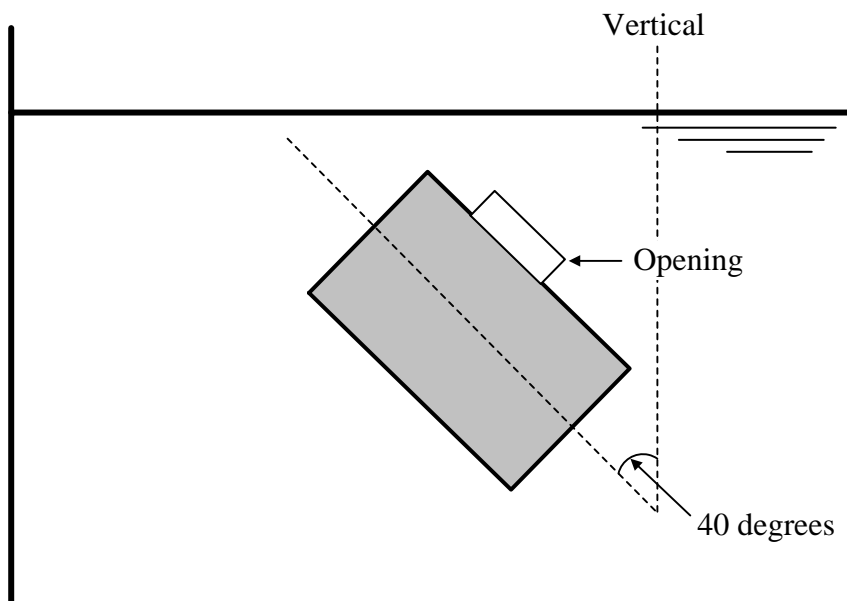

FIGURE 5
Example of Inclination 40 Degrees Opening Facing Downward

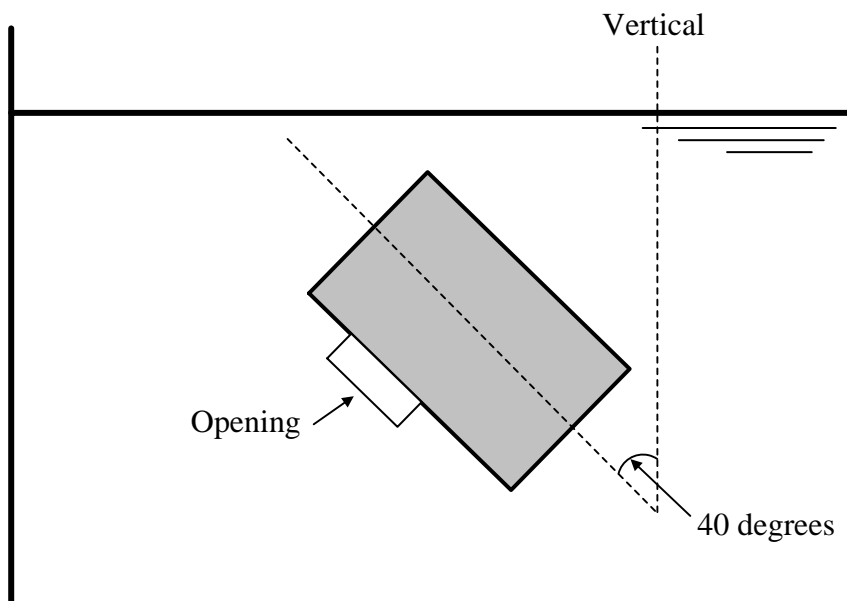
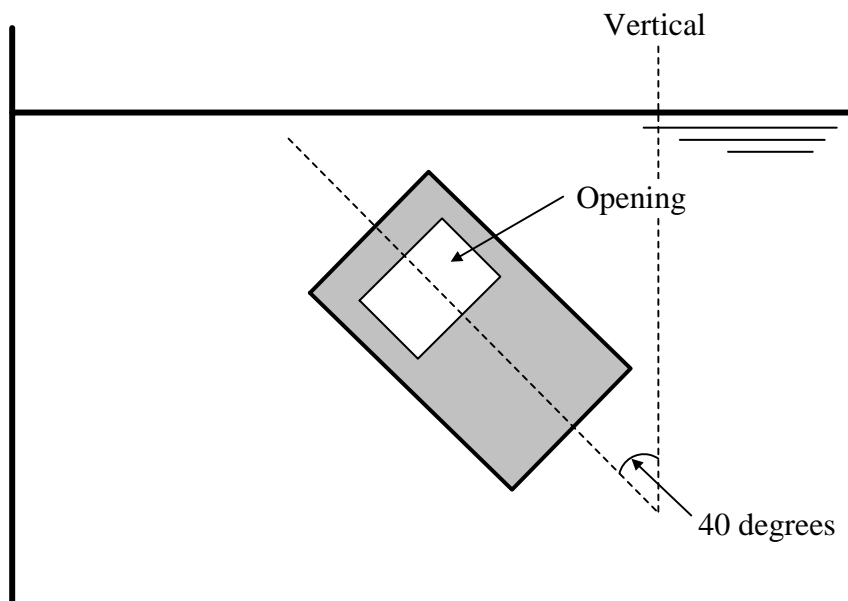

FIGURE 6
Example of Inclination 40 Degrees Opening Facing Sideways



9.5 Tank Overflows

9.5.1 General Requirements

Generally, all tanks capable of being filled by a pumping system, as indicated in 4-6-4/9.1.2, are to be provided with a means of overflow. This may be achieved by overflowing through dedicated overflow pipes or through the tank vents, provided the size of the vents meet 4-6-4/9.3.3(b). Overflows are to discharge outboard, i.e., on the weather deck or overboard, or into designated overflow tanks. Overflow lines are to be self-draining.

9.5.2 Overflow Pipe Size

In general, the aggregate area of the overflow pipes is not to be less than 125% of the effective area of the filling line. Where high capacity or high head pumps are used, calculations demonstrating the adequacy of the overflow as well as the vent to prevent over- or underpressurization of the ballast tanks are to be submitted. See also 4-6-4/9.3.3(b). Where overflows complying with this requirement are fitted, tank vents need only meet the minimum size complying with 4-6-4/9.3.3(a). Where, however, tank vents complying with 4-6-4/9.3.3(b) are fitted, separate overflows will not be required.

9.5.3 Overflows Discharging Overboard

In general, overflow pipes discharging through the vessel's sides are to be led above the freeboard deck and are to be fitted with a non-return valve (not to be of cast iron, see 4-6-2/9.13.2) at the shell.

Where the overflow discharging overboard cannot be led above the freeboard deck, the opening at the shell is to be protected against sea water ingress in accordance with the same provisions as that for overboard gravity drain from watertight spaces described in 4-6-4/3.3. In this connection, the vertical distance of the 'inboard end' from the summer load water line may be taken as the height from the summer load water line to the level that the sea water has to rise to find its way inboard through the overboard pipe.

Where, in accordance with the provisions of 4-6-4/3.3, a non-return valve with a positive means of closing is required, means is to be provided to prevent unauthorized operation of this valve. This may be a notice posted at the valve operator warning that it may be shut by authorized personnel only.

9.5.4 Overflow Common Header

Where overflows from tanks in more than one watertight subdivision are connected to a common header below the freeboard or bulkhead deck, the arrangement is to be such as to prevent fore-and-aft flooding from one watertight subdivision to another in the event of damage.

9.5.5 Overflows from Combustible and Flammable Liquid Tanks

Tanks containing combustible and flammable liquids are not to be fitted with overflows discharging overboard. Overflow pipes from these tanks are to be led to an overflow tank or to a storage tank with sufficient excess capacity (normally 10 minutes at transfer pump capacity) to accommodate the overflow. The overflow tank is to be provided with a high level alarm, see 4-6-4/13.5.4. Where a sight flow glass is also provided in the overflow pipe, then such sight glasses are to be fitted only in vertical sections of overflow pipes and be in readily visible positions.

Where a common vent/overflow header is provided for fuel oil storage and day tanks, the vent/overflow header need not be fitted with a separate vent pipe leading directly to atmosphere. The individual tanks and the common vent/overflow header may be vented through the overflow tank vent line to atmosphere, provided the common vent/overflow header arrangement has the following features/conditions:

- i)* Each vent/overflow line from the tank to the common header, the vent/overflow common headers and the vent line from the overflow tank to the atmosphere are to be sized in order to provide a venting area of at least 125% of the effective fill line area of the shore filling line or onboard transfer line, whichever is greater. Fuel oil tank scantlings are to consider the height of the overflow tank vent.
- ii)* Each storage tank is to be fitted with a high level alarm and a high-high level alarm. Both level alarms are to provide visual and audible indication of the alarm condition at a manned station (such as wheel house, engine control room or an equivalent station) from where filling/transfer operation is controlled.
- iii)* The drop lines from the common headers to the overflow tank are to terminate above the maximum liquid level in the overflow tank (i.e., above the alarm point where the liquid reaches a predetermined level in the overflow tank to give the high level warning).
- iv)* The venting arrangement of the overflow tank is to permit the free passage of air from the individual tanks, the vent/overflow headers and the overflow tank vent to atmosphere under all conditions
- v)* The storage tanks are not to be filled by using a cascade filling arrangement (i.e., tanks are not to be filled by overflowing from one to another).
- vi)* The fueling station(s) is to be manned at all times during bunkering and/or fuel oil transfer operations.
- vii)* In lieu of items *i)* through *vi)*; the overflow line common header may be vented to the atmosphere in accordance with 4-6-4/9.3.3, in addition to the overflow tank being fitted with a dedicated vent pipe.

9.5.6 Overflow Pipe Wall Thickness

In general, overflow pipes exposed to the weather are to have wall thicknesses not less than standard thickness, see 4-6-4/9.3.2(a). Overflow pipes not exposed to the weather are to meet the thickness requirements of vents in 4-6-4/9.3.2(b). However, that portion of the overflow pipe subject to the provisions of 4-6-4/3.3, as indicated in 4-6-4/9.5.3, are to be in accordance with the pipe wall thicknesses in 4-6-4/3.3.

11 Means of Sounding

11.1 General

11.1.1 Application

These requirements apply to the provision of a means of sounding for liquid and void tanks and for normally dry but not easily accessible compartments. The requirements in this subsection, however, do not apply to sounding arrangements of liquid cargoes, such as crude oil, liquefied gases, chemicals, etc., for which specific requirements of provided in Part 5C and Part 5D.

The means of sounding covered in this subsection include sounding pipes and gauge glasses. For level-indicating devices fitted to tanks containing flammable liquid, such as fuel oil, see 4-6-4/13.5.6(b). Remote tank level indicating systems are to be submitted for consideration in each case.

11.1.2 Basic Requirements

All tanks, cofferdams, void spaces and all normally dry compartments, such as cargo holds, which are not easily accessible, and which have the possibility of water accumulation (e.g., adjacent to sea, pipe passing through), are to be provided with a means of the sounding level of liquid present. In general, this means is to be a sounding pipe. A gauge glass, level indicating device, remote-gauging system, etc. may also be accepted as a means of sounding.

11.3 Sounding Pipes

11.3.1 General Installation Requirements

Sounding pipes are to be led as straight as possible from the lowest part of tanks or spaces and are to be terminated in positions which are always accessible under all operational conditions of the vessel. Sounding pipes installed in compartments, such as the cargo holds, where they may be exposed to mechanical damage, are to be adequately protected.

11.3.2 Sounding Pipe Size

The internal diameter of the sounding pipe is not to be less than 32 mm (1.26 in.).

11.3.3 Sounding Pipe Wall Thickness

Steel sounding pipes are to have wall thickness not less than that given in the appropriate column (A, C or D) of 4-6-2/Table 4 and in accordance with their locations of installation as follows:

- i) Within the tank to which the sounding pipe serves: column A.
- ii) Exposed to weather and outside the tank to which the sounding pipe serves: column C.
- iii) Passing through fuel oil or ballast tanks and outside the tank to which the sounding pipe serves: column D.
- iv) Passing through the bilge well and outside the tank to which the sounding pipe serves: extra heavy thickness (see 4-6-1/3.9).

11.3.4 Materials of Sounding Pipes

The material of sounding pipes for tanks containing flammable liquids is to be steel or equivalent. Plastic pipes may be used in such tanks and all other tanks subject to compliance with the following:

- The plastic pipe is confined to within the tank which the sounding pipe serves.
- The penetration of the tank boundary is of steel.
- The plastic pipes used are in compliance with Section 4-6-3.

11.3.5 Protection of Tank Bottom Plating

Provision is to be made to protect the tank bottom plating from repeated striking by the sounding device. Such provision may be a doubler plate fitted at the tank bottom in way of the sounding pipe, or equivalent.

11.3.6 Deck of Termination and Closing Device

Sounding pipes are to be terminated on decks on which they are always accessible under normal operating conditions so as to enable sounding of the tanks. In general, the exposed end of each sounding pipe is to be provided with a watertight closing device, permanently attached, such as a screw cap attached to the pipe with a chain.

Sounding pipes of double bottom tanks and tanks whose boundaries extend to the shell at or below the deepest load water line are, in addition, to terminate on or above the freeboard deck. This is so that in the event of a shell damage in way of the tank, the opening of the sounding pipe will not cause inadvertent flooding of internal spaces. Termination below the freeboard deck is permitted, however, if the closing device fitted at the open end is a gate valve, or screw cap. For oil tanks, the closing device is to be of the quick acting valve, see also 4-6-4/11.3.7.

11.3.7 Sounding Pipes of Fuel Oil and Lubricating Oil Tanks

Sounding pipes from fuel oil tanks are not to terminate in any spaces where a risk of ignition of spillage exists. In particular, they are not to terminate in passenger or crew spaces, in machinery spaces or in close proximity to internal combustion engines, generators, major electric equipment or surfaces with temperature in excess of 220°C (428°F). Where this is not practicable, the following are to be complied with.

11.3.7(a) Fuel oil tanks. Sounding pipes from fuel oil tanks may terminate in machinery spaces provided that the following are met:

- i) The sounding pipes are to terminate in locations remote from the ignition hazards, or effective precautions, such as shielding, are taken to prevent fuel oil spillage from coming into contact with a source of ignition.
- ii) The termination of sounding pipes is fitted with a quick-acting self-closing valve and with a small diameter self-closing test cock or equivalent located below the self-closing valve for the purpose of ascertaining that fuel oil is not present before the valve is opened. Provisions are to be made to prevent spillage of fuel oil through the test cock from creating an ignition hazard.
- iii) A fuel oil level gauge complying with 4-6-4/13.5.6(b) is fitted. However, short sounding pipes may be used for tanks other than double bottom tanks without the additional closed level gauge, provided an overflow system is fitted. See 4-6-4/13.5.4.

11.3.7(b) Lubricating oil tanks. Sounding pipes from lubricating oil tanks may terminate in machinery spaces provided that the following are met:

- i) The sounding pipes are to terminate in locations remote from the ignition hazards, or effective precautions, such as shielding, are taken to prevent oil spillage from coming into contact with a source of ignition.
- ii) The termination of sounding pipes is fitted with a quick-acting self-closing gate valve. Alternatively, for lubricating oil tanks that cannot be filled by a pump, the sounding pipes may be fitted with an appropriate means of closure, such as a shutoff valve or a screw cap attached by chain to the pipe.

11.5 Gauge Glasses

11.5.1 Flat Glass Type

Where gauge glasses are installed as means of level indication, flat glass type gauge glasses are required for the following tanks:

- Tanks whose boundaries extend to the vessel's shell at or below the deepest load waterline.
- Tanks containing flammable liquid (except as indicated in 4-6-4/11.5.2 for hydraulic oil and for small tanks).

Flat glass type gauge glasses are to be fitted with a self-closing valve at each end and are to be adequately protected from mechanical damage.

11.5.2 Tubular Glass Type

11.5.2(a) General. Tubular glass gauge glasses may be fitted to tanks other than those mentioned in 4-6-4/11.5.1. A self-closing valve is to be fitted at each end of the gauge glass.

11.5.2(b) Hydraulic oil tanks. Tubular glass gauge glasses with a self-closing valve at each end may be fitted to hydraulic oil tanks provided:

- The tanks are located outside machinery spaces of category A,
- The space does not contain ignition sources such as diesel engines, major electrical equipment, hot surfaces having a temperature of 220°C (428°F) or more, and
- The tank boundaries do not extend to the shell at or below the deepest load water line.

11.5.2(c) Small tanks. Small tanks, including those containing hydraulic oil or lubricating oil located in a machinery space of category A, may be fitted with tubular glass gauge glasses without a valve at the upper end, subject to the following:

- The tank capacity does not exceed 100 liters (26.5 gallons).
- A self-closing valve is fitted at the lower end.
- The upper connection is as close to the tank top as possible and is to be above the maximum liquid level in the tank.
- The gauge glass is so located or protected that any leakage therefrom will be contained.

11.5.2(d) Fresh water tanks. Structural tanks whose boundaries do not extend to the vessel's shell, and independent tanks for fresh water may all be fitted with tubular glass gauge glasses with a valve at each end or a valve at the bottom end of the glass.

11.7 Level Indicating Device

Where a level-indicating device is provided for determining the level in a tank containing flammable liquid, the failure of the device is not to result in the release of the contents of the tank through the device. Level switches, which penetrate below the tank top, may be used, provided they are contained in a steel enclosure or other enclosures not being capable of being destroyed by fire.

Where the device is located, such that it is subjected to a head of oil, a valve is to be fitted to allow for its removal, see 4-6-2/9.11.3. If an overflow is not fitted, means are also to be provided to prevent overfilling of the tank in the event of malfunction of the indicating device/system.

11.9 Remote Level Indicating Systems

Where fitted, plans showing the arrangements and details of the system, along with particulars of the sensing and transmitting devices, are to be submitted for review in each case.

13 Fuel Oil Storage and Transfer Systems

13.1 General

13.1.1 Application

The provisions of 4-6-4/13 apply to fuel oil storage, transfer and processing systems, in general. They are to be applied, as appropriate, together with fuel oil system requirements specific to each type of propulsion or auxiliary plant provided in 4-6-5/3 (for internal combustion engines) and 4-6-6/7 (for boilers). For location of fuel tanks in cargo area on oil and chemical tankers, see 5C-1-1/5.35 and 5C-9-3/9, respectively.

13.1.2 Fuel Oil Flash Point

The provisions of this subsection apply to fuel oils having a flash point (closed cup test) above 60°C (140°F).

Fuel oil with a flash point of 60°C or below, but not less than 43°C (110°F), may only be used for vessels classed for services in specified geographical areas. The climatic conditions of such areas are to preclude the ambient temperature of spaces where such fuel oil is stored from rising to within 10°C (18°F) below its flash point.

Notwithstanding this restriction, prime movers of emergency generators may use fuel oil with a flash point of not less than 43°C (110°F), subject to the following:

The use of fuel oil having a flashpoint of less than 60°C but not less than 43°C may be permitted (e.g. for feeding the emergency fire pump's engines and the auxiliary machines which are not located in the machinery spaces of category A) subject to the following:

- i) Fuel oil tanks except those arranged in double bottom compartments are located outside of machinery spaces of category A;
- ii) Provisions for measurement of oil temperature are provided on the suction pipe of oil fuel pump;
- iii) Stop valves and/or cocks are provided on the inlet side and outlet side of the fuel oil strainers;
- iv) Pipe joints of welded construction or of circular cone type or spherical type union joint are applied as much as possible.

Fuel oil vent pipes are to extend at least 2.4 m (8 ft) above the weather deck or other effective arrangements which have been approved are to be provided.

13.1.3 Basic Requirement

The intent of the requirements of 4-6-4/13 for fuel oil systems is to minimize the possibility of fire due to fuel oil primarily by identifying and separating likely fuel leakages from ignition sources, collection and drainage of fuel leakages and proper design of fuel containment systems.

13.3 Installation Requirements

13.3.1 Access, Ventilation and Maintenance

All spaces where fuel oil installations, settling tanks or service tanks are located are to be easily accessible. Such spaces are to be sufficiently ventilated to prevent accumulation of oil vapor. As far as practicable, materials of either combustible or oil-absorbing properties are not to be used in such spaces.

13.3.2 Hot Surfaces

To prevent the ignition of fuel oil, all hot surfaces, e.g., steam and exhaust piping, turbochargers, exhaust gas boilers, etc. likely to reach a temperature above 220°C (428°F) during service are to be insulated with non-combustible, and preferably non-oil-absorbent, materials. Such insulation materials, if not impervious to oil, are to be encased in oil-tight steel sheathing or equivalent. The insulation assembly is to be well installed and supported having regard to its possible deterioration due to vibration.

13.3.3 Arrangement of Fuel Oil Equipment and Piping

As far as practicable, fuel oil tanks, pipes, filters, heaters, etc. are to be located far from sources of ignition, such as hot surfaces and electrical equipment. In particular, they are not to be located immediately above nor near such ignition sources. The number of pipe joints is to be kept to a minimum. Spray shields are to be fitted around flanged joints, flanged bonnets and any other flanged or threaded connections in fuel oil piping systems under pressure exceeding 1.8 bar (1.84 kgf/cm², 26 psi) which are located above or near units of high temperature, including boilers, steam pipes, exhaust manifolds, silencers or other equipment required to be insulated in accordance with 4-6-4/13.3.2, and also to avoid oil spray or oil leakage into machinery air intakes or other sources of ignition.

13.3.4 Leakage Containment and Drainage System

13.3.4(a) Leakage containment. Fuel oil system components, such as pumps, strainers, purifiers, etc., and fuel oil heaters, which require occasional dismantling for examination, and where leakage may normally be expected, are to have drip pans fitted underneath to contain the leakage.

In way of valves fitted near the bottom of fuel oil tanks located above the double bottom and in way of other tank fittings, where leakage may be expected, drip pans are also to be provided.

Free standing fuel oil tanks are to be provided with oil tight spill trays, as required in 4-6-4/13.5.2.

13.3.4(b) Drainage. Drip pans, spill trays and other leakage containment facilities are to be provided with a means of drainage. Where they are led to a drain tank, protection against back flows and venting through the drain lines is to be provided as follows:

- i) The drain tank is not to form part of the fuel oil overflow system.
- ii) The drain tank is to be fitted with a high level alarm for propulsion machinery spaces intended for centralized operation (**ACC** notation) or unattended operation (**ACCU** or **ABCU** notation). See 4-9-5/15.1.2, 4-9-6/17 and 4-9-7/1.5.
- iii) Where drain lines entering the tank are not fitted with non-return valves, they are to be led to the bottom of the tank to minimize venting of the tank through the drain lines. This is not applicable to fuel oil drain tanks with a volume less than 2 m³ (70.6 ft³) and which cannot be filled up by a pump. Regarding termination of air vents, see 4-6-4/9.3.4(a).
- iv) Where the drain tank is a double bottom tank, all drain lines entering the tank are to be fitted with non-return valves at the tank so as to protect the engine room from flooding in case of bottom damage to the tank.
- v) The drain tank is to be fitted with a pumping arrangement to enable transfer of its content to the shore facility or to other waste oil tanks

13.3.5 Valve Operation

Valves related to fuel oil systems are to be installed in readily operable and accessible positions.

13.5 Fuel Oil Tanks

13.5.1 Arrangements of Structural Tanks

13.5.1(a) Machinery space of category A. As far as practicable, fuel oil tanks are to be part of the vessel's structure and located away from the machinery spaces of category A. However, where it is found necessary to locate the fuel oil tanks adjacent to or inside the machinery spaces of category A, the arrangements are to reduce the area of the tank boundary common with the machinery space of category A to a minimum, and to comply with the following:

- i) Fuel tanks having boundaries common with machinery spaces of category A are not to contain fuel oils having flash point of 60°C (140°F) or less.
- ii) At least one of their vertical sides is to be contiguous to the machinery space boundary. The arrangements in 4-6-4/Figure 7 are acceptable for structural tanks provided the requirements of 4-6-4/17.3 are complied with. (The side shell is not being included as a contiguous boundary of the category A machinery space.)
- iii) The bottom of the fuel oil tank is not to be so exposed that it will be in direct contact with flame should there be a fire in a Category A machinery space. The fuel tank is to extend to the double bottom. Alternatively, the bottom of the fuel oil tank is to be fitted with a cofferdam. The cofferdam is to be fitted with suitable drainage arrangements to prevent accumulation of oil in the event of oil leakage from the tank.
- iv) Fuel oil tanks are to be located such that no spillage or leakage therefrom can constitute a hazard by falling on heated surfaces or electrical equipment. If this is not practicable, the latter are to be protected from such spillage or leakage by shields, coamings or trays as appropriate.

FIGURE 7
Acceptable Fuel Oil Tanks Arrangements Inside Category A Machinery Spaces

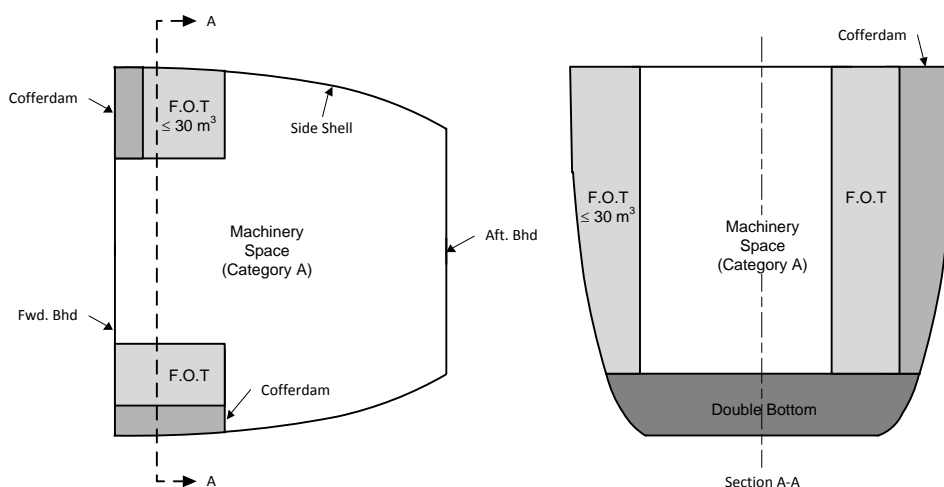

13.5.1(b) *Drainage of water.* Means are to be provided for draining water from the bottom of the settling tanks. Where there are no settling tanks installed similar arrangements for draining the water is to be fitted to the fuel oil storage or the daily service tank.

Where the drainage of water from these tanks is through open drains, valves or cocks of a self-closing type, arrangements such as gutterways or other similar means are to be provided for collecting the drains. Means are to be provided to collect the oily discharge.

13.5.1(c) *Location.* Tanks forward of the collision bulkhead are not to be arranged for the carriage of fuel oil. See also 3-2-10/1.3.

13.5.1(d) *Service tanks.* A service tank is a fuel tank which contains only fuel of a quality ready for use, that is, fuel of a grade and quality that meets the specification required by the equipment manufacturer. A service tank is to be declared as such and is not to be used for any other purpose.

For vessels of 500 gross tonnage and above, at least two fuel oil service tanks for each type of fuel used onboard necessary for propulsion and vital systems, or equivalent arrangements, are to be provided. Each service tank is to have a capacity of at least eight (8) hours at maximum continuous rating of the propulsion plant and normal operating load at sea of the generator plant.

For propulsion machinery spaces intended for centralized or unattended operation (**ACC** or **ACCU** or **ABCU** notation), low level conditions of fuel oil settling and service tanks are to be alarmed at the centralized control station. Where tanks are automatically filled, high level alarms are also to be provided. For **ACCU** notation, these tanks are to be sized for at least 24-hour operation without refilling, except that for automatically filled tanks, 8-hour operation will suffice, see also 4-9-5/15.1.1, 4-9-6/3.3, and 4-9-6/Tables 1, 3B, 4.

Use of a settling tank with or without purifiers or use of purifiers alone is not acceptable as an equivalent arrangement to providing a service tank. 4-6-4/Table 2 shows examples of acceptable arrangements.

TABLE 2
Alternative Arrangements for Fuel Oil Service Tanks

	<i>Consumption</i>	<i>Number of Service Tanks Required</i>	<i>Acceptable Alternative Service Tanks</i>	<i>Comments</i>
Mono-fuel vessels (HFO)	HFO: PE+GE+AB	2×8 hr HFO	1×8 hr HFO (PE+GE+AB), and 1×8 hr MDO (PE+GE+AB)	Duplication of tank for MDO for initial cold start of engines/boilers is not required. However, if AB is fitted with pilot burner, another 8 hr MDO tank for this purpose is required. AB need not be accounted if exhaust gas boiler is normally used for heating HFO.
Dual-fuel vessels (HFO + MDO) ⁽¹⁾	HFO: PE+AB	2×8 hr HFO	1×8 hr HFO (PE +AB) and the greater of:	
	MDO: GE	2×8 hr MDO	2×4 hr MDO (PE + GE+AB); or 2×8 hr MDO (GE +AB)	

Legend: PE = propulsion engine(s) GE = generator engine(s) HFO = heavy fuel oil
 AB = auxiliary boiler(s) MDO = marine diesel oil

Note:

- 1 This arrangement applies, provided the propulsion and essential systems support rapid fuel changeover and are capable of operating in all normal operating conditions at sea with both types of fuels (MDO and HFO).

13.5.2 Arrangements of Free Standing Tanks

The use of free standing fuel oil tanks in the machinery spaces of category A is to be avoided as far as possible, see the general intent in 4-6-4/13.5.1(a). Where this is unavoidable, free standing fuel oil tanks in machinery spaces of category A are to be kept to a minimum and their installation is to be as follows:

- The fuel oil tanks are to be placed in an oil tight spill tray of ample size (e.g., large enough to cover leakage points such as manhole, drain valves, gauge glass, etc.) with a drainage facility to a suitable drain tank.
- The fuel oil tanks are not to be situated where spillage or leakage therefrom can constitute a hazard by falling on heated surfaces. In particular they are not to be located over boilers.

13.5.3 Valves on Fuel Oil Tanks

13.5.3(a) Required Valves. Every fuel oil pipe emanating from any fuel oil tank, which, if damaged, would allow fuel oil to escape from the tank, is to be provided with a positive closing valve. The valve is to be secured directly on the tank. A short length of pipe, with wall thickness in accordance to Column D of 4-6-2/Table 4, connecting the valve to the tank is also acceptable. The valve is not to be of cast iron, although the use of nodular cast iron is permissible, see 4-6-2/3.1.4. The positive closing valve is to be provided with means of closure both locally and from a readily accessible and safe position outside of the space. In the event that the capacity of the tank is less than 500 liters (132 US gallons), this remote means of closure may be omitted.

If the required valve is situated in a shaft tunnel or pipe tunnel or similar spaces, the arrangement for remote closing may be effected by means of an additional valve on the pipe or pipes outside the tunnel or similar spaces. If such an additional valve is fitted in a machinery space, it is to be provided with a means of closure both locally and from a readily accessible position outside of this space.

When considering two adjacent fuel oil tanks, the fuel oil suction pipe from the tank on the far side may pass through the adjacent tank, and the required positive closing valve may be located at the boundary of the adjacent tank. In such instances, the thickness of the fuel oil suction pipe passing through the adjacent fuel oil tank is to be in accordance with Column C in 4-6-2/Table 4 and of all welded construction.

13.5.3(b) Remote Means of Closure. The remote closure of the valves may be by reach rods or by electric, hydraulic or pneumatic means. The source of power to operate these valves is to be from outside of the space in which these valves are situated. For a pneumatically operated system, the air supply may be from a source located within the same space as the valves provided that an air receiver complying with the following is located outside the space:

- Sufficient capacity to close all connected valves twice.
- Fitted with low air pressure alarm.
- Fitted with a non-return valve adjacent to the air receiver in the air supply line.

This remote means of closure is to override all other means of valve control. The use of an electric, hydraulic or pneumatic system to keep the valve in the open position is not acceptable.

Materials readily rendered ineffective by heat are not to be used in the construction of the valves or the closure mechanism unless protected adequately to ensure effective closure facility in the event of fire. Electric cables, where used, are to be fire-resistant, meeting the requirements of IEC Publication 60331. See 4-8-3/9.7.

The controls for the remote means of closure of the valves of the emergency generator fuel tank and the emergency fire pump fuel tank, as applicable, are to be grouped separately from those for other fuel oil tanks.

13.5.4 Filling and Overflow

13.5.4(a) Bunker Lines. The bunkering of fuel oils is to be effected by means of permanently installed lines either from the open deck or from bunkering stations located below deck which are to be isolated from other spaces without danger. Bunker stations are to be so arranged that the bunkering can be performed from both sides of the vessel. Alternatively, one bunkering line capable of being extended to both sides of the vessel may be accepted provided the bunkering stations are so arranged that visual communication with the bunker vessel can be assured. The bunkering lines are to be fitted with blind/blank flanges on deck or suitable alternative means of isolating the lines.

13.5.4(b) Fuel Oil Tank Filling and Overflow. In general, filling lines are to enter at or near the top of the tank; but if this is impracticable, they are to be fitted with a non-return valve at the tank. Alternatively, the filling line is to be fitted with a remotely operable valve as required by 4-6-4/13.5.3(a). Overflows from fuel oil tanks are to be led to an overflow tank with sufficient volume to accommodate the overflows (normally 10-minutes at transfer pump capacity). A high level alarm is to be provided for the overflow tank. Overflow lines are to be self-draining.

13.5.5 Vents

Vents are to be fitted to fuel oil tanks and are to meet the requirements of 4-6-4/9.

13.5.6 Level Measurement

13.5.6(a) Sounding pipes. Sounding pipes are to meet the general requirements of 4-6-4/11.

13.5.6(b) Level gauges. Level gauges may be fitted in lieu of sounding pipes, provided that the failure of, or the damage to, the level gauge will not result in the release of fuel oil. Where the gauge is located such that it is subjected to a head of oil, a valve is to be fitted to allow for its removal, see 4-6-2/9.11.3. The level gauge is to be capable of withstanding the hydrostatic pressure at the location of installation, including that due to overfilling. For passenger vessels, no level gauge is to be installed below the top of the tank.

13.5.6(c) Gauge glasses. Gauge glasses complying with the intent of 4-6-4/13.5.6(b) may be fitted in lieu of sounding pipes, provided they are of flat glass type with a self-closing valve at each end and are adequately protected from mechanical damage. See also 4-6-4/11.5.1.

13.5.6(d) Level switches. Where fitted, they are to be encased in steel, or equivalent, such that no release of fuel oil is possible in the event of their damage due to fire. Where the device is located, such that it is subjected to a head of oil, a valve is to be fitted to allow for its removal, see 4-6-2/9.11.3.

13.5.6(e) *High level alarm.* To prevent spillage, an alarm is to be fitted to warn of the level reaching a predetermined high level. For tanks fitted with overflow arrangements, the high level alarm may be omitted, provided a flow sight glass is fitted in the overflow pipes. Such flow sight glass is to be fitted only on the vertical section of overflow pipe and in readily visible position.

13.5.6(f) *Additional level alarms.* For propulsion machinery spaces intended for centralized or unattended operation (**ACC**, **ACCU** or **ABCU** notation), low level conditions of fuel oil settling and service tanks are to be alarmed at the centralized control station. Where tanks are automatically filled, high level alarms are also to be provided. However, where a service tank is fitted with overflow arrangement in accordance with 4-6-4/9.5, the high level alarm is to be fitted in the tank to which the service tank overflows. For **ACCU** and **ABCU** notation, these tanks are to be sized for at least 24-hour operation without refilling, except that for automatically filled tanks, 8-hour operation will suffice.

13.5.7 Heating Arrangements in Tanks

13.5.7(a) *Flash point.* Fuel oil in storage tanks is not to be heated within 10°C (18°F) below its flash point. Where fuel oil in service tanks, settling tanks and any other tanks in the supply system is heated, the arrangements are to comply with the following:

- i) The length of the vent pipes from the tanks and/or cooling device is to be sufficient for cooling the vapors to below 60°C, or the outlet of the vent pipes is located at least 3 m (10 ft) away from a source of ignition.
- ii) There are no openings from the vapor space of the fuel tanks leading into machinery spaces, except for bolted manholes.
- iii) Enclosed spaces, such as workshops, accommodation spaces, etc., are not to be located directly over the fuel tanks, except for vented cofferdams.
- iv) Electrical equipment is not to be fitted in the vapor space of the tanks, unless it is certified to be intrinsically safe.

13.5.7(b) *Fuel oil temperature control.* All heated fuel oil tanks located within machinery spaces are to be fitted with a temperature indicator. Means of temperature control are to be provided to prevent overheating of fuel oil, in accordance with 4-6-4/13.5.7(a).

13.5.7(c) *Temperature of heating media.* Where heating is by means of a fluid heating medium (steam, thermal oil, etc.), a high temperature alarm is to be fitted to warn of any high medium temperature. This alarm may be omitted if the maximum temperature of the heating medium can, in no case, exceed 220°C (428°F).

13.5.7(d) *Steam heating.* To guard against possible contamination of boiler feed water, where fuel oil tanks are heated by steam heating coils, steam condensate returns are to be led to an observation tank, or other approved means, to enable detection of oil leaking into the steam system.

13.5.7(e) *Electric heating.* Where electric heating is installed, the heating elements are to be arranged to be submerged at all times during operation, and are to be fitted with an automatic means of preventing the surface temperature of the heating element from exceeding 220°C (428°F). This automatic feature is to be independent of the fuel oil temperature control and is to be provided with manual reset.

13.5.7(f) **ACC**, **ACCU** and **ABCU** notation. For vessels whose propulsion machinery spaces are intended for centralized or unattended operation (**ACC**, **ACCU** or **ABCU** notation), see 4-9-5/15.1.3.

13.7 Fuel Oil System Components

13.7.1 Pipes and Fittings

13.7.1(a) *General.* Fuel oil pipes, valves and fittings are to be of steel or other approved materials.

13.7.1(b) *Pipes.* Pipes are to meet the general requirements of certification in 4-6-1/7.1; materials in 4-6-2/3; and design in 4-6-2/5.1, subject to the following:

- i) Pipes passing through fuel oil tanks are to be of steel except that other materials may be considered where it is demonstrated that the material is suitable for the intended service.
- ii) Limited use of plastic pipes will be permitted, subject to compliance with the requirements of Section 4-6-3.
- iii) For pipes, the design pressure is to be taken in accordance with 4-6-4/Table 3.

TABLE 3
Design Pressure for Fuel Oil Pipes

Maximum Allowable Working Pressure (P)*	Maximum Working Temperature (T)	
	$T \leq 60^{\circ}\text{C} (140^{\circ}\text{F})$	$T > 60^{\circ}\text{C} (140^{\circ}\text{F})$
$P \leq 7 \text{ bar} (7.15 \text{ kgf/cm}^2, 101.5 \text{ psi})$	3 bar (3.1 kgf/cm ² , 43 psi) or P*, whichever is greater	3 bar (3.1 kgf/cm ² , 43 psi) or P*, whichever is greater
$P > 7 \text{ bar} (7.15 \text{ kgf/cm}^2, 101.5 \text{ psi})$	P*	14 bar (14.3 kgf/cm ² , 203 psi) or P*, whichever is greater

* P = maximum allowable working pressure of the system, as defined in 4-6-1/3.19, in bar (kgf/cm², psi)

13.7.1(c) *Pipe fittings and joints.* Pipe fittings and joints are to meet the general requirements of certification in 4-6-1/7.1; materials in 4-6-2/3; and design in 4-6-2/5.5 and 4-6-2/5.15 subject to limitations in 4-6-4/Table 4. Fittings and joints in piping systems are also to be compatible with the pipes to which they are attached in respect of their strength (see 4-6-4/13.7.1(a)iii for design pressure) and are to be suitable for effective operation at the maximum allowable working pressure they will experience in service. For flanges, their pressure-temperature rating is subject to the limitations in 4-6-2/5.5.4.

13.7.1(d) *Hoses.* Hoses, where installed, are to comply with 4-6-2/5.7. Hose clamps are not permitted.

TABLE 4
Pipe Joint Limitations for Fuel Oil Piping

<i>Types of joint</i>	<i>Class I</i>	<i>Class II</i>	<i>Class III</i>
Butt welded joint	No limitation	No limitation	No limitation
Socket welded joint ⁽¹⁾	Max. 80 mm (3 in.)	Max. 80 mm (3 in.)	No limitation
Slip-on welded sleeve joint ⁽²⁾	Max. 80 mm (3 in.)	Max. 80 mm (3 in.)	No limitation
Flanged joint	Types A, B & G only. For type G, see 4-6-2/Table 7	Types A, B, C & G only. For type G, see 4-6-2/Table 7	Types A, B, C & G only. For type G, see 4-6-2/Table 7
Taper-thread joint	≤ 80 mm (3 in.) Permissible pressure/size: see 4-6-2/5.5.5(a)	≤ 80 mm (3 in.) Permissible pressure/size: see 4-6-2/5.5.5(a)	No limitation.
Compression couplings ⁽³⁾	≤ 60 mm (2.4 in.) OD.	≤ 60 mm (2.4 in.) OD.	No size limitation.
Molded non-metallic expansion joint	Not permitted	Not permitted	Not permitted
Molded expansion joint of composite construction	Subject to compliance with 4-6-2/5.8.1(b)	Subject to compliance with 4-6-2/5.8.1(b)	Subject to compliance with 4-6-2/5.8.1(b)
Metallic bellow type expansion joint	No limitation	No limitation	No limitation
Slip-on joints	See Note 3	See Note 3	See Note 3
Hoses	Subject to fire resistance test: 4-6-2/5.7.3(c).	Subject to fire resistance test: 4-6-2/5.7.3(c).	Subject to fire resistance test: 4-6-2/5.7.3(c).

Notes:

- 1 See 4-6-2/5.5.2 for further operational limitations.
- 2 See 4-6-2/5.5.3 for further operational limitations.
- 3 See 4-6-2/5.9 for further limitations.

Pipe sizes are nominal bore, except where indicated otherwise.

13.7.2 Valves

Valves are to meet the general requirements of certification in 4-6-1/7.1; materials in 4-6-2/3; and design in 4-6-2/5.11 and 4-6-2/5.13. Cast iron valves are not to be used as shutoff valves for fuel oil tanks, as indicated in 4-6-4/13.5.3(a).

Valves in piping systems are also to be compatible with the pipes to which they are attached in respect to their strength, (see 4-6-4/13.7.1(a)iii) for design pressure) and are to be suitable for effective operation at the maximum allowable working pressure they will experience in service. Their pressure rating is subject to the limitations in 4-6-2/5.11.2.

13.7.3 Pumps

Fuel oil pumps are to be fitted with stop valves at the suction and discharge sides. A relief valve is to be fitted on the discharge side, unless the pump is of the centrifugal type having a shutoff head no greater than the design pressure of the piping system. Where fitted, the relief valve is to discharge to the suction side of the pump or into the tank.

Fuel oil pumps requiring certification are specified in 4-6-1/7.3. See also 4-6-5/3 and 4-6-6/7.

13.7.4 Heaters

13.7.4(a) Heater housing. All fuel oil heaters having any of the following design parameters are to be certified by ABS (for pressure vessels, see Section 4-4-1):

- Design pressure > 6.9 bar (7 kgf/cm², 100 psi) on either side;
- Design pressure > 1 bar (1 kgf/cm², 15 psi), internal volume > 0.14 m³ (5 ft³), and design temperature > 66°C (150°F) on the oil side or > 149°C (300°F) on the heating medium side;
- All fired heaters with design pressure > 1 bar (1 kgf/cm², 15 psi).

Electric oil heaters not required to be certified by the above are to have their housing design submitted for review.

13.7.4(b) Fuel oil temperature control. All heaters are to be fitted with a fuel oil temperature indicator and a means of temperature control.

13.7.4(c) Heating media and electric heating. The provisions of 4-6-4/13.5.7(c), (d) and (e) are also applicable to fuel oil heaters.

13.7.4(d) Relief valves. Relief valves are to be fitted on the fuel oil side of the heaters. The discharge from the relief valve is to be arranged to discharge back to the storage tank or other suitable tank of adequate capacity.

13.7.4(e) ACC, ACCU or ABCU notation. For vessels whose propulsion machinery spaces are intended for centralized or unattended operation (**ACC**, **ACCU** or **ABCU** notation), see 4-9-5/15.1.3.

13.7.5 Filters and Strainers

Filters and strainers are to be designed to withstand the maximum working pressure of the system in which they are installed.

Where filters and strainers are fitted in parallel to enable cleaning without disrupting the oil supply, means are to be provided to minimize the possibility of a filter or strainer being opened inadvertently.

Where they are required to be opened for cleaning during operation, they are to be fitted with means of depressurizing before being opened and venting before being put into operation. For this purpose, valves and cocks for drainage and venting are to be provided. Drain pipes and vent pipes are to be led to a safe location. For leakage containment and drainage, see 4-6-4/13.3.4.

13.7.6 Sight Flow Glasses

A sight flow glass may be fitted only in the vertical sections of fuel oil overflow pipes, and provided that it is in a readily visible position.

13.9 Fuel Oil Transfer, Filling and Purification Systems

13.9.1 Fuel Oil Transfer Pumps

There are to be at least two fuel oil transfer pumps. At least one of the pumps is to be independent of the main engine. Fuel oil transfer pumps are to be fitted with remote means of controls situated outside the space in which they are located so that they may be stopped in the event of fire in that space.

For filling and overflow, see 4-6-4/13.5.4. For automatic filling in propulsion machinery spaces intended for centralized or unattended operation (**ACC**, **ACCU** or **ABCU** notation), see 4-6-4/13.5.6(f).

13.9.2 Segregation of Purifiers for Heated Fuel Oil

Fuel oil purifiers for heated oil are to be placed in a separate room or rooms, enclosed by steel bulkheads extending from deck to deck and provided with self-closing doors. In addition, the room is to be provided with the following:

- i) Independent mechanical ventilation or ventilation arrangement that can be isolated from the machinery space ventilation, of the suction type.
- ii) Fire detection system.
- iii) Fixed fire-extinguishing system capable of activation from outside the room. The extinguishing system is to be dedicated to the room but may be a part of the fixed fire extinguishing system for the machinery space.

However, for the protection of purifiers on cargo vessels of 2000 gross tonnage and above located within a machinery space of category A above 500 m³ (17,657 ft³) in volume, the above referenced fixed dedicated system is to be a fixed water-based or equivalent, local application fire-extinguishing system complying with the provisions of 4-7-2/1.11.2. The system is to be capable of activation from outside the purifier room. In addition, protection is to be provided by the fixed fire-extinguishing system covering the Category A machinery space in which the purifier room is located, see 4-7-2/1.1.1.

- iv) Means of closing ventilation openings and stopping the ventilation fans, purifiers, purifier-feed pumps, etc. from a position close to where the fire extinguishing system is activated.

If it is impracticable to locate the fuel oil purifiers in a separate room, special consideration will be given with regard to location, containment of possible leakage, shielding and ventilation. In such cases, a local fixed water-based fire-extinguishing system complying with the provisions of 4-7-2/1.11.2 is to be provided. Where, due to the limited size of the category A machinery space (less than 500 m³ (17,657 ft³) in volume), a local fixed water-based fire-extinguishing system is not required to be provided, then an alternative type of local dedicated fixed fire-extinguishing system is to be provided for the protection of the purifiers. In either case, the local fire extinguishing system is to activate automatically or manually from the centralized control station or other suitable location. If automatic release is provided, additional manual release is also to be arranged.

13.11 Waste Oil Systems for Incinerators

The requirements for fuel oil storage, transfer and heating, as provided in 4-6-4/13, are applicable to waste oil service tanks and associated piping systems for incinerators.

15 Lubricating Oil Storage and Transfer Systems

15.1 General and Installation Requirements

15.1.1 Application

The provisions of 4-6-4/15 apply to storage and transfer and processing of lubricating oil. They are to be applied, as appropriate, together with requirements for lubricating oil systems specific to each type of propulsion or auxiliary machinery specified in 4-6-5/5 (for internal combustion engines) and 4-6-6/9 (for steam turbines). In addition, the requirements of 4-6-4/13.5.7(b) through (f) and 4-6-4/13.7.4 are applicable.

15.1.2 Basic Requirement

The requirements for the lubricating oil storage and transfer system are intended to minimize the fire risks of lubricating oil.

15.1.3 Dedicated Piping

The lubricating oil piping, including vent and overflow piping, is to be entirely separated from other piping systems.

15.1.4 Hot Surfaces

To prevent the ignition of lubricating oil, all hot surfaces, e.g., steam and exhaust piping, turbochargers, exhaust gas boilers, etc. likely to reach a temperature above 220°C (428°F) during service are to be insulated with non-combustible, and preferably non-oil-absorbent, materials. Such insulation materials, if not impervious to oil, are to be encased in oil-tight steel sheathing or equivalent. The insulation assembly is to be well installed and supported having regard to its possible deterioration due to vibration.

15.1.5 Arrangement of Lubricating Oil Equipment and Piping

As far as practicable, lubricating oil tanks, pipes, filters, heaters, etc. are to be located far from sources of ignition, such as hot surfaces and electrical equipment. In particular, they are not to be located immediately above nor near such ignition sources. The number of pipe joints is to be kept to a minimum. Spray shields are to be fitted around flanged joints, flanged bonnets and any other flanged or threaded connections in lubricating oil piping systems under pressure exceeding 1.8 bar (1.84 kgf/cm², 26 psi) which are located above or near units of high temperature, including boilers, steam pipes, exhaust manifolds, silencers or other equipment required to be insulated in accordance with 4-6-4/15.1.4, and also to avoid oil spray or oil leakage into machinery air intakes or other sources of ignition.

15.1.6 Leakage Containment

Lubricating oil system components, such as pumps, strainers, purifiers, etc., which require occasional dismantling for examination, and where leakage may normally be expected, are to be provided with leakage containment and drainage arrangements, as required in 4-6-4/13.3.4.

15.3 Lubricating Oil Tanks

15.3.1 Location

Tanks forward of the collision bulkhead are not to be arranged for the carriage of lubricating oil. See also 3-2-10/1.3. They are not to be situated where spillage or leakage therefrom can constitute a hazard by falling on heated surfaces or electrical equipment.

15.3.2 Valves on Lubricating Oil Tanks

Normally opened valves on lubricating oil tanks are to comply with the same requirements as those for fuel oil tanks given in 4-6-4/13.5.3. To protect propulsion and essential auxiliary machinery not fitted with automatic shutdown upon loss of lubricating oil, the remote means of closing the lubricating oil tank valve may be omitted if its inadvertent activation from the remote location could result in damage to such machinery.

15.3.3 Vents

Vents are to meet the applicable requirements in 4-6-4/9. Lubricating oil tank vents may terminate within the machinery space provided that the open ends are situated to prevent the possibility of overflowing on electric equipment, engines or heated surfaces.

15.3.4 Level Measurement

15.3.4(a) Sounding pipes. Sounding pipes are to meet the applicable requirements in 4-6-4/11.

15.3.4(b) Level gauges. Level gauges may be fitted in lieu of sounding pipes, provided that the failure of, or the damage to, the level gauge will not result in the release of lubricating oil. Where the device is located such that it is subjected to a head of oil, a valve is to be fitted to allow for its removal, see 4-6-2/9.11.3. The level gauge is to be capable of withstanding the hydrostatic pressure at the location of installation, including that due to overfilling. For passenger vessels, no level gauge is to be installed below the top of the tank.

15.3.4(c) Gauge glasses. Gauge glasses complying with the intent of 4-6-4/15.3.4(b) may be fitted in lieu of sounding pipes, provided they are of flat glass type with a self-closing valve at each end and are adequately protected from mechanical damage.

15.3.4(d) Level switches. Where fitted, they are to be encased in steel, or equivalent, such that no release of lubricating oil is possible in the event of their damage due to fire. Where the device is located such that it is subjected to a head of oil, a valve is to be fitted to allow for its removal, see 4-6-2/9.11.3.

15.3.4(e) Level alarms. For propulsion machinery spaces intended for centralized or unattended operation (**ACC**, **ACCU** or **ABCU** notation), lubricating oil tank low-level alarms are to be provided for:

- Crosshead (slow-speed) propulsion diesel engines (see 4-9-6/Table 1A);
- Gas turbines and reduction gears (see 4-9-6/Table 3);
- Steam turbines and gears (see 4-9-6/Table 2).

15.5 Lubricating Oil System Components

15.5.1 Pipes, Fittings and Valves

Pipes, fittings and valves are to comply with the same requirements as those for fuel oil systems in 4-6-4/13.7.1 and 4-6-4/13.7.2, except requirement 4-6-4/13.7.1(a)iii).

15.5.2 Pumps

Lubricating oil pumps requiring certification are specified in 4-6-1/7.3. See also 4-6-5/5 and 4-6-6/9.

15.5.3 Filters and Strainers

Filters and strainers are to comply with the same requirements as for those for fuel oil systems in 4-6-4/13.7.5.

15.5.4 Coolers

Lubricating oil coolers having either of the following design parameters are to be certified by ABS:

- Design pressure > 6.9 bar (7 kgf/cm², 100 psi) on either side;
- Design pressure > 1 bar (1 kgf/cm², 15 psi), internal volume > 0.14 m³ (5 ft³), and design temperature > 90°C (200°F) on the lubricating oil side.

15.5.5 Sight-flow Glasses

A sight flow glass may be fitted only in the vertical sections of lubricating oil overflow pipes, provided that it is in a readily visible position.

15.5.6 Hose Reels

Where hose reels are used for filling the engine or reduction gear sumps with oil, a self-closing valve is to be provided at the end of the filling hose to prevent spillage. Suitable arrangements are to be provided to properly drain and store the hose and reel when not in use. Hoses are to be approved for oil service and in accordance with the requirements for burst pressure, fire resistance, reinforcement and end fittings in 4-6-2/5.7.

17 Additional Measures for Oil Pollution Prevention

17.1 General

17.1.1 Application

The provisions of 4-6-4/17 provide the arrangement of fuel oil tanks for compliance with MARPOL 73/78, as amended. They are to be applied in addition to the requirements of 4-6-4/13 and are applicable to all types of vessels classed with ABS.

17.1.2 Submission of Plans

Plans showing compliance with the applicable requirements in 4-6-4/17.3 are to be submitted for review.

17.3 Tank Protection Requirements

17.3.1 General

The requirements in this section apply to vessels having an aggregate fuel oil capacity of 600 m³ (21,190 ft³) and above. However, the requirements need not be applied to individual fuel oil tanks with a capacity not greater than 30 m³ (1060 ft³), provided that the aggregate capacity of such excluded tanks is not greater than 600 m³ (21,190 ft³). Further, individual fuel oil tanks are not to have capacity greater than 2,500 m³ (88,290 ft³).

Fuel oil tanks of any volume are not to be used for ballast water.

Fuel oil tank means a tank in which fuel oil is carried, but excludes those tanks which would not contain fuel oil in normal operation, such as overflow tanks. Fuel oil capacity means the volume of a tank in cubic meters (cubic feet) at 98% tank filling.

Fuel oil means any oil used as fuel in connection with the propulsion and auxiliary machinery of the ship in which such oil is carried.

17.3.2 Protective Location of Tanks

The protective locations for the tanks specified in 4-6-4/17.3.1 above are to be as follows:

17.3.2(a) Deterministic Approach. All applicable tanks are to be located away from the vessel's bottom or side shell plating for a distance as specified in *i)*, *ii)* or *iii)*. Small suction wells may extend below fuel oil tanks bottoms, if they are as small as possible and the distance between the vessel's bottom plate and the suction well bottom is not reduced by more than half of the distance required by *i)*.

- i)* For vessels having an aggregate oil fuel capacity of 600 m³ (21,190 ft³) and above, all tanks are to be arranged above vessel's molded line of bottom shell plating at least of the distance *h* as specified below:

$$h = B/20 \text{ m or}$$

$$h = 2.0 \text{ m (6.6 ft), whichever is smaller}$$

where *B* is the breadth of the vessel, as defined in 3-1-1/5, in m (ft).

h is in no case to be less than 0.76 m (2.5 ft).

- ii)* For vessels having an aggregate oil fuel capacity greater than or equal to 600 m³ (21190 ft³) but less than 5000 m³ (176570 ft³), tanks are to be arranged inboard of the molded line of side plating not less than the distance *w* as specified below:

$$w = 0.4 + 2.4C/20000 \text{ m}$$

$$w = 1.31 + 7.87C/706290 \text{ ft}$$

where

C = vessel's total volume of oil fuel in m³ (ft³) at 98% tank filling;

w = at least 1.0 m (3.3 ft)

for individual tanks smaller than 500 m³ (17,657 ft³) *w* is to be at least 0.76 m (2.5 ft)

- iii)* For vessels having an aggregate oil fuel capacity of 5000 m³ (176570 ft³) and above, tanks are to be arranged inboard of the molded line of side plating not less than the distance *w* as specified below:

$$w = 0.5 + C/20000 \text{ m}$$

$$w = 1.64 + C/706290 \text{ ft or}$$

$$w = 2.0 \text{ m}$$

$$w = 6.6 \text{ ft, whichever is smaller}$$

where *C* is the vessel's total volume of oil fuel in m³ (ft³) at 98% tank filling.

The minimum value of *w* = 1.0 m (3.3 ft).

17.3.2(b) Probabilistic Approach. As an alternative to the deterministic approach of 4-6-4/17.3.2(a), arrangements complying with the accidental oil fuel outflow performance standard of Regulation 12A, Annex I, MARPOL 73/78, as amended, would be acceptable.

17.3.2(c) Main Engine Lubricating Oil Drain Tanks. Tanks for lubricating oil under main engines are to have the vertical distance from the bottom of such a well to a plane coinciding with the keel line not less than 500 mm (19.7 in.). This is not applicable for vessels under 500 gross tonnage.

17.5 Class Notation – POT

In addition to the requirements for fuel oil tank protection as specified in 4-6-4/17.3.1 utilizing the deterministic approach of 4-6-4/17.3.2(a), where lubricating oil tanks with a capacity greater than 30 m³ (1060 ft³) (other than tanks for lubricating oil under main engines) are also arranged in the same manner as required by the deterministic approach [4-6-4/17.3.2(a)] for fuel oil tanks, vessels are to be eligible for the optional Class notation, **POT** – Protection of Fuel and Lubricating Oil Tanks.

Further, in application of equation in 4-6-4/17.3.2(a)ii) or iii), total volume of lubricating oil tanks need not be accounted for *C* (vessel's total volume of oil fuel in m³ (ft³) at 98% tank filling).

PART

4

CHAPTER 6 Piping Systems

SECTION 5 Piping Systems for Internal Combustion Engines

1 Applications

The provisions of this Section are applicable to systems essential for operation of internal combustion engines (diesel engines and gas turbines) and associated reduction gears intended for propulsion and electric power generation. These systems include fuel oil, lubricating oil, cooling, starting air, exhaust gas and crankcase ventilation. Reference should be made to Section 4-2-1 and Section 4-2-3 for engine appurtenances of diesel engines and gas turbines, respectively.

These provisions contain requirements for system design, system components and specific installation details. Requirements for plans to be submitted, pipe materials, pipe and pipe fitting designs, fabrication, testing, general installation details and component certification are given in Section 4-6-1 and Section 4-6-2. For plastic piping, see Section 4-6-3.

3 Fuel Oil Systems

3.1 General

3.1.1 Application

The provisions of 4-6-5/3 apply to systems supplying fuel oil to internal combustion engines intended for propulsion and power generation. Requirements for shipboard fuel oil storage, transfer, heating and purification, as provided in 4-6-4/13, are to be complied with. System component requirements in 4-6-4/13.7 are applicable here also.

3.1.2 Fuel Oil Flash Point

The provisions of 4-6-5/3 are intended for internal combustion engines burning fuel oils having a flash point (closed cup test) above 60°C (140°F). Engines burning fuel oil of a lesser flash point are subject to special consideration. In general, fuel oil with a flash point of 60°C (140°F) or below, but not less than 43°C (110°F), may only be used for vessels classed for services in specific geographical areas. The climatic conditions in these areas are to preclude the ambient temperature of spaces where such fuel oil is stored from rising to within 10°C (18°F) below its flash point.

Engines driving emergency generators and emergency fire pumps may use fuel oil with a flash point of 60°C (140°F) or below, but not less than 43°C (110°F).

3.1.3 Basic Requirement

The intent of the provisions of 4-6-5/3 along with those of 4-6-4/13 is:

- To provide for a reliable source of fuel oil supply to the prime movers for propulsion and power generation, primarily by means of certification of critical components and providing redundancy in the system, so that propulsion and maneuvering of the vessel may still be possible in the event of single failure in the system;
- To minimize the possibility of fire due to fuel oil, primarily by identifying and segregating likely fuel leakages from ignition sources, collection and drainage of fuel leakages and proper design of fuel containment systems.

3.3 Fuel Oil Service System for Propulsion Diesel Engines

3.3.1 Service and Booster Pumps

3.3.1(a) Standby pump, single engine installation. An independently driven standby pump is to be provided for each service pump, booster pump and other pumps serving the same purpose.

The capacity of the pumps, with any one pump out of service, is to be sufficient for continuous operation at rated power.

3.3.1(b) Standby pump, multiple engine installation. For vessels fitted with two or more propulsion engines, the provision of a common standby pump (for each service pump, booster pump, etc.) capable of serving all engines will suffice rather than providing individual standby pumps for each engine.

3.3.1(c) Attached pumps. For multiple engine installations, engines having service, booster or similar pumps attached to and driven by the engine may, in lieu of the standby pump, be provided with a complete pump carried on board as a spare. The spare pump, upon being installed, is to allow the operation of the engine at rated power.

The spare pump need not be carried, provided that, in the event of the loss of one engine, at least forty percent of the total rated propulsion power remains.

3.3.1(d) Emergency shutdown. Independently driven fuel oil service pumps, booster pumps and other pumps serving the same purpose are to be fitted with remote means of controls situated outside the space in which they are located so that they may be stopped in the event of fire arising in that space.

3.3.1(e) Certification of pumps. Fuel oil transfer pumps, and fuel oil service and booster pumps associated with propulsion gas turbine and propulsion diesel engines with bores greater than 300 mm (11.8 in.) are to be certified in accordance with 4-6-1/7.3.

3.3.2 Fuel-injector Cooling Pumps

Where pumps are provided for fuel injector cooling, a standby pump is to be fitted as per 4-6-5/3.3.1

3.3.3 Heaters

When fuel oil heaters are required for propulsion engine operation, at least two heaters of approximately equal size are to be installed. The combined capacity of the heaters is not to be less than that required by the engine(s) at rated power. See 4-6-4/13.7.4 for heater design requirements.

3.3.4 Filters or Strainers

Filters or strainers are to be provided in the fuel oil injection-pump suction lines and are to be arranged such that they can be cleaned without interrupting the fuel supply. This may be achieved by installing two such filters or strainers in parallel or installing the duplex type with a changeover facility that will enable cleaning without interrupting the fuel supply. An auto-backwash filter satisfying the same intent may also be accepted. See 4-6-4/13.7.5 for depressurization and venting requirements.

Filters and strainers are to be arranged and located so that, in the event of leakage, oil will not spray onto surfaces with temperature in excess of 220°C (428°F).

3.3.5 Purifiers

Where heavy fuel oil is used, the number and capacity of purifiers are to be such that with any unit not in operation, the remaining unit(s) is to have a capacity not less than that required by the engines at rated power.

3.3.6 Piping Between Booster Pump and Injection Pumps

In addition to complying with 4-6-4/13.7.1, pipes from booster pump to injection pump are to be seamless steel pipe of at least standard wall thickness. Pipe fittings and joints are to be in accordance with 4-6-4/Table 3, subject to further limitations as follows:

- Connections to valves and equipment may be of taper-thread joints up to 50 mm (2 in.) nominal diameter; and
- Pipe joints using taper-thread fittings and screw unions are not to be in sizes of 25 mm (1 in.) nominal diameter and over.

Spray shields are to be fitted around flanged joints, flanged bonnets and any other flanged or threaded connections in fuel oil piping systems under pressure exceeding 0.18 N/mm² (1.84 kgf/cm², 26 psi) which are located above or near units of high temperature, including boilers, steam pipes, exhaust manifolds, silencers or other equipment required to be insulated by 4-6-4/13.3.2, and to avoid, as far as practicable, oil spray or oil leakage into machinery air intakes or other sources of ignition. The number of joints in such piping systems is to be kept to a minimum.

3.3.7 Piping Between Injection Pump and Injectors

3.3.7(a) *Injection piping.* All external high-pressure fuel delivery lines between the high-pressure fuel pumps and fuel injectors are to be protected with a jacketed piping system capable of containing fuel from a high-pressure line failure. A jacketed pipe incorporates an outer pipe into which the high-pressure fuel pipe is placed, forming a permanent assembly. Metallic hose of approved design may be accepted as the outer pipe, where outer piping flexibility is required for the manufacturing process of the permanent assembly. The jacketed piping system is to include means for collection of leakages, and arrangements are to be provided for an alarm to be given of a fuel line failure.

3.3.7(b) *Fuel oil returns piping.* When the peak-to-peak pressure pulsation in the fuel oil return piping from the injectors exceeds 20 bar (20.5 kgf/cm², 285 lb/in²), jacketing of the return pipes is also required.

3.3.7(c) *High pressure common rail system.* Where a high pressure common rail system is fitted to an engine, the high pressure common rail is to be in accordance with Section 4-4-1 for pressure vessels, or a recognized standard as listed in 4-4-1/1.5. Alternatively, the design may be verified by certified burst tests. Components are to be made of steel or cast steel. Components made of steel, other than cast steel, are to withstand not less than 4 times the maximum allowable working pressure. The cast steel common rails are to withstand not less than 5 times the maximum allowable working pressure. The use of non-ferrous materials, cast iron and nodular iron is prohibited. Materials are to comply with Chapter 3 of the *ABS Rules for Materials and Welding (Part 2)*.

The high pressure common rail system is required to be properly enclosed and provided with arrangement for leak collection and alarm in case of a failure of the high pressure common rail system, see 4-6-5/3.3.7(a).

3.3.8 Isolating Valves in Fuel Supply and Spill Piping

In multi-engine installations on vessels 500 gross tons and above, which are supplied from the same fuel source, a means of isolating the fuel supply and spill (return) piping to individual engines is to be provided. The means of isolation is not to affect the operation of the other engines and is to be operable from a position not rendered inaccessible by a fire on any of the engines.

3.5 Fuel Oil Service System for Auxiliary Diesel Engines

3.5.1 Service Pumps

Where generator engines are provided with a common fuel oil service pump or similar, a standby pump capable of serving all engines is to be installed. Engines having individual service pumps, or having service pumps attached to and driven by the engines need not be provided with a standby service pump.

3.5.2 Fuel Injector Cooling Pumps

Where pumps are provided for fuel injector cooling, the provision for a standby pump is to be in accordance with 4-6-5/3.5.1.

3.5.3 Heaters

When fuel oil heaters are required for generator engine operation, at least two heaters of approximately equal size are to be installed. The capacity of the heaters, with one heater out of operation, is not to be less than that required by the engine(s) at a power output for the normal sea load specified in 4-8-2/3.1.1. For generator engines arranged for alternately burning heavy fuel oil and diesel oil, consideration may be given to providing one heater only.

3.5.4 Filters or Strainers

Where common filters or strainers are provided to serve the fuel oil injection-pump suction lines of all of the generator engines, they are to be arranged such that they can be cleaned without interrupting the power supply specified in 4-8-2/3.1.1. In the case where each of the generator engines is fitted with its own strainer or filter, this arrangement alone will suffice. See also 4-8-2/5.17.1(c).

3.5.5 Piping

Applicable requirements of 4-6-5/3.3.6 and 4-6-5/3.3.7 are to be complied with.

3.5.6 Isolating Valves in Fuel Supply and Spill Piping

For multi-engine installations, the requirements of 4-6-5/3.3.8 are to be complied with.

3.7 Fuel Oil Service System for Gas Turbines

3.7.1 General

The fuel oil service system is to be in accordance with 4-6-5/3.3 for propulsion gas turbines and 4-6-5/3.5 for generator gas turbines, as applicable, and the provisions in 4-6-5/3.7.

3.7.2 Shielding of Fuel Oil Service Piping

Piping between the service pump and the combustors is to be effectively jacketed or shielded as in 4-6-5/3.3.6 or 4-6-5/3.3.7, respectively.

3.7.3 Fuel Oil Shutoff

3.7.3(a) *Automatic shutoff.* Each gas turbine is to be fitted with a quick closing device which will automatically shut off the fuel supply upon sensing malfunction in its operation, see 4-2-3/7.7.2 for a complete list of automatic shutdowns.

3.7.3(b) *Hand trip gear.* Hand trip gear for shutting off the fuel supply in an emergency is also to be fitted, see 4-2-3/7.9.

3.9 System Monitoring and Shutdown

4-6-5/Table 1 summarizes the basic alarms and shutdown required for fuel oil systems, as required by 4-6-4/13 and 4-6-5/3.

Propulsion machinery spaces intended for centralized or unattended operation are to be fitted with additional alarms and automatic safety system functions. See, e.g., 4-9-6/Table 1A, 4-9-6/Table 1B, and 4-9-6/Table 3 for propulsion engines and 4-9-6/Table 6 for auxiliary engines.

**TABLE 1
 Fuel Oil System Alarms and Shutdown**

<i>Equipment</i>	<i>Requirement</i>	<i>Reference</i>
Overflow tank	High-level alarm	4-6-4/13.5.4
Fuel oil tank	High-level alarm, unless overflow is fitted	4-6-4/13.5.6(e)
Fuel oil heaters	High-temperature alarm unless heating medium precludes overheating.	4-6-4/13.5.7(b) and 4-6-4/13.7.4(b)
Fuel oil pumps	Remote manual shutdown	4-6-5/3.3.1(d)
Fuel oil supply to gas turbines	Automatic shutdown and alarms for specified conditions	4-6-5/3.7.3(a)
Fuel delivery pipes	Leak alarm	4-6-5/3.3.7(a), 4-6-5/3.5.5 and 4-6-5/3.7.2

3.11 Testing and Trials

Hydrostatic tests are to be in accordance with 4-6-2/7.3.1 and 4-6-2/7.3.3. The system is to be tried under working condition in the presence of a Surveyor.

3.13 Use of Natural Gas (NG) in Dual Fuel Diesel Engines and Gas Turbines

Where a dual fuel system is to be installed, compliance with the *ABS Guide for Propulsion and Auxiliary Systems for Gas Fueled Ships* or the *ABS Guide for Propulsion Systems for LNG Carriers* as applicable, is required.

See Sections 5C-13-1 through 5C-13-19 for requirements based on the International Code of Safety for Ships Using Gases or other Low-Flashpoint Fuels (IGF Code).

5 Lubricating Oil Systems

5.1 General

5.1.1 Application

The provisions of 4-6-5/5 apply to lubricating oil systems of internal combustion engines and their associated reduction gears intended for propulsion and power generation. Requirements for lubricating oil storage and transfer systems as provided in 4-6-4/15 are to be complied with. System component requirements in 4-6-4/15.5 are applicable here also.

5.1.2 Basic Requirement

The intent of the provisions of 4-6-5/5 and 4-6-4/15 is to:

- i) Provide for continuity of supply of lubricating oil or provide reasonable redundancy in lubricating oil supply to the propulsion and auxiliary machinery;
- ii) Provide warning of failure of lubricating oil system and shutdown to prevent rapid deterioration of propulsion and auxiliary machinery;
- iii) Minimize the fire risks of lubricating oil.

5.1.3 Vessel Inclination (1 July 2018)

The lubricating oil systems and the associated equipment are to have the capability of satisfactory operation when the vessel is inclined at the angles indicated in 4-1-1/7.9. **Consideration is to be given to all acceptable fill levels in the lube oil sumps and tanks for compliance with this requirement.**

5.1.4 Dedicated Piping

The lubricating oil piping, including vents and overflows, is to be entirely separated from other piping systems.

5.3 Lubricating Oil Systems for Propulsion Engines

5.3.1 Lubricating Oil Pumps

5.3.1(a) Standby pump. Each pressurized lubricating oil system essential for operation of the propulsion engine, turbine or gear is to be provided with at least two lubricating oil pumps, at least one of which is to be independently driven. The capacity of the pumps, with any one pump out of service, is to be sufficient for continuous operation at rated power. For multiple propulsion unit installations, one or more independently driven standby pumps may be provided such that all units can be operated at rated power in the event of any one lubricating oil pump for normal service being out of service.

5.3.1(b) Attached pump. For multiple engine installations, where the lubricating oil pump is attached to and driven by the engine, the turbine or the gear, and where lubrication before starting is not necessary, the independently driven standby pump required in 4-6-5/5.3.1(a) is not required if a complete duplicate of the attached pump is carried onboard as a spare.

The spare pump need not be carried, provided that, in the event of the loss of one engine, at least forty percent of the total rated propulsion power remains.

5.3.1(c) *Certification of pumps.* Lubricating oil pumps for propulsion gas turbine, propulsion diesel engines with bores greater than 300 mm (11.8 in.) and reduction gears associated with these propulsion engines and turbine are to be certified in accordance with 4-6-1/7.3.

5.3.2 Lubricating Oil Failure Alarms

Audible and visual alarms are to be fitted for each lubricating oil system of engine, turbine or gear to warn of the failure of the lubricating oil system where engines are having a rated power greater than 37 kW (50 hp).

5.3.3 Gas Turbines and Associated Reduction Gears

Propulsion gas turbines are to be fitted with an automatic quick acting device to shut off the fuel supply upon failure of the lubricating oil supply to the gas turbine or the associated gear.

5.3.4 Diesel Engines and Associated Reduction Gears

Where reduction gears are driven by diesel engines, an automatic means is to be fitted to stop the engines in the event of failure of the lubricating oil supply to the reduction gear. See 4-6-5/Table 2.

5.3.5 Lubricating Oil Coolers

For all types of propulsion plants, oil coolers with means for controlling the lubricating oil temperature are to be provided. Lubricating oil coolers are to be provided with means to determine the oil temperature at the outlet. See also 4-6-5/7.7.3 for cooling water requirements.

5.3.6 Filters and Strainers

5.3.6(a) *Safety requirements.* Strainers and filters are also to be arranged and located so that, in the event of leakage, oil will not spray onto surfaces with temperature in excess of 220°C (428°F). See 4-6-4/13.7.5 for depressurization and venting requirements.

5.3.6(b) *Gas turbines.* A magnetic strainer and a fine mesh filter are to be fitted in the lubricating oil piping to the turbines. Each filter and strainer is to be of the duplex type or otherwise arranged so that it may be cleaned without interrupting the flow of oil.

5.3.6(c) *Diesel engines.* An oil filter of the duplex type is to be provided or otherwise arranged so that it may be cleaned without interrupting the flow of oil. In the case of main propulsion engines which are equipped with full-flow-type filters, the arrangement is to be such that the filters may be cleaned without interrupting the oil supply.

5.3.6(d) *Reduction gears.* A magnetic strainer and a fine mesh filter are to be fitted. Each filter and strainer is to be of the duplex type or otherwise arranged so that they may be cleaned without interrupting the flow of oil.

5.3.7 Purifiers

For main propulsion gas turbines, a purifier of the mechanical type is to be provided for separation of dirt and water from the lubricating oil in systems containing more than 4.0 m³ (4000 liters, 1057 gallons) of lubricating oil.

5.3.8 Drain Pipes

Lubricating oil drain pipes from the engine sumps to the drain tank are to be submerged at their outlet ends.

5.5 Lubricating Oil Systems for Auxiliary Engines

Lubricating oil systems for auxiliary engines driving generators are to meet applicable requirements of 4-6-5/5.3, except as provided below.

5.5.1 Lubricating Oil Pumps

A standby lubricating oil pump is not required for generator diesel engines and gas turbines. For generators driven by the propulsion system, the lubrication of the drive system, if independent of that of the propulsion system, is to be fitted with a standby means of lubrication. This requirement need not apply to drive systems that can be disengaged from the propulsion system.

5.5.2 Strainers and Filters

In multiple-generator installations, each diesel engine or gas turbine may be fitted with a simplex strainer and/or filter provided the arrangements are such that the cleaning can be readily performed by changeover to a standby unit without the loss of propulsion capability. See also 4-8-2/5.17.1(c).

5.7 System Monitoring and Safety Shutdown

4-6-5/Table 2 summarizes the basic alarms of the lubricating oil system and the safety shutdowns as required by 4-6-5/5.

TABLE 2
Lubrication Oil System Basic Alarms and Safety Shutdown

<i>Equipment</i>	<i>Requirement</i>	<i>Reference</i>
Lub. oil system for engines, turbines and gears – propulsion and auxiliary	Failure alarm and shutdown	4-6-5/5.1.2
Propulsion gas turbines and gears, auxiliary gas turbines	Shutdown in case of – turbine of gear lub. oil system failure	4-6-5/5.3.3
Reduction gear	Engines shutdown in case of gear lub. oil system failure	4-6-5/5.3.4 4-8-5/5.17.12

Propulsion machinery spaces intended for centralized or unattended operation are to be fitted with additional alarms and automatic safety system functions. See e.g., 4-9-6/Table 1A, 4-9-6/Table 1B, and 4-9-6/Table 3 for propulsion engines and 4-9-6/Table 6 for generator engines.

5.9 Testing and Trials

Hydrostatic tests are to be in accordance with 4-6-2/7.3.1 and 4-6-2/7.3.3. The system is to be tried under working condition, including simulated functioning of alarms and automatic shutdowns, in the presence of a Surveyor.

7 Cooling System

7.1 General

7.1.1 Application

The provisions of 4-6-5/7 apply to cooling systems of diesel engines and gas turbines and their associated reduction gears, as applicable, intended for propulsion and electric power generation.

7.1.2 Basic Requirements

The requirements for cooling systems are intended to provide for continuity of supply of cooling medium through providing redundancy in the system to the propulsion and auxiliary machinery.

7.3 Cooling System Components

7.3.1 Pumps

Cooling water pumps of propulsion gas turbine and associated reduction gear and cooling water pumps of propulsion diesel engines with bores greater than 300 mm and associated reduction gears are to be certified in accordance with 4-6-1/7.3. Pumps supplying cooling media other than water are to be subjected to the same requirements.

7.3.2 Coolers

7.3.2(a) *General.* Water and air coolers having either of the following design parameters are to be certified by ABS:

- Design pressure > 6.9 bar (7 kgf/cm², 100 lb/in²) on either side
- Design pressure > 1 bar (1 kgf/cm², 15 lb/in²), internal volume > 0.14 m³ (5 ft³), and design temperature > 149°C (300°F) on either side.

7.3.2(b) *Charge air coolers.* Charge air coolers are not subject to 4-6-5/7.3.2(a). They are to be hydrostatically tested on the water side to 4 bar (4.1 kgf/cm², 57 psi), but not less than 1.5 times the design pressure on the water side, either in the manufacturer's plant or in the presence of the Surveyor, after installation onboard the vessel. See also 4-2-1/13.3 for acceptance of manufacturer's certificate.

7.3.3 Pipe Fittings and Joints

Pipe fittings and joints are to meet the requirements for certification in 4-6-1/7.1; materials in 4-6-2/3; and design in 4-6-2/5.5 and 4-6-2/5.15 subject to limitations in 4-6-5/Table 3. Molded non-metallic expansion joints, where used, are to be of an approved type; see 4-6-2/5.8.1.

TABLE 3
Pipe Joint Limitations for Cooling Water Systems

<i>Pipe joints</i>	<i>Class I</i>	<i>Class II</i>	<i>Class III</i>
Butt welded joint	No limitation	No limitation	No limitation
Socket welded joint ⁽¹⁾	Max. 80 mm (3 in.)	Max. 80 mm (3 in.)	No limitation
Slip-on welded sleeve joint ⁽²⁾	Max. 80 mm (3 in.)	Max. 80 mm (3 in.)	No limitation
Flanged joint	Types A, B & G For type G, see 4-6-2/Table 7	Types A, B, C, D & G For type G, see 4-6-2/Table 7	Types A, B, C, D & G For type G, see 4-6-2/Table 7
Taper-thread joint	≤ 80 mm (3 in.) Permissible pressure/size, see 4-6-2/5.5.5(a).	≤ 80 mm (3 in.) Permissible pressure/size, see 4-6-2/5.5.5(a).	No limitation
Compression couplings	≤ 60 mm (2.4 in.) OD	≤ 60 mm (2.4 in.) OD	No limitation
Slip-on joints	See Note 3	See Note 3	See Note 3

Notes:

- 1 See 4-6-2/5.5.2 for further operational limitations.
- 2 See 4-6-2/5.5.3 for further operational limitations.
- 3 See 4-6-2/5.9 for further limitations.

Pipe sizes indicated are nominal diameter, except where specified otherwise.

7.5 Sea Chests

At least two sea chests, located below the lightest waterline, as far apart as practicable and preferably on opposite sides of the vessel, are to be provided. Each of the sea chests is to be capable of supporting the cooling of propulsion and auxiliary machinery and other services drawing sea water from the same sea chest.

For shell valve and sea chest requirements, see 4-6-2/9.13.2 and 4-6-2/9.13.5.

7.7 Cooling Systems for Propulsion and Auxiliary Engines

7.7.1 Cooling Water Pumps

7.7.1(a) *Standby pump.* There are to be at least two means to supply cooling water or other medium to propulsion and auxiliary engines, air compressors, coolers, reduction gears, etc. The capacity of each means is to be sufficient for continuous operation of the propulsion unit and its essential auxiliary services at rated power. One of these means is to be independently driven and may consist of a connection from a suitable pump of adequate size normally used for other purposes, such as a general service pump, or in the case of fresh water cooling, one of the vessel's fresh water pumps.

7.7.1(b) *Attached pumps.* For multiple engine installations, where the cooling pump is attached to and driven by the engine, and the connection to an independently driven pump is impracticable, the standby pump will not be required if a complete duplicate of the attached pump is carried onboard as a spare.

The spare pump need not be carried, provided that, in the event of the loss of one engine, at least forty percent of the total rated propulsion power remains.

7.7.1(c) *Multiple auxiliary engines.* Multiple auxiliary engine installations having individual cooling systems need not be provided with standby pumps.

7.7.2 Strainers

Where sea water is used for direct cooling of the engines, suitable strainers are to be fitted between the sea valve and the pump suction. The strainers are to be either of the duplex type or arranged such that they can be cleaned without interrupting the cooling water supply.

This applies also to engines fitted with indirect cooling where direct sea water cooling is used as an emergency means of cooling.

7.7.3 Cooling Medium Circulation

In general means are to be provided to indicate proper circulation of cooling medium. This may be accomplished by means of pressure or flow and temperature indicators. For diesel engines, the primary cooling medium is to be provided with a pressure indicator at the inlet and with a temperature indicator at the outlet.

All lubricating oil coolers are to be provided with temperature indicators at the cooling medium inlet and at the lubricating oil outlet. Means to determine the cooling medium and lubricating oil pressures are also to be provided.

7.7.4 Overpressure Protection

The cooling water system and all jackets are to be protected against overpressurization, in accordance with 4-6-2/9.9.

7.7.5 System Monitoring and Safety Functions

For propulsion machinery spaces intended for centralized or unattended operations (**ACC**, **ACCU** or **ABCU** notation), alarms for abnormal conditions (pressure and temperature) of the cooling media and automatic safety system functions are to be provided. See e.g., 4-9-6/Table 1A, 4-9-6/Table 1B and 4-9-6/Table 3 for propulsion engines and 4-9-6/Table 6 for generator engines.

7.9 Cooler Installations External to the Hull

7.9.1 General

The inlet and discharge connections of external cooler installations are to be in accordance with 4-6-2/9.13.1 through 4-6-2/9.13.3 and 4-6-2/9.17, except that wafer type valves are acceptable.

7.9.2 Integral Keel Cooler Installations

The positive closing valves required by 4-6-5/7.9.1 above need not be provided if the keel (skin) cooler installation is integral with the hull. To be considered integral with the hull, the installation is to be constructed such that channels are welded to the hull with the hull structure forming part of the channel, the channel material is to be at least the same thickness and quality as that required for the hull and the forward end of the cooler is to be faired to the hull with a slope of not greater than 4 to 1.

If positive closing valves are not required at the shell, all flexible hoses or joints are to be positioned above the deepest load waterline or be provided with an isolation valve.

7.9.3 Non-integral Keel Cooler Installations

Where non-integral keel coolers are used, if the shell penetrations are not fully welded, the penetration is to be encased in a watertight enclosure.

Non-integral keel coolers are to be suitably protected against damage from debris and grounding by recessing the unit into the hull or by the placement of protective guards.

7.11 Testing and Trials

Hydrostatic tests are to be in accordance with 4-6-2/7.3.1 and 4-6-2/7.3.3. The system is to be tried under working condition in the presence of a Surveyor.

9 Starting Air System

9.1 General

9.1.1 Application

The provisions of 4-6-5/9 apply to the starting air systems for propulsion diesel engines and gas turbines.

9.1.2 Basic Requirements

The intent of the requirements in 4-6-5/9 for starting air system is:

- To provide propulsion engines with ready and adequate supply, as well as an adequate reserve, of starting air; and
- To provide for proper design and protection of the compressed air system.

9.1.3 Overpressure Protection

Means are to be provided to prevent overpressure in any part of the compressed air system. This is to include parts of air compressors not normally subjected to air pressure, as indicated in 4-6-5/9.3.2.

9.1.4 Oil and Water Contamination

Provisions are to be made to minimize the entry of oil or water into the compressed air system. Suitable separation and drainage arrangements are to be provided before the air enters the reservoirs.

9.3 Air Compressors

9.3.1 Number and Capacity of Air Compressors

There are to be two or more air compressors, at least one of which is to be driven independently of the propulsion engines, and the total capacity of the air compressors driven independently of the propulsion engines is to be not less than 50% of the total required.

The total capacity of air compressors is to be sufficient to supply, within one hour, the quantity of air needed to satisfy 4-6-5/9.5.1 by charging the reservoirs from atmospheric pressure.

The total capacity, V , required by 4-6-5/9.5.1 is to be approximately equally divided between the number of compressors fitted, n , excluding the emergency air compressor, where fitted. However, one of the air compressors can have a capacity larger than the approximate equal share V/n , provided the capacity of each remaining air compressor is approximately V/n .

9.3.2 Overpressure Protection

Water jackets or casing of air compressors and coolers which may be subjected to dangerous overpressure due to leakage into them from air pressure parts are to be provided with suitable pressure relief arrangements.

9.3.3 Air Compressor Acceptance Test

Air compressors need not be certified by ABS. They may be accepted based on satisfactory performance and verification of capacity stated in 4-6-5/9.3.1 after installation onboard.

9.5 Air Reservoirs

9.5.1 Number and Capacity of Air Reservoirs

Vessels having internal combustion engines arranged for air starting are to be provided with at least two starting air reservoirs of approximately equal size. The total capacity of the starting air reservoirs is to be sufficient to provide, without recharging the reservoirs, at least the number of consecutive starts stated in 4-6-5/9.5.1(a) or 4-6-5/9.5.1(b) plus the requirement in 4-6-5/9.5.1(c). For vessels whose propulsion machinery spaces are intended for centralized or unattended operation (**ACC**, **ACCU** or **ABCU** notation), all starts are to be demonstrated from the engine control room or from the engine control panel on the navigation bridge, whichever location is more demanding on air consumption.

9.5.1(a) *Diesel or turbine propulsion.* The minimum number of consecutive starts (total) required to be provided from the starting air reservoirs is to be based upon the arrangement of the engines and shafting systems, as indicated in 4-6-5/Table 4.

TABLE 4
Required Number of Starts for Propulsion Engines

Engine type	Single propeller vessels		Multiple propeller vessels	
	One engine coupled to shaft directly or through reduction gear	Two or more engines coupled to shaft through clutch and reduction gear	One engine coupled to each shaft directly or through reduction gear	Two or more engines coupled to each shaft through clutch and reduction gear
Reversible	12	16	16	16
Non-reversible	6	8	8	8

9.5.1(b) *Diesel-electric or turbine-electric propulsion.* The minimum number of consecutive starts (total) required to be provided from the starting air reservoirs is to be determined from the following equation:

$$S = 6 + G(G - 1)$$

where

S = total number of consecutive starts

G = number of engines necessary to maintain sufficient electrical load to permit vessel transit at full seagoing power and maneuvering. The value of G need not exceed 3.

9.5.1(c) *Other compressed air systems.* If other compressed air consuming systems, such as control air, are supplied from the starting air reservoirs, the aggregate capacity of the reservoirs is to be sufficient for continued operation of these systems after the air necessary for the required number of starts has been used.

9.5.2 Certification of Starting Air Reservoirs

Starting air reservoirs having a design pressure greater than 6.9 bar (7 kgf/cm², 100 psi) or with a design pressure greater than 1.0 bar (1.0 kgf/cm², 15 psi) and design temperature greater than 149°C (300°F) are to be certified by ABS, see 4-4-1/1.1.

9.5.3 Air Reservoir Fixtures

Air reservoirs are to be installed with drain connections effective under extreme conditions of trim. Where they can be isolated from the system relief valve, they are to be provided with their own relief valves or equivalent devices.

9.5.4 Automatic Charging

Arrangements are to be made to automatically maintain air reservoir pressure at a predetermined level.

9.7 Starting Air Piping

9.7.1 Pipe Fittings and Joints

Pipe fittings and joints are to meet the requirements for certification in 4-6-1/7.1; materials in 4-6-2/3; and design in 4-6-2/5.5 and 4-6-2/5.15, subject to limitations in 4-6-5/Table 5.

TABLE 5
Pipe Joint Limitations for Starting Air Systems

<i>Pipe joints</i>	<i>Class I</i>	<i>Class II</i>	<i>Class III</i>
Butt welded joint	No limitation	No limitation	No limitation
Socket welded joint ⁽¹⁾	Max. 80 mm (3 in.)	Max. 80 mm (3 in.)	No limitation
Slip-on welded sleeve joint ⁽²⁾	Max. 80 mm (3 in.)	Max. 80 mm (3 in.)	No limitation
Flanged joint	Types A, B & G For type G, see 4-6-2/Table 7	Types A, B, C, D & G For type G, see 4-6-2/Table 7	Types A, B, C, D & G For type G, see 4-6-2/Table 7
Taper-thread joint	≤ 80 mm (3 in.) Permissible pressure/size, see 4-6-2/5.5.5(a)	≤ 80 mm (3 in.) Permissible pressure/size, see 4-6-2/5.5.5(a)	No limitation
Compression couplings	≤ 60 mm (2.4 in.) OD	≤ 60 mm (2.4 in.) OD	No limitation

Notes:

- 1 See 4-6-2/5.5.2 for further operational limitations.
- 2 See 4-6-2/5.5.3 for further operational limitations.

Pipe sizes indicated are nominal diameter, except where specified otherwise.

9.7.2 Piping from Compressor to Reservoir

All discharge pipes from starting air compressors are to be led directly to the starting air reservoirs, and all starting air pipes from the air reservoirs to propulsion or auxiliary engines are to be entirely separated from the compressor discharge piping system.

9.7.3 Starting Air Mains

Where engine starting is by direct injection of air into engine cylinders, and in order to protect starting air mains against explosions arising from improper functioning of starting valves, an isolation non-return valve or equivalent is to be installed at the starting air supply connection of each engine. Where engine bore exceeds 230 mm (9¹/₁₆ in.), a bursting disc or flame arrester is to be fitted in way of the starting valve of each cylinder for direct reversing engines having a main starting manifold or at the supply inlet to the starting air manifold for non-reversing engines.

9.9 System Alarms

Where a propulsion engine can be started from a remote propulsion control station, low starting air pressure is to be alarmed at that station. Propulsion machinery spaces intended for centralized or unattended operations (**ACC**, **ACCU** or **ABCU** notation) are also to be provided with alarms for low starting air pressures in the centralized control station.

9.11 Testing and Trials

Hydrostatic tests are to be in accordance with 4-6-2/7.3.1 and 4-6-2/7.3.3. The system is to be tried under working condition in the presence of a Surveyor.

11 Exhaust Gas Piping

11.1 Application (1 July 2018)

These requirements apply to internal combustion engine exhaust gas piping led to the atmosphere through the funnel.

Additional requirements for exhaust emission abatement equipment connected to internal combustion engines are provided in the ABS Guide for Exhaust Emission Abatement.

11.3 Materials

Materials used in the exhaust system are to be resistant to saltwater corrosion, galvanically compatible to each other and resistant to exhaust products. Plate flanges will be considered where the specified material is suitable for exhaust piping pressures and temperatures.

11.5 Insulation

Exhaust pipes are to be water-jacketed or effectively insulated with non-combustible material. In places where oil spray or leakage can occur, the insulation material is not to be of the oil-absorbing type unless encased in metal sheets or equivalent.

11.7 Interconnections

Exhaust pipes of several engines are not to be connected together, but are to be run separately to the atmosphere unless arranged to prevent the return of gases to an idle engine. Boiler uptakes and engine exhaust lines are not to be interconnected except when specially approved as in cases where the boilers are arranged to utilize the waste heat from the engines.

11.9 Installation

Exhaust pipes are to be adequately supported and fitted with means to take account of the expansion and contraction to prevent excessive strain on the pipes. Expansion joints or equivalent may be used.

Precautions are to be taken in the installation of equipment and piping handling fuel oil, lubricating oil and hydraulic oil, such that any oil that may escape under pressure will not come in contact with exhaust gas piping.

Exhaust lines which are led overboard near the waterline are to be protected against the possibility of the water finding its way inboard.

11.11 Diesel Engine Exhaust

11.11.1 Temperature Display

Propulsion diesel engines with bore exceeding 200 mm (7.87 in.) are to be fitted with a means to display the exhaust gas temperature at the outlet of each cylinder.

11.11.2 Alarms

Propulsion machinery spaces intended for centralized or unattended operations (**ACC**, **ACCU** or **ABCU** notation) are to be provided with alarms for high exhaust gas temperature in the centralized control station.

11.13 Gas Turbines Exhaust

The exhaust gas system of gas turbines is to be installed in accordance with the turbine manufacturer's recommendations. In addition, reference is made to 4-2-3/7.13 for the installation of silencers, and to 4-9-6/Table 3 for exhaust gas temperature indication, alarm and automatic shutdown for propulsion machinery spaces intended for centralized or unattended operation.

11.15 Exhaust Emission Abatement Systems (1 July 2018)

Where a vessel is fitted with an exhaust emission abatement system and the optional vessel notations detailed under 1/9.3 through 1/9.9 of the *ABS Guide for Exhaust Emission Abatement* are not requested, the installed exhaust emission abatement system is to comply with the minimum requirements prescribed in Section 1, Table 1 of the Guide and is to be verified by an ABS Surveyor during installation. This is applicable to new construction and existing vessel conversions.

13 Crankcase Ventilation and Drainage

13.1 General

Crankcase ventilation is to be provided in accordance with engine manufacturer's recommendations. Ventilation of the crankcase or any arrangement which could produce a flow of external air into the crankcase is, in general, to be avoided, except for dual fuel engines where crankcase ventilation is to be provided in accordance with 5C-13-10/3.1.13 or 5C-8-A7/3.5. Vent pipes, where provided, are to be as small as practicable to minimize the inrush of air after a crankcase explosion. If a forced extraction of the oil mist atmosphere in the crankcase is provided (for oil mist detection purposes, for example), the vacuum in the crankcase is not to exceed 2.5 mbar (2.55 mkgf/cm², 36.26 mpsi).

13.3 Crankcase Vent Piping Arrangement

13.3.1 General Arrangements

Crankcase ventilation piping is not to be directly connected with any other piping system. The crankcase ventilation pipe from each engine is normally to be led independently to the weather. However, manifold arrangements in accordance with 4-6-5/13.3.2 may also be accepted.

13.3.2 Manifold Arrangements

Where a manifold is employed, its arrangements are to be as follows:

- i) The vent pipe from each engine is to:
 - Run independently to the manifold, and
 - Be fitted with a corrosion resistant flame screen within the manifold.
- ii) The manifold is to be located as high as practicable so as to allow a substantial length of piping separating the crankcases. It is not to be located lower than one deck above the main deck.
- iii) The manifold is to be accessible for inspection and maintenance of the flame screens.
- iv) (2003) The manifold is to be vented to the weather, such that the clear open area of the vent outlet is not less than the aggregate area of the individual crankcase vent pipes entering the manifold.
- v) The manifold is to be provided with drainage arrangements.

13.5 Crankcase Drainage

No interconnections are allowed between drain pipes from crankcases. Each drain pipe is to be led separately to the drain tank and is to be submerged at its outlet, see 4-6-5/5.3.8.

15 Storage and Use of SCR Reductants

Where a Selective Catalytic Reduction (SCR) system is to be installed as a NO_x Reducing Device using urea based ammonia (e.g., 40%/60% urea/water solution), it is to comply with the requirements in 3/11.3 of the *ABS Guide for Exhaust Emission Abatement*, and the same is to be verified by ABS.

PART

4

CHAPTER 6 Piping Systems

SECTION 6 Piping Systems for Steam Plants

1 General

Part 4, Chapter 6, Section 6 (referred to as Section 4-6-6) contains requirements for piping systems associated with the operation of boilers, steam turbines and associated reduction gears intended for propulsion, electric power generation, heating and other services. These systems include steam, condensate, feed water, fuel oil for boiler, lubricating oil, cooling and exhaust gas.

The provisions of this section address system requirements. Additional requirements not specifically addressed in this section, such as plans to be submitted, piping material, design, fabrication, testing, general installation details and component certification, are given in Section 4-6-1, Section 4-6-2, and Section 4-6-3.

3 Steam Piping System

3.1 General

3.1.1 Application

The provisions of 4-6-6/3 apply to steam piping external to propulsion and auxiliary boilers. It includes piping conveying steam to steam turbines, steam heaters, auxiliary steam turbines, etc. Provisions for boilers and piping internal to boilers, as well as mounting on the boilers, such as safety valve, main steam valve, level gauge, etc., are in Part 4, Chapter 4.

3.1.2 Basic Requirement

The intent of the provisions of 4-6-6/3 is to provide for adequate design of steam piping for the intended pressures and temperatures, and mechanical loads such as thermal expansion and contraction.

3.3 Steam Piping Components

3.3.1 Pipes and Fittings

3.3.1(a) Pipes. Pipes are to meet the general requirements of certification in 4-6-1/7.1; materials in 4-6-2/3; and design 4-6-2/5.1. Plastic pipes may be used in an auxiliary steam system of 7 bar (7 kgf/cm², 100 psi) or less, in accordance with 4-6-3/Table 1. Pipes passing through fuel oil and other oil tanks are to be of steel, except that other materials may be considered where it is demonstrated that the material is suitable for the intended service.

3.3.1(b) Pipe fittings and joints. Pipe fittings and joints are to meet the general requirements of certification in 4-6-1/7.1; materials in 4-6-2/3; and design in 4-6-2/5.5 and 4-6-2/5.15, subject to limitations indicated in 4-6-6/Table 1. Plastic pipe fittings and joints for low pressure systems indicated in 4-6-6/3.3.1(a) are to be in accordance with the provisions of Section 4-6-3.

TABLE 1
Joint Limitations for Steam Piping Systems

<i>Types of joint</i>	<i>Class I</i>	<i>Class II</i>	<i>Class III</i>
Butt welded joint	No limitation	No limitation	No limitation
Socket welded joint ⁽¹⁾	Max. 80 mm (3 in.)	Max. 80 mm (3 in.)	No limitation
Slip-on welded sleeve joint ⁽²⁾	Max. 80 mm (3 in.)	Max. 80 mm (3 in.)	No limitation
Flanged joint ⁽³⁾	Types A, B & G only. For type B, < 150 mm (6 in.) and ≤ 400°C (752°F) For type G, see 4-6-2/Table 7	Types A, B, C, D & G only. For type D, ≤ 250°C (482°F) For type G, see 4-6-2/Table 7	Types A, B, C, D & G only. For type G, see 4-6-2/Table 7
Taper-thread joint	≤ 80 mm (3 in.) or ≤ 495°C (923°F). Permissible pressure/size: see 4-6-2/5.5.5(a)	As Class I	No limitation
Compression couplings	≤ 60 mm (2.4 in.) OD	As Class I	No limitation
Metallic bellow type expansion joint	No limitation	No limitation	No limitation
Slip-on joints	Not permitted	Not permitted ⁽³⁾	See Note 3

Notes:

- 1 See 4-6-2/5.5.2 for further operational limitations.
- 2 See 4-6-2/5.5.3 for further operational limitations.
- 3 See 4-6-2/Table 7 for limitations of slip-on flange conforming to ASME B16.5.
- 4 See 4-6-2/5.9 for further limitations.

Pipe sizes are nominal pipe size unless where indicated otherwise.

3.3.2 Valves

Valves are to meet the general requirements of certification in 4-6-1/7.1, materials in 4-6-2/3; and design in 4-6-2/5.11 and 4-6-2/5.13. For valves attached to boilers, including bypass valves where required by 4-4-1/9.5.2, see 4-4-1/9.3.2 for limitation on valve materials.

3.5 Steam Piping Design

Steam piping is to be designed to withstand the internal pressures and temperatures of the system, in accordance with 4-6-2/5.1.1. In addition, it is to be designed to take account of ample expansion and contraction without causing undue strain on the piping system components. Where design temperature exceeds 427°C (800°F), a thermal-expansion stress analysis is to be carried out, in accordance with 4-6-6/3.7.

3.7 Steam Piping Exceeding 427°C (800°F) Design Temperature

3.7.1 Plans and Data to be Submitted

3.7.1(a) Isometric diagram. A completely dimensioned one-line isometric drawing of the piping system is to be submitted, including all data used in making the thermal expansion stress analyses.

3.7.1(b) Thermal-expansion stress analysis. A thermal expansion stress analysis of the piping system is to be conducted and submitted for review. Consideration is to be given to the possibility of excessive reactions on attached equipment or flange joints, and to the possibility that, because of severe service conditions or special configurations, excessive local strains may occur in the piping system due to expansion loading. Provisions are to be made by cold-springing or redesign of the piping system, where necessary, to avoid excessive local strains or excessive reactions on attached equipment or flanged joints. The arrangement of hangers and braces is to be such as to provide adequate support of the piping without interference with thermal expansion, except as expressly considered in the flexibility calculations.

3.7.1(c) *Computer analysis.* Where thermal expansion stress analyses are performed by computer, data submitted is to include combined expansion stresses for each piece of pipe, forces and moments at anchor points, and a printout of input data including thermal expansion coefficients, elastic moduli and anchor movements. Sketches used in preparing the piping systems for computer solution are also to be submitted for information. The data may be submitted in an electronic file format.

3.7.2 Expansion Stresses

Calculations for the expansion stresses are to be made from the following equations:

$$S_E = \sqrt{S_b^2 + 4S_t^2}$$

$$S_b = \frac{\sqrt{(iM_{bp})^2 + (iM_{bt})^2}}{Z}$$

$$S_t = \frac{KM_t}{2Z}$$

where

S_E	=	computed expansion stress; N/mm ² (kgf/mm ² , lbf/in ²)
S_b	=	resultant bending stress; N/mm ² (kgf/mm ² , lbf/in ²)
S_t	=	torsional stress; N/mm ² (kgf/mm ² , lbf/in ²)
i	=	stress intensification factor, see 4-6-6/3.7.4.
M_{bp}	=	bending moment in plane of member; kN-m (kgf-mm, lbf-in)
M_{bt}	=	bending moment transverse to plane of member; kN-m (kgf-mm, lbf-in)
M_t	=	torsional moment; kN-m (kgf-mm, lbf-in)
Z	=	section modulus of pipe; mm ³ (in ³)
K	=	10 ⁶ (1.0, 1.0), for SI (MKS and US) units of measure, respectively

The computed expansion stresses S_E is not to exceed the allowable range of stress S_A obtained from the following equation:

$$S_A = 1.25S_c + 0.25S_h$$

where S_c = allowable stress in cold condition; and S_h = allowable stress in hot condition. These allowable stresses are to be taken from 4-6-2/Table 1.

The sum of the longitudinal stresses due to pressure, weight and other sustained external loading is not to exceed S_h . Where the sum of these stresses is less than S_h , the difference between S_h and this sum may be added to the term $0.25S_h$ in the above equation.

3.7.3 Moments

The resultant moments, M_{bp} , M_{bt} , and M_t , are to be calculated on the basis of 100% of the thermal expansion, without allowance for cold-springing, using the modulus of elasticity for the cold condition.

3.7.4 Stress-intensification Factors

For pipe bends or welded elbows, the stress-intensification factor i may be taken as:

$$i = \frac{0.9}{h^{2/3}}$$

and is in no case to be taken as less than unity, where the flexibility characteristics h is obtained from the following equation:

$$h = \frac{tR}{r^2}$$

where

t	=	nominal pipe wall thickness; mm (in.)
R	=	nominal radius of bend; mm (in.)
r	=	nominal radius of pipe; mm (in.)

For other components, the stress intensification factor is to be in accordance with the best available data.

3.9 General Installation Details

Steam pipes for propulsion and auxiliary services and steam exhaust pipes are not to be led through cargo holds. Where this is not practicable, pipes may be led through the cargo holds, provided they are adequately secured, insulated and situated such as to prevent injuries to personnel and protected from mechanical damage. The joints in the lines are to be kept to a minimum and preferably butt welded. In all cases, the details of arrangement and installation is subject to approval by ABS on a case-by-case basis.

3.11 Steam Piping for Propulsion Turbines

3.11.1 Strainers

Efficient steam strainers are to be provided close to the inlet to the ahead and astern high pressure turbines, or alternatively, at the inlet to the maneuvering valves.

3.11.2 Water Accumulation and Drain

Steam supply piping is to be installed such that it will prevent accumulation of water to avoid water hammer. Where this is unavoidable, drains are to be provided to ensure adequate draining of the water from the steam lines.

The drains are to be situated whereby water can be effectively drained from any portion of the steam piping system when the vessel is in the normal trim and is either upright or has a list of up to 5 degrees. These drains are to be fitted with suitable valves or cocks and are to be readily accessible.

3.11.3 Extraction Steam

Where steam is extracted from the turbines, approved means are to be provided to prevent steam entering the turbines by way of the bleeder connections.

3.11.4 Astern Steam Supply

The steam supply to an astern turbine is to be so arranged that it is immediately available when the steam to the ahead turbine is cut-off. This does not prevent the use of a guarding valve in the steam supply line to the astern turbine if this valve is operable from the same location as the ahead and astern control valves location.

3.11.5 Devices for Emergency Operation of Propulsion Steam Turbines

In single screw ships fitted with cross compound steam turbines, the arrangements are to be such as to enable safe navigation when the steam supply to any one of the turbines is required to be isolated. For this emergency operation purpose, the steam may be led directly to the L.P. turbine and either the H.P. or M.P. turbine can exhaust directly to the condenser. Adequate arrangements and controls are to be provided for these operating conditions so that the pressure and temperature of the steam will not exceed those which the turbines and condenser can safely withstand. The necessary pipes and valves for these arrangements are to be readily available and properly marked.

A fit up test of all combinations of pipes and valves is to be performed prior to the first sea trials. The permissible power/speeds when operating without one of the turbines (all combinations) is to be specified and information provided on board.

The operation of the turbines under emergency conditions is to be assessed for the potential influence on shaft alignment and gear teeth loading conditions.

3.13 Steam Piping for Auxiliary Turbines and Other Services

3.13.1 Steam Availability for Essential Auxiliaries

The arrangements of steam piping are to be such that steam is made available at all times for turbo-generators and other auxiliaries essential for propulsion and safety.

3.13.2 Water Accumulation and Drainage

The requirements of 4-6-6/3.11.2 are also applicable for the steam supply lines to the auxiliaries.

3.13.3 Relief Valves

Where steam piping may receive steam from any source at higher pressure than that for which it is designed, or where auxiliary steam piping is not designed to withstand boiler pressure, a suitable reducing valve, relief valve and pressure gauge are to be fitted. The safety valve installed is to have sufficient discharge capacity to protect the piping against excessive pressure.

3.13.4 Steam Heating System

3.13.4(a) Steam heating system for fuel oil tanks. Steam heating arrangements of fuel oil tanks, temperature control and alarms, and provision of observation tanks are to be in accordance with 4-6-4/13.5.7.

3.13.4(b) Steam heaters. Steam heater housing, temperature control and alarm and fitting of relief valves, are to be in accordance with 4-6-4/13.7.4.

3.15 Blow-off Piping

Blow-off piping is to be designed to a pressure of at least 1.25 times the maximum allowable working pressure of the boiler or the maximum allowable working pressure plus 15.5 bar (15.8 kgf/cm², 225 psi), whichever is less.

Where blow-off pipes of two or more boilers are connected to a common discharge, a non-return valve is to be provided in the piping from each boiler.

3.17 System Monitoring

Propulsion machinery spaces intended for centralized or unattended operations (**ACC/ACCU** notation) are to be provided with system alarms, displays and shutdowns as in 4-9-6/Table 2 and 4-9-6/Table 5A for propulsion steam and 4-9-6/Table 5B and 4-9-6/Table 6 for auxiliary steam.

3.19 Testing and Trials

Hydrostatic tests are to be in accordance with 4-6-2/7.3.1 and 4-6-2/7.3.3. The system is to be tried under working condition in the presence of a Surveyor.

5 Boiler Feed Water and Condensate Systems

5.1 General

5.1.1 Definitions

Boiler feed water is distilled or fresh water used in boilers for generation of steam. Condensate is water derived from condensed steam.

5.1.2 Application

The provisions of 4-6-6/5 apply to feed water and condensate systems of boilers and steam turbines intended primarily for propulsion and auxiliary services.

5.1.3 Basic Requirements

The intent of the requirements is to provide:

- Redundancy in feed water supply to boilers of propulsion and power generation boilers;
- Redundant feed water pumps for any boiler so that in the event of the failure of a feed pump, the safety of the boiler is not compromised;
- Safeguard for the integrity of feed water piping;
- Redundant means for condensate circulation.

5.3 Feed Water System Design

5.3.1 Feed Water Piping Design Pressure

Feed water piping between the boiler and the required stop valve and screw down check valve (see 4-6-6/5.5.2 and 4-6-6/5.7.2), including these valves, are to be designed for a pressure not less than the smaller of the following:

- 1.25 times the maximum allowable working pressure of the boiler.
- Maximum allowable working pressure of the boiler plus 15.5 bar (15.8 kgf/cm², 225 psi).

In no case is the feed water piping from the feed water pump to the boiler to be designed to a pressure less than the feed pump relief valve setting or the shutoff head of the feed pump.

5.3.2 Feed Water Supply

Main boilers and auxiliary boilers for essential services are to be provided with a reserve feed water tank. Alternatively, a connection to the domestic fresh-water tanks is to be provided in lieu of the reserve feed water tank.

5.3.3 Automatic Control of Feed

The feed of each boiler is to be automatically controlled by the water level in the boiler. Local manual control of feed is also to be provided. See also 4-4-1/11 for boiler controls.

5.3.4 Feed Water Pumps and Feed Piping

See 4-6-6/5.5 and 4-6-6/5.7.

5.3.5 Feed Water Pipes and Tanks

Feed water pipes are not to be run through oil tanks, nor are oil pipes to pass through boiler feed tanks. Piping connections to feed water tanks are to be arranged to prevent an accidental contamination of the feed water from any salt water. Feed water tanks are not to be located adjacent to fuel oil tanks.

5.5 Propulsion and Electric Power Generation Boilers

5.5.1 Number of Feed Water Pumps

There are to be two means of feeding each boiler intended for propulsion or for electric power generation. The following arrangements of feed pumps are acceptable.

5.5.1(a) Group-feed systems. Group-feed systems are arrangements where all boilers are fed by the same group of pumps. Where two independently driven feed pumps are provided, each is to be dedicated for this purpose only and is to be capable of supplying all of the boilers at their normally required operating capacity. Where more than two feed pumps are provided, the aggregate capacity is to be not less than 200% of that required by all of the boilers at their normally required capacity.

5.5.1(b) Alternative group-feed system. Where one of the feed pumps is driven by propulsion turbine or propulsion shaft, the other is to be independently driven. The capacity of each of these pumps is to be capable of supplying all of the boilers at their normally required capacity. In addition to these pumps, an independently driven feed pump for use in emergency is to be fitted. The capacity of the emergency feed pump is to be sufficient for supplying all of the boilers at three-quarters of their normal operating capacity. The emergency feed pump may be used for other purposes, such as harbor feed water service or other duties, but not in systems likely to have a presence of oil or oil-contaminated water.

5.5.1(c) *Unit-feed systems.* Where two or more boilers are provided and each boiler has its own independently driven feed pump capable of supplying the boiler at its normally required capacity, a standby independently driven feed pump of the same capacity is to be provided, as follows:

- In vessels having two boilers, one such standby feed pump is to be provided for each boiler.
- In vessels having three or more boilers, not more than two boilers are to be served by one of such standby feed pumps.

5.5.2 Feed Piping

5.5.2(a) *Valves.* The feed line to each boiler is to be fitted with a stop valve, in accordance with 4-4-1/9.5.3(b). A stop check valve is to be fitted as close as possible to this stop valve. However, a feed water regulator may be installed between the stop check valve and the stop valve, provided it is fitted with a by-pass as in 4-6-6/5.5.2(c).

5.5.2(b) *Duplicated feed lines.* For group-feed systems, two independent feed lines are to be provided between the pumps and each boiler. However, a single penetration in the steam drum is acceptable. In the case where the two feed lines are combined to form a single penetration at the boiler, the screw down check valve in 4-6-6/5.5.2(a) above is to be installed in each of the two feed lines. For boilers with unit-feed systems and where two or more boilers are installed, a single feed line between the pumps and each boiler will suffice.

5.5.2(c) *By-pass arrangements.* Feed-water regulator and feed-water heaters, where fitted in the feed piping, are to be provided with by-pass arrangements so as to allow their maintenance without interrupting the feed water supply. By-pass for feed-water regulator is not required if it is the full-flow type.

5.7 Other Boilers

5.7.1 Number of Pumps

There are to be at least two feed water pumps having sufficient capacity to feed the boilers at their normally required capacity, with any one pump out of operation. All feed pumps are to be permanently connected for this purpose.

5.7.2 Feed Piping

Each feed line is to be provided with a stop valve at the boiler and a screw down check valve as close as possible to the stop valve. A feed water regulator may be installed between the screw down check valve and the stop valve, provided it is fitted with a by-pass. For boilers essential to support propulsion, such as fuel oil heating, the feed line arrangements are to be as in 4-6-6/5.5.2(b). In such cases, installation having a single boiler is to be fitted with duplicated feed lines.

5.9 Condensate System for Propulsion and Power Generation Turbines

5.9.1 Number of Condensate Pumps

There are to be at least two condensate pumps. One of these pumps is to be independent of the main propulsion machinery.

5.9.2 Observation Tanks

Steam condensate lines from the heaters and heating coils in tanks are to be led to an observation tank to enable detection of possible oil contamination.

5.11 System Components

5.11.1 Pumps

Condensate pumps, feed pumps, and for condensers, condenser vacuum pumps associated with propulsion boilers and propulsion steam turbines are to be certified in accordance with 4-6-1/7.3. Feed pumps are to be fitted with a relief valve, except where the pumps are of the centrifugal type such that the shutoff pressure of the pump cannot exceed the design pressure of the piping.

5.11.2 Condensers, Feed Water Heaters, and Other Heat Exchangers

5.11.2(a) *Certification.* Condensers, feed water heaters and other heat exchangers having either of the following design parameters or applications are to be certified by ABS:

- Design pressure > 6.9 bar (7 kgf/cm², 100 lb/in²) on either side at all design temperatures;
- Design pressure > 1 bar (1 kgf/cm², 15 lb/in²) but ≤ 6.9 bar on either side at design temperature > 149°C (300°F), with vessel internal volume > 0.14 m³ (5 ft³).

Condensers [other than those in 4-6-6/5.11.2(c)] which are subject to pressure, and are essential for propulsion or power generation such as those associated with propulsion turbines but are not required to be certified on basis of above specified criteria, are to be subjected to a hydrostatic test of 1.5 times the design pressure. This hydrostatic test of the condenser is to be conducted with all tubes and ferrules fitted, and in the presence of a Surveyor.

5.11.2(b) *Protection against condenser overpressure.* Any condenser which can be subjected to a pressure greater than its design pressure is to be fitted with a pressure relief valve or burst disc of suitable capacity. These devices may be fitted in the steam piping between the condenser and steam pressure control valve, if they are of suitable capacity and cannot be isolated from the condenser. The venting of such relieving devices is to be to the weather in a location where personnel will not be present. The relief valve or burst disc need not be fitted if a fail-safe automatic means of preventing overpressurization is provided. Such means may be an automatic valve, installed in the steam line upstream of the condenser, which will close upon sensing a preset high pressure in the condenser and which will also automatically close upon failure in its control system or in its operation. Calculations are to be submitted demonstrating that, in the event of a rise in steam pressure to the condenser, the automatic valve will close prior to the condenser pressure exceeding its design pressure

5.11.2(c) *Vacuum condensers.* Condensers which are operated under full or partial vacuum and are essential for propulsion or power generation, such as those associated with propulsion turbines, are to be subjected to a hydrostatic test of 1 bar (1 kgf/cm², 15 psi). This hydrostatic test of the condenser is to be conducted with all tubes and ferrules fitted, and in the presence of the Surveyor.

5.11.3 Pipe Fittings and Joints

Pipe fittings and joints are to meet the requirements for certification in 4-6-1/7.1; materials in 4-6-2/3; and design in 4-6-2/5.5 and 4-6-2/5.15, subject to limitations in 4-6-6/Table 2.

TABLE 2
Pipe Joint Limitations for Feed Water Systems

<i>Pipe joints</i>	<i>Class I</i>	<i>Class II</i>	<i>Class III</i>
Butt welded joint	No limitation	No limitation	No limitation
Socket welded joint ⁽¹⁾	Max. 80 mm (3 in.)	Max. 80 mm (3 in.)	No limitation
Slip-on welded sleeve joint ⁽²⁾	Max. 80 mm (3 in.)	Max. 80 mm (3 in.)	No limitation
Flanged joint	Types A, B & G only. For type G, see 4-6-2/Table 7	Types A, B, C, D & G only. For type G, see 4-6-2/Table 7	Types A, B, C, D & G only. For type G, see 4-6-2/Table 7
Taper-thread joint	≤ 80 mm (3 in.) Permissible pressure/size, see 4-6-2/5.5.5(a)	≤ 80 mm (3 in.) Permissible pressure/size, see 4-6-2/5.5.5(a)	No limitation
Compression couplings	≤ 60 mm (2.4 in.) OD	≤ 60 mm (2.4 in.) OD	No limitation

Notes:

- 1 See 4-6-2/5.5.2 for further operational limitations.
- 2 See 4-6-2/5.5.3 for further operational limitations.

Pipe sizes indicated are nominal diameter, except where specified otherwise.

5.13 System Monitoring

Propulsion machinery spaces intended for centralized or unattended operations (**ACC/ACCU** notation) are to be provided with system alarms, displays and shutdowns as in 4-9-6/Table 2 and 4-9-6/Table 5A for propulsion steam and 4-9-6/Table 5B and 4-9-6/Table 6 for auxiliary steam.

5.15 Testing and Trials

Hydrostatic tests are to be in accordance with 4-6-2/7.3.1 and 4-6-2/7.3.3. The system is to be tried under working condition in the presence of a Surveyor.

7 Boiler Fuel Oil Piping System

7.1 General

7.1.1 Application

The provisions of 4-6-6/7 apply to fuel oil systems of boilers intended for propulsion, power generation, fuel oil and cargo heating, and other services. Requirements for shipboard fuel oil storage, transfer, heating and purification as provided in 4-6-4/13 are to be complied with. System component requirements in 4-6-4/13.7 are applicable here also.

Requirements for fuel oil systems of diesel engines and gas turbines are provided in 4-6-5/3.

7.1.2 Fuel Oil Flash Point

The provisions of 4-6-6/7 are intended for boilers burning fuel oils having a flash point (closed cup test) above 60°C (140°F). Boilers burning fuel oil of a lesser flash point are subject to special consideration. In general, fuel oil with flash point of 60°C or below, but not less than 43°C (110°F), may only be used for vessels classed for services in specific geographical areas. The climatic conditions in these areas are to preclude ambient temperature of spaces where such fuel oil is stored from rising within 10°C (18°F) below its flash point.

Boilers burning liquefied natural gas (LNG) or any other gaseous fuel are to comply with the requirements of Section 5C-8-16.

Boilers burning crude oil as fuel are to comply with the requirements of the *ABS Guide for Burning Crude Oil and Slops in Main and Auxiliary Boilers*.

7.1.3 Basic Requirements

The intent of the requirements of 4-6-6/7 along with those of 4-6-4/13 is to:

- i) Provide for the continuity of fuel oil supply to boilers for propulsion and for power generation, primarily by means of providing redundancy in the system;
- ii) Minimize fire risks brought about by the storage and handling of fuel oil;
- iii) Provide an indication of integrity of propulsion boiler fuel oil service pumps by testing and certification.

Boilers not used for propulsion or power generation, but essential for supporting propulsion and maneuvering functions of the vessel (e.g., heating of heavy fuel oil) and for other safety functions, are to satisfy 4-6-6/7.1.3i) and 4-6-6/7.1.3ii).

Boilers not related to these safety functions (e.g., cargo heating) need only meet 4-6-6/7.1.3ii).

7.3 Fuel Oil Service System for Propulsion Boilers

7.3.1 Fuel Oil Service Pumps

There are to be at least two independently driven fuel oil service pumps. The capacity of the pumps with any one pump out of operation is to be sufficient to supply the boilers at their rated output. The pumps are to be arranged such that one may be overhauled while the other is in service. Fuel oil service pumps are to be fitted with remote means of control situated outside the space in which they are located so that they may be stopped in the event of fire arising in that space.

Fuel oil service pumps for boilers intended for steam propulsion are to be certified in accordance with 4-6-1/7.3.1iii).

7.3.2 Heaters

Where fuel oil heating is required, there are to be at least two heaters having sufficient capacity to supply heated fuel oil to the boilers at their normal operating capacity with any one heater out of operation.

7.3.3 Filters or Strainers

Filters or strainers are to be provided in the suction lines and are to be arranged such that they can be cleaned without interrupting the fuel supply. This may be achieved by installing two such filters or strainers in parallel or installing the duplex type with a changeover facility that will enable cleaning without interrupting the fuel supply. See 4-6-4/13.7.5 for depressurization and venting requirements.

Strainers are to be so arranged and located as to prevent, in the event of leakage, spraying oil onto surfaces with temperature in excess of 220°C (428°F).

7.3.4 Pressure Piping Between Service Pumps and Burners

7.3.4(a) General. Fuel oil piping between service pumps and burners is to be so located as to be easily visible, see 4-6-4/13.3.3. A master valve is to be fitted at the manifold supplying fuel oil to the burners. This valve is to be of the quick closing type and is to be readily operable in an emergency.

7.3.4(b) Pipes. Fuel oil pipes between service pumps and burners are to be extra-heavy steel, and in addition, that pipe between the burner shutoff valves and the burners is to be of a seamless type. However, short flexible connections of appropriate materials (see 4-6-2/5.7) may be used at the burners.

7.3.4(c) Pipe fittings. Pipe fittings and joints are to be in accordance with 4-6-4/13.7.1 except that the following further limitations are applicable to taper-thread joints:

- Connections to valves and equipment may be of taper-thread joints up to 50 mm (2 in.) nominal diameter; and
- Pipe joints using screw unions are not to be used in sizes of 25 mm (1 in.) nominal diameter and over.

7.3.4(d) Automatic burner fuel shutoff. For safety purposes, an alarm is to be given and fuel supply to the boiler burner is to be automatically shut off in the event of flame failure or flame scanner failure; low water level; forced draft failure; boiler control power failure; see 4-4-1/11.5.1.

7.5 Fuel Oil Service System for Boilers Essential for Power Generation, Supporting Propulsion and Habitable Conditions

The requirements of 4-6-6/7.3 are applicable for boilers essential for power generation, supporting propulsion and habitable conditions. Where an exhaust gas boiler is fitted, and arranged such that steam services essential for propulsion can be supplied without the operation of the fuel oil system of the auxiliary boiler, the requirements for dual fuel oil service pumps (4-6-6/7.3.1), dual heaters (4-6-6/7.3.2) and duplex strainers (4-6-6/7.3.3) may be omitted.

7.7 System Monitoring and Shutdown

4-6-6/Table 3 summarizes the required alarms for fuel oil systems in 4-6-4/13 and 4-6-6/7.

TABLE 3
Fuel Oil System Alarms and Shutdown

<i>Equipment</i>	<i>Requirement</i>	<i>Reference</i>
Overflow tank	High-level alarm	4-6-4/13.5.4
Fuel oil tank	High-level alarm, unless overflow is fitted	4-6-4/13.5.6(e)
Fuel oil heaters	High-temperature alarm unless heating medium precludes overheating.	4-6-4/13.5.7(b) and 4-6-4/13.7.4(b)
Fuel oil pumps	Remote manual shutdown	4-6-6/7.3.1
Fuel oil supply to burners	Automatic shutoff and alarms for specified conditions	4-6-6/7.3.4(d)

Propulsion machinery spaces intended for centralized or unattended operation are to be fitted with additional alarms and with automatic safety system functions. See 4-9-6/Table 5A and 4-9-6/Table 5B for propulsion and auxiliary boilers, respectively.

7.9 Testing and Trials

Hydrostatic tests are to be in accordance with 4-6-2/7.3.1 and 4-6-2/7.3.3. The system is to be tried under working condition in the presence of a Surveyor.

9 Lubricating Oil Systems for Steam Turbines and Reduction Gears

9.1 General

9.1.1 Application

The provisions of 4-6-6/9 apply to lubricating oil systems of steam turbines and associated reduction gears intended for propulsion and power generation. Requirements for lubricating oil storage and transfer systems in 4-6-4/15 are to be complied with, as appropriate. System component requirements in 4-6-4/15.5 are applicable here also.

9.1.2 Basic Requirement

The intent of the requirements for lubricating oil service system in 4-6-6/9 and 4-6-4/15 is to:

- Provide for continuity of supply of lubricating oil to propulsion machinery by means of redundancy in the lubricating oil system;
- Provide warning of failure of the lubricating oil system and other measures to prevent rapid deterioration of propulsion and power generation machinery;
- Minimize the possibility of fire due to lubricating oil.

9.1.3 Vessel Inclination (1 July 2018)

The lubricating oil systems and the associated equipment are to have the capability of satisfactory operation when the vessel is inclined at the angles indicated in 4-1-1/7.9. **Consideration is to be given to all acceptable fill levels in the lube oil sumps and tanks for compliance with this requirement.**

9.1.4 Dedicated Piping

The lubricating oil piping, including vents and overflows, is to be entirely separated from other piping systems.

9.3 Lubricating Oil Systems for Propulsion Turbines and Gears

9.3.1 Lubricating Oil Pumps

9.3.1(a) Turbines. Pressure or gravity lubricating system is to be provided with at least two lubricating oil pumps, at least one of which is to be independently driven. The capacity of the pumps with any one pump out of service is to be sufficient for continuous operation of the turbine at rated power. For multiple turbine installations, one or more independently driven standby pumps is to be provided such that all turbines can be operated at rated power in the event of any one lubricating oil pump for normal service being out of service.

9.3.1(b) Reduction gears. Where the lubricating oil system of the propulsion reduction gear is independent of that of the propulsion turbine, it is to be provided with lubricating oil pumps as in 4-6-6/9.3.1(a).

9.3.1(c) Attached pumps. Where the size and the design of the reduction gear is such that lubrication before starting is not necessary and a self-driven attached pump is used, the independently driven standby pump is not required if a complete duplicate of the attached pumps is carried onboard. This alternative, however, is only permitted for multiple-propeller installations, or similar, where one of the propulsion gear is inoperable while its pump is being changed without completely disrupting the propulsion capability of the vessel.

9.3.1(d) Certification. Lubricating oil pumps associated with the propulsion steam turbine and reduction gears are to be certified in accordance with 4-6-1/7.3.

9.3.2 Automatic Steam Shutoff

To prevent rapid deterioration of the turbine or the gear upon dangerous lowering of pressure in the lubricating oil system of the turbine or the gear, means are to be fitted to automatically shut off the steam supply to the turbine through a quick acting device. The activation of this device is to be alarmed at propulsion control stations. The steam shutoff is not to prevent the admission of steam to the astern turbine for braking purposes.

9.3.3 Emergency Lubricating Oil Supply

In addition to 4-6-6/9.3.1 and 4-6-6/9.3.2, an emergency supply of lubricating oil is to be provided which will automatically come into operation upon failure of the lubricating oil system. This emergency supply may be from a gravity tank (see also 4-6-6/9.5), provided that it contains sufficient oil to maintain satisfactory lubrication until the turbines are brought to rest. If an independently driven lubricating oil pump or other means of oil supply is used for this purpose, it must not be affected by the loss of electrical power supply.

9.3.4 Lubricating Oil Failure Alarms

Audible and visual alarms are to be fitted for each lubricating oil system serving propulsion turbines and reduction gears to warn of the failure of the lubricating oil system.

9.3.5 Lubricating Oil Coolers

Lubricating oil coolers with means for controlling the oil temperature are to be provided. Lubricating oil coolers are to be fitted at least with means to determine oil temperature at the outlet.

9.3.6 Filters and Strainers

A magnetic strainer and a fine mesh filter are to be fitted in the lubricating oil piping to the turbines and the reduction gears. Each filter and strainer is to be of the duplex type or otherwise arranged so that it may be cleaned without interrupting the flow of oil.

Strainers and filters are also to be arranged and located so that, in the event of leakage, oil will not spray onto surfaces with temperature in excess of 220°C (428°F). See 4-6-4/13.7.5 for depressurization and venting requirements.

9.3.7 Purifiers

A purifier of the mechanical type is to be provided for separation of dirt and water from the lubricating oil in systems containing more than 4.0 m³ (4000 liters, 1057 gallons) of lubricating oil.

9.5 Lubricating Oil Tanks

In addition to 4-6-4/15.3, for lubricating oil tanks in general, where gravity tanks are utilized for lubrication, these tanks are to be provided with a low-level alarm and the overflow lines from these tanks to the sump tanks are to be fitted with a sight flow glass. Level gauges are to be provided for all gravity tanks and sumps.

9.7 Lubricating Oil Systems for Auxiliary Steam Turbines

9.7.1 Lubricating Oil Pumps

A standby lubricating oil pump is not required for generator turbines.

9.7.2 Lubricating Oil System Alarm

Audible and visual alarms for failure of the lubricating oil system are to be fitted.

9.7.3 Automatic Shutoff

Generator turbines are to be fitted with means to automatically shut off the turbine steam supply upon failure of the lubricating oil system.

9.7.4 Strainers and Filters

Requirements in 4-6-6/9.3.6 are applicable. However, in multiple-generator installations, each turbine may be fitted with simplex strainer and/or filter, provided the arrangements are such that the cleaning can be performed without affecting full propulsion capability.

9.9 System Monitoring and Safety Shutdown

4-6-6/Table 4 summarizes the basic alarms of the lubricating oil system and safety shutdowns, as required by 4-6-6/9.

TABLE 4
Lubricating Oil System Alarms and Safety Shutdown

<i>Equipment</i>	<i>Requirement</i>	<i>Reference</i>
Lub. oil system for turbines and gears – propulsion and auxiliary	Failure alarm	4-6-6/9.3.4 and 4-6-6/9.7.2
Propulsion turbines and gear and auxiliary turbine	Shutdown in case of turbine or gear lub. oil system failure	4-6-6/9.3.2 and 4-6-6/9.7.3
Lub. Oil gravity tank	Low level alarm	4-6-6/9.5

Propulsion machinery spaces intended for centralized or unattended operation are to be fitted with additional alarms and automatic safety system functions. See e.g., 4-9-6/Table 2 for propulsion turbine and gear and 4-9-6/Table 6 for generator turbine.

9.11 Testing and Trials

Hydrostatic tests are to be in accordance with 4-6-2/7.3.1 and 4-6-2/7.3.3. The system is to be tried under working condition in the presence of a Surveyor.

11 Sea Water Circulation and Cooling Systems

11.1 General

11.1.1 Application

The provisions of 4-6-6/11 apply to condenser cooling systems and to lubricating oil cooling water systems for steam turbines and associated reduction gears.

11.1.2 Basic Requirements

The intent of the requirements for cooling systems is to provide continuity of supply of cooling medium.

11.3 Condenser Cooling System

11.3.1 Circulating Pumps

In addition to the main circulating pump, an emergency means of circulating water through the condenser is to be provided and may consist of a connection from an independent power pump. Independent sea suction is to be provided for each of these pumps. A cross connection between circulating pumps in multiple-unit installations will be acceptable in lieu of an independent power-pump connection.

11.3.2 Sea Inlet Scoop

Where sea inlet scoop circulation is provided for the condenser, at least one independent circulating pump is to be fitted for use during low vessel speed. In addition, a permanent connection to the largest pump in the machinery spaces is to be provided as a second means of circulation during low vessel speed.

For propulsion machinery spaces intended for centralized or unattended operation (**ACC** or **ACCU** notation), the independent circulating pump is to be arranged for automatic starting.

11.5 Lubricating Oil Cooling Systems

11.5.1 Lubricating Oil Coolers and Cooling Water Pumps

For propulsion turbines and associated reduction gears, one or more lubricating oil coolers with means for controlling the oil temperature is to be provided together with at least two separate cooling water pumps. At least one of the pumps is to be independently driven. The coolers are to have sufficient capacity to maintain the required oil temperature while the propulsion plant is operating continuously at its rated power.

11.5.2 Indicators

Indicators are to be fitted by which the pressure and temperature of the water inlet and oil outlet of the coolers may be determined.

11.7 Cooling System Components

11.7.1 Pumps

Main circulating pumps (i.e., condenser cooling water pumps) are to be certified in accordance with 4-6-1/7.3.

11.7.2 Heat Exchangers

11.7.2(a) Certification. See 4-6-6/5.11.2 for heat exchangers required to be certified by ABS.

11.7.2(b) Lubricating oil coolers. The requirements of 4-6-4/15.5.4 for lubricating oil coolers for internal combustion engines apply.

11.7.3 Molded Nonmetallic Expansion Joints

Molded nonmetallic expansion joints, where used, are to be of an approved type. See 4-6-2/5.8.

11.9 System Monitoring

Propulsion machinery spaces intended for centralized or unattended operations (**ACC/ACCU** notation) are to be fitted with monitoring and safety system functions. See e.g., 4-9-6/Table 2 for propulsion turbines and gears and 4-9-6/Table 6 for generator turbines.

11.11 Testing and Trials

Hydrostatic tests are to be in accordance with 4-6-2/7.3. The system is to be tried under working condition in the presence of a Surveyor.

13 Exhaust Gas Piping

The requirements of 4-6-5/11 for exhaust gas piping of internal combustion engines apply.

PART

4

CHAPTER 6 Piping Systems

SECTION 7 Other Piping Systems

1 General

Part 4, Chapter 6, Section 7 (referred to as Section 4-6-7) covers provisions for piping systems not covered in Section 4-6-4, Section 4-6-5 and Section 4-6-6. It includes fluid power piping systems, helicopter refueling piping systems and oxygen-acetylene piping systems. The provisions of Section 4-6-1, Section 4-6-2 and Section 4-6-3 apply to piping systems in Section 4-6-7.

3 Hydraulic Oil Systems

3.1 Application

The provisions of 4-6-7/3 apply to all shipboard hydraulic oil systems. Hydraulic oil systems fitted in self-contained equipment not associated with propulsion and maneuvering of the vessel (e.g., a crane) and completely assembled by the equipment manufacturer need not comply with this subsection. Such hydraulic oil systems, however, are to comply with the accepted industry standards.

Hydraulic oil systems essential for the propulsion and maneuvering of the vessel are subject to further requirements. Controllable pitch propeller hydraulic system and steering gear hydraulic systems are also to comply with the requirements in Section 4-3-3 and Section 4-3-4, respectively.

Hydraulic oil systems associated with remote propulsion control are also to comply with 4-9-2/5.5 for, among other requirements, duplication of hydraulic pumps. The same systems associated with propulsion machinery spaces intended for centralized or unattended operation (**ACC/ACCU/ABCU** notation) are also to meet the provisions of 4-9-9/9 for, among other requirements, flash point of hydraulic fluid.

3.3 Hydraulic Oil Storage Tanks

3.3.1 Location of Storage Tanks

Hydraulic oil tanks are not to be situated where spillage or leakage therefrom can constitute a hazard by falling on heated surfaces in excess of 220°C (428°F).

3.3.2 Tank Vents

Hydraulic tank vents are to meet the provisions of 4-6-4/9. Vents from hydraulic oil tanks, other than double bottom or similar structural tanks, may be terminated in machinery and other enclosed spaces provided that their outlets are so located that overflow therefrom will not impinge on electrical equipment, heated surfaces or other sources of ignition; see 4-6-4/9.3.4(c). Tank vents of hydraulic systems utilized for actuation of valves located in cargo oil tanks are, however, to be terminated in the weather; see 5C-1-7/3.5.3.

3.3.3 Means of Sounding

A means of sounding is to be fitted for each hydraulic oil tank; such means is to meet the provisions of 4-6-4/11. Tubular gauge glasses may be fitted to hydraulic oil tanks, subject to conditions indicated in 4-6-4/11.5.2(b) and 4-6-4/11.5.2(c).

3.5 Hydraulic System Components

3.5.1 Pipes and Fittings

Pipes, pipe fittings and joints are to meet the general requirements of certification in 4-6-1/7.1 (except that ABS certification is not required for all classes of hydraulic piping); materials in 4-6-2/3; and design in 4-6-2/5, subject to limitations in 4-6-7/Table 1.

TABLE 1
Pipe Joint Limitations for Hydraulic Piping

<i>Types of joint</i>	<i>Class I</i>	<i>Class II</i>	<i>Class III</i>
Butt welded joint	No limitation	No limitation	No limitation
Socket welded joint ⁽¹⁾	Max. 80 mm (3 in.)	Max. 80 mm (3 in.)	No limitation
Slip-on welded sleeve joint ⁽²⁾	Max. 80 mm (3 in.)	Max. 80 mm (3 in.)	No limitation
Flanged joint ⁽³⁾	Types A, B & G only. For type B, ≤ 400°C (752°F) For type G, see 4-6-2/Table 7	Types A, B, C, D & G only. For type D, ≤ 250°C (482°F). For type G, see 4-6-2/Table 7	Types A, B, C, D & G only. For type G, see 4-6-2/Table 7
Taper-thread joint ⁽⁴⁾	≤ 80 mm (3 in.), or ≤ 495°C (923°F), permissible pressure/size: see 4-6-2/5.5.5(a).	As for Class I	No limitation.
Straight thread O-ring joint	Straight thread O-ring type fittings may be used for pipe connection to equipment such as pumps, valves, cylinders, accumulators, gauges and hoses, without size and pressure limitations. However, such fittings are not to be used for connecting sections of pipe.		
Compression couplings ⁽⁵⁾	≤ 60 mm (2.4 in.) OD.	As for Class I	No size limitation.
Hoses	Subject to fire resistance test. See 4-6-2/5.7.3(c)	As for Class I	As for Class I
Molded non-metallic expansion joint	Not permitted	Not permitted	Not permitted
Molded expansion joint of composite construction	Subject to compliance with 4-6-2/5.8.1	Subject to compliance with 4-6-2/5.8.1	Subject to compliance with 4-6-2/5.8.1
Slip-on Joints	Not permitted	Not permitted	See Note 5

Pipe sizes indicated are nominal pipe size unless specified otherwise.

Notes:

- 1 See 4-6-2/5.5.2 for further operational limitations.
- 2 See 4-6-2/5.5.3 for further operational limitations.
- 3 Split flanges are not permitted in steering gear system, certified thruster systems, nor in systems which are vital to the propulsion or safety of the vessel, and are subject to special consideration in other cases.
- 4 Taper-thread joints up to 80 mm (3 in.) may be used without pressure limitation for pipe connection to equipment, such as pumps, valves, cylinders, accumulators, gauges and hoses. When such joints are used to connect sections of pipe, they are to be in accordance with limitations shown. However, hydraulic systems for the following services are to comply with the stated limitations in all respects [see 4-6-2/5.5.5(b) and 4-6-2/5.5.5(c)]:
 - Steering gear hydraulic systems.
 - Controllable pitch propeller hydraulic systems.
 - Hydraulic systems associated with propulsion or propulsion control.
- 5 See 4-6-2/5.9 for further limitations

3.5.2 Hoses

Hoses are to comply with the requirements of 4-6-2/5.7 for flammable fluid service.

3.5.3 Valves

Valves are to meet the general requirements of certification in 4-6-1/7.1; materials in 4-6-2/3; and design in 4-6-2/5.11 and 4-6-2/5.13. Directional valves are to be treated as pipe fittings and are subject to pressure, temperature and fluid service restrictions specified by the manufacturers.

3.5.4 Hydraulic Accumulators

Welded hydraulic accumulators having operating pressures above 6.9 bar (7 kgf/cm², 100 psi) are to be certified in accordance with Section 4-4-1 as pressure vessels regardless of their diameters.

Accumulators of extruded seamless construction are to be designed, manufactured and tested in accordance with a recognized standard for this type of pressure vessel. Their acceptance will be based on their compliance with the standard as verified by either ABS or an agency recognized by a national authority (in the country of manufacture) having jurisdiction over the safety of such pressure vessels. The certificate of compliance, traceable to the cylinder's serial number, is to be presented to the Surveyor for verification in each case.

Each accumulator which may be isolated from the system is to be protected by its own relief valve or equivalent. Where a gas charging system is used, a relief valve is to be provided on the gas side of the accumulator.

3.5.5 Hydraulic Power Cylinder

3.5.5(a) General. Hydraulic cylinders subject to Classes I and II fluid pressures and temperatures as defined in 4-6-1/Table 1 are to be designed, constructed and tested in accordance with a recognized standard for fluid power cylinders. Acceptance will be based on the manufacturer's certification of compliance and on verification of permanent identification on each cylinder bearing the manufacturer's name or trademark, standard of compliance and maximum allowable working pressure and temperature.

3.5.5(b) Non-compliance with a Recognized Standard. As an alternative to 4-6-7/3.5.5(a), hydraulic cylinders subject to Classes I and II fluid pressures and temperatures and which are not constructed to a recognized standard may be accepted based on the following:

- i) Regardless of diameter, the design of the cylinder is to be shown to comply with one of the following:
 - A recognized pressure vessel code,
 - *Section 4-4-1 of the Rules.* For instance, the cylinder is to have a wall thickness not less than that given by equation 2 of 4-4-1A1/3.1, and the cylinder ends are to meet the requirements of flat heads in 4-4-1A1/5.7, or
 - *Verification through burst tests.* Steel cylinders (other than cast steel) are to withstand not less than 4 times the maximum allowable working pressure, while cast steel, cast iron and nodular iron cylinders are to withstand not less than 5 times the maximum allowable working pressure.

Documentation in this regard is to be submitted for review.

- ii) Each individual unit is to be hydrostatically tested to 1.5 times the maximum allowable working pressure (2 times, for cast iron and nodular iron cylinders) by the manufacturer. A test certificate is to be submitted
- iii) Each cylinder is to be affixed with a permanent nameplate or marking bearing the manufacturer's name or trademark and the maximum allowable working pressure and temperature.

3.5.5(c) Materials. The materials of hydraulic power cylinders addressed in 4-6-7/3.5.5(a) and 4-6-7/3.5.5(b) above are to comply with the following:

- i) The materials of a cylinder are to comply with the requirements of the standard or code to which the cylinder is designed and constructed. Where the design is verified through burst tests, the materials of the cylinder are to comply with 4-4-1/3 or other acceptable standards.
- ii) Ordinary cast iron having an elongation of less than 12% is not to be used for cylinders expected to be subjected to shock loading.
- iii) Copies of certified mill test reports are to be made available to the Surveyor upon request.

3.5.5(d) *Rudder Actuators.* Rudder actuators are to comply with the material requirements of 4-3-4/3, be designed in accordance with 4-3-4/7, and to be certified by ABS in accordance with 4-3-4/19.

3.5.5(e) *Cylinders for Class III Piping Systems.* Cylinders subjected to Class III fluid pressures and temperatures may be used in accordance with the manufacturer's rating.

3.5.5(f) *Exemptions.* Fluid power cylinders that do not form part of the vessel's piping systems, machinery or equipment covered in Part 4 of these Rules are exempt from the requirements of 4-6-7/3.5.5. However, those fluid power cylinders which are integrated into piping systems associated with optional classification notations are to comply with the requirements of 4-6-7/3.5.5 and the applicable requirements specified in the pertinent ABS Rules and Guides.

3.7 System Requirements

3.7.1 Fire Precautions

Hydraulic power units, including pumps and other pressurized components, with working pressure above 15 bar (225 psi) installed within machinery spaces are to be placed in separate room or rooms or shielded, as necessary, to prevent any oil or oil mist that may escape under pressure from coming into contact with surfaces with temperatures in excess of 220°C (428°F), electrical equipment or other sources of ignition. Piping and other components are to have as few joints as practicable.

3.7.2 Relief Valves

Relief valves are to be fitted to protect the system from overpressure. The relieving capacity is not to be less than full pump flow with a maximum pressure rise in the system of not more than 10% of the relief valve setting.

3.9 Hydraulic Starting

Hydraulic oil accumulators for starting the main propulsion engines are to have sufficient capacity without recharging for starting the main engines, as required in 4-6-5/9.5.1.

5 Pneumatic Systems

5.1 Application

The requirements of 4-6-7/5 apply to shipboard pneumatic systems for control and actuation services. The requirements for starting air system are in 4-6-5/9. Pneumatic systems fitted in self-contained equipment not associated with the propulsion and maneuvering of the vessel and completely assembled by the equipment manufacturer need not comply with this subsection. Such pneumatic systems, however, are to comply with the accepted practice of the industry.

5.3 Pneumatic System Components

5.3.1 Air Reservoir

Air reservoirs having a design pressure greater than 6.9 bar (7 kgf/cm², 100 lb/in²) are to be certified by ABS (see 4-4-1/1.9, and for accumulators 4-6-7/3.5.4). Air reservoirs are to be fitted with drain connections effective under extreme conditions of trim. Where they can be isolated from the system safety valve, they are to be provided with their own safety valves or equivalent devices.

5.3.2 Pipe Fittings and Joints

Pipe fittings and joints are to meet the requirements for certification in 4-6-1/7.1; materials in 4-6-2/3; and design in 4-6-2/5.5 and 4-6-2/5.15, subject to limitations in 4-6-7/Table 2.

5.3.3 Pneumatic Power Cylinders

The requirements of hydraulic cylinders in 4-6-7/3.5.5 apply also to pneumatic cylinders.

TABLE 2
Pipe Joint Limitations for Pneumatic Systems

<i>Pipe joints</i>	<i>Class I</i>	<i>Class II</i>	<i>Class III</i>
Butt welded joint	No limitation	No limitation	No limitation
Socket welded joint ⁽¹⁾	Max. 80 mm (3 in.)	Max. 80 mm (3 in.)	No limitation
Slip-on welded sleeve joint ⁽²⁾	Max. 80 mm (3 in.)	Max. 80 mm (3 in.)	No limitation
Flanged joint	Types A, B & G For type G, see 4-6-2/Table 7	Types A, B, C, D & G For type G, see 4-6-2/Table 7	Types A, B, C, D & G For type G, see 4-6-2/Table 7
Taper-thread joint	≤ 80 mm (3 in.). Permissible pressure/size, see 4-6-2/5.5.5(a).	≤ 80 mm (3 in.). Permissible pressure/size, see 4-6-2/5.5.5(a).	No limitation
Compression couplings	≤ 60 mm (2.4 in.) OD	≤ 60 mm (2.4 in.) OD	No limitation

Note:

1 See 4-6-2/5.5.2 for further operational limitations.

2 See 4-6-2/5.5.3 for further operational limitations.

Pipe sizes indicated are nominal diameter, except where specified otherwise.

5.5 Pneumatic System Requirements

5.5.1 Pneumatic Air Source

Compressed air for general pneumatic control and actuation services may be drawn from engine starting air reservoirs, in which case, the aggregate capacity of the starting air reservoirs is to be sufficient for continued operation of these services after the air necessary for the required number of engine starts (as specified in 4-6-5/9.5.1) has been used.

For propulsion remote control purposes, pneumatic air is to be available from at least two air compressors. The starting air system, where consisting of two air compressors, may be used for this purpose. The required air pressure is to be automatically maintained. Pneumatic air supplies to safety and control systems may be derived from the same source but are to be by means of separate lines.

5.5.2 Air Quality

5.5.2(a) *General*. Provisions are to be made to minimize the entry of oil or water into the compressed air system. Suitable separation and drainage arrangements are to be provided before the air enters the reservoirs.

5.5.2(b) *Safety and Control Air Systems*. For requirements regarding the quality of the air supplied to safety and control air systems, see 4-9-2/5.7.

5.5.3 Overpressure Protection

Means are to be provided to prevent overpressure in any part of the pneumatic system. This includes water jackets or casing of air compressors and coolers which may be subjected to dangerous overpressure due to leakage into them from air pressure parts.

7 Fixed Oxygen-acetylene Systems

7.1 Application

The provisions of 4-6-7/7.3 apply to oxygen-acetylene installations that have two or more cylinders of oxygen and acetylene, respectively. Spare cylinders of gases need not be counted for this purpose. Provisions of 4-6-7/7.5 and 4-6-7/7.7, as applicable, are to be complied with for fixed installations regardless of the number of cylinders.

7.3 Gas Storage

7.3.1 Storage of Gas Cylinders

7.3.1(a) Storage room. The gas cylinders are to be stored in rooms dedicated for this purpose only. A separate room is to be provided for each gas. The rooms are to be on or above the uppermost continuous deck and are to be constructed of steel. Access to the rooms is to be from the open deck and the door is to open outwards. The boundaries between the rooms and other enclosed spaces are to be gastight. Suitable drainage of the storage room or area is to be provided.

7.3.1(b) Open area. Where no storage room is provided, the gas cylinders may be placed in an open storage area. In such cases, they are to be provided with weather protection (particularly from heavy seas and heat) and effectively protected from mechanical damage. Suitable drainage of the open storage area or area is to be provided

7.3.1(c) Piping passing through storage room or area. Piping systems containing flammable fluids are not to run through the storage room or open storage area

7.3.2 Ventilation of Storage Room

Acetylene gas cylinder storage room is to be fitted with ventilation systems capable of providing at least six air changes per hour based on the gross volume of the room. The ventilation system is to be independent of ventilation systems of other spaces. The space within 3 m (10 ft) from the power ventilation exhaust, or 1 m (3 ft) from the natural ventilation exhaust is to be considered a hazardous area, see 4-8-4/27.3.3iv). The fan is to be of the non-sparking construction, see 4-8-3/11. Small storage spaces provided with sufficiently large openings for natural ventilation need not be fitted with mechanical ventilation.

7.3.3 Electrical Installation in Storage Room

Electrical equipment installed within the acetylene storage room, including the ventilation fan motor, is to be of the certified safe type, see 4-8-4/27.5.4

7.5 Piping System Components

7.5.1 Pipe and Fittings

7.5.1(a) General. In general, all oxygen and acetylene pipes, pipe fittings, pipe joints and valves are to be in accordance with the provisions of Section 4-6-1 and Section 4-6-2, except as modified below.

7.5.1(b) Piping materials. Materials for acetylene on the high-pressure side between the cylinders and the regulator are to be steel. Copper or copper alloys containing more than 65% copper are not to be used in acetylene piping (high or low pressure). Materials for oxygen on the high-pressure side are to be steel or copper. All pipes, both high- and low-pressure sides, are to be seamless.

7.5.1(c) Design pressure. Pipes, pipe fittings and valves on the oxygen high-pressure side are to be designed for not less than 207 bar (211 kgf/cm², 3000 psi). Pipes used on the low-pressure side are to be at least of standard wall thickness.

7.5.1(d) Pipe joints. All pipe joints outside the storage room or open storage area are to be welded.

7.5.1(e) Flexible hoses. Flexible hoses used to connect oxygen or acetylene gas cylinders to a fixed piping system or manifold are to comply with an acceptable standard and be suitable for the intended pressure and service. Further, the internal surface of a hose used to connect an acetylene tank is to be of a material that is resistant to acetone and dimethylformamide decomposition*.

Where a flexible hose is connected from an oxygen cylinder to the piping system or manifold directly (i.e., no intervening pressure regulator), the internal liner of the oxygen hose is to be of a material that has an autoignition temperature of not less than 400°C (752°F) in oxygen*.

* *Note:* Criteria based on ISO 14113:1997 Gas welding equipment – rubber and plastic hoses assembled for compressed or liquefied gases up to a maximum design pressure of 450 bar.

7.5.2 Pressure Relief Devices

Pressure relief devices are to be provided in the gas piping if the maximum design pressure of the piping system can be exceeded. These devices are to be set to discharge at not more than the maximum design pressure of the piping system to a location in the weather, remote from sources of vapor ignition or openings to spaces or tanks. The area within 3 m (10 ft) of the pressure relief device discharge outlet is to be regarded as a hazardous area. The pressure relief devices may be either a relief valve or a rupture disc.

7.5.3 System Arrangements

Where two or more gas cylinders are connected to a manifold, high pressure piping between each gas cylinder and the manifold is to be fitted with a non-return valve. The piping is not to run through unventilated spaces or accommodation spaces. Outlet stations are to be fitted with shutoff valves. Outlet stations are to be provided with suitable protective devices to prevent back flow of gas and the passage of flame into the supply lines.

7.5.4 Gas Cylinders

Gas cylinders are to be designed, constructed and certified in accordance with the provisions of 4-4-1/1.11.4. Each cylinder is to be fitted with a suitable pressure relief device such as a fusible plug or a rupture disc.

The area within 3 m (10 ft) of the pressure relief device discharge outlet from acetylene gas cylinder is to be regarded as a hazardous area.

7.7 Testing

Piping on the oxygen high-pressure side is to be tested before installation to at least 207 bar (211 kgf/cm², 3000 psi) and the piping on the acetylene high-pressure side is to be tested in accordance with Section 4-6-2. The entire system is to be leak-tested with nitrogen or a suitable inert gas after installation. Care is to be taken to cleanse the piping with suitable medium to remove oil, grease and dirt and to blow-through with oil-free nitrogen or other suitable medium before putting the system in service.

9 Helicopter Refueling Systems

9.1 Application

The requirements of 4-6-7/9 are applicable to helicopter refueling facilities for fuel with a flash point at or below 60°C (140°F) close cup test. For fuel with a flash point of above 60°C, the requirements for spill containment in 4-6-7/9.5 hereunder and the requirements for fuel oil storage and transfer systems in 4-6-4/13 are applicable, as appropriate.

9.3 Fuel Storage and Refueling Equipment Area

9.3.1 Isolation

The designated fuel storage and refueling areas are to be isolated from the following:

- Accommodation areas including vent openings;
- Embarkation stations;
- Escape routes;
- Helicopter landing area; and
- Areas containing any source of vapor ignition.

The method of isolation may be by means of a safe and adequate distance or suitably erected barriers capable of preventing the spread of fire.

9.3.2 Hazardous Area

The fuel storage and refueling area is to be permanently marked to identify it as a restricted area where smoking or other naked flame is not permitted. "NO SMOKING" signs are to be displayed. Open spaces within 3 m (10 ft) of the refueling equipment and within 3 m of the storage tank vent outlet are to be regarded as hazardous areas (see 4-8-4/27.3.3).

9.5 Spill Containment

The fuel storage area is to be provided with arrangements whereby fuel spillage can be collected and drained to a safe location. These arrangements are to be at least as provided hereunder.

9.5.1 Coaming

A coaming surrounding the fuel storage tanks, associated piping and the pumping unit is to be provided. The height of this coaming is to be at least 150 mm (6 in.), so as to contain fuel spillage as well as fire extinguishing agents. Where the pumping unit or any other unit such as dispenser/coalescer unit is situated at a remote distance from the fuel storage tank, a separate coaming of the same minimum height is to be provided around each unit.

9.5.2 Drainage

Arrangements for drainage from within the coaming area are to be as follows.

- i) Permanent piping and a suitable holding tank are to be fitted so that drainage can be either led to the holding tank (for draining oil) or discharged overboard (for draining water) through a three-way valve. No other valve is permitted in the drain piping.
- ii) The cross sectional area of the drain pipe from the fuel tank coaming is to be twice that of the fuel storage tank outlet pipe.
- iii) The area within the coaming is to be sloped towards the drain pipe.

Where the area within the fuel tank coaming is not provided with drainage arrangements, the height of the coaming is to be sufficient to contain the full volume of the fuel storage tank plus 150 mm (6 in.).

For drainage of a helicopter deck, see 4-6-4/3.9.2.

9.7 Fuel Storage Tanks

9.7.1 Construction

Fuel storage tanks are to be of metallic construction. Mounting, securing arrangements and electrical bonding arrangements are to be submitted for approval.

9.7.2 Tank Valves

Fuel storage tank outlet valves are to be provided with a means of remote closure. Such means is not to be cut off in the event of a fire in the fuel storage and the refueling area. In general, the provisions of 4-6-4/13.5.3 are to be complied with.

9.7.3 Tank Vents and Sounding

In general, the provisions of 4-6-4/9 and 4-6-4/11 are applicable. However, tank vents are to be extended at least 2.4 m (8 ft) above the weather deck. Other venting arrangements will be considered.

9.9 Refueling Pumps

The refueling pump is to incorporate a device that will prevent overpressurization of the delivery hose or of the filling hose. A relief valve, where fitted, is to discharge either to the suction side of the pumps or to the storage tanks. Means are to be provided for remote stopping of the refueling pumps from a position not likely to be cut off in the event of a fire in the fuel storage and refueling area.

9.11 Fuel Piping

The refueling pump is to be arranged to connect to only one tank at a time. Piping between the refueling pump and the tank is to be as short as practicable and protected against damage. Fuel piping is to be of steel or equivalent material and to comply with the provisions of 4-6-4/13.7.1 and 4-6-4/13.7.2. The piping system and all equipment used during refueling operation are to be electrically bonded.

9.13 Fuel Storage and Refueling Systems Installed in Enclosed Spaces

9.13.1 Machinery Spaces

Helicopter refueling facilities for fuel with a flash point of 60°C or less are not to be installed in machinery spaces.

9.13.2 Arrangements of the Enclosed Space

The fuel storage and refueling compartment is to be bounded by gas-tight bulkheads and decks. Access to this compartment is to be from the open deck only, which may be by means of a trunk. There is to be no access to this compartment from other compartments.

9.13.3 Machinery and Electrical Installations

In general, the compartment containing refueling facilities is to be regarded as having the same fire and explosion hazards as ro-ro cargo space, see Section 5C-10-4. Specifically, the following provisions of Section 5C-10-4 are to be met:

- 5C-10-4/3.5.1: for ventilation capacity of the compartment.
- 5C-10-4/3.7.2(a) and 5C-10-4/3.7.2(b): for acceptable certified safe equipment and alternative electrical equipment in the compartment.
- 5C-10-4/3.7.2(c): for exhaust fan and ducting.
- 5C-10-4/3.9.1 and 5C-10-4/3.9.2: for bilge system of the compartment.

9.13.4 Storage Tanks

9.13.4(a) Independent tanks. Independent fuel tanks may be installed in the same compartment as the refueling system. The tank, vents, means of sounding and valves are to comply with 4-6-7/9.7.

9.13.4(b) Structural tanks. Fuel tanks may be integral with the vessel's structure. Cofferdams (see Part 5C, Chapter 2) are to be fitted to separate such fuel tanks from machinery spaces, cargo spaces, accommodation, service spaces and other spaces containing a source of ignition. The compartment containing the refueling equipment, ballast tanks and fuel oil tanks containing fuel oil having a flash point of more than 60°C may be regarded as a cofferdam. Tank vents, means of sounding and outlet valves are to be as in 4-6-7/9.13.4(a). Particular attention is to be directed to the height of the tank vent/overflow with respect to the design head of the tank. Overflows, where fitted, are to comply with 4-6-4/9.5.5.

9.15 Fire Extinguishing System

Fixed fire extinguishing systems are to be fitted to protect helicopter fuel storage and refueling equipment areas (or compartments), in accordance with the provisions of 4-7-2/5.3.2 and 4-7-2/5.3.3.

11 Liquefied Petroleum Gases

11.1 General

Liquefied petroleum gas may be used for cooking and heating on all vessels except passenger vessels. Liquefied petroleum gas systems are to be of the vapor withdrawal type only. Cylinders designed to admit the liquid phase of the gas into any other part of the system are prohibited. All component parts of the system, except cylinders, appliances and low pressure tubing, shall be designed to withstand a pressure of 34 bar (35 kgf/cm², 500 psi) without rupture.

11.3 Storage Cylinders

Cylinders for the storage of liquefied petroleum gases are to be designed and constructed in accordance with a recognized pressure vessel standard.

11.5 Installation and Testing

Where liquefied petroleum gases are used, the installation and testing is to comply with a recognized standard.

CHAPTER 7 Fire Safety Systems

CONTENTS

Text in italics is taken from SOLAS 1974, as amended.

SECTION 1	General Provisions	567
1	Application	567
3	Basic Principles.....	567
5	Organization of Chapter 7.....	568
7	Plans and Data to be Submitted	568
9	<i>Fire Control Plan</i>	569
11	Definitions	569
11.1	A, B or C Class Division	569
11.3	<i>Accommodation Spaces</i>	569
11.5	<i>Public Spaces</i>	570
11.7	<i>Service Spaces</i>	570
11.9	<i>Cargo Spaces</i>	570
11.11	<i>Ro-Ro Cargo Spaces</i>	570
11.13	<i>Weather Deck</i>	570
11.15	<i>Machinery Spaces of Category A</i>	570
11.17	<i>Machinery Spaces</i>	570
11.19	Oil Fuel Unit.....	570
11.21	<i>Control Stations</i>	571
11.23	<i>Continuously Manned Central Control Station</i>	571
11.25	<i>Dangerous Goods</i>	571
13	Piping Systems	571
15	<i>Additional Fixed Fire Extinguishing Systems</i>	571
	FIGURE 1 Organization of Chapter 7.....	568
SECTION 2	Provisions for Specific Spaces.....	572
1	Requirements for Machinery Spaces.....	572
1.1	Spaces Containing Oil-fired Boilers or Oil Fuel Units	572
1.3	<i>Spaces Containing Internal Combustion Machinery</i>	573
1.5	<i>Spaces Containing Steam Turbines or Enclosed Steam Engines</i>	574
1.7	<i>Fire Extinguishing Appliances in Other Machinery Spaces</i>	574
1.9	<i>Machinery Space Openings</i>	574
1.11	Fire Precautions for Fuel Oil, Lubricating Oil and Other Flammable Oils	577
1.13	Propulsion Machinery Spaces Intended for Centralized or Unattended Operation	578

3	Requirements for Accommodation and Service Spaces, and Control Stations	579
3.1	<i>Methods of Structural Fire Protection</i>	579
3.3	<i>Fixed Fire Detection and Fire Alarm Systems; Automatic Sprinkler, Fire Detection and Fire Alarm Systems</i>	579
3.4	<i>Locations Requiring Manually Operated Call Points</i>	580
3.5	Portable Extinguishers.....	580
3.7	Ventilation Systems	580
3.9	<i>Requirements for Gaseous Fuel for Domestic Purposes</i>	581
5	Requirements for Miscellaneous High-risk Spaces	581
5.1	Paint and Flammable Liquid Lockers.....	581
5.3	Helicopter Facilities.....	581
5.5	<i>Deep-fat Cooking Equipment</i>	583
5.7	Furnaces of Thermal Oil Heaters.....	583
5.9	Rotating Machines for Propulsion.....	583
5.11	Spaces Containing Equipment with Oil Filled Capacitors	583
7	Requirements for Cargo Spaces	584
7.1	Dry Cargo Spaces	584
7.3	Dry Cargo Spaces Intended to Carry Dangerous Goods.....	584
7.5	General Cargo Vessels.....	587
7.7	Other Dry Cargo Spaces	587
7.9	Liquid Cargo Spaces and Related Spaces	587
TABLE 1	Dangerous Goods Classes	588
TABLE 2	Dangerous Goods in Limited Quantities	589
TABLE 3	Applicability of the Requirements to Cargo Vessels Carrying Dangerous Goods	590
TABLE 4	Application of the Requirements in 4-7-2/7.3 to Different Classes of Dangerous Goods Except Solid Dangerous Goods in Bulk.....	591

SECTION 3 Fire-extinguishing Systems and Equipment..... 592

1	Fire Main Systems	592
1.1	General.....	592
1.3	<i>Capacity of Fire Pumps</i>	592
1.5	Arrangements of Fire Pumps and of Fire Mains	592
1.7	<i>Diameter and Pressure in the Fire Main</i>	595
1.9	<i>Number and Position of Hydrants</i>	595
1.11	<i>Pipes and Hydrants</i>	595
1.13	Fire Hoses	596
1.15	<i>Nozzles</i>	596
1.17	<i>Water Pumps for Other Fire Extinguishing Systems</i>	597
1.19	<i>International Shore Connection</i>	597
3	Fixed Gas Fire Extinguishing Systems	597
3.1	General.....	597
3.3	CO ₂ Systems	601
3.5	Refrigerated Low-pressure CO ₂ Systems.....	602
3.7	<i>Steam Systems</i>	604

	3.9	<i>Equivalent Fixed Gas Fire-Extinguishing Systems for Machinery Spaces and Cargo Pump Rooms</i>	604
	3.11	Clean Agent Fire Extinguishing Systems.....	605
5		Fixed Foam Fire Extinguishing Systems	606
	5.1	<i>Fixed High-expansion Foam Fire Extinguishing Systems in Machinery Spaces</i>	606
	5.3	<i>Fixed Low-expansion Foam Fire Extinguishing System in Machinery Spaces</i>	607
	5.5	Fixed Foam Fire Extinguishing System Outside Machinery Spaces	607
7		<i>Fixed Pressure Water-spraying and Water-mist Fire Extinguishing Systems in Machinery Spaces</i>	608
	7.1	<i>Fixed Pressure Water-spraying Fire Extinguishing System</i>	608
	7.3	<i>Equivalent Water-mist Fire-extinguishing Systems</i>	608
9		<i>Automatic Sprinkler, Fire Detection and Fire Alarm Systems</i>	608
	9.1	<i>General</i>	608
	9.3	<i>Sources of Power Supply</i>	608
	9.5	<i>Component Requirements</i>	608
	9.7	<i>Installation Requirements</i>	609
	9.9	<i>System Control Requirements</i>	610
11		<i>Fixed Fire Detection and Fire Alarm Systems</i>	611
	11.1	<i>Definitions</i>	611
	11.3	<i>Engineering Specifications</i>	611
	11.5	<i>System Control Requirements</i>	615
13		<i>Sample Extraction Smoke Detection Systems</i>	617
	13.1	<i>General Requirements</i>	617
	13.3	<i>Component Requirements</i>	618
	13.5	<i>Installation Requirements</i>	618
	13.7	<i>System Control Requirements</i>	619
15		Miscellaneous Fire Fighting Equipment.....	619
	15.1	Portable Fire Extinguishers	619
	15.3	Portable Foam Applicators	621
	15.5	Fire-fighter's Outfit.....	622
	15.7	Emergency Escape Breathing Devices (EEBDs)	622
	TABLE 1	Dimensions of International Shore Connection	597
	TABLE 2	Minimum Steel Pipe Wall Thickness for CO ₂ Medium Distribution Piping	598
	TABLE 3	Spacing of Detector	615
	TABLE 4	Equivalent Fire Extinguishers	620
	TABLE 5	Portable and Semi-portable Extinguishers	621
	TABLE 6	Minimum Number of Required EEBDs	623
	SECTION 4	Requirements for Vessels Under 500 Gross Tons	624
	1	General.....	624
	3	Fire Pumps	624
	3.1	Number of Pumps	624
	3.3	Capacity	624

5	Fixed Fire Extinguishing Systems.....	624
5.1	Fixed Systems	624
5.3	Portable Extinguishers.....	624
7	Carbon Dioxide Systems	624
7.1	Storage	624
9	Axe	625
11	Vessels Intended to Carry Oil in Bulk	625
11.1	Cargo Pump Rooms	625
11.3	Cargo Tank Protection.....	625
TABLE 1	Fire Pump Minimum Capacity for Vessels Less Than 500 Gross Tons.....	625

PART

4

CHAPTER 7 Fire Safety Systems

SECTION 1 General Provisions

1 Application

The provisions of Part 4, Chapter 7 apply to all self-propelled, ocean-going vessels. Sections 4-7-1 through 4-7-3 apply to vessels of 500 gross tons and above, while Section 4-7-4 applies to vessels under 500 gross tons.

Attention is directed to the appropriate governmental authority in each case, as there may be additional requirements, depending on the size, type and intended service of the vessels. Consideration will be given to fire-extinguishing systems that comply with the published requirements of the governmental authority of the country whose flag the vessel is entitled to fly as an alternative or addition to the requirements of this section.

Specific requirements for specialized vessels, such as oil carriers, ro-ro vessels, passenger vessels, etc., as provided in Part 5C are also to be complied with, as applicable.

The requirements in this section are in substantial agreement with SOLAS 1974, as amended, for cargo ships. Text shown in *italic* font is adapted directly from SOLAS, with changes only to tenses and references. The arrangements, fire safety systems and equipment as required by this Chapter are also to comply with the requirements of the International Code for Fire Safety Systems (FSS Code).

Alternative designs and arrangements (see Regulation II-2/17) deviating from these requirements may be specially considered, provided the Flag Administration approves the engineering analysis for evaluation of the design and arrangements and recognizes that they meet the fire safety objectives and the functional requirements. [Refer to the Guidelines on Alternative Design and Arrangements for Fire Safety (MSC/Circ. 1002)].

3 Basic Principles

The requirements of fire safety are based on the following basic principles:

- i) The provision of appropriate fire detection and extinguishing systems and equipment capable of extinguishing the types and scales of fire that are likely to occur onboard the vessel. These requirements are as specified in SOLAS and are provided in this section.
- ii) The proper design of fuel oil and other flammable fluid systems to assure the integrity of containment, to guard against the inadvertent escape of the flammable fluids, and to minimize the likelihood of ignition in the event of an escape or loss of containment. These requirements are as specified in Regulations II-2/4 of SOLAS and are provided in Sections 4-6-5 and 4-6-6.
- iii) The protection of crew accommodation spaces, by means of structural insulation, from spaces of high fire risks and from the spread of fire; and the protection of escape routes in the event of a fire outbreak. These requirements are as specified in SOLAS and are provided in Section 3-4-1.
- iv) The identification of fire risks of the cargoes carried or that related to the specific functions of the vessel, and the provision of effective means to both prevent and extinguish fires in the cargo and working spaces. These requirements are as specified in SOLAS and are provided in Part 5C for each vessel type.

5 Organization of Chapter 7

The Chapter contains two main sets of requirements:

- Section 4-7-2 describes the fire extinguishing fixtures and fire safety requirements of spaces of different fire risks onboard vessels; and
- Section 4-7-3 describes the requirements for each type of fire extinguishing system and equipment.
- Section 4-7-4 describes the requirements for vessels under 500 gross tons.

The organization of the chapter is illustrated in 4-7-1/Figure 1.

FIGURE 1
Organization of Chapter 7

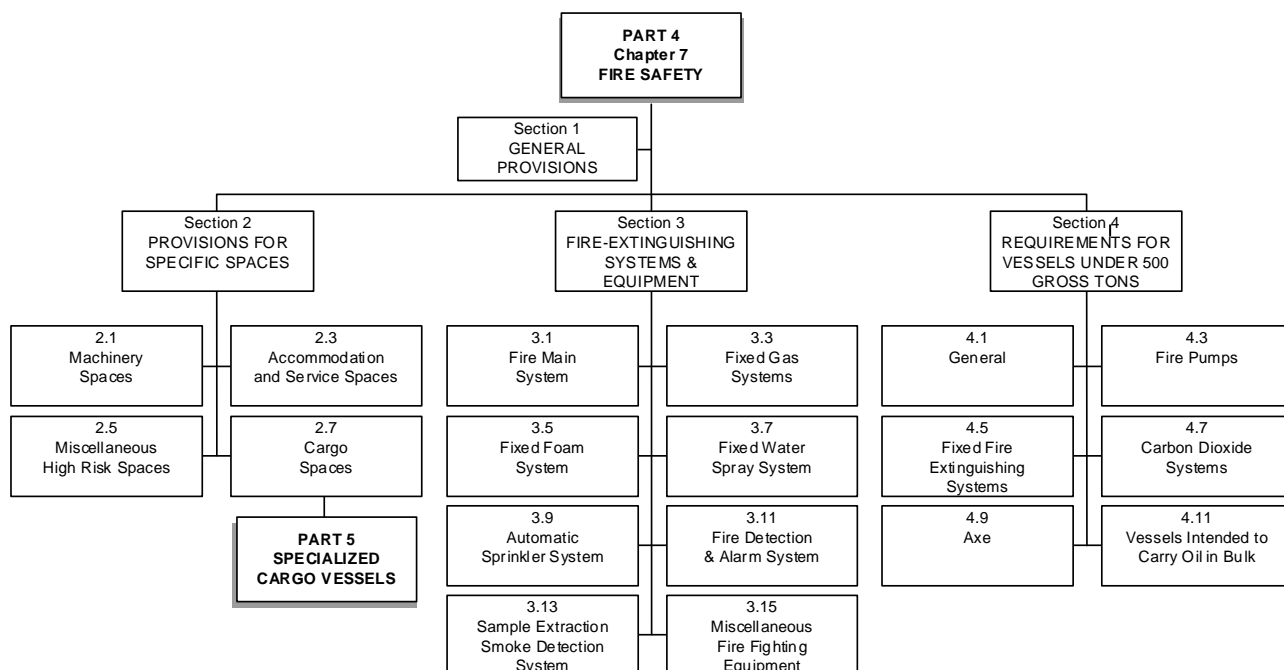

7 Plans and Data to be Submitted

Plans and specifications of the following fire fighting systems and equipment are to be submitted.

- Arrangement and details of fire main system
- Arrangement and details of portable fire extinguishing equipment
- Fixed fire-extinguishing systems (for example: CO₂, water sprinkler, foam, etc.)
- Fixed fire detection and alarm systems
- Other fire extinguishing arrangements
- Fire extinguishing appliances
- Control station for emergency closing of openings and stopping machinery
- Fireman's outfits
- Fire control plan (see 4-7-1/9)
- Arrangements of control stations indicated in the fire control plan

- Helicopter operations fire fighting system (where applicable)
- The most severe service condition for the operation of the emergency fire pump (e.g., lightest draft as shown in Trim and Stability Booklet, etc., refer to 4-7-3/1.5.3.)
- Calculations and pump data demonstrating that the emergency fire pump system can meet the operational requirements specified in 4-7-3/1.5.3 with the proposed pump location and piping arrangements (e.g., adequate suction lift, discharge pressure, capacity, etc.) at the most severe service condition

In general, piping system plans are to be diagrammatic and are to include the following information:

- Types, sizes, materials, construction standards, and pressure and temperature ratings of piping components other than pipes.
- Materials, outside diameter or nominal pipe size, and wall thickness or schedule of pipes.
- Design pressure and design temperature.
- Maximum pump pressures and/or relief valve settings.
- Flash point of flammable liquids, if below 60°C (140°F).
- Instrumentation (optional).
- Legend for symbols used.

9 Fire Control Plan

General arrangement plans are to be permanently exhibited for the guidance of the vessel's officers, showing clearly for each deck the control stations, the various fire sections enclosed by "A" class divisions, the sections enclosed by "B" class divisions together with particulars of the fire detection and fire alarm systems, the sprinkler installation, the fire extinguishing appliances, means of access to different compartments, decks, etc. and the ventilating system including particulars of the fan control positions, the position of dampers and identification numbers of the ventilating fans serving each section.

*Alternatively, the aforementioned details may be set out in a booklet, a copy of which is to be supplied to each officer, and one copy is to be available at all times onboard in an accessible position. Plans and booklets are to be kept up to date, any alterations thereto are to be recorded as soon as practicable. Description in such plans and booklets are to be in the language or languages required by the Administration. If the language is neither English nor French, a translation into one of those languages is to be included. A duplicate set of fire control plans or a booklet containing such plans are to be permanently stored in a prominently marked weathertight enclosure outside the deckhouse for the assistance of shore-side fire fighting personnel**.*

* Refer to Graphical symbols for shipboard fire control plan, adopted by IMO by resolution A.952(23).

** Refer to the Guidance concerning the location of the fire control plans for assistance of shoreside fire-fighting personnel (MSC/Cir.451).

11 Definitions

11.1 A, B or C Class Division

A division formed by bulkheads, decks, ceiling, lining and non-combustible materials capable of preventing the passage of smoke and flame when subject to a standard fire test for a specified duration as defined in SOLAS 1974, as amended, Regulation II-2/3.

11.3 Accommodation Spaces

Accommodation Spaces are those spaces used for public spaces, corridors, lavatories, cabins, offices, hospitals, cinemas, games and hobbies rooms, barber shops, pantries containing no cooking appliances and similar spaces.

11.5 Public Spaces

Public Spaces are those portions of the accommodation which are used for halls, dining rooms, lounges and similar permanently enclosed spaces.

11.7 Service Spaces

Service Spaces are those spaces used for galleys, pantries containing cooking appliances, lockers, mail and specie rooms, store-rooms, workshops other than those forming part of the machinery spaces, and similar spaces and trunks to such spaces.

11.9 Cargo Spaces

Cargo Spaces are all spaces used for cargo, cargo oil tanks, tanks for other liquid cargo and trunks to such spaces.

11.11 Ro-Ro Cargo Spaces

Ro-Ro Cargo Spaces are spaces not normally subdivided in any way and normally extending to either a substantial length or the entire length of the vessel in which motor vehicles with fuel in their tanks for their own propulsion and/or goods (packaged or in bulk, in or on rail or road cars, vehicles (including road or rail tankers), trailers, containers, pallets, demountable tanks or in or on similar stowage units or other receptacles) can be loaded and unloaded normally in a horizontal direction.

Open Ro-Ro Cargo Spaces are those ro-ro spaces that are either open at both ends, or have an opening at one end, and are provided with adequate natural ventilation effective over their entire length through permanent openings distributed in the side plating or deck-head or from above, having a total area of at least 10% of the total area of the space side.

Closed Ro-Ro Cargo Spaces are ro-ro spaces which are neither open ro-ro spaces nor weather decks (see 4-7-1/11.13).

11.13 Weather Deck

A Weather Deck is a deck which is completely exposed to the weather from above and from at least two sides.

11.15 Machinery Spaces of Category A

Machinery Spaces of Category A are those spaces and trunks to such spaces which contain either:

- i) internal combustion machinery used for main propulsion;
- ii) internal combustion machinery used for purposes other than main propulsion where such machinery has in the aggregate a total power output of not less than 375 kW (500 hp);
- iii) any oil-fired boiler or oil fuel unit, or any oil-fired equipment other than boiler, such as inert gas generator, incinerator, waste disposal units, etc.

11.17 Machinery Spaces

Machinery Spaces are all machinery spaces of category A and all other spaces containing propulsion machinery, boilers, oil fuel units, steam and internal combustion engines, generators and major electrical machinery, oil filling stations, refrigerating, stabilizing, ventilation and air conditioning machinery, and similar spaces, and trunks to such spaces.

11.19 Oil Fuel Unit

An Oil Fuel Unit is the equipment used for the preparation of oil fuel for delivery to an oil-fired boiler (including inert gas generators, incinerators, waste disposal units, etc.), or equipment used for the preparation for delivery of heated or non-heated oil to an internal combustion engine, and includes any oil pressure pumps, filters and heaters dealing with oil at a pressure of more than 1.8 bar (1.8 kgf/cm², 26 psi).

11.21 Control Stations

11.21.1 Control Stations

Control Stations are those spaces in which the vessel's radio or main navigating equipment or the emergency source of power is located or where the fire recording or fire control equipment is centralized. Spaces where the fire recording or fire control equipment is centralized are also considered to be a fire control station.

Spaces containing, for instance, the following battery sources are to be regarded as control stations, regardless of battery capacity:

- i) emergency batteries in separate battery room for power supply from black-out till start of emergency generator;*
- ii) emergency batteries in separate battery room as reserve source of energy to radiotelegraph installation;*
- iii) batteries for start of emergency generator;*
- iv) and, in general, all emergency batteries required in pursuance of 4-8-2/5.*

11.21.2 Central Control Station

Central control station is a control station in which the following control and indicator functions are centralized:

- i) fixed fire detection and fire alarm systems;*
- ii) automatic sprinkler, fire detection and fire alarm systems;*
- iii) fire door indicator panels;*
- iv) fire door closure;*
- v) watertight door indicator panels;*
- vi) watertight door closures;*
- vii) ventilation fans;*
- viii) general/fire alarms;*
- ix) communication systems including telephones; and*
- x) microphones to public address systems.*

11.23 Continuously Manned Central Control Station

A Continuously Manned Central Control Station is a central control station which is continuously manned by a responsible member of the crew.

11.25 Dangerous Goods

Dangerous Goods are those goods referred to in the International Maritime Dangerous Goods Code, IMDG Code, as defined in SOLAS regulation VII/1.1, (see also 4-7-2/Table 1).

13 Piping Systems

Piping systems in this Chapter are subject to the provisions of Part 4, Chapter 6, Section 1, Section 2 and Section 3 (referred to as Section 4-6-1, Section 4-6-2, and Section 4-6-3) for pipe materials, pipe design, fabrication and testing, and piping general installation requirements.

15 Additional Fixed Fire Extinguishing Systems

Where a fixed fire extinguishing system not required by Section 4-7-2 is installed, such system is to meet the applicable requirements of Section 4-7-3 and is to be submitted for approval.

PART

4

CHAPTER 7 Fire Safety Systems

SECTION 2 Provisions for Specific Spaces

1 Requirements for Machinery Spaces

In addition to the provisions of 4-7-3/1 for a fire main system, the following are to be complied with.

1.1 Spaces Containing Oil-fired Boilers or Oil Fuel Units

Requirements specified for oil-fired boilers are also applicable to oil-fired inert gas generators and oil-fired incinerators.

1.1.1 Fixed Fire Extinguishing Systems

Machinery spaces of category A containing oil-fired boilers or oil fuel units are to be provided with any one of the following fixed fire extinguishing systems:

- i) a fixed gas system complying with the provisions of 4-7-3/3;*
- ii) a fixed high expansion foam system complying with the provisions of 4-7-3/5.1; or*
- iii) a fixed pressure water-spraying system complying with the provisions of 4-7-3/7.*

In each case, if the engine and boiler rooms are not entirely separate, or if fuel oil can drain from the boiler room into the engine room, the combined engine and boiler rooms are to be considered as one compartment.

1.1.2 Portable Foam Applicator

There is to be in each boiler room and each oil fuel unit room, or at the entrance outside of the boiler room or the oil fuel unit room at least one set of portable foam applicator unit complying with the provisions of 4-7-3/15.3.

1.1.3 Portable Fire Extinguishers

There are to be at least two portable foam extinguishers or equivalent in each firing space in each boiler room and in each space in which a part of the oil fuel installation is situated. There is to be not less than one approved foam-type extinguisher of at least 135 liters (36 US gallon) capacity or equivalent in each boiler room. These extinguishers are to be provided with hoses on reels suitable for reaching any part of the boiler room. In case of domestic boilers of less than 175 kW, an approved foam-type extinguisher of at least 135 liters (36 US gallon) capacity is not required.

1.1.4 Dry Material

In each firing space, there is to be a receptacle containing at least 0.1 m³ (3.5 ft³) of sand, sawdust impregnated with soda, or other approved dry material, along with a suitable shovel for spreading the material. An approved portable extinguisher may be substituted as an alternative.

Number of Fixed Systems, Applicators and Extinguishers Required by 4-7-2/1

Systems, appliances & extinguishers → Category A machinery spaces ↓	Fixed fire-extinguishing system	Portable foam applicator ⁽¹⁾	Portable foam extinguishers	Add'l portable foam extinguishers	135 l foam extinguisher	45 l foam extinguishers ⁽²⁾	Sand boxes ⁽³⁾
<i>Boiler room containing:</i>							
Oil-fired boilers	1	1	2N	NA	1 ⁽⁴⁾	-	N
Oil-fired boilers and oil fuel units	1	1	2N + 2	NA	1 ⁽⁴⁾	-	N
<i>Engine room containing:</i>							
Oil fuel units only	1	1	2	NA	-	-	-
Internal combustion machinery	1	1	x		-	y	-
Internal combustion machinery and oil fuel units	1	1	x		-	y	-
<i>Combined engine/boiler room containing:</i>							
Internal combustion machinery, oil fired boilers and oil fuel units	1	1	(2N + 2) or x whichever is greater		1 ⁽⁴⁾	y ⁽⁵⁾	N
N = number of firing spaces (i.e., stations where the firing equipment is located) 2N = means that two extinguishers are to be located at each station containing the firing equipment x = sufficient number, minimum two in each space, so located that there is at least one portable fire extinguisher within 10 m walking distance from any point y = sufficient number to enable foam to be directed onto any part of the fuel and lubricating oil pressure systems, gearing and other fire hazards NA = not applicable							

Notes:

- 1 May be located outside of the entrance to the room.
- 2 May be arranged outside of the space concerned for smaller spaces on cargo vessels.
- 3 The amount of sand is to be at least 0.1 m³. For other approved dry materials, or substitution, refer to 4-7-2/1.1.4.
- 4 Not required for such spaces in cargo ships wherein all boilers contained therein are for domestic services and are less than 175 kW.
- 5 In case of machinery spaces containing both boilers and internal combustion engines, one of the foam fire-extinguishers of at least 45 liter capacity or equivalent, required by 4-7-2/1.3iii), may be omitted on the condition that the 135 liter extinguisher required by 4-7-2/1.1.3 can protect efficiently and readily the area that would be otherwise covered by the 45 liter extinguisher.
- 6 For the purpose of the statement in the table above, oil fired inert gas generators and oil fired incinerators are to be considered the same as oil fired boiler.

1.3 Spaces Containing Internal Combustion Machinery

Machinery spaces of category A containing internal combustion machinery are to be provided with:

- i) *One of the fixed fire extinguishing systems required by 4-7-2/1.1.1.*
- ii) *At least one set of portable foam applicator unit complying with the provisions of 4-7-3/15.3.*
- iii) *In each such space, approved foam type fire extinguishers, each of at least 45 liters (12 US gallon) capacity or equivalent, sufficient in number to enable foam or its equivalent to be directed on to any part of the fuel and lubricating oil pressure systems, gearing and other fire hazards. In addition, there are to be provided a sufficient number of portable foam extinguishers, or equivalent, which are to be so located that no point in the space is more than 10 m (33 ft) walking distance from an extinguisher and that there are at least two such extinguishers in each such space.*

1.5 Spaces Containing Steam Turbines or Enclosed Steam Engines

In spaces containing steam turbines or enclosed steam engines used either for main propulsion or for other purposes when such machinery has in the aggregate a total power output of not less than 375 kW (500 hp), there are to be provided:

- i) *Approved foam fire extinguishers each of at least 45 liter (12 gal) capacity or equivalent sufficient in number to enable foam or its equivalent to be directed on to any part of the pressure lubrication system, on to any part of the casings enclosing pressure lubricated parts of the turbines, engines or associated gearing, and any other fire hazards. However, such extinguishers are not required if protection by a fixed fire extinguishing system in compliance with 4-7-2/1.1.1 is provided.*
- ii) *A sufficient number of portable foam extinguishers or equivalent which are to be so located that no point in the space is more than 10 m (33 ft) walking distance from an extinguisher and that there are at least two such extinguishers in each such space, except that such extinguishers are not required in addition to any provided in compliance with 4-7-2/1.1.3.*
- iii) *One of the fire-extinguishing systems required by 4-7-2/1.1.1, where such spaces are periodically unattended.*

1.7 Fire Extinguishing Appliances in Other Machinery Spaces

Any machinery space which is not required to be fitted with the fire extinguishing provision of 4-7-2/1.1, 4-7-2/1.3 or 4-7-2/1.5, but in which fire hazards exist, is to be provided with a sufficient number of portable fire extinguishers or other means of fire extinction in, or adjacent to, that space.

1.9 Machinery Space Openings

1.9.1 General

In machinery space of category A, the number of skylights, doors, ventilators, openings in funnels to permit exhaust ventilation and other openings to machinery spaces are to be reduced to a minimum, consistent with the needs of ventilation and the proper and safe working of the vessel. In addition, the following requirements are also applicable. Other machinery spaces, where significant fire hazards exist, are also subject to the same requirements.

1.9.2 Skylights

Machinery space skylights are to be of steel and are not to contain glass panels. Suitable arrangements are to be made to permit the release of smoke in the event of fire from the space to be protected, subject to the provision of 4-7-2/1.9.1 above. The normal ventilation systems may be acceptable for this purpose.

1.9.3 Windows

Windows are not to be fitted in boundaries of machinery space. This does not preclude the use of glass in control rooms within the machinery spaces.

1.9.4 Access to Machinery Space

1.9.4(a) Escapes. Two means of escape are to be provided from each machinery space of category A. In particular, the following provisions are to be complied with:

- i) *Two sets of ladders as widely separated as possible leading to doors in the upper parts of the space similarly separated and from which access is provided to the open deck. One of these ladders is to be located within a protected enclosure that satisfies the requirements of SOLAS II-2/Reg. 9.2.3.3, category 4, from the lower part of the space it serves to a position outside the space. Self-closing fire doors of the same fire integrity are to be fitted in the enclosure. The ladder is to be fitted in such way that heat is not transferred into the enclosure through non-insulated fixing points. The enclosure is to have minimum internal dimensions of at least 800 mm × 800 mm (31.5 inch × 31.5 inch), and is to have emergency lighting provisions. Internal dimensions are to be interpreted as clear width, so that a passage having a diameter of 800 mm is available throughout the vertical enclosure, clear of ship's structure, insulation and equipment, if any. The ladder within the enclosure can be included in the internal dimensions of the enclosure. When protected enclosures include horizontal portions, their clear width shall not be less than 600 mm; or*

- ii) *One steel ladder leading to a door in the upper part of the space from which access is provided to the open deck and additionally, in the lower part of the space and in a position well separated from the ladder referred to, a steel door capable of being operated from each side and which provides access to a safe escape route from the lower part of the space to the open deck.*
- iii) *All inclined ladders/stairways fitted to comply with i), ii) above, with open treads in machinery spaces being part of or providing access to escape routes but not located within a protected enclosure shall be made of steel. Such ladders/stairways shall be fitted with steel shields attached to their undersides, such as to provide escaping personnel protection against heat and flame from beneath.*
- iv) *Two means of escape shall be provided from the machinery control room located within a machinery space of category A. At least one of these escape routes shall provide a continuous fire shelter to a safe position outside the machinery space.*
- v) *Two means of escape shall be provided from the main workshop within a machinery space of category A. At least one of these escape routes shall provide a continuous fire shelter to a safe position outside the machinery space.*

Inclined ladders/stairways in machinery spaces being part of, or providing access to, escape routes, but not located within a protected enclosure should not have an inclination greater than 60° and should not be less than 600 mm in clear width. Such requirement need not be applied to ladders/stairways not forming part of an escape route, only provided for access to equipment or components, or similar areas, from one of the main platforms or deck levels within such spaces.

In vessels of less than 1000 gross tonnage, one of the means of escape may be dispensed with, due regard being paid to the dimension and disposition of the upper part of the space. In addition, the means of escape from machinery spaces of category A need not comply with the requirement for an enclosed fire shelter listed in 4-7-2/1.9.4(a)i). In the steering gear space, a second means of escape is to be provided when the emergency steering position is located in that space unless there is direct access to the open deck.

1.9.4(b) Stairways and corridors used as means of escape. The width, number and continuity of escape routes are to be in accordance with the requirements in the Fire Safety Systems Code, Chapter 13.

1.9.4(c) Shaft tunnel. When access to any machinery space of category A is provided at a low level from an adjacent shaft tunnel, there is to be provided in the shaft tunnel, near the watertight door, a light steel fire-screen door operable from each side.

1.9.4(d) Access to machinery space other than category A. From machinery spaces other than those of category A, two escape routes are to be provided, except that a single escape route may be accepted for spaces that are entered only occasionally, and for spaces where the maximum travel distance to the door is 5 meters (16.4 feet) or less.

1.9.4(e) Lifts. Lifts are not to be considered as forming one of the required means of escape.

1.9.4(f) Emergency Escape Breathing Devices. On all vessels, within the machinery spaces, emergency escape breathing devices are to be situated at easily visible places ready for use, which can be reached quickly and easily at any time in the event of fire. The location of emergency escape breathing devices is to take into account the layout of the machinery space and the number of persons normally working in the space. (See MSC/Circ. 849) The emergency escape breathing devices are to comply with the provisions of 4-7-3/15.7. The number and locations of these devices are to be indicated in the fire control plan (see 4-7-1/9).

1.9.5 Machinery Space Ventilation

The main inlets and outlets of all ventilation systems are to be capable of being closed from outside the machinery space. The means of closing is to be easily accessible as well as prominently and permanently marked and is to indicate whether the shut-off is open or closed. All of the ventilation of machinery spaces is to be capable of being stopped from an easily accessible position outside the machinery space. This position is not to be readily cut off in the event of a fire in the machinery space. Controls provided for power ventilation serving machinery spaces are to be grouped so as to be operable from two positions, one of which is to be outside such spaces. The means provided for stopping the power ventilation of the machinery spaces is to be entirely separated from the means provided for stopping ventilation of other spaces.

1.9.6 Release of Smoke from Machinery Space

Suitable arrangements are to be made to permit the release of smoke, in the event of fire, from the machinery space of Category A. The normal ventilation may be acceptable for this purpose. The means of control is to be provided for permitting the release of smoke and such control is to be located outside the space concerned so that they will not be rendered inaccessible in the event of fire in the space they serve. See also 4-8-4/21.17.1

1.9.7 Closing of Openings and Emergency Shutdowns

Means of control, located outside the machinery space where they will not be cut off in the event of fire in the machinery space concerned, are to be provided for:

- i) opening and closure of skylights, closure of openings in funnels which normally allow exhaust ventilation, and closure of ventilator dampers (Emergency generator room openings for intake of combustion air and cooling air need not be fitted with means of closure for fire integrity purposes unless a fixed fire fighting system for the emergency generator space is provided.). See also 4-7-2/1.9.8;*
- ii) closing power-operated doors or actuating release mechanism on doors other than power-operated watertight doors;*
- iii) stopping ventilating fans;*
- iv) stopping forced and induced draught fans, oil fuel transfer pumps, oil fuel unit pumps, lubricating oil service pumps, thermal oil circulating pumps and oil separators (purifiers) and other similar fuel pumps (see 4-7-2/1.11.1), including stopping of fired equipment such as incinerator, this need not apply to oily water separators. Controls required by this paragraph are to be also provided from the compartment itself; and*
- v) closing of valves at fuel oil tanks and lubricating oil tanks, incinerator's waste oil service tank. (see 4-7-2/1.11.1).*

For a pneumatically operated system, the air supply may be from a source located within the same space as the closing devices (dampers), provided that a dedicated air receiver is located outside of the space. Sufficient air capacity to close all of the closing devices for engine room openings at least twice is to be provided.

1.9.8 Ventilation of Emergency Generator Rooms

Ventilation openings of emergency generator rooms provided for the admission of combustion air to engines and the removal of heat are usually fitted with louvers which can be closed when fire breaks out in the room. The louvers may be hand-operated or power-operated. Alternatively, the louvers may be of fixed type with a closing door which may be hand-operated or automatic.

The following requirements apply to ventilation louvers for emergency generator rooms and to closing appliances where fitted to ventilators serving emergency generator rooms:

- i) Ventilation louvers and closing appliances may either be hand-operated or power-operated (hydraulic/pneumatic/electric) and are to be operable under a fire condition.
- ii) Hand-operated ventilation louvers and closing appliances are to be kept open during normal operation of the vessel. Corresponding instruction plates are to be provided at the location where hand-operation is provided.
- iii) Power-operated ventilation louvers and closing appliances are to be of a fail-to-open type. Closed ventilation louvers and closing appliances are acceptable during normal operation of the vessel. Power-operated ventilation louvers and closing appliances are to open automatically whenever the emergency generator is starting/in operation.
- iv) It is to be possible to close ventilation openings by a manual operation from a clearly marked safe position outside the space where the closing operation can be easily confirmed. The louver status (open/closed) is to be indicated at this position. Such closing is not to be possible from any other remote position.

1.11 Fire Precautions for Fuel Oil, Lubricating Oil and Other Flammable Oils

1.11.1 Fire Precautions

References are to be made to the following provisions for prevention of fire that may arise due to the storage and use of flammable liquids:

- 4-6-4/13 and 4-6-4/15: for the storage, distribution and utilization of fuel oil and lubricating oil;
- 4-6-5/3 and 4-6-5/5: for fuel oil and lubricating oil systems of internal combustion engine installations;
- 4-6-6/7: for boiler fuel oil installations;
- 4-6-6/9: for lubricating oil systems of steam turbine and gear installations;
- 4-6-7/3: for hydraulic oil systems.

1.11.2 Fixed Local Application Fire-fighting Systems

For cargo vessels of 2000 gross tonnage and above, the machinery spaces of category A above 500 m³ (17,657 ft³) in volume, in addition to the fixed fire-extinguishing system required in 4-7-2/1.1.1 or 4-7-2/1.3 or 4-7-2/1.5, are to be protected by an approved type of fixed water-based or equivalent local application fire-fighting system complying with the provision of the IMO Guidelines for the Approval of Fixed Water-based Local Application Fire-fighting System for Use in Category A Machinery Spaces, MSC/Circ. 1387. In the case of periodically unattended machinery spaces, the fire fighting system is to have both automatic and manual release capabilities. In the case of continuously manned machinery spaces, the fire-fighting system is only required to have a manual release capability. The fixed local fire-fighting systems are to protect areas such as the following without the necessity of engine shutdown, personnel evacuation, or sealing the spaces:

- i) *the fire hazard portion of internal combustion machinery;*
- ii) *boiler front;*
- iii) *the fire hazard portions of incinerators; and*
- iv) *purifiers for heated fuel oil, see 4-6-4/13.9.2*

Activation of any local application system shall give a visual and distinct audible alarm in the protected space and at continuously manned stations. The alarm is to indicate the specific system activated. The system alarm requirements described within this paragraph are in addition to, and not a substitute for, the detection and fire alarm system required in elsewhere in Section 4-7-2 and Section 4-7-3.

A bridge alarm is to be provided with a visual notification when the system has been deactivated or placed in manual mode.

The pumps for fixed local application fire fighting systems are to be certified in accordance with 4-6-1/7.3.1i).

1.13 Propulsion Machinery Spaces Intended for Centralized or Unattended Operation

1.13.1 Fire Detection and Alarm Systems

Where a vessel's propulsion machinery is intended for centralized or *periodically unattended operation* (**ACC**, **ACCU** or **ABCU** notation; see Part 4, Chapter 9), a *fixed fire detection and alarm system* complying with 4-7-3/11, and as specified below, *is to be provided in the propulsion machinery space*.

Also, a fixed fire detection system is to be installed in machinery space where:

- i) *the installation of automatic and remote control system and equipment has been approved in lieu of continuous manning of the space, and;*
- ii) *the main propulsion and associated machinery including sources of the main sources of electrical power are provided with various degrees of automatic or remote control and are under continuous supervision from a control room.*
- iii) *Emergency Generator Spaces.* Where the emergency diesel generator space has an engine that is not less than 375 kW (500 hp), it is to be treated as a category A machinery space in accordance with 4-7-1/11.15, and as a control station in accordance with 4-7-1/11.21.
 - a) For installations with diesel engine of not less than 375 kW (500 hp), the space is to be provided with a fire detection system complying with 4-7-3/11.3.4(a)ii (i.e., the fire detection loop serving the EDG space cannot be combined with that of another Category A machinery space or another control station or a service space or an accommodation space). However, connection with the section of a machinery space other than Category A may be considered provided all other requirements of 4-7-3/11, as applicable, are met.
 - b) For installations with diesel engine with a power rating below 375 kW (500 hp), the space is considered a control station and the fire detectors may be on the same loop as the accommodation and/or service spaces provided all other requirements of 4-7-3/11, as applicable, are satisfied.

1.13.1(a) Detectors. This fire detection system is to be so designed and the detectors so positioned as to detect rapidly the onset of fire in any part of the space and under normal conditions of operation of the machinery and variation of ventilation as required by the possible range of ambient temperatures. Except in spaces of restricted height and where their use is specially appropriate, detection systems using only thermal detectors are not permitted.

Additionally, where fire detectors are provided with means to adjust their sensitivity, the arrangements are to be such that the set point can be fixed and readily identified. Such arrangements are to comply with the following:

- i) A permanent means clearly identifying the set point of each adjustable detector is to be provided. This may be accomplished by:
 - The placement of a permanent marking or etching directly on the detector which identifies the set point,
 - For those devices that are provided with a calibrated scale, a permanent indication or notation recorded directly on the detector which identifies the set point,
 - Indication in the control panel of the set level of each such detector, or
 - Other acceptable means (e.g., log book record, etc.); and
- ii) Means are to be provided to fix or otherwise secure the sensitivity settings of the detectors in a manner that ensures that the setting(s) will not be inadvertently or accidentally changed due to vibration, physical contact or changes in environmental conditions.

1.13.1(b) Alarms. The detection system is to initiate audible and visual alarms distinct in both respects from the alarms of any other system not indicating fire, in sufficient places to ensure that the alarms are heard and observed on the navigating bridge and by a responsible engineer officer. When the navigating bridge is unmanned, the alarm is to sound in a place where a responsible member of the crew is on duty. See also 4-9-5/15.5.1 and 4-9-6/21.5 for vessels assigned with **ACC**, **ACCU** and **ABCU**, respectively.

1.13.2 Fire Main System

The fire main system is to comply with the additional provisions of 4-7-3/1.5.5.

1.13.3 Fire Fighting Station

Vessels intended to be operated with an unattended propulsion machinery space are to be fitted with a fire fighting station complying with the provisions of 4-9-6/21.1.

3 Requirements for Accommodation and Service Spaces, and Control Stations

In addition to the provisions of 4-7-3/1 for a fire main system, the following are to be complied with.

3.1 Methods of Structural Fire Protection

One of the following methods of protection is to be adopted in accommodation and service spaces, and control stations:

3.1.1 Method I C

Method I C involves the construction of all internal divisional bulkheads of non-combustible “B” or “C” class divisions, generally without the installation of an automatic sprinkler, fire detection and fire alarm system in the accommodation and service spaces, except as required by 4-7-2/3.3.1.

3.1.2 Method II C

Method II C involves the fitting of an automatic sprinkler, fire detection and fire alarm system, as required by 4-7-2/3.3.2, for the detection and extinction of fire in all spaces in which fire might be expected to originate, generally with no restriction on the type of internal divisional bulkheading.

For the carriage of flammable liquids as identified in IMO A.673(16), ABS may permit use of a method other than IC as defined in 4-7- 2/3.1.1 above, where considered appropriate.

3.1.3 Method III C

Method III C involves the fitting of a fixed fire detection and fire alarm system, as required by 4-7-2/3.3.3, in all spaces in which a fire might be expected to originate, generally with no restriction on the type of internal divisional bulkheads, except that in no case must the area of any accommodation space or spaces bounded by an “A” or “B” class division exceed 50 m² (545 ft²). Consideration may be given to increasing this area for public spaces.

For the carriage of flammable liquids as identified in IMO A.673(16), ABS may permit use of a method other than IC as defined in 4-7- 2/3.1.1 above, where considered appropriate.

3.3 Fixed Fire Detection and Fire Alarm Systems; Automatic Sprinkler, Fire Detection and Fire Alarm Systems

Accommodation and service spaces and control stations of cargo vessels are to be protected by a fixed fire detection and fire alarm and/or an automatic sprinkler, fire detection and fire alarm system, as follows, depending on a protection method adopted in accordance with 4-7-2/3.1.

3.3.1 Requirements for Method I C

In vessels in which Method I C is adopted, a fixed fire detection and fire alarm system of an approved type complying with the requirements of 4-7-3/11 is to be installed and arranged as to provide smoke detection in all corridors, stairways and escape routes within accommodation spaces.

3.3.2 Requirements for Method II C

In vessels in which Method II C is adopted, an automatic sprinkler, fire detection and fire alarm system of an approved type complying with the relevant requirements of 4-7-3/9 is to be installed and arranged as to protect accommodation spaces, galleys and other service spaces, except spaces which afford no substantial fire risk, such as void spaces, sanitary spaces, etc. In addition, a fixed fire detection and fire alarm system of an approved type complying with the requirements of 4-7-3/11 is to be so installed and arranged as to provide smoke detection in all corridors, stairways and escape routes within accommodation spaces.

3.3.3 Requirements for Method III C

In vessels in which Method III C is adopted, a fixed fire detection and fire alarm system of an approved type complying with the requirements of 4-7-3/11 is to be so installed and arranged as to detect the presence of fire in all accommodation spaces and service spaces, providing smoke detection in corridors, stairways and escape routes within accommodations spaces, except spaces which afford no substantial fire risk such as void spaces, sanitary spaces, etc. In addition, a fixed fire detection and fire alarm system is to be so installed and arranged as to provide smoke detection in all corridors, stairways and escapes routes within accommodation spaces

3.4 Locations Requiring Manually Operated Call Points

Manually operated call points, see 4-7-3/11 for the fixed fire detection and fire alarm, are to be installed throughout the accommodation spaces, service spaces and control stations. One manually operated call point is to be located at each exit. Manually operated call points are to be readily accessible in the corridors of each deck such that no part of the corridor is more than 20 m (66 ft) from a manually operated call point.

The statement “Manually operated call points are to be installed throughout the accommodation spaces, service spaces and control stations” above, does not require the fitting of a manually operated call point in an individual space within the accommodation spaces, service spaces and control stations. However, a manually operated call point is to be located at each exit (inside or outside) to the open deck from the corridor such that no part of the corridor is more than 20 m (66 ft) from a manually operated call point. Service spaces and control stations which have only one access, leading directly to the open deck, are to have a manually operated call point not more than 20 m (66 ft) (measured along the access route using the deck, stairs and/or corridors) from the exit. A manually operated call point is not required to be installed for spaces having little or no fire risk, such as voids and carbon dioxide rooms, nor at each exit from the navigation bridge, in cases where the control panel is located in the navigation bridge.

3.5 Portable Extinguishers

Accommodation spaces (see 4-7-1/11.3), service spaces (see 4-7-1/11.7) and control stations (see 4-7-1/11.21) are to be provided with portable fire extinguishers of appropriate types (see 4-7-3/Table 4 and 4-7-3/Table 5). One of the portable fire extinguishers intended for use in any space is to be stowed near the entrance to that space. Corridors are to be provided with portable extinguishers at not more than 45 m (150 ft) apart. Vessels of 1,000 gross tonnage and upwards are to carry at least five portable fire extinguishers.

3.7 Ventilation Systems

3.7.1 Ventilation Ducts

Ventilation ducts are to be constructed and installed in accordance with Section 3-4-1 and Reg. II-2/9.7 of SOLAS.

3.7.2 Main Inlets and Outlets

The main inlets and outlets of all ventilation systems are to be capable of being closed from outside the spaces being ventilated. The means of closing is to be easily accessible as well as prominently and permanently marked and is to indicate whether the shut-off is open or closed.

3.7.3 Stopping of Power Ventilation

Power ventilation of accommodation spaces, service spaces and control stations are to be capable of being stopped from an easily accessible position outside the space being served. This position is not to be readily cut off in the event of a fire in spaces served. The means provided for stopping the power ventilation of the machinery spaces is to be entirely separate from the means provided for stopping ventilation for other spaces. See 4-8-2/11.9.1(d) for emergency shutdown.

3.7.4 Galley Range Exhaust Ducts

Where galley range exhaust ducts pass through accommodation spaces or spaces containing combustible materials, the exhaust duct is to be constructed of “A” class division. Each exhaust duct is to be fitted with:

- i) a grease trap readily removable for cleaning;
- ii) a fire damper located in the lower end of the duct and, in addition, a fire damper in the upper end of the duct;
- iii) arrangements, operable from within the galley, for shutting off the exhaust fan; and
- iv) fixed means of extinguishing a fire within the duct.

3.9 Requirements for Gaseous Fuel for Domestic Purposes

Gaseous fuel systems used for domestic purpose are to be submitted for approval. Storage of gas bottles is to be located on the open deck or in a well ventilated space which opens only to the open deck.

5 Requirements for Miscellaneous High-risk Spaces

In addition to the provisions of 4-7-3/1 for a fire main system, the following are to be complied with.

5.1 Paint and Flammable Liquid Lockers

Paint and flammable liquid lockers or any similar service spaces used for the storage of flammable liquids (such as solvents, adhesives, lubricants etc.) are to be protected by a fire extinguishing arrangement enabling the crew to extinguish a fire without entering the space. Unless required or permitted otherwise by the flag Administration, one of the following systems is to be provided:

5.1.1 Lockers of 4 m² (43 ft²) or more floor area and lockers with access to accommodation spaces

Paint lockers and flammable liquid lockers of floor area 4 m² (43 ft²) or more and also such lockers of any floor area with access to accommodation spaces are to be provided with one of the fixed fire extinguishing systems specified below:

- i) CO₂ system designed for 40% of the gross volume of the space.
- ii) Dry powder system designed for at least 0.5 kg/m³ (0.03 lb/ft³).
- iii) Water spraying system designed for 5 liters/m²/minute (0.12 gpm/ft²). The water spraying system may be connected to the vessel's fire main system, in which case the fire pump capacity is to be sufficient for simultaneous operation of the fire main system, as required in 4-7-3/1.7, and the water spray system. Precautions are to be taken to prevent the nozzles from becoming clogged by impurities in the water or corrosion of piping, nozzles, valves and pump.
- iv) Systems or arrangements other than those mentioned above may be considered, provided they are not less effective.

5.1.2 Lockers of less than 4 m² (43 ft²) floor area having no access to accommodation spaces

For paint lockers and flammable liquid lockers of floor area less than 4 m² (43 ft²) having no access to accommodation spaces, portable fire extinguisher(s) sized in accordance with 4-7-2/5.1.1i) and which can be discharged through a port in the boundary of the lockers may be accepted. The required portable fire extinguishers are to be stowed adjacent to the port. Alternatively, a port or hose connection may be provided for this purpose to facilitate the use of water from the fire main.

5.3 Helicopter Facilities

5.3.1 Application

For each helicopter deck onboard a vessel designated for helicopter operations, a fire fighting system and equipment complying with 4-7-2/5.3.2 and 4-7-2/5.3.3, as applicable, are to be provided.

A helicopter deck (helideck) is a purpose-built helicopter landing area on a vessel including all structure, fire fighting appliances and other equipment necessary for the safe operation of helicopters. A helicopter facility is a helideck including any refueling and hangar facility.

5.3.2 Provisions for Helicopter Deck

In close proximity to the helideck, the following fire-fighting appliances shall be provided and stored near the means of access to that helideck.

5.3.2(a) *Hoses and nozzles. At least two combination solid stream and water spray nozzles and hoses sufficient in length to reach any part of the helicopter deck are to be provided.*

5.3.2(b) *Dry powder extinguishers. The helicopter deck is to be protected by at least two dry powder extinguishers of a total capacity of not less than 45 kg (100 lb).*

5.3.2(c) *Carbon dioxide extinguishers. The helicopter deck is to be protected by CO₂ extinguishers of a total capacity of not less than 18 kg (40 lb) or equivalent, one of these extinguishers being equipped so as to enable it to reach the engine area of any helicopter using the helicopter deck. The CO₂ extinguishers are to be located so that the equipment would not be vulnerable to the same damage as the dry powder extinguisher required by 4-7-2/5.3.2(b).*

5.3.2(d) *Fixed foam system. A suitable fixed foam fire extinguishing system, consisting of monitors or hose streams or both, is to be installed to protect the helicopter landing area in all weather conditions in which helicopters can operate. The system is to be capable of delivering foam solution at a discharge rate in accordance with the following table for at least five minutes. The operation of the foam system is not to interfere with the simultaneous operation of the fire main.*

Category	Helicopter overall length, L_H	Discharge rate	
		Liters/min	gpm
H1	$L_H < 15 \text{ m (49 ft)}$	250	66
H2	$15 \text{ m (49 ft)} \leq L_H < 24 \text{ m (79 ft)}$	500	132
H3	$24 \text{ m (79 ft)} \leq L_H < 35 \text{ m (115 ft)}$	800	211

The foam agent is to be suitable for use with salt water and conform to performance standards not inferior to those acceptable to the IMO. Refer to the International Civil Aviation Organization Airport Services Manual, part 1, Rescue and Fire Fighting, chapter 8, Extinguishing Agent Characteristics, paragraph 8.1.5, Foam Specifications table 8-1, level 'B'.

5.3.2(e) *Firefighter's outfits. In addition to the firefighter's outfits required in 4-7-3/15.5.2, two additional sets of firefighter's outfits.*

5.3.2(f) *Other equipment. The following equipment is to be provided near the helicopter deck and is to be stored in a manner that provides for immediate use and protection from the elements:*

- adjustable wrench
- fire resistant blanket
- bolt cutters with arm length of 60 cm (24 in.) or more
- grab hook or salving hook
- heavy duty hack saw, complete with six spare blades
- ladder
- lifeline of 5 mm (³/₁₆ in.) diameter × 15 m (50 ft) length
- side cutting pliers
- set of assorted screwdrivers
- harness knife, complete with sheath

5.3.3 Provisions for Enclosed Helicopter Facilities

Hangars, refueling and maintenance facilities are to be treated as machinery space of category A with regard to structural fire protection, fixed fire-extinguishing system and fire detection system requirements. See 4-7-2/1.

5.3.4 Operation Manual

Each helicopter facility is to have an operation manual, including a description and a checklist of safety precautions, procedures and equipment requirements. This manual may be part of the vessel's emergency response procedures.

5.3.5 Aluminum Helicopter Decks with Equivalency of Fire Integrity to Steel Helideck

Where aluminum helideck is located 1m (3.25 ft) or less above superstructure or deckhouses and comply with the requirements of 3-2-11/11.5.1 and 3-2-11/11.5.1, this arrangement is considered to have the equivalent fire integrity to steel helideck, provided that the underside of aluminum helicopter deck is protected by a water spray system with ability to maintain rate of not less than 10.2 liters/min/m² (0.25 gpm/ft²).

Alternatively, the use of intumescent coatings may be acceptable in protecting the underside of aluminum helicopter decks structure, provided the selection of the fire rating of the coating is based on the results from a risk analysis and/or fire load calculation which is to be submitted for ABS for approval.

5.5 Deep-fat Cooking Equipment

Deep-fat cooking equipment is to be fitted with the following:

- i) an automatic or manual extinguishing system tested to an international standard acceptable to ABS (see ISO 15371:2009 on Fire-extinguishing systems for protection of galley deep-fat cooking equipment, or UL 300 Standard for Testing of Fire Extinguishing Systems for Protection of Restaurant Cooking Areas);
- ii) a primary and backup thermostat with an alarm to alert the operator in the event of failure of either thermostat;
- iii) arrangements for automatically shutting off of the electrical power upon activation of the extinguishing system;
- iv) an alarm for indicating operation of the extinguishing system in the galley where the equipment is installed; and
- v) controls for manual operation of the extinguishing system which are clearly labeled for ready use by the crew.

5.7 Furnaces of Thermal Oil Heaters

See 4-4-1/13.3.6 for fixed fire extinguishing requirements.

5.9 Rotating Machines for Propulsion

Refer to 4-8-5/5.17.5(b) for fire extinguishing system.

5.11 Spaces Containing Equipment with Oil Filled Capacitors

Spaces containing equipment with flammable oil filled capacitors are to be provided with any one of the following fixed fire extinguishing systems:

- i) A gas system complying with the provisions of 4-7-3/3; or
- ii) Other approved fire extinguishing system suitable for the equipment voltage hazard.

7 Requirements for Cargo Spaces

In addition to the provisions of 4-7-3/1 for a fire main system, the following are to be complied with.

7.1 Dry Cargo Spaces

7.1.1 Fixed Gas Fire Extinguishing System

Except for ro-ro and vehicle spaces, cargo spaces on cargo vessels of 2,000 gross tonnage and upwards are to be protected by a fixed carbon dioxide gas fire-extinguishing system complying with the provisions of 4-7-3/3 or an inert gas fire extinguishing system complying with the inert gas system provisions of 5C-1-7/25, or by a fire-extinguishing system which gives equivalent protection.

7.1.2 Vessels Carrying Dangerous Goods

A vessel engaged in the carriage of dangerous goods in any cargo space is to be provided with a fixed carbon dioxide or inert gas fire extinguishing system complying with the provisions of 4-7-3/3 and 5C-1-7/25 respectively, or with a fire extinguishing system which gives equivalent protection for the cargoes carried. Such vessels are to comply also with the provisions of 4-7-2/7.3.

7.1.3 Vessels Carrying Low Fire Risk Cargoes

ABS may exempt from the requirements of 4-7-2/7.1.1 and 4-7-2/7.1.2 cargo spaces of any cargo vessel if constructed, and solely intended, for the carriage of ore, coal, grain, unseasoned timber, noncombustible cargoes or cargoes which, constitute a low fire risk Such exemptions may be granted only if the vessel is fitted with steel hatch covers and effective means of closing all ventilators and other openings leading to the cargo spaces. When such exemptions are granted, ABS is to issue an Exemption Certificate, irrespective of the date of construction of the vessel concerned, in accordance with SOLAS regulation I/12(a)(vii), and is to ensure that the list of cargoes the ship is permitted to carry is attached to the Exemption Certificate.*

** Refer to the International Maritime Solid Bulk Cargoes (IMSBC) Code, adopted by the IMO by resolution MSC.268(85), as amended, appendix 1, entry for coal, and to the Lists of solid bulk cargoes for which a fixed gas fire-extinguishing system may be exempted or for which a fixed gas fire-extinguishing system is ineffective (MSC.1/Circ.1395).*

7.3 Dry Cargo Spaces Intended to Carry Dangerous Goods

In addition to complying with 4-7-2/7.1.2, the requirements specified in 4-7-2/7.3.1 through 4-7-2/7.3.10 are applicable to vessels and cargo spaces intended for the carriage of dangerous goods, (see 4-7-2/Table 1), except when carrying dangerous goods in limited quantities (see 4-7-2/Table 2 below) as referred in Part 3 Chapter 4 of the IMO's *International Maritime Dangerous Goods Code (IMDG Code)*.

Specialized carriers, such as container carriers, ro-ro vessels and vehicle carriers, and bulk carriers intended to carry dangerous goods are to comply with the applicable requirements of 4-7-2/7.3.1 through 4-7-2/7.3.10, as indicated in Part 5C for each of these specific vessel types. For general cargo vessels, see 4-7-2/7.5.

7.3.1 Water Supplies

7.3.1(a) Availability of water. Arrangements are to be made to ensure immediate availability of a supply of water from the fire main at the required pressure either by permanent pressurization or by suitably placed remote starting arrangements for the fire pumps. The total required capacity of fire water supply is to satisfy 4-7-2/7.3.1(b) and 4-7-2/7.3.1(c), simultaneously calculated for the largest designated cargo space.

7.3.1(b) Quantity of water. The quantity of water delivered is to be capable of supplying four nozzles of a size and at pressures as specified in 4-7-3/1.7 and 4-7-3/1.15, capable of being trained on any part of the cargo space when empty. This amount of water may be applied by equivalent means, the arrangements of which are to be submitted to ABS for approval. The capacity requirement is to be met by the total capacity of the main fire pumps, not including the capacity of the emergency fire pump.

7.3.1(c) *Under deck cargo space cooling.* Means are to be provided for effectively cooling the designated under deck cargo space by at least 5 liters/min/m² (0.12 gal/min/ft²) of the horizontal area of cargo spaces, either by a fixed arrangement of spraying nozzles, or flooding the cargo space with water.

Hoses may be used for this purpose in small cargo spaces and in small areas of larger cargo spaces. However, the drainage and pumping arrangements are to be such as to prevent the build-up of free surfaces. The drainage system is to be sized to remove no less than 125% of the combined capacity of both the water spraying system pumps and the required number of nozzles. The drainage system valves are to be operable from outside of the protected space at a position in the vicinity of the extinguishing system controls. Bilge wells are to be of sufficient holding capacity and are to be arranged at the side shell of the vessel at a distance from each other of not more than 40 m (131 ft) in each watertight compartment. If this is not possible, the adverse effect upon stability of the added weight and free surface of water are to be taken into account for the approval of the stability information. Reference is to be made to IMO Resolution A.123(V) Recommendations on Fixed Fire Extinguishing Systems for Special Category Spaces.

7.3.1(d) *Alternative to cooling by water.* Provision to flood a designated under deck cargo space with suitable specified media may be substituted for the requirements in 4-7-2/7.3.1(c). The total required capacity of the water supply is to satisfy 4-7-2/7.3.1(b) and 4-7-2/7.3.1(c), if applicable, simultaneously calculated for the largest designated cargo space. The capacity requirements of 4-7-2/7.3.1(b) are to be met by the total capacity of the main fire pump(s), not including capacity of the emergency pump, if fitted. If a drencher system is used to satisfy 4-7-2/7.3.1(c), the drencher pump is also to be taken into account in this total capacity calculation.

7.3.2 Sources of Ignition

Electrical equipment and wiring are not to be fitted in enclosed cargo spaces or vehicle spaces unless it is essential for operational purposes. However, if electrical equipment is fitted in such spaces, it is to be of a certified safe type for use in the dangerous environments to which it may be exposed unless it is possible to completely isolate the electrical system (by removal of links in the system, other than fuses). Cable penetrations of the decks and bulkheads are to be sealed against the passage of gas or vapor. Through runs of cables and cables within the cargo spaces are to be protected against damage from impact. Any other equipment which may constitute a source of ignition of flammable vapor is not to be permitted.

7.3.3 Detection System

Ro-ro spaces are to be fitted with a fixed fire detection and fire alarm system of an approved type complying with 4-7-3/11. All other types of cargo spaces are to be fitted with either a fixed fire detection and fire alarm system of an approved type complying with 4-7-3/11 or a sample extraction smoke detection system of an approved type complying with 4-7-3/13. If a sample extraction smoke detection system is fitted, particular attention is to be made to 4-7-3/13.1.3 in order to prevent the leakage of toxic fumes into the occupied areas.

7.3.4 Ventilation

7.3.4(a) *Number of air changes.* Adequate power ventilation is to be provided in enclosed cargo spaces. The arrangement is to be such as to provide for at least six air changes per hour in the cargo space based on an empty cargo space and for removal of vapors from the upper or lower parts of the cargo space, as appropriate. If adjacent spaces are not separated from cargo spaces by gastight bulkheads or decks, ventilation requirements for such spaces apply as for the cargo space itself.

7.3.4(b) *Fans.* The fans are to be of non-sparking type (see 4-8-3/11) such as to avoid the possibility of ignition of flammable gas air mixtures. Suitable wire mesh guards of a maximum of 13 mm (0.5 in.) square mesh is to be fitted over inlet and outlet ventilation openings.

7.3.4(c) *Stopping of power ventilation.* Power ventilation of cargo spaces is to be capable of being stopped from an easily accessible position outside the spaces served. This position is not to be readily cut off in the event of a fire in the spaces served. See 4-8-2/11.9.1(b) for emergency shutdown and 4-7-2/3.7.3 for power ventilation stopping arrangements.

7.3.4(d) *Natural ventilation.* Natural ventilation is to be provided in enclosed cargo spaces intended for the carriage of solid dangerous goods in bulk, where there is no provision for mechanical ventilation.

7.3.5 Bilge Pumping

7.3.5(a) *General.* Where it is intended to carry flammable or toxic liquids in enclosed cargo spaces the bilge pumping system is to be designed to ensure against inadvertent pumping of such liquids through machinery space piping or pumps. Where large quantities of such liquids are carried, consideration is to be given to the provision of additional means of draining these cargo spaces. See 4-6-4/5.5.9 for bilge systems serving cargo spaces intended to carry dangerous goods.

7.3.5(b) *System capacity.* If the bilge drainage system is additional to the system served by pumps in the machinery space, the capacity of the system is to be not less than 10 m³/h (44 gpm) per cargo space served. If the additional system is common, the capacity need not to exceed 25 m³/h (110 gpm). The additional bilge system need not be arranged with redundancy.

7.3.5(c) *System isolation.* Whenever flammable or toxic liquids are carried, the bilge line into the machinery space is to be isolated either by fitting a blank flange or by a closed lockable valve.

7.3.5(d) *Ventilation.* Enclosed spaces outside machinery spaces containing bilge pumps serving cargo spaces intended for carriage of flammable or toxic liquid are to be fitted with a separate ventilation system giving at least 6 air changes per hour. If the space has access from another enclosed space, the door is to be self-closing.

7.3.5(e) *Bilge drainage.* If bilge drainage of cargo spaces is arranged by gravity drainage, the drainage is to be either led directly overboard or to a closed drain tank located outside the machinery spaces. The tank is to be provided with a vent pipe to a safe location on the open deck. Drainage from a cargo space into bilge wells in a lower space is only permitted if that space satisfies the same requirements as the cargo space above.

7.3.6 Personnel Protection

7.3.6(a) *Protective clothing.* Four sets of full protective clothing, resistant to chemical attack, are to be provided in addition to the firefighter's outfits required by 4-7-3/15.5.2. The protective clothing is to cover all skin, so that no part of the body is unprotected.

7.3.6(b) *Breathing apparatus.* At least two self-contained breathing apparatuses, additional to those required by 4-7-3/15.5.2, are to be provided. Two spare charges suitable for use with the breathing apparatus are to be provided for each required apparatus. Vessels that are equipped with suitably located means for fully recharging the air cylinders free from contamination need carry only one spare charge for each required apparatus. These spare bottles are to be in addition to the spare bottles required for the firefighter's outfit.

7.3.7 Portable Fire Extinguishers

Portable fire extinguishers with a total capacity of at least 12 kg (26.4 lb) of dry powder or equivalent are to be provided for the cargo spaces. These extinguishers are to be in addition to any portable fire extinguishers required elsewhere in this section.

7.3.8 Insulation of Machinery Space Boundaries

Bulkheads forming boundaries between cargo spaces and machinery spaces of category A are to be insulated to "A-60" class standard, unless the dangerous goods are stowed at least 3 m (10 ft) horizontally away from such bulkheads. Other boundaries between such spaces are to be insulated to "A-60" class standard.

7.3.9 Water Spray System

Each open ro-ro cargo space having a deck above it and each space deemed to be a closed ro-ro cargo space not capable of being sealed is to be fitted with an approved fixed pressure water-spray system for manual operation which is to protect all parts of any deck and vehicle platform in such space, except that any other fixed fire extinguishing system that has been shown by full-scale test to be no less effective may be permitted.

However, the drainage and pumping arrangements are to be such as to prevent the build-up of free surfaces. The drainage system is to be sized to remove no less than 125% of the combined capacity of both the water spraying system pumps and the required number of fire hose nozzles. The drainage system valves are to be operable from outside of the protected space at a position in the vicinity of the extinguishing system controls. Bilge wells are to be of sufficient holding capacity and are to be arranged at the side shell of the vessel at a distance from each other of not more than 40 m (131 ft) in each watertight compartment. If this is not possible, the adverse effect upon stability of the added weight and free surface of water are to be taken into account to the extent deemed necessary in the approval of stability information [see 4-7-2/7.3.1(c)].

7.3.10 Separation of Ro-Ro Spaces

In vessels having ro-ro spaces, a separation is to be provided between a closed ro-ro space and an adjacent open ro-ro space. The separation is to be such as to minimize the passage of dangerous vapours and liquids between such spaces. Alternatively, such separation need not be provided if the ro-ro space is considered to be a closed cargo space over its entire length and fully complies with the relevant special requirements of 4-7-2/7.

In vessels having ro-ro spaces, a separation is to be provided between a closed ro-ro space and the adjacent weather deck. The separation is to be such as to minimize the passage of dangerous vapours and liquids between such spaces. Alternatively, a separation need be provided if the arrangements of the closed ro-ro spaces are in accordance with those required for the dangerous goods on the adjacent weather deck.

7.5 General Cargo Vessels

For general cargo vessels whose cargo spaces are not specifically designed for the carriage of freight containers but are intended for the carriage of dangerous goods in packaged form including goods in freight containers and portable tanks, the following tables provide the applicable requirements under the provisions of 4-7-2/7.3:

- 4-7-2/Table 1 is provided for information and shows the list of dangerous goods, as defined in *IMDG Code*.
- 4-7-2/Table 2 is provided for information on dangerous goods in limited quantities, as defined in *IMDG Code*, for which the provisions of 4-7-2/7.3 need not be applied.
- 4-7-2/Table 3 provides the applicability of the requirements specified in 4-7-2/7.3.1 through 4-7-2/7.3.9 to cargo spaces and weather deck of general cargo vessels.
- 4-7-2/Table 4 provides the applicability of these requirements to each class of the dangerous goods.

7.7 Other Dry Cargo Spaces

Protection of dry cargo spaces of specific vessel types is provided in Part 5C:

Bulk carriers:	see Section 5C-3-7.
Container carriers:	see Section 5C-5-7.
Vehicle carriers and ro-ro cargo space:	see Section 5C-10-4.

7.9 Liquid Cargo Spaces and Related Spaces

Protection of liquid cargo spaces, cargo areas and cargo pump rooms and other fire safety requirements are provided in Part 5C for each specific vessel type:

Oil carriers and fuel oil carriers:	see Section 5C-1-7.
Chemical carriers:	see Section 5C-9-11.
Liquefied gas carriers:	see Section 5C-8-11.

TABLE 1
Dangerous Goods Classes

<i>Class</i>	<i>Substance</i>
1 (1.1 through 1.6)	Explosives
2.1	Flammable gases (compressed, liquefied or dissolved under pressure)
2.2	Nonflammable gases (compressed, liquefied or dissolved under pressure)
2.3	Toxic gases
3 (3.1 through 3.3)	Flammable liquids
4.1	Flammable solids
4.2	Substances liable to spontaneous combustion
4.3	Substances which, in contact with water, emit flammable gases
5.1	Oxidizing substances
5.2	Organic peroxides
6.1	Toxic substances
6.2	Infectious substances
7	Radioactive materials
8	Corrosives
9	Miscellaneous dangerous substances and articles, that is any substance which experience has shown, or may show, to be of such a dangerous character that the provisions for dangerous substance transportation are to be applied.

TABLE 2
Dangerous Goods in Limited Quantities

[Note: This is provided for information only, refers to Section 18 of General Introduction of *IMDG Code* for full details.]

<i>Class</i>	<i>Packaging Group</i>	<i>State</i>	<i>Maximum Quantity per Inner Packaging</i>
2 Excluding gases (except aerosols) of flammable, corrosive, oxidizing or toxic risks.		Gas	120 ml (maximum inner volume in metal, plastic or glass packaging) or 100 ml (aerosols)
3	II	Liquid	1 liter (metal); 500 ml for severe marine pollutants 500 ml (glass or plastic)
	III	Liquid	5 liters; 500 ml for severe marine pollutants
4.1 Excluding self-reactive and related substances and desensitized explosives.	II	Solid	500 g
	III	Solid	3 kg; 500 g for severe marine pollutants
4.3	II	Liquid	500 g
	III	or solid	1 kg; 500 g for severe marine pollutants
5.1	II	Liquid	500 g
	III	or solid	1 kg; 500 g for severe marine pollutants
5.2 The organic peroxide should be of type B or C and should not require temperature control.	II	Solid	100 g
	II	Liquid	25 ml
5.2 The organic peroxide should be of type D, E or F and should not require temperature control.	II	Solid	500 g
	II	Liquid	125 ml
6.1	II	Solid	500 g
		Liquid	100 ml
	III	Solid	3 kg; 500 g for severe marine pollutants
		Liquid	1 liter; 500 ml for severe marine pollutants
8	II	Solid	1 kg; 500 g for severe marine pollutants
		Liquid	500 ml
	III	Solid	2 kg; glass porcelain or stoneware inner packaging should be enclosed in a compatible and rigid intermediate packaging.
		Liquid	1 liter; 500 ml for severe marine pollutants
9 Excluding asbestos, polychlorinated biphenyls, polyhalogenated biphenyls, polyhalogenated terphenyls	II	Solid	3 kg; 500 g for severe marine pollutants
		Liquid	1 liter; 500 ml for severe marine pollutants
	III	Solid	5 kg; 500 g for severe marine pollutants
		Liquid	5 liter; 500 ml for severe marine pollutants

TABLE 3
Applicability of the Requirements to Cargo Vessels Carrying Dangerous Goods

<i>Requirements</i>	<i>General Cargo Spaces (see 4-7-2/7.5)</i>	<i>Weather Deck</i>
4-7-2/7.3.1(a) Availability of water	x	x
4-7-2/7.3.1(b) Quantity of water	x	x
4-7-2/7.3.1(c) Under deck cargo space cooling	x	---
4-7-2/7.3.1(d) Alternative to cooling by water	x	---
4-7-2/7.3.2 Source of ignition	x	---
4-7-2/7.3.3 Detection system	x	---
4-7-2/7.3.4(a) Ventilation –air changes	x	---
4-7-2/7.3.4(b) Ventilation – fans	x	---
4-7-2/7.3.5 Bilge pumping	x	---
4-7-2/7.3.6 Personnel protection	x	x
4-7-2/7.3.7 Portable fire extinguishers	x	x
4-7-2/7.3.8 Insulation of machinery space boundaries	x	x
4-7-2/7.3.9 Water spray system	---	---

TABLE 4
Application of the Requirements in 4-7-2/7.3 to Different Classes of Dangerous Goods Except Solid Dangerous Goods in Bulk

Dangerous Goods Class	4-7-2/Paragraph:													
	7.3.1				7.3.2	7.3.3	7.3.4		7.3.5	7.3.6	7.3.7	7.3.8	7.3.9	7.3.10
	(a)	(b)	(c)	(d)			(a)	(b)						
1.1 – 1.6	X	X	X	X	X	X	-	-	-	-	-	X ⁽²⁾	X	X
1.4S	X	X	-	-	-	X	-	-	-	-	-	-	X	X
2.1	X	X	-	-	X	X	X	X	-	X	-	X	X	X
2.2	X	X	-	-	-	X	-	-	-	X	-	X	X	X
2.3 flammable ⁽¹⁰⁾	X	X	-	-	X	-	-	-	-	X	-	X	X	X
2.3 non-flammable	X	X	-	-	-	X	X	-	-	X	-	X	X	X
3 FP ⁽⁵⁾ < 23°C	X	X	-	-	X	X	X	X	X	X	X	X	X	X
3 FP ⁽⁵⁾ ≥ 23°C to ≤ 60°C	X	X	-	-	-	X	-	-	-	X	X	X	X	X
4.1	X	X	-	-	-	X	X ⁽¹⁾	-	-	X	X	X	X	X
4.2	X	X	-	-	-	X	X ⁽¹⁾	-	-	X	X	X	X	X
4.3 liquids ⁽¹¹⁾	X	X	-	-	X ⁽⁸⁾	X	X	-	-	X	X	X	X	X
4.3 solids	X	X	-	-	-	X	X	-	-	X	X	X	X	X
5.1	X	X	-	-	-	X	X ⁽¹⁾	-	-	X	X	X ⁽³⁾	X	X
5.2 ⁽⁶⁾	X	X	-	-	-	-	-	-	-	X	-	X	X	X
6.1 liquids FP ⁽⁵⁾ < 23°C	X	X	-	-	X	X	X	X	X	X	X	X	X	X
6.1 liquids FP ⁽⁵⁾ ≥ 23°C to ≤ 60°C	X	X	-	-	-	X	X	-	X	X	X	X	X	X
6.1 liquids	X	X	-	-	-	X	-	-	X	X	-	-	X	X
6.1 solids	X	X	-	-	-	X	X ⁽¹⁾	-	-	X	-	-	X	X
8 liquids FP ⁽⁵⁾ < 23°C	X	X	-	-	X	X	X	X	X	X	X	X	X	X
8 liquids FP ⁽⁵⁾ ≥ 23°C to ≤ 60°C	X	X	-	-	-	X	X	-	X ⁽⁹⁾	X	X	X	X	X
8 liquids	X	X	-	-	-	X	-	-	X ⁽⁹⁾	X	-	-	X	X
8 solids	X	X	-	-	-	X	-	-	-	X	-	-	X	X
9	X	-	-	-	X ⁽⁷⁾	-	X ⁽¹⁾	X ⁽⁷⁾	-	X ⁽⁴⁾	-	-	X	X

Notes

- 1 When “mechanically ventilated spaces” are required by the *IMDG Code*.
- 2 Stow 3 m (10 ft) horizontally away from the machinery space boundaries in all cases.
- 3 Refer to the *IMDG Code*.
- 4 As appropriate to the goods being carried.
- 5 FP means flashpoint.
- 6 Under the provisions of the *IMDG Code*, stowage of class 5.2 dangerous goods under deck or in enclosed ro-ro spaces is prohibited.
- 7 Only applicable to dangerous goods evolving flammable vapor listed in the *IMDG Code*.
- 8 Only applicable to dangerous goods having a flashpoint less than 23°C listed in the *IMDG Code*.
- 9 Only applicable to dangerous goods having a subsidiary risk class 6.1.
- 10 Under the provisions of the *IMDG Code*, stowage of class 2.3 having subsidiary risk class 2.1 under deck or in enclosed ro-ro spaces is prohibited.
- 11 Under the provisions of the *IMDG Code*, stowage of class 4.3 liquids having a flashpoint less than 23°C under deck or in enclosed ro-ro spaces is prohibited.

PART

4

CHAPTER 7 Fire Safety Systems

SECTION 3 Fire-extinguishing Systems and Equipment

1 Fire Main Systems

1.1 General

Every vessel is to be provided with fire pumps, fire mains, hydrants and hoses complying with the provisions of this subsection, as applicable.

1.3 Capacity of Fire Pumps

1.3.1 Total Capacity

The required fire pumps are to be capable of delivering for fire fighting purposes a quantity of water, at the pressure specified in 4-7-3/1.7 not less than four-thirds ($\frac{4}{3}$) of the quantity required under 4-6-4/5.3.2 to be dealt with by each of the independent bilge pumps when employed in bilge pumping, using in all cases L = length of the vessel, except that the total required capacity of the fire pumps need not exceed 180 m³/h (792 gpm).

1.3.2 Minimum Capacity of Each Pump

Each of the required fire pumps (other than any emergency fire pump required in 4-7-3/1.5.3) is to have a capacity not less than 80% of the total required capacity divided by the minimum number of required fire pumps, but in any case not less than 25 m³/h (110 gpm) and each such pump is to be capable, in any event, of delivering at least the two required jets of water. These fire pumps are to be capable of supplying the fire main system under the required conditions. Where more pumps than the minimum of required pumps are installed, such additional pumps are to have a capacity of at least 25 m³/h (110 gpm) and are to be capable of delivering at least the two jets of water in 4-7-3/1.9.

1.5 Arrangements of Fire Pumps and of Fire Mains

1.5.1 Number of Pumps

There are to be at least two independently driven fire pumps. For vessels less than 1000 gross tonnage, only one of the required fire pumps need be independently driven. The fire pumps are to be certified in accordance with 4-6-1/7.3.1.

1.5.2 Acceptable Pumps

Sanitary, ballast, bilge or general service pumps may be accepted as fire pumps, provided that they are not normally used for pumping oil and that if they are subject to occasional duty for the transfer or pumping of oil fuel, suitable changeover arrangements are fitted.

1.5.3 Emergency Fire Pump

The arrangement of sea connections, fire pumps and their sources of power are to be such as to ensure that: if a fire in any one compartment could put all pumps required by 4-7-3/1.5.1 out of action, there is to be an alternative means consisting of a fixed independently driven power-operated emergency pump which is to be capable of supplying two jets of water. The pump and its location are to comply with the following requirements:

- i) *The capacity of the pump is not to be less than 40% of the total capacity of the fire pumps required by 4-7-3/1.3.1 and in any case not less than the following:*
- *for cargo vessels of 2000 gross tonnage and upwards: 25 m³/h, and*
 - *for cargo vessels less than 2000 gross tonnage: 15 m³/h.*

Where applicable, the emergency fire pump is also to be capable of supplying simultaneously the amount of water needed for any fixed fire-extinguishing system protecting the space containing the main fire pumps. The pump is to be self-priming.

- ii) *When the pump is delivering the quantity of water required by 4-7-3/1.5.3i), the pressure at any hydrant is to be not less than the minimum pressures given in 4-7-3/1.7.2.*
- iii) *Any diesel driven power source for the pump is to be capable of being readily started in its cold condition down to a temperature of 0°C (32°F) by hand (manual) cranking. If this is impracticable, or if lower temperatures are likely to be encountered, heating arrangements are to be provided so that ready starting will be assured. If hand (manual) starting is impracticable, other means of starting may be considered. These means are to be such as to enable the diesel driven power source to be started at least 6 times within a period of 30 minutes, and at least twice within the first 10 minutes.*

Diesel engines exceeding 15 kW are to be equipped with an approved auxiliary starting device, e.g., starting battery, independent hydraulic starting system or independent starting air system.

- iv) *Any service fuel tank is to contain sufficient fuel to enable the pump to run on full load for at least three hours and sufficient reserves of fuel are to be available outside the machinery space of category A to enable the pump to be run on full load for an additional 15 hours.*
- v) *The total suction head and net positive suction head of the pump are to be such that the requirements of 4-7-3/1.5.3i), 4-7-3/1.5.3ii) and 4-7-3/1.7.2 are obtained under all conditions of list, trim, roll and pitch likely to be encountered in service. The ballast condition of a vessel on entering or leaving a dry dock need not be considered a service condition. In selecting the emergency fire pump, the minimum available net positive suction head is to provide a safety margin of at least the 1 meter (3.3 feet) or 30% of required net positive suction head of the pump, whichever is less.*
- vi) *The space containing the emergency fire pump is not to be contiguous to the boundaries of machinery spaces of category A or those spaces containing main fire pumps. Where this is not practicable, the common bulkhead between the two spaces is to be insulated to a standard of structural fire protection equivalent to that required for a control station. The common bulkhead is to be constructed to A-60 class standard and the insulation is to extend at least 450 mm (18 in.) outside the area of the joint bulkheads and decks.*

The emergency fire pump, its seawater inlet, and suction and delivery pipes and isolating valves are to be located outside of the machinery space containing the main fire pump or pumps. The sea valve is to be operable from a position near the pump. If this arrangement cannot be made, the sea-chest may be fitted in the machinery space containing the main fire pump or pumps if the valve is remotely controlled from a position near the pump in the same compartment as the emergency fire pump and the suction pipe is to be as short as practicable. Short lengths of suction or discharge piping may penetrate the machinery space containing the main fire pump or pumps, provided they are enclosed in a substantial steel casing, or are insulated to A-60 class standard. The pipes are to have substantial wall thickness, but in no case less than 11 mm (0.433 in.), and are to be welded, except for the flanged connection to the sea inlet valve. For piping and pipe routing, see 4-7-3/1.11.3.

Interpretation (IACS)

1. "The valve" in third sentence of the second paragraph means "sea inlet valve";
2. In cases where suction or discharge piping penetrating machinery spaces are enclosed in a substantial steel casing, or are insulated to "A-60" class standards, it is not necessary to enclose or insulate "distance pieces", "sea inlet valves" and "sea-chests". For this purpose, the discharge piping means piping between the emergency fire pump and the isolating valve;

3. The method for insulating pipes to ““A-60” class standards” is that they are to be covered/protected in a practical manner by insulation material which is approved as a part of “A-60” class divisions in accordance with the FTP Code; and
 4. Where the sea inlet valve is in the machinery space, the valve should not be a fail-close type. Where the sea inlet valve is in the machinery space and is not a fail-open type, measures should be taken so that the valve can be opened in the event of fire, e.g. control piping, actuating devices and/or electric cables with fire resistant protection equivalent to “A-60” class standards.
 5. In cases where main fire pumps are provided in compartments outside machinery spaces and where the emergency fire pump suction or discharge piping penetrates such compartments, the above interpretation is to be applied to the piping.
- vii) *No direct access is to be permitted between the machinery space and the space containing the emergency fire pump and its source of power. When this is impracticable, ABS may accept an arrangement where the access is by means of an airlock with the door of the machinery space being of “A-60” class standard and the other door being at least steel, both reasonably gastight, self-closing and without any hold-back arrangements. Alternatively, the access may be through a watertight door capable of being operated from a space remote from the machinery space and the space containing the emergency fire pump and unlikely to be cut off in the event of fire in those spaces. In such cases, a second means of access to the space containing the emergency fire pump and its source of power shall be provided.*
- viii) *Ventilation arrangements to the space containing the independent source of power for the emergency fire pump are to be such as to preclude, as far as practicable, the possibility of smoke from a machinery space fire entering or being drawn into that space. The space is to be well ventilated and power for mechanical ventilation is to be supplied from the emergency source of power.*

1.5.4 Alternative to Emergency Fire Pump

An emergency fire pump is not required if the two main fire pumps including their sources of power, fuel supply, electric cables, lighting and ventilation for the space in which they are located are in separate compartments so that a fire in any one compartment will not render both main fire pumps inoperable. Only one common boundary is allowed between the two compartments, provided the common boundary is A-0 class or higher. No direct access is allowed between the two compartments, except that, where this is impracticable, an access meeting the requirements of 4-7-3/1.5.3vii) may be considered. For piping and pipe routing, see 4-7-3/1.11.3.

1.5.5 Machinery Spaces Intended for Centralized or Unattended Operation

In vessels with a periodically unattended machinery space or when only one person is required on watch, there is to be immediate water delivery from the fire main system at a suitable pressure, either by remote starting of one of the main fire pumps with remote starting from the navigating bridge and fire control station, if any, or permanent pressurization of the fire main system by one of the main fire pumps. This requirement may be waived for cargo vessels of less than 1,600 gross tonnage, provided the fire pump starting arrangement in the machinery space is in an easily accessible position. See also 4-9-5/15.5.2 and 4-9-6/21.3

1.5.6 Relief Valves

Relief valves are to be provided in conjunction with all fire pumps if the pumps are capable of developing a pressure exceeding the design pressure of the water service pipes, hydrants and hoses. These valves are to be so placed and adjusted as to prevent excessive pressure in any part of the fire main system.

1.5.7 Isolation Valves

In oil carriers and fuel oil carriers, flammable chemical carriers and gas carriers, isolation valves are to be fitted in the fire main at poop front in a protected position and on the tank deck at intervals of not more than 40 m (132 ft) to preserve the integrity of the fire main system in case of fire or explosion.

1.5.8 Additional Machinery Space Pump Connection

In cargo ships where other pumps, such as general service, bilge and ballast, etc. are fitted in a machinery space, arrangements are to be made to ensure that at least one of these pumps, having the capacity and pressure required by 4-7-3/1.3.2 and 4-7-3/1.7.2, is capable of providing water to the fire main.

1.7 Diameter and Pressure in the Fire Main

1.7.1 Fire Main Diameter

The diameter of the fire main and water service pipes is to be sufficient for the effective distribution of the maximum required discharge from two fire pumps operating simultaneously. However, the diameter need only be sufficient for the discharge of 140 m³/hour (616 gpm).

1.7.2 Fire Main Pressure

With the two pumps simultaneously delivering through nozzles specified in 4-7-3/1.15 the quantity of water specified in 4-7-3/1.7.1, through any adjacent hydrants, the following minimum pressures are to be maintained at all hydrants:

- i) Vessels of 6,000 gross tonnage and upwards: 0.27 N/mm² (2.8 kgf/cm², 40 psi);*
- ii) Vessels less than 6,000 gross tonnage: 0.25 N/mm² (2.6 kgf/cm², 37 psi).*

1.7.3 Fire Hose Handling

The maximum pressure at any hydrant is not to exceed that at which the effective control of a fire hose can be demonstrated.

1.9 Number and Position of Hydrants

The number and position of hydrants are to be such that at least two jets of water not emanating from the same hydrant, one of which is to be from a single length of hose, may reach any part of the vessel normally accessible to the passengers or crew while the vessel is being navigated and any part of any cargo space when empty, any ro-ro cargo space or any vehicle space in which latter case the two jets are to reach any part of such space, each from a single length of hose. Furthermore, such hydrants are to be positioned near the accesses to the protected spaces.

1.11 Pipes and Hydrants

1.11.1 General

Materials readily rendered ineffective by heat are not to be used for fire mains and hydrants unless adequately protected. The pipes and hydrants are to be so placed that the fire hoses may be easily coupled to them. The arrangement of pipes and hydrants is to be such as to avoid the possibility of freezing. Suitable drainage provisions are to be provided for the fire main piping. Isolation valves are to be installed for all open deck fire main branches used for purpose other than fire fighting. In vessels where deck cargo may be carried, the positions of the hydrants are to be such that they are always readily accessible and the pipes are to be arranged as far as practicable to avoid risk of damage by such cargo. Unless one hose and nozzle is provided for each hydrant in the vessel, there are to be complete interchangeability of hose couplings and nozzles.

Materials used for the firemain, hydrants and firemain components (such as valves, expansion joints, fittings, gaskets, etc., including filler materials used for associated methods of attachment) are not considered “readily rendered ineffective by heat”, provided the components made of such materials are capable of passing a recognized fire test acceptable to ABS.

1.11.2 Hydrant Valves

A valve is to be fitted to serve each fire hydrant so that any fire hose may be removed while the fire pumps are in operation.

1.11.3 Isolating Valves and Pipes Routing

Isolating valves to separate the section of the fire main within the machinery space containing the main fire pump or pumps from the rest of the fire main are to be fitted in an easily accessible and tenable position outside of the machinery spaces. The fire main is to be so arranged that when the isolating valves are shut, all of the hydrants on the vessel, except those in the machinery space referred to above, can be supplied with water by another fire pump or an emergency fire pump.

This requirement applies to a machinery space of category A only. Any part of the fire main routed through a machinery space of category A is to be fitted with isolating valves outside of the space.

1.13 Fire Hoses

1.13.1 Hose Material and Fittings

Fire hoses are to be of approved non-perishable material (certified to a recognized standard by a competent independent testing laboratory) and are to be sufficient in length to project a jet of water to any of the spaces in which they may be required to be used. Fire hoses are to have a length of at least 10 m (33 ft), but not more than:

- 15 m (50 ft) in machinery spaces;
- 20 m (66 ft) in other spaces and open decks; and
- 25 m (82 ft) for open deck on vessels with a maximum breadth in excess of 30 m (98 ft)

Each hose is to be provided with a nozzle and the necessary couplings. Fire hoses together with any necessary fittings and tools are to be kept ready for use in conspicuous positions near the water service hydrants or connections.

1.13.2 Number of Hoses

In vessels of 1,000 gross tonnage and upwards, the number of fire hoses to be provided is to be at least one for each 30 m (100 ft) length of the vessel and one spare, but in no case less than five in all. This number does not include any hoses required in any engine or boiler room. Vessels carrying dangerous goods, see 4-7-2/7.1.2, are to be provided with three hoses and nozzles, in addition to those required above. (See also 4-7-3/1.11.1 for requirements regarding interchangeability of hoses and nozzles and the requirement for additional hoses and nozzles, as necessary.) In vessels of less than 1,000 gross tonnage, the number of fire hoses to be provided is to be at least one for each 30 m (100 ft) length of the vessel and one spare. However, the number of hoses is to be in no case less than three.

1.15 Nozzles

1.15.1 Standard Nozzles

Standard nozzle sizes are to be 12 mm (0.5 in.), 16 mm (0.625 in.) and 19 mm (0.75 in.) or as near thereto as possible. Larger diameter nozzles may be permitted, subject to compliance with 4-7-3/1.7.2.

1.15.2 Nozzles for Accommodation and Service Spaces

For accommodation and service spaces, a nozzle size greater than 12 mm (0.5 in.) need not be used.

1.15.3 Nozzles for Machinery Spaces

For machinery spaces and exterior locations, the nozzle sizes are to be such as to obtain the maximum discharge possible from two jets at the pressure mentioned in 4-7-3/1.7.2 from the smallest pump, provided that a nozzle size greater than 19 mm (0.75 in.) need not be used.

1.15.4 Dual Purpose Nozzles

All nozzles are to be of an approved dual purpose type (i.e., spray/jet type) incorporating a shut-off. Nozzles of plastic material such as polycarbonate may be accepted, subject to review of their capability and serviceability as marine use fire hose nozzles.

1.17 Water Pumps for Other Fire Extinguishing Systems

Pumps, other than those serving the fire main, required for the provision of water for other fire extinguishing systems, their sources of power and their controls are to be installed outside the space or spaces protected by such systems and are to be so arranged that a fire in the space or spaces protected will not put any such system out of action.

1.19 International Shore Connection

1.19.1 General

All vessels 500 gross tons and above are to be provided with at least one international shore connection, complying with provisions of 4-7-3/1.19.3.

1.19.2 Availability on Either Side of the Vessel

Facilities are to be available enabling such a connection to be used on either side of the vessel.

1.19.3 Dimensions

Standard dimensions of flanges for the international shore connection are to be in accordance with 4-7-3/Table 1.

**TABLE 1
 Dimensions of International Shore Connection**

	SI & MKS units	US units
Outside diameter	178 mm	7 in.
Inside diameter	64 mm	2.5 in.
Bolt circle diameter	132 mm	5.2 in.
Slots in flange	4 holes 19 mm (0.75 in.) in diameters spaced equidistantly on a bolt circle of the above diameter slotted to the flange periphery.	
Flange thickness	14.5 mm minimum	0.57 in. minimum
Bolts and nuts	4 each of 16 mm diameter, 50 mm in length	4 each of 0.63 in diameter, 1.97 in. in length

1.19.4 Design

The connection is to be of steel or other suitable material and is to be designed for 1.0 N/mm² (10.5 kgf/cm², 150 psi) services. The flange is to have a flat face on one side, and on the other site, it is to be permanently attached to a coupling that will fit the vessel's hydrant and hose. The connection is to be kept aboard the vessel together with a gasket of any material suitable for 1.0 N/mm² (10.5 kgf/cm², 150 psi) services, together with four 16 mm (5/8 in.) bolts, 50 mm (2 in.) in length, four 16 mm (5/8 in.) nuts, and eight washers.

3 Fixed Gas Fire Extinguishing Systems

3.1 General

3.1.1 Non-permitted Medium

Fire extinguishing systems using Halon 1211, 1301, and 2402 and perfluorocarbons is to be prohibited. The use of a fire-extinguishing medium, which either by itself or under expected conditions of use gives off toxic gases, liquids and other substances in such quantities as to endanger persons, is not to be permitted.

3.1.2 Distribution Piping and Nozzles

The necessary pipes for conveying fire-extinguishing medium into protected spaces are to be provided with control valves, so marked as to indicate clearly the spaces to which the pipes are led. Suitable provision is to be made to prevent inadvertent release of the medium to any space. Where a cargo space fitted with a gas fire extinguishing system is used as a passenger space, the gas connection is to be blanked during such use.

The pipes may pass through accommodations provided that they are of substantial thickness and that their tightness is verified with a pressure test, after installation, at a pressure head not less than 5 N/mm² (51 kgf/cm², 725 psi). In addition, pipes passing through accommodation areas are to be joined only by welding and are not to be fitted with drains or other openings within such spaces. The pipes are not to pass through refrigerated spaces.

The piping for the distribution of fire extinguishing medium is to be arranged and discharge nozzles so positioned that a uniform distribution of medium is obtained. System flow calculations are to be performed using a calculation technique acceptable to ABS.

For CO₂ fire extinguishing systems, the wall thickness of steel piping is to be suitable for the pressure in accordance with 4-6-2/5.1 and not less than the thickness identified in 4-7-3/Table 2. Column A is for piping from storage containers to distribution station, and column B is for piping from distribution station to nozzles. For other fixed gas fire extinguishing systems, calculations showing compliance with 4-6-2/5 is to be submitted for approval.

The pressure rating of pipe connections such as flanges from the distribution aftermost valve to discharge nozzles is to be not less than the maximum pressure developed during the discharge of CO₂ into protected spaces.

Where the fire-extinguishing medium is used as the power source for the pre-discharge alarm, the piping to the alarm is to comply with Column B of the 4-7-3/Table 2.

For safety valves discharge arrangement see 4-6-2/9.9.3. In addition, in piping sections where valve arrangements introduce sections of closed piping, such sections are to be fitted with a pressure relief valve and the outlet of the valve is to be led to open deck.

For prohibition of gray cast iron piping components, see 4-6-2/3.1.3.

All discharge piping, fittings and nozzles in the protected spaces are to be constructed of materials having a melting temperature which exceeds 925°C (1697°F). The piping and associated equipment are to be adequately supported.

A fitting is to be installed in the discharge piping to permit the air testing as required by 4-7-3/3.3.6.

Threaded joints in CO₂ systems are to be allowed only inside protected spaces and in CO₂ cylinder rooms. See 4-6-2/5.5.5(a) for limitations.

TABLE 2
Minimum Steel Pipe Wall Thickness for CO₂
Medium Distribution Piping

Nominal size, mm	OD mm	A mm	B mm	Nominal size, in.	OD in.	A in.	B in.
15	21.3	2.8	2.6	1/2	0.840	0.110	0.102
20	26.9	2.8	2.6	3/4	1.050	0.110	0.102
25	33.7	4.0	3.2	1	1.315	0.157	0.126
32	42.4	4.0	3.2	1 1/4	1.660	0.157	0.126
40	48.3	4.0	3.2	1 1/2	1.9	0.157	0.126
50	60.3	4.5	3.6	2	2.375	0.177	0.142
65	76.1	5.0	3.6	2 1/2	2.875	0.197	0.142
80	88.9	5.5	4.0	3	3.5	0.220	0.157
90	101.6	6.3	4.0	3 1/2	4.0	0.248	0.157
100	114.3	7.1	4.5	4	4.5	0.28	0.177
125	139.7	8.0	5.0	5	5.563	0.315	0.197
150	168.3	8.8	5.6	6	6.625	0.346	0.22

Notes:

- 1 The above minimum thicknesses are derived from those thicknesses available in ISO 4200 Series 1 (OD), JIS (N.P.S.), or ASTM (N.P.S.). Diameter and thickness according to other recognized standards will be accepted.
- 2 For threaded pipes, where approved, the thickness is to be measured to the bottom of the thread.
- 3 The internal surface of pipes outside of the engine room is to be galvanized.
- 4 For larger diameters the minimum wall thickness will be subject to special consideration by ABS.
- 5 In general, the minimum thickness is the nominal wall thickness and no allowance need be made for negative tolerance or reduction in thickness due to bending.

3.1.3 Openings in Protected Space

Where a fixed gas fire-extinguishing system is used, openings which may admit air to, or allow gas to escape from a protected space, are to be capable of being closed from outside of the protected space.

A pressure switch or other device is to be provided to automatically shut down power ventilation serving the protected space prior to the discharge of the agent into the space. Pressure switches or other devices are to be located outside of the protected space.

3.1.4 Air Reservoirs

The volume of starting air receivers converted to free air volume is to be added to the gross volume of the machinery space when calculating the necessary quantity of the extinguishing medium. Alternatively, a discharge pipe from the safety relief valves or other pressure relief devices may be fitted and led directly to the open air.

3.1.5 Medium Release Warning Alarm

Means are to be provided for automatically giving audible and visual warning of the release of fire extinguishing medium into any ro-ro spaces, container holds equipped with integral reefer containers, spaces accessible by doors or hatches, and other spaces in which personnel normally work or to which they have access. The audible alarms are to be located so as to be audible throughout the protected space with all machinery operating, and the alarms are to be distinguished from other audible alarms by adjustment of sound pressure or sound patterns. The pre-discharge alarm is to be automatically activated, e.g. by opening of the release cabinet door. The alarm is to operate for the length of time needed to evacuate the space, but in no case less than 20 seconds before the medium is released.

Conventional cargo spaces and small spaces (such as small compressor rooms, paint lockers, lamp stores, etc.) with only a local release need not be provided with such an alarm. Conventional cargo spaces means cargo spaces other than ro-ro spaces or container holds equipped with integral reefer containers, and they need not be provided with means for automatically giving audible and visual warning of the release.

Alarms may be pneumatically (by the extinguishing medium or by air) or electrically operated. If electrically operated, the alarms are to be supplied with power from the main and an emergency source of power. If pneumatically operated by air, the air supplied is to be dry and clean and the supply reservoir is to be fitted with a low pressure alarm. The air supply may be taken from the starting air receivers. Any stop valve fitted in the air supply line is to be locked or sealed in the open position. Any electrical components associated with the pneumatic system are to be powered from the main and an emergency source of electrical power.

For fire extinguishing systems that protect the machinery space (containing the main source of power), instead of the power supply arrangements required above for electrically operated alarms and electrical components associated with pneumatic alarms, an uninterruptible power supply which is supplied with power from the emergency switchboard is to be provided.

3.1.6 Location of Controls for Medium Release

3.1.6(a) General. The means of control of any fixed gas fire extinguishing system are to be readily accessible and simple to operate and are to be grouped together in as few locations as possible at positions not likely to be cut off by a fire in a protected space. At each location, there are to be clear instructions relating to the operation of the system, having regard to the safety of personnel. See also 4-7-3/3.3.5.

3.1.6(b) Machinery Spaces. For category A machinery spaces, there are to be at least two locations where the release controls are provided, one of which is to be at the storage location while the other is to be at a readily accessible location outside the protected space.

3.1.6(c) Cargo Holds. Controls for the release of the fixed gas fire extinguishing medium for cargo holds, may be arranged in a single location, local at the storage location or remote, such that the location would not likely be cut off by a fire in a protected cargo hold.

Where access to the release controls at the storage location could be cut off by a fire in a protected cargo hold, remote controls for the release of the media are to be provided.

The remote controls are to be arranged as follows:

- i) To be of robust construction or so protected as to remain operable in case of fire in the protected spaces, and*
- ii) To be placed in the accommodation area in order to facilitate their ready accessibility by the crew*

The capability to release different quantities of fire-extinguishing media into different cargo holds so protected is to be included in the remote release arrangement.

3.1.7 Automatic Release of Fire Extinguishing Medium

Automatic release of fire extinguishing medium is not permitted, except as may be specifically approved based on the use of an extinguishing medium that does not give off toxic gases, liquid or other substances that would endanger personnel, see 4-7-3/3.9.

3.1.8 Systems Protecting More than One Space

Where the quantity of extinguishing medium is required to protect more than one space, the quantity of medium available need not be more than the largest quantity required for any one space so protected. The system is to be fitted with normally closed control valves arranged to direct the agent into the appropriate space. Adjacent spaces with independent ventilation systems not separated by at least A-0 class divisions are to be considered as the same space.

3.1.9 Storage of Medium Containers

- i) Except as otherwise permitted, pressure containers required for the storage of fire extinguishing medium, other than steam, are to be located outside the protected spaces. When the fire-extinguishing medium is stored outside a protected space, it is to be stored in a room, which is located behind the forward collision bulkhead, and is used for no other purposes. Any entrance to such a storage room is to preferably be from the open deck and is to be independent of the protected space. If the storage space is located below deck, it is to be located no more than one deck below the open deck and is to be directly accessible by a stairway or ladder from the open deck. Spaces which are located below deck or spaces where access from the open deck is not provided are to be fitted with a mechanical ventilation system designed to take exhaust air from the bottom of the space, and is to be sized to provide at least 6 air changes per hour. Access doors are to open outwards, and bulkheads and decks including doors and other means of closing any opening therein which form the boundaries between such rooms and adjoining enclosed spaces are to be gastight. The boundaries of the room is to have fire-rated integrity equivalent to that of a control station (see Section 3-4-1). The ventilation for the storeroom is to be independent of all other spaces.*

- ii) Fire-extinguishing media protecting the cargo holds (see 4-7-2/7.1.1) is to be stored in a dedicated room within or adjacent to accommodation area. Alternatively, the fire-extinguishing media may be stored in a room located forward or afterward of the cargo holds, but aft of the collision bulkhead. See 4-7-3/3.1.6 for location of controls for medium release.
- iii) Where the CO₂ system discharge piping is also used for the sample extraction smoke detection system piping, see 4-7-3/13.7.1(b) for the location of the indicating unit.

3.1.10 Medium Quantity Check

Means are to be provided for the crew to safely check the quantity of medium in the containers. It is not to be necessary to move the containers completely from their fixing position for this purpose. For carbon dioxide systems, hanging bars for a weighing device above each bottle row, or other means are to be provided. For other types of extinguishing media, suitable surface indicators may be used.

3.1.11 Fire Extinguishing Medium Containers Design

Containers for the storage of fire extinguishing medium and associated pressure components are to be designed in accordance with requirements for pressure vessels in Section 4-4-1; see in particular, 4-4-1/1.11.4.

3.3 CO₂ Systems

3.3.1 Quantity of CO₂ for Cargo Spaces

For cargo spaces, the quantity of carbon dioxide available is to be, unless otherwise provided, sufficient to give a minimum volume of free gas equal to 30% of the gross volume of the largest cargo space to be protected in the vessel.

3.3.2 Quantity of CO₂ for Machinery Spaces

For machinery spaces, the quantity of carbon dioxide carried is to be sufficient to give a minimum volume of free gas equal to the larger of the following volumes, either:

- i) *40% of the gross volume of the largest machinery space so protected, the volume to exclude that part of the casing above the level at which the horizontal area of the casing is 40% or less of the horizontal area of the space concerned taken midway between the tank top and the lowest part of the casing; or*
- ii) *35% of the gross volume of the largest machinery space protected, including the casing;*

The above mentioned percentages may be reduced to 35% and 30%, respectively, for cargo vessels of less than 2000 gross tonnage where two or more machinery spaces, which are not entirely separate, are considered as forming one space.

3.3.3 CO₂ Unit Volume

For the purpose of this paragraph, the volume of free carbon dioxide is to be calculated at 0.56 m³/kg (9 ft³/lb).

3.3.4 CO₂ Discharge Rate

For machinery spaces, the fixed piping system is to be such that 85% of the gas can be discharged into the space within 2 minutes.

For container and general cargo spaces (primarily intended to carry a variety of cargoes separately secured or packed) the fixed piping system is to be such that at least two thirds of the gas can be discharged into the space within 10 min. For solid bulk cargo spaces the fixed piping system is to be such that at least two thirds of the gas can be discharged into the space within 20 min. The system controls are to be arranged to allow one third, two thirds or the entire quantity of gas to be discharged based on the loading condition of the hold.

The above may be verified by calculations.

3.3.5 Controls

Precautions are to be made to prevent the inadvertent release of CO₂ into spaces which are required, see 4-7-3/3.1.5, to be provided with means to automatically give an audible warning of the release of fire extinguishing medium. For this purpose, the following arrangements are to be complied with for *carbon dioxide systems for the protection of ro-ro spaces, container holds equipped with integral reefer containers, spaces accessible by doors or hatches, and other spaces in which personnel normally work or to which they have access:*

- i) *Two separate controls are to be provided at each release location for releasing CO₂ into a protected space and to ensure the activation of the alarm. One control is to be used for opening the valve of the piping which conveys the gas into the protected space and a second control is to be used to discharge the gas from its storage containers. Positive means are to be provided so the controls can only be operated in that order.*
- ii) *The two controls are to be located inside a release box clearly identified for the particular space. If the box containing the controls is to be locked, a key to the box is to be in a break-glass type enclosure conspicuously located adjacent to the box.*
- iii) *Systems are to be designed so that opening of the door to a CO₂ release mechanism will not cause an inadvertent blackout condition in machinery spaces.*

3.3.6 Testing of the Installation

When the system has been installed, pressure-tested and inspected, the following are to be carried out:

- i) *a test of the free air flow in all pipes and nozzles; and*
- ii) *a functional test of the alarm equipment.*

3.5 Refrigerated Low-pressure CO₂ Systems

The use of refrigerated CO₂ as a fire-extinguishing medium, at a pressure of 18 to 22 bar (260 to 320 lb/in²) in the storage condition, is to be in accordance with 4-7-3/3.1 and 4-7-3/3.3 and the following additional requirements.

3.5.1 Plans and Data to be Submitted

The system control devices and the refrigerating plants are to be located within the same room where the pressure containers are stored.

- System schematic arrangement
- CO₂ capacity and flow calculations
- System control and alarm arrangement
- Arrangement of CO₂ containers and refrigerating plant
- Construction details of CO₂ containers
- Manufacturer's specifications for compressor, condenser, receiver, evaporator, etc.
- Piping diagram for refrigerating system
- Electrical wiring diagrams

3.5.2 CO₂ Containers

3.5.2(a) Capacity. The rated amount of liquid carbon dioxide is to be stored in container(s) under the working pressure in the range of 18 to 22 bar (260 to 320 lb/in²). The normal liquid charge in the container is to be limited to provide sufficient vapor space to allow for expansion of the liquid under the maximum storage temperatures that can be obtained corresponding to the setting of the pressure relief valves but is not to exceed 95% of the volumetric capacity of the container.

3.5.2(b) *Design and construction.* CO₂ containers are to be designed, constructed, and tested in accordance with the requirements of Section 4-4-1; see in particular 4-4-1/1.11.4.

3.5.2(c) *Instrumentation and alarms.* Each container is to be fitted with the following instruments and alarms at the storage location:

- *Pressure gauge*
- *High pressure alarm set at not more than the relief valve setting*
- *Low pressure alarm set at not less than 18 bar (260 lb/in²)*
- *Level indicator fitted on the container(s)*
- *Any one of the refrigerating units fails to operate*
- *The lowest permissible level of the liquid in the container(s) is reached.*

A summary alarm for any of these alarm conditions is also to be given in the manned propulsion machinery space or the centralized control station (see 4-9-5/7 and 4-9-6/9), as appropriate. In the case of unattended propulsion machinery space, an additional summary alarm is to be given in the engineers' accommodation area (see 4-9-6/19).

3.5.2(d) *Relief valves.* The two safety relief valves are to be arranged so that either valve can be shut off while the other is connected to the container. The setting of the relief valves is not to be less than 1.1 times the working pressure. The capacity of each valve is to be such that the vapors generated under fire conditions can be discharged with a pressure rise not more than 20% above the setting pressure. The discharge from the safety valves is to be led to the open air.

3.5.2(e) *Insulation.* The container(s) and outgoing pipes permanently filled with carbon dioxide are to have thermal insulation preventing the operation of the safety valve in 24 h after de-energizing the plant, at ambient temperature of 45°C (113°F) and an initial pressure equal to the starting pressure of the refrigeration unit. Where porous or fibrous insulation materials are used, they are to be protected by impervious sheaths from deterioration by moisture.

3.5.2(f) *Main Shutoff Valve.* The container main shutoff valve is to be kept locked open (LO) at all times. The valve is to be provided with a means to indicate whether the valve is open or closed. The indicator is to rely on movement of the valve spindle.

3.5.3 Refrigerating Plant

3.5.3(a) *Duplication of plant.* The container(s) is(are) to be serviced by two automated completely independent refrigerating units solely intended for this purpose, each comprising a compressor and the relevant prime mover, evaporator and condenser. Provision is to be made for local manual control of the refrigerating plant. Upon failure or stoppage of the unit in operation, the other unit is to be put into operation automatically. This changeover is to be alarmed at the manned propulsion machinery space or the centralized control station, as appropriate; and, in the case of unattended propulsion machinery space, at the engineers' accommodation. See also 4-7-3/3.5.2(c). Each electric refrigerating unit is to be supplied from the main switchboard busbars by a separate feeder.

3.5.3(b) *Performance criteria.* The refrigerating capacity and the automatic control of each unit are to be so as to maintain the required temperature under conditions of continuous operation during 24 h at sea temperatures up to 32°C (90°F) and ambient air temperatures up to 45°C (113°F). See also insulation requirement in 4-7-3/3.5.2(e).

3.5.3(c) *Cooling water supply.* Cooling water supply to the refrigerating plant (where required) is to be provided from at least two circulating pumps one of which being used as a stand-by. The stand-by pump may be a pump used for other services so long as its use for cooling would not interfere with any other essential service of the vessel. Cooling water is to be taken from not less than two sea connections, preferably one port and one starboard.

3.5.4 Piping

3.5.4(a) General. Pipes, fittings, and pipe joints are to be designed, fabricated and tested, and to be of materials according to the piping classes to be determined in accordance with 4-6-1/5. *Branch pipes with stop valves for filling the container are to be provided.*

3.5.4(b) CO₂ distribution piping. CO₂ flow from storage containers to the discharge nozzle is to be in liquid phase. The design pressure at the nozzle is not to be less than 10 bar (145 lb/in²).

3.5.4(c) Safety relief valve. *Safety relief devices are to be provided in each section of pipe that may be isolated by block valves and in which there could be a buildup of pressure in excess of the design pressure of any of the components.* See 4-6-2/9.9.3 and 4-7-3/3.1.2 for safety valves discharge arrangement.

3.5.5 CO₂ Release Control

In addition to the requirements in 4-7-3/3.1.6 and 4-7-3/3.3.5, the following are to be complied with as appropriate.

3.5.5(a) Automatic regulation of gas. *If a device is provided which automatically regulates the discharge of the rated quantity of carbon dioxide into the protected spaces, it is to be also possible to regulate the discharge manually.*

3.5.5(b) Disallowed types of control devices. Electrically operated controls for CO₂ release and the quantity regulation are not permitted.

3.5.5(c) Emergency control. If an emergency release control is provided, in addition to the normal release control, it must not by-pass the activation of alarm required by 4-7-3/3.1.5. It may, however, by-pass the automatic gas regulator [see 4-7-3/3.5.5(a)], provided that it is possible at the emergency release control position to control the amount of gas to be released and to close the master valve, or equivalent, after the designated amount is released.

3.5.5(d) Multiple spaces. *If the system serves more than one space, means for control of discharge quantities of CO₂ are to be provided, e.g., automatic timer or accurate level indicators located at the control position(s).*

3.5.5(e) Instructions. Instructions for release control, as required by 4-7-3/3.1.6, are to be posted at each location where gas can be released. This is to include instructions for manual means of regulating the amount of gas to be released into each of the protected spaces.

3.7 Steam Systems

In general, the use of steam as a fire-extinguishing medium in fixed fire extinguishing systems is not permitted. Where the use of steam is permitted by ABS, it is to be used only in restricted areas as an addition to the required fire-extinguishing system and it is to comply with the following requirements.

The boiler or boilers available for supplying steam shall have an evaporation of at least 1 kg (2.2 lb) of steam per hour for each 0.75 m³ (27 ft³) of the gross volume of the largest space so protected. In addition to complying with the foregoing requirements, the systems in all respects are to be as determined by and to the satisfaction of ABS.

3.9 Equivalent Fixed Gas Fire-Extinguishing Systems for Machinery Spaces and Cargo Pump Rooms

Fixed gas fire-extinguishing systems equivalent to those specified in 4-7-3/3.3 through 4-7-3/3.7 are to be submitted for approval, based on the guidelines developed by IMO.*

** Refer to the Revised guidelines for the approval of equivalent fixed gas fire-extinguishing systems, as referred to in SOLAS 74, for machinery spaces and cargo pump-rooms (MSC/ Circ.848) and the Guidelines for the approval of fixed aerosol fire-extinguishing systems equivalent to fixed gas fire-extinguishing systems, as referred to in SOLAS 74, for machinery spaces (MSC/Circ.1007).*

3.11 Clean Agent Fire Extinguishing Systems

Fixed gas fire-extinguishing systems equivalent to those specified in 4-7-3/3.1 through 4-7-3/3.9 are to be submitted for approval, based on the guidelines specified in the IMO MSC/Circ. 848 as amended by MSC/Circ. 1267 and this subsection.

Fire extinguishing systems using Halon 1211, 1301, and 2402 and perfluorocarbons are prohibited. The use of a fire-extinguishing medium, which either by itself or under expected conditions of use gives off toxic gases, liquids and other substances in such quantities as to endanger persons, is not permitted.

3.11.1 Fire Suppression Agent

The agent is to be recognized as a fire extinguishing medium by NFPA Standard 2001 or other recognized national standard. The minimum extinguishing concentration for net volume total flooding of the protected space at the lowest expected operating temperature, but not greater than 0°C (32°F), is to be determined by an acceptable cup burner test. The minimum design concentration is to be at least 30% above the minimum extinguishing concentration and is to be verified by full-scale test (see 4-7-3/3.11.2).

The fire extinguishing agent is to be acceptable for use in occupied spaces by U.S. EPA or other recognized national organization. The concentrations for cardiac sensitization NOAEL (No Observed Adverse Effect Level), LOAEL (Lowest Observed Adverse Effect Level) and ALC (Approximate Lethal Concentration) are to be submitted.

3.11.2 Fire Tests

The system is to pass the fire tests in the Appendix of the IMO MSC/Circ. 848 as amended by MSC/Circ. 1267. The testing is to include the system components.

The system is to pass an additional fire test (number 1 in the Appendix of MSC/Circ. 848) with the agent storage cylinder at the lowest expected operating temperature, but not greater than 0°C (32°F).

3.11.3 System Components

The system is to be suitable for use in a marine environment. Major components (valves, nozzles, etc.) are to be made of brass or stainless steel, piping is to be corrosion resistant (stainless steel or galvanized) and the material is to have a melting point of not less than 927°C (1700°F).

The system and its components are to be designed, manufactured and installed in accordance with recognized national standards.

Containers and associated pressure components are to be designed based upon an ambient temperature of 55°C (131°F).

Minimum wall thickness for distribution piping is to be in accordance with 4-7-3/Table 2 (Columns A or B, as applicable).

3.11.4 System Installation

3.11.4(a) Storage. As far as practicable, the fire suppression agent is to be stored outside the protected space in a dedicated storeroom. The storeroom is to be in accordance with 4-7-3/3.1.9, except that when mechanical ventilation is provided, the location of the exhaust duct (suction) is dependent on the density of the agent relative to air.

When allowed by the Flag Administration, the fire suppression agent may be stored inside the protected space. In addition to the related instructions from the Flag Administration, the installation is to be in accordance with paragraph 11 of IMO MSC/Circ. 848 as amended by MSC/Circ. 1267.

In the case of new installation in existing units, the storage of the fire suppression agent within a low fire risk space with a net volume at least two (2) times greater than the net volume of the protected space may be specially considered, based on the type of agent and the possible hazards for the personnel within the space.

3.11.4(b) Alarm. An audible and visual predischage alarm in accordance with 4-7-3/3.1.5 and paragraph 6 of IMO MSC/Circ. 848 as amended by MSC/Circ. 1267 is to be provided.

3.11.4(c) *Controls.* Except as otherwise permitted herein two independent manual control arrangements are to be provided, one of them being positioned at the storage location and the other in a readily accessible position outside of the protected space.

Automatic actuation is not permitted when the protected space is normally manned or interferes with the safety navigation of the vessel. If the protected space is normally unmanned and may be entered occasionally for brief periods such as for repairs, maintenance or other purpose, automatic actuation may be allowed in addition to manual actuation, provided that the following conditions are met:

- i) The egress from the protected space is horizontal. Exit doors from the spaces are to be outward-swinging self-closing doors (i.e., opening in the direction of escape routes) which can be opened from the inside, including when the doors are locked from the outside.
- ii) Notices that the space is protected by an automatic activation system are prominently posted at the entrance to the space.
- iii) A switch is provided near the entrance to disable the automatic release feature of the system. The switch is to have an indicator of its status such as red pilot light to indicate when the switch is activated (automatic release feature disabled). A sign is to be posted near the switch indicating that the automatic release feature is to be disabled when the space is occupied and that the automatic actuation is to be enabled when leaving the space. The sign is to also indicate that the manual release of the system remains enabled and the space is to be vacated immediately when the release alarm sounds.
- iv) When the automatic release feature is disabled, all other controls, alarms, etc., are to remain activated.
- v) An indicator at the control console is provided to indicate when the automatic release feature has been disabled.
- vi) The medium release warning alarm is to operate for the length of time needed to evacuate the space, but in no case less than 30 seconds for space exceeding 6000 ft³ (170 m³) and 20 seconds for spaces 6000 ft³ (170 m³) or less before the medium is released.
- vii) The automatic release of a clean agent fire extinguishing system is to be approved by the vessel's flag Administration.

3.11.4(d) *Nozzles.* The nozzle type, maximum nozzle spacing, maximum height and minimum nozzle pressure are to be within the limits to provide fire extinction as tested and verified in the appropriate fire test (see 4-7-3/3.11.2).

5 Fixed Foam Fire Extinguishing Systems

5.1 Fixed High-expansion Foam Fire Extinguishing Systems in Machinery Spaces

5.1.1 General

Fixed foam fire-extinguishing systems shall be capable of generating foam suitable for extinguishing oil fires.

The foam concentrates of high-expansion foam fire-extinguishing systems is to be approved by ABS based on the guidelines developed by the IMO.*

** Refer to the Guidelines for the performance and testing criteria and surveys of high-expansion foam concentrates for fixed fire-extinguishing systems (MSC/Circ.670).*

5.1.2 Quantity and Performance of Foam Concentrates

Any required fixed high-expansion foam system in machinery spaces is to be capable of rapidly discharging through fixed discharge outlets a quantity of foam sufficient to fill the greatest space to be protected at a rate of at least 1 m (3.3 ft) in depth per minute. The quantity of foam-forming liquid available is to be sufficient to produce a volume of foam equal to five times the volume of the largest space to be protected. The expansion ratio of the foam is not to exceed 1,000:1.

ABS may permit alternative arrangements and discharge rates provided that it is satisfied that equivalent protection is achieved.

5.1.3 Installation Requirements

5.1.3(a) *Foam Distribution.* Supply ducts for delivering foam, air intakes to the foam generator and the number of foam-producing units shall, in the opinion of ABS, be such as will provide effective foam production and distribution.

5.1.3(b) *Arrangement of Foam Equipment.* The arrangement of the foam generator delivery ducting is to be such that a fire in the protected space will not affect the foam generating equipment. If the foam generators are located adjacent to the protected space, foam delivery ducts are to be installed to allow at least 450 mm (17.72 in.) of separation between the generators and the protected space. The foam delivery ducts are to be constructed of steel having a thickness of not less than 5 mm (0.197 in.). In addition, stainless steel dampers (single or multi-bladed) with a thickness of not less than 3 mm (0.118 in.) are to be installed at the openings in the boundary bulkheads or decks between the foam generators and the protected space. The dampers are to be automatically operated (electrically, pneumatically or hydraulically) by means of remote control of the foam generator related to them.

5.1.3(c) *Foam Generator and Controls.* The foam generator, its sources of power supply, foam-forming liquid and means of controlling the system are to be readily accessible and simple to operate and are to be grouped in as few locations as possible at positions not likely to be cut off by a fire in the protected space.

5.1.4 Fixed Foam Systems Using Inside Air

Fixed foam fire-extinguishing systems using inside air are to be designed, constructed and tested in accordance with the requirements identified in MSC.1/Circ. 1271 *Guidelines for the Approval of High-Expansion Foam Systems Using Inside Air for the Protection of Machinery Spaces and Cargo Pump-Rooms.*

5.3 Fixed Low-expansion Foam Fire Extinguishing System in Machinery Spaces

5.3.1 General

Fixed foam fire-extinguishing systems are to be capable of generating foam suitable for extinguishing oil fires.

*The foam concentrates of low-expansion foam fire-extinguishing systems are to be approved by the ABS based on the guidelines developed by the IMO.**

** Refer to the Guidelines for the performance and testing criteria, and surveys of low-expansion foam concentrates for fixed fire-extinguishing systems (MSC/Circ.582 and Corr.1).*

5.3.2 Quantity and Foam Concentrates

The system is to be capable of discharging through fixed discharge outlets in not more than 5 min a quantity of foam sufficient to cover to a depth of 150 mm (5.9 in.) over the largest single area over which oil fuel is liable to spread. The expansion ratio of the foam is not to exceed 12 to 1.

5.3.3 Installation Requirements

5.3.3(a) *Foam Distribution.* Means are to be provided for the effective distribution of the foam through a permanent system of piping and control valves or cocks to suitable discharge outlets, and for the foam to be effectively directed by fixed sprayers onto other main fire hazards in the protected space. The means for effective distribution of the foam are to be proven acceptable to ABS through calculation or by testing.

5.3.3(b) *Controls.* The means of control of any such systems are to be readily accessible and simple to operate and shall be grouped together in as few locations as possible at positions not likely to be cut off by a fire in the protected space.

5.5 Fixed Foam Fire Extinguishing System Outside Machinery Spaces

When a foam fire extinguishing system is installed in any other space than a machinery space, the system should meet the requirements of 4-7-3/5.1 or 4-7-3/5.3.

7 Fixed Pressure Water-spraying and Water-mist Fire Extinguishing Systems in Machinery Spaces

7.1 Fixed Pressure Water-spraying Fire Extinguishing System

Fixed-pressure water-spraying fire-extinguishing systems for machinery spaces are to be designed, constructed and tested in accordance with the requirements identified in IMO MSC/Circ. 1165 *Revised Guidelines for the Approval of Equivalent Water-based Fire-extinguishing Systems for Machinery Spaces and Cargo Pump-rooms (As Amended)*.

7.3 Equivalent Water-mist Fire-extinguishing Systems

Water-mist fire-extinguishing systems for machinery spaces are to be designed, constructed and tested in accordance with the requirements identified in IMO MSC/Circ. 1165 *Revised Guidelines for the Approval of Equivalent Water-based Fire-extinguishing Systems for Machinery Spaces and Cargo Pump-rooms (As Amended)*.

9 Automatic Sprinkler, Fire Detection and Fire Alarm Systems

9.1 General

9.1.1 Type of Sprinkler Systems

The automatic sprinkler systems are to be of the wet pipe type, but small exposed sections may be of the dry pipe type where, in the opinion of the ABS, this is a necessary precaution. Saunas are to be fitted with a dry pipe system, with sprinkler heads having an operating temperature up to 140°C (284°F).

9.1.2 Sprinkler Systems Equivalency

*Automatic sprinkler systems equivalent to those specified in 4-7-3/9.3 to 4-7-3/9.9 are to be approved by ABS based on the guidelines developed by IMO.**

** Refer to the Revised guidelines for approval of sprinkler systems equivalent to that referred to in SOLAS regulation II-2/12, as adopted by IMO in resolution A.800(19).*

9.3 Sources of Power Supply

There are not to be less than two sources of power supply for the seawater pump and automatic alarm and detection system. If the pump is electrically driven, it is to be connected to the main source of electrical power, which shall be capable of being supplied by at least two generators. The feeders are to be so arranged as to avoid galleys, machinery spaces and other enclosed spaces of high fire risk except in so far as it is necessary to reach the appropriate switchboards. One of the sources of power supply for the alarm and detection system is to be an emergency source. Where one of the sources of power for the pump is an internal combustion engine, it is to, in addition to complying with the provisions of 4-7-3/9.7.3, be so situated that a fire in any protected space will not affect the air supply to the machinery.

See 5C-7-6/5.9 for passenger vessels requirements.

9.5 Component Requirements

9.5.1 Sprinklers

9.5.1(a) Operation Range. The sprinklers are to be resistant to corrosion by the marine atmosphere. In accommodation and service spaces the sprinklers shall come into operation within the temperature range from 68°C (154°F) to 79°C (174°F),, except that in locations such as drying rooms, where high ambient temperatures might be expected, the operating temperature may be increased by not more than 30°C (54°F) above the maximum deckhead temperature.

9.5.1(b) Quantity. A quantity of spare sprinkler heads is to be provided for all types and ratings installed on the ship as follows:

Total number of heads	Required number of spares
<300	6
300 to 1000	12
>1000	24

The number of spare sprinkler heads of any type need not exceed the total number of heads installed of that type.

9.5.2 Pressure tanks

9.5.2(a) *Tank Volume.* A pressure tank having a volume equal to at least twice that of the charge of water specified in this paragraph shall be provided. The tank is to contain a standing charge of fresh water, equivalent to the amount of water which would be discharged in 1 min by the pump referred to in 4-7-3/9.5.3(b), and the arrangements are to provide for maintaining an air pressure in the tank such as to ensure that where the standing charge of fresh water in the tank has been used the pressure will be not less than the working pressure of the sprinkler, plus the pressure exerted by a head of water measured from the bottom of the tank to the highest sprinkler in the system.

Suitable means of replenishing the air under pressure and of replenishing the fresh water charge in the tank is to be provided. A glass gauge shall be provided to indicate the correct level of the water in the tank.

9.5.2(b) *Tank Protection.* Means are to be provided to prevent the passage of seawater into the tank.

9.5.3 Sprinkler Pumps

9.5.3(a) *Pump Independence.* An independent power pump is to be provided solely for the purpose of continuing automatically the discharge of water from the sprinklers. The pump is to be brought into action automatically by the pressure drop in the system before the standing fresh water charge in the pressure tank is completely exhausted.

9.5.3(b) *Pump Capability.* The pump and the piping system are to be capable of maintaining the necessary pressure at the level of the highest sprinkler to ensure a continuous output of water sufficient for the simultaneous coverage of a minimum area of 280 m² (3050 ft²) at the application rate specified in 4-7-3/9.2(c). The hydraulic capability of the system is to be confirmed by the review of hydraulic calculations by ABS, followed by a test of the system by the Surveyor.

9.5.3(c) *Pump Test.* The pump is to have fitted on the delivery side a test valve with a short open-ended discharge pipe. The effective area through the valve and pipe shall be adequate to permit the release of the required pump output while maintaining the pressure in the system specified in 4-7-3/9.5.2(a).

9.5.3(d) *Pump Certification.* The sprinkler system pump is to be certified in accordance with 4-6-1/7.3.1i).

9.7 Installation Requirements

9.7.1 General

Any parts of the system which may be subjected to freezing temperatures in service are to be suitably protected against freezing.

9.7.2 Piping Arrangements

9.7.2(a) *Sprinklers Grouping.* Sprinklers are to be grouped into separate sections, each of which shall contain not more than 200 sprinklers. In passenger ships, any section of sprinklers shall not serve more than two decks and shall not be situated in more than one main vertical zone. However, ABS may permit such a section of sprinklers to serve more than two decks or be situated in more than one main vertical zone, if it is satisfied that the protection of the vessel against fire will not thereby be reduced.

9.7.2(b) *Isolation.* Each section of sprinklers is to be capable of being isolated by one stop-valve only. The stop-valve in each section is to be readily accessible in a location outside of the associated section or in cabinets within stairway enclosures. The valve's location is to be clearly and permanently indicated. Means are to be provided to prevent the operation of the stop-valves by any unauthorized person.

9.7.2(c) *Test Valve.* A test valve is to be provided for testing the automatic alarm for each section of sprinklers by a discharge of water equivalent to the operation of one sprinkler. The test valve for each section is to be situated near the stop-valve for that section.

9.7.2(d) *Connection to Fire Main.* The sprinkler system is to have a connection from the ship's fire main by way of a lockable screw-down non-return valve at the connection which will prevent a backflow from the sprinkler system to the fire main.

9.7.2(e) *Pressure Gauge.* A gauge indicating the pressure in the system is to be provided at each section stop-valve and at a central station.

9.7.2(f) *Sea Inlet.* The sea inlet to the pump is to wherever possible be in the space containing the pump and is to be so arranged that when the ship is afloat it will not be necessary to shut off the supply of seawater to the pump for any purpose other than the inspection or repair of the pump.

9.7.3 Location of Systems

The sprinkler pump and tank are to be situated in a position reasonably remote from any machinery space of category A and are not to be situated in any space required to be protected by the sprinkler system.

9.9 System Control Requirements

9.9.1 Ready Availability

9.9.1(a) *System Readiness.* Any required automatic sprinkler, fire detection and fire alarm system are to be capable of immediate operation at all times and no action by the crew shall be necessary to set it in operation.

9.9.1(b) *System Charge.* The automatic sprinkler system is to be kept charged at the necessary pressure and shall have provision for a continuous supply of water as required in this chapter.

9.9.2 Alarm and Indication

9.9.2(a) *Automatic Alarm.* Each section of sprinklers is to include means for giving a visual and audible alarm signal automatically at one or more indicating units whenever any sprinkler comes into operation. Such alarm systems are to be such as to indicate if any fault occurs in the system. Such units are to indicate in which section served by the system a fire has occurred and are to be centralized on the navigation bridge or in the continuously-manned central control station and, in addition, visible and audible alarms from the unit are also to be placed in a position other than on the aforementioned spaces to ensure that the indication of fire is immediately received by the crew.

9.9.2(b) *Indications.* Switches are to be provided at one of the indicating positions referred to in 4-7-3/9.9.2(a) which will enable the alarm and the indicators for each section of sprinklers to be tested.

9.9.2(c) *Delivery Rates.* Sprinklers are to be placed in an overhead position and spaced in a suitable pattern to maintain an average application rate of not less than 5 l/m²/min (0.12 gal/min/ft²) over the nominal area covered by the sprinklers (i.e., gross, horizontal projection of the area to be covered). However, the ABS may permit the use of sprinklers providing such an alternative amount of water suitably distributed as has been shown to the satisfaction of the ABS to be not less effective.

9.9.2(d) *List/Plan of Covered Spaces.* A list or plan is to be displayed at each indicating unit showing the spaces covered and the location of the zone in respect of each section. Suitable instructions for testing and maintenance are to be available.

9.9.3 Testing

Means are to be provided for testing the automatic operation of the pump on reduction of pressure in the system.

11 Fixed Fire Detection and Fire Alarm Systems

11.1 Definitions

11.1.1 Section

A group of fire detectors and manually operated call points as reported in the indicating unit(s).

11.1.2 Section Identification Capability

A system with the capability of identifying the section in which a detector or manually operated call point has activated.

11.1.3 Individually Identifiable

A system with the capability to identify the exact location and type of detector or manually activated call point which has activated, and which can differentiate the signal of that device from all others.

11.3 Engineering Specifications

11.3.1 General Requirements

11.3.1(a) System Capability. Any required fixed fire detection and fire alarm system with manually operated call points is to be capable of immediate operation at all times (this does not require a backup control panel). Notwithstanding this, particular spaces may be disconnected, for example, workshops during hot work and ro-ro spaces during on and off-loading. The means for disconnecting the detectors are to be designed to automatically restore the system to normal surveillance after a predetermined time that is appropriate for the operation in question. The space is to be manned or provided with a fire patrol when detectors required by regulation are disconnected. Detectors in all other spaces are to remain operational.

11.3.1(b) System Functionality. The fire detection system is to be designed to:

- i) Control and monitor input signals from all connected fire and smoke detectors and manual call points;*
- ii) Provide output signals to the navigation bridge, continuously manned central control station or onboard safety center to notify the crew of fire and fault conditions;*
- iii) Monitor power supplies and circuits necessary for the operation of the system for loss of power and fault conditions; and*
- iv) The system may be arranged with output signals to other fire safety systems including:*
 - a) Paging systems, fire alarm or public address systems;*
 - b) Fan stops;*
 - c) Fire doors;*
 - d) Fire dampers;*
 - e) Sprinkler systems;*
 - f) Smoke extraction systems;*
 - g) Low-location lighting systems;*
 - h) Fixed local application fire-extinguishing systems;*
 - i) Closed circuit television (CCTV) systems; and*
 - j) Other fire safety systems.*

11.3.1(c) *Decision Management System.* The fire detection system may be connected to a decision management system provided that:

- i) *The decision management system is proven to be compatible with the fire detection system;*
- ii) *The decision management system can be disconnected without losing any of the functions required by 4-7-3/11 for the fire detection system; and*
- iii) *Any malfunction of the interfaced and connected equipment must not propagate under any circumstance to the fire detection system.*

11.3.1(d) *Detectors and Manual Call Points Connections.* Detectors and manual call points are to be connected to dedicated sections of the fire detection system. Other fire safety functions, such as alarm signals from the sprinkler valves, may be permitted if in separate sections.

11.3.1(e) *Environmental Design.* The system and equipment is to be suitably designed to withstand supply voltage variation and transients, ambient temperature changes, vibration, humidity, shock, impact and corrosion normally encountered in vessels. All electrical and electronic equipment on the bridge or in the vicinity of the bridge are to be tested for electromagnetic compatibility, taking into account the recommendations developed by the IMO*.

* Refer to the General requirements for electromagnetic compatibility for all electrical and electronic equipment, adopted by the IMO by resolution A.813(19).

11.3.1(f) *Individual Identification of Detectors.* Fixed fire detection and fire alarm systems with individually identifiable fire detectors are to be so arranged that:

- i) *Means are provided so that any fault (e.g., power break, short circuit, earth, etc.) occurring in the section will not prevent the continued individual identification of the remainder of the connected detectors in the section;*

A fixed fire detection and fire alarm system using individually identifiable fire detectors, is considered to be in compliance with 4-7-3/11.1.2 and 4-7-3/11.3.1(f)i) in cargo vessels and on passenger vessels cabin balconies, provided:

- a) The fixed fire detection and fire alarm system wiring loops/circuits consist of sections each containing a group of individual devices (i.e., detectors and manually operated call points, MCPs) whereby each section is so protected (e.g., by means of two short circuit fault isolator modules – one on each side of a the section) to ensure that any fault (e.g., power break short circuit, earth, etc.) occurring in the section will not prevent the continued individual identification of the remainder of the connected detectors in the other sections of the loop/circuit and of the entire fixed fire detection and alarm system per the intent of 4-7-3/11.3.1(f)i).
- b) Installation of sections is to be in accordance with 4-7-3/11.3.4. Also, the maximum number of devices within a section is to be based on good marine industry practice taking into consideration the vessel's specific arrangements.
- c) As per 4-7-3/11.3.1(g), "Section Identification Capability" is to be provided whereby the system is capable in accordance with 4-7-3/11.1.2 of identifying at the control panel the section where a failure/fault has occurred or in which a detector/MCP has activated.

Note: The above interpretation does not apply to passenger vessels (except to cabin balconies as indicated above) and is to be used until such time as a formal interpretation is issued by IACS or IMO. Approval from the vessel's flag Administration is to be obtained in advance for the implementation of the above ABS interpretation.

In this regard, since the individually identifiable fire detectors without individual short circuit isolator falls into the above interpretation, an approval from the vessel's flag Administration is required to be obtained. Otherwise, where the individually identifiable fire detectors are used, an individual short circuit isolator is to be provided for each fire detector (i.e., the individually identifiable fire detector with individual short circuit isolator).

- ii) *All arrangements are made to enable the initial configuration of the system to be restored in the event of failure (e.g., electrical, electronic, informatics, etc.);*
- iii) *The first initiated fire alarm will not prevent any other detector from initiating further fire alarms; and*
- iv) *No section will pass through a space twice. When this is not practical (e.g., for large public spaces), the part of the section which by necessity passes through the space for a second time shall be installed at the maximum possible distance from the other parts of the section.*

11.3.1(g) Activation. In passenger vessels, the fixed fire detection and fire alarm system is to be capable of remotely and individually identifying each detector and manually operated call point. Fire detectors fitted in passenger vessel cabins, when activated, are to also be capable of emitting, or cause to be emitted, an audible alarm within the space where they are located. In cargo vessels and on passenger vessel cabin balconies the fixed fire detection and fire alarm system are to, as a minimum, have section identification capability.

11.3.2 Sources of Power Supply

11.3.2(a) Number of Power Sources. There are to be not less than two sources of power supply for the electrical equipment used in the operation of the fixed fire detection and fire alarm system, one of which shall be an emergency source of power. The supply is to be provided by separate feeders reserved solely for that purpose. Such feeders are to run to an automatic changeover switch situated in or adjacent to the control panel for the fire detection system. The changeover switch is to be arranged such that a fault will not result in the loss of both power supplies. The main (respective emergency) feeder is to run from the main (respective emergency) switchboard to the change-over switch without passing through any other distributing switchboard.

11.3.2(b) Automatic Changeover. The operation of the automatic changeover switch or a failure of one of the power supplies are not to result in loss of fire detection capability. Where a momentary loss of power would cause degradation of the system, a battery of adequate capacity is to provide continuous operation during changeover.

11.3.2(c) Power Capacity. There is to be sufficient power to permit the continued operation of the system with all detectors activated, but not more than 100 if the total exceeds this figure.

11.3.2(d) Emergency Power. The emergency source of power specified in paragraph 4-7-3/11.3.2(a) above may be supplied by accumulator batteries or from the emergency switchboard. The power source is to be sufficient to maintain the operation of the fire detection and fire alarm system for the periods required by 4-8-2/5 and, at the end of that period, is to be capable of operating all connected visual and audible fire alarm signals for a period of at least 30 min.

11.3.2(e) Batteries. Where the system is supplied from accumulator batteries, they are to be located in or adjacent to the control panel for the fire detection system, or in another location suitable for use in an emergency. The rating of the battery charge unit is to be sufficient to maintain the normal output power supply to the fire detection system while recharging the batteries from a fully discharged condition.

11.3.3 Component Requirements

11.3.3(a) Detectors

- i) *Detectors are to be operated by heat, smoke or other products of combustion, flame, or any combination of these factors. Detectors operated by other factors indicative of incipient fires may be considered by ABS provided that they are no less sensitive than such detectors.*
- ii) *Smoke detectors required in all stairways, corridors and escape routes within accommodation spaces are to be certified to operate before the smoke density exceeds 12.5% obscuration per meter, but not until the smoke density exceeds 2% obscuration per meter, when tested according to standards EN 54:2001 and IEC 60092-504. Alternative testing standards may be used as determined by ABS. Smoke detectors to be installed in other spaces shall operate within sensitivity limits to the satisfaction of ABS having regard to the avoidance of detector insensitivity or oversensitivity.*

- iii) *Heat detectors are to be certified to operate before the temperature exceeds 78°C (172°F) but not until the temperature exceeds 54°C (129°F), when the temperature is raised to those limits at a rate less than 1°C per min (1.8°F per min), when tested according to standards EN 54:2001 and IEC 60092-504. Alternative testing standards may be used as determined by ABS. At higher rates of temperature rise, the heat detector is to operate within temperature limits to the satisfaction of ABS having regard to the avoidance of detector insensitivity or oversensitivity.*
- iv) *The operation temperature of heat detectors in drying rooms and similar spaces of a normal high ambient temperature may be up to 130°C (266°F), and up to 140°C (284°F) in saunas.*
- v) *Flame detectors are to be tested according to standards EN 54-10:2001 and IEC 60092-504. Alternative testing standards may be used as determined by ABS. All detectors are to be of a type such that they can be tested for correct operation and restored to normal surveillance without the renewal of any component.*
- vi) *Fixed fire detection and fire alarm systems for cabin balconies are to be approved by ABS, based on the guidelines developed by the IMO*.*
 - * *Refer to the Guidelines for approval of fixed fire detection and fire alarm systems for cabin balconies (MSC.1/Circ.1242).*
- vii) *Detectors fitted in hazardous areas are to be tested and approved for such service. Detectors required by SOLAS regulation II-2/20.4 and installed in spaces that comply with SOLAS regulation II-2/20.3.2.2 need not be suitable for hazardous areas. Detectors fitted in spaces carrying dangerous goods, required by regulation II-2/19, table 19.3, of the SOLAS to comply with regulation II-2/19.3.2 of the Convention, are to be suitable for hazardous areas.*

11.3.3(b) Control Panel. The control panel for the fire detection system is to be tested according to standards EN 54-2:1997, EN 54-4:1997 and IEC 60092-504:2001. Alternative standards may be used as determined by ABS.

11.3.3(c) Cables. Cables used in the electrical circuits are to be flame retardant according to standard IEC 60332-1-1 and -2. On passenger vessels, cables routed through other main vertical zones that they serve, and cables to control panels in an unattended fire control station are to be fire resisting according to standard IEC 60331, (See 4-8-3/9.7), unless duplicated and well separated.

11.3.4 Installation Requirements

11.3.4(a) Sections

- i) *Detectors and manually operated call points are to be grouped into sections.*
- ii) *A section of fire detectors which covers a control station, a service space or an accommodation space is not to include a machinery space of category A or a ro-ro space. A section of fire detectors which covers a ro-ro space is not to include a machinery space of category A. For fixed fire detection systems with remotely and individually identifiable fire detectors, a section covering fire detectors in accommodation, service spaces and control stations are not to include fire detectors in machinery spaces of category A or ro-ro spaces.*
- iii) *Where the fixed fire detection and fire alarm system does not include means of remotely identifying each detector individually, no section covering more than one deck within accommodation spaces, service spaces and control stations is to normally be permitted except a section which covers an enclosed stairway.*
- iv) *In order to avoid delay in identifying the source of fire, the number of enclosed spaces included in each section is to be limited as determined by the Administration. If the detection system is fitted with remotely and individually identifiable fire detectors, the sections may cover several decks and serve any number of enclosed spaces.*
- v) *In passenger vessels, a section of detectors and manually operated call points are not to be situated in more than one main vertical zone, except on cabin balconies.*

11.3.4(b) Positioning of Detectors

- i) Detectors are to be located for optimum performance. Positions near beams and ventilation ducts, or other positions where patterns of air flow could adversely affect performance, and positions where impact or physical damage is likely, shall be avoided. Detectors are to be located on the overhead at a minimum distance of 0.5 m (1.65 ft) away from bulkheads, except in corridors, lockers and stairways.
- ii) The maximum spacing of detectors shall be in accordance with the table below:

TABLE 3
Spacing of Detector

Type of detector	Maximum floor area per detector		Maximum distance apart between centers		Maximum distance away from bulkheads	
	Heat	37 m ²	398 ft ²	9 m	29.5 ft	4.5 m
Smoke	74 m ²	796 ft ²	11 m	36 ft	5.5 m	18 ft

- iii) ABS may require or permit other spacing based upon test data which demonstrate the characteristics of the detectors. Detectors located below moveable ro-ro decks are to be in accordance with the above.
- iv) Detectors in stairways are to be located at least at the top level of the stair and at every second level beneath.
- v) When fire detectors are installed in freezers, drying rooms, saunas, parts of galleys used to heat food, laundries and other spaces where steam and fumes are produced, heat detectors may be used.
- vi) Where a fixed fire detection and fire alarm system is required by 4-7-2/3, spaces having little or no fire risk need not to be fitted with detectors. Such spaces include void spaces with no storage of combustibles, private bathrooms, public toilets, fire-extinguishing medium storage rooms, cleaning gear lockers (in which flammable liquids are not stowed), open deck spaces and enclosed promenades having little or no fire risk and that are naturally ventilated by permanent openings.

11.3.4(c) Arrangement of Cables

- i) Cables which form part of the system are to be so arranged as to avoid galleys, machinery spaces of category A, and other enclosed spaces of high fire risk except where it is necessary to provide for fire detection or fire alarms in such spaces or to connect to the appropriate power supply.
- ii) A section with individually identifiable capability is to be arranged so that it cannot be damaged at more than one point by a fire.

11.5 System Control Requirements

11.5.1 Visual and Audible Fire Signals*

* Refer to the Code on Alerts and Indicators, 2009, as adopted by the IMO by resolution A.1021(26).

11.5.1(a) Manual Operation. The activation of any detector or manually operated call point is to initiate a visual and audible fire detection alarm signal at the control panel and indicating units. If the signals have not been acknowledged within 2 min, an audible fire alarm is to be automatically sounded throughout the crew accommodation and service spaces, control stations and machinery spaces of category A. This alarm sounder system need not be an integral part of the detection system.

Interpretation (IACS)

Power supply to the alarm sounder system when not an integral part of the detection system

1. The alarm sounder system utilized by the Fixed Fire Detection and Fire Alarm System shall be powered from no less than two sources of power, one of which shall be an emergency source of power.
2. In vessels required by SOLAS regulation II-1/42 or 43 to be provided with a transitional source of emergency electrical power the alarm sounder system shall also be powered from this power source.

11.5.1(b) Control Panels. In passenger vessels, the control panel is to be located in the onboard safety center. In cargo vessels, the control panel shall be located on the navigation bridge or in the fire control station.

11.5.1(c) Individual Detector Identification. In passenger vessels, an indicating unit that is capable of individually identifying each detector that has been activated or manually operated call point that has operated is to be located on the navigation bridge. In cargo vessels, an indicating unit is to be located on the navigation bridge if the control panel is located in the fire control station. In vessels with a cargo control room, an additional indicating unit is to be located in the cargo control room. In cargo vessels and on passenger cabin balconies, indicating units are to, as a minimum, denote the section in which a detector has activated or manually operated call point has operated.

11.5.1(d) Information on Covered Spaces. Clear information is to be displayed on or adjacent to each indicating unit about the spaces covered and the location of the sections.

11.5.1(e) Power Supply Monitoring. Power supplies and electric circuits necessary for the operation of the system are to be monitored for loss of power and fault conditions as appropriate including:

- i) A single open or power break fault caused by a broken wire;
- ii) A single ground fault caused by the contact of a wiring conductor to a metal component; and
- iii) A single wire to wire fault caused by the contact of two or more wiring conductors.

Occurrence of a fault condition shall initiate a visual and audible fault signal at the control panel which shall be distinct from a fire signal.

11.5.1(f) Manual Acknowledgment of Alarm. Means to manually acknowledge all alarm and fault signals are to be provided at the control panel. The audible alarm sounders on the control panel and indicating units may be manually silenced. The control panel is to be clearly distinguished between normal, alarm, acknowledged alarm, fault and silenced conditions.

11.5.1(g) Automatic Reset. The system is to be arranged to automatically reset to the normal operating condition after alarm and fault conditions are cleared.

11.5.1(h) Local Audible Alarm. When the system is required to sound a local audible alarm within the cabins where the detectors are located, a means to silence the local audible alarms from the control panel are not to be permitted.

11.5.1(i) Audible Alarm Pressure Level. In general, audible alarm sound pressure levels at the sleeping positions in the cabins and 1 m (3.3 ft) from the source is to be at least 75 dB(A) and at least 10 dB(A) above ambient noise levels existing during normal equipment operation with the ship under way in moderate weather. The sound pressure level must be in the 1/3 octave band about the fundamental frequency. Audible alarm signals are not to exceed 120 dB(A).

11.5.2 Testing

Suitable instructions and component spares for testing and maintenance are to be provided. Detectors are to be periodically tested using equipment suitable for the types of fires to which the detector is designed to respond. Detectors installed within cold spaces such as refrigerated compartments are to be tested using procedures having due regard for such locations. Vessels with self-diagnostic systems that have in place a cleaning regime for areas where heads may be prone to contamination may carry out testing in accordance with the requirements of ABS.*

* Refer to the recommendations of the International Electrotechnical Commission, in particular publication IEC 60068-2-1 – Section one -Test Ab, Environmental Testing – Part 2-1: Tests – Test A: Cold.

13 Sample Extraction Smoke Detection Systems

13.1 General Requirements

Wherever in the text of this requirement the word "system" appears, it shall mean "sample extraction smoke detection system".

13.1.1 Main Components

A sample extraction smoke detection system consists of the following main components:

13.1.1(a) *Smoke Accumulator.* Air collection devices installed at the open ends of the sampling pipes in each cargo hold that perform the physical function of collecting air samples for transmission to the control panel through the sampling pipes, and may also act as discharge nozzles for the fixed-gas fire-extinguishing system, if installed;

13.1.1(b) *Sampling Pipes.* A piping network that connects the smoke accumulators to the control panel, arranged in sections to allow the location of the fire to be readily identified;

13.1.1(c) *Three-way Valves.* If the system is interconnected to a fixed-gas fire-extinguishing system, three-way valves are used to normally align the sampling pipes to the control panel and, if a fire is detected, the three-way valves are re-aligned to connect the sampling pipes to the fire-extinguishing system discharge manifold and isolate the control panel; and

13.1.1(d) *Control Panel.* The main element of the system which provides continuous monitoring of the protected spaces for indication of smoke. It typically may include a viewing chamber or smoke sensing units. Extracted air from the protected spaces is drawn through the smoke accumulators and sampling pipes to the viewing chamber, and then to the smoke sensing chamber where the airstream is monitored by electrical smoke detectors. If smoke is sensed, the repeater panel (normally on the bridge) automatically sounds an alarm (not localized). The crew can then determine at the smoke sensing unit which cargo hold is on fire and operate the pertinent three-way valve for discharge of the extinguishing agent.

13.1.2 Continuous Operation

Any required system shall be capable of continuous operation at all times except that systems operating on a sequential scanning principle may be accepted, provided that the interval between scanning the same position twice gives a maximum allowable interval determined as follows:

The interval (I) should depend on the number of scanning points (N) and the response time of the fans (T), with a 20% allowance:

$$I = 1.2 \times T \times N$$

However, the maximum allowable interval should not exceed 120 s ($I_{\max} = 120$ s).

13.1.3 Prevention of Leakage

The system shall be designed, constructed and installed so as to prevent the leakage of any toxic or flammable substances or fire-extinguishing media into any accommodation space, service space, and control station or machinery space.

13.1.4 Environmental Design

The system and equipment shall be suitably designed to withstand supply voltage variations and transients, ambient temperature changes, vibration, humidity, shock, impact and corrosion normally encountered in ships and to avoid the possibility of ignition of a flammable gas-air mixture.

13.1.5 System Type

The system shall be of a type that can be tested for correct operation and restored to normal surveillance without the renewal of any component.

13.1.6 Alternative Power

An alternative power supply for the electrical equipment used in the operation of the system shall be provided.

13.3 Component Requirements

13.3.1 Sensing Unit

The sensing unit shall be certified to operate before the smoke density within the sensing chamber exceeds 6.65% obscuration per meter (2% obscuration per foot).

13.3.2 Extraction Fans

Duplicate sample extraction fans shall be provided. The fans shall be of sufficient capacity to operate with the normal conditions or ventilation in the protected area and the connected pipe size shall be determined with consideration of fan suction capacity and piping arrangement to satisfy the conditions of 4-7-3/13.7.2(b). Sampling pipes shall be a minimum of 12 mm (0.5 in.) internal diameter. The fan suction capacity should be adequate to ensure the response of the most remote area within the required time criteria in paragraph 4-7-3/13.7.2(b). Means to monitor airflow shall be provided in each sampling line.

13.3.3 Control Panel

The control panel shall permit observation of smoke in the individual sampling pipes.

13.3.4 Sampling Pipes

The sampling pipes shall be so designed as to ensure that, as far as practicable, equal quantities of airflow are extracted from each interconnected accumulator.

13.3.5 Periodical Purging

Sampling pipes shall be provided with an arrangement for periodically purging with compressed air.

13.3.6 Standards

The control panel for the smoke detection system shall be tested according to standards EN 54-2 (1997), EN 54-4 (1997) and IEC 60092-504 (2001). Alternative standards may be used as determined by the Administration.

13.5 Installation Requirements

13.5.1 Smoke Accumulators

13.5.1(a) Location. At least one smoke accumulator shall be located in every enclosed space for which smoke detection is required. However, where a space is designed to carry oil or refrigerated cargo alternatively with cargoes for which a smoke sampling system is required, means may be provided to isolate the smoke accumulators in such compartments for the system. Such means shall be to the satisfaction of the Administration.

13.5.1(b) Spacing. Smoke accumulators shall be located on the overhead or as high as possible in the protected space, and shall be spaced so that no part of the overhead deck area is more than 12 m (40 ft) measured horizontally from an accumulator. Where systems are used in spaces which may be mechanically ventilated, the position of the smoke accumulators shall be considered having regard to the effects of ventilation. At least one additional smoke accumulator is to be provided in the upper part of each exhaust ventilation duct. An adequate filtering system shall be fitted at the additional accumulator to avoid dust contamination.

13.5.1(c) Protecting Against Damage. Smoke accumulators shall be positioned where impact or physical damage is unlikely to occur.

13.5.1(d) Sampling Points Networks. Sampling pipe networks shall be balanced to ensure compliance with 4-7-3/13.3.4. The number of accumulators connected to each sampling pipe shall ensure compliance with 4-7-3/13.7.2(b).

13.5.1(e) Connecting to Sampling Points. Smoke accumulators from more than one enclosed space shall not be connected to the same sampling pipe.

13.5.1(f) Cargo Holds. In cargo holds where non-gastight "tween deck panels" (movable stowage platforms) are provided; smoke accumulators shall be located in both the upper and lower parts of the holds.

13.5.2 Sampling Pipes

13.5.2(a) Arrangements. The sampling pipe arrangements shall be such that the location of the fire can be readily identified.

13.5.2(b) Protections. Sampling pipes shall be self-draining and suitably protected from impact or damage from cargo working.

13.7 System Control Requirements

13.7.1 Visual and Audible Fire Signals

13.7.1(a) General. The detection of smoke or other products of combustion shall initiate a visual and audible signal at the control panel and indicating units.

13.7.1(b) Location. The control panel shall be located on the navigation bridge or in the fire control station. An indicating unit shall be located on the navigation bridge if the control panel is located in the fire control station.

Where the CO₂ system discharge piping is also used for the sample extraction smoke detection system piping, the control panel can be located in the CO₂ room provided that an indicating unit is located on the navigation bridge. [Refer to IMO MSC.1/Circ. 1487].

13.7.1(c) Display. Clear information shall be displayed on or adjacent to the control panel and indicating units designating the spaces covered.

13.7.1(d) Power Supply. Power supplies necessary for the operation of the system shall be monitored for loss of power. Any loss of power shall initiate a visual and audible signal at the control panel and the navigating bridge which shall be distinct from a signal indicating smoke detection.

13.7.1(e) Manual Acknowledgment. Means to manually acknowledge all alarm and fault signals shall be provided at the control panel. The audible alarm sounders on the control panel and indicating units may be manually silenced. The control panel shall clearly distinguish between normal, alarm, acknowledged alarm, fault and silenced conditions.

13.7.1(f) Automatic Reset. The system shall be arranged to automatically reset to the normal operating condition after alarm and fault conditions are cleared.

13.7.2 Testing

13.7.2(a) Instruction and Spares. Suitable instructions and component spares shall be provided for the testing and maintenance of the system.

13.7.2(b) Functional Test. After installation, the system shall be functionally tested using smoke generating machines or equivalent as a smoke source. An alarm shall be received at the control unit in not more than 180 s for vehicle decks, and not more than 300 s for container and general cargo holds, after smoke is introduced at the most remote accumulator."

15 Miscellaneous Fire Fighting Equipment

15.1 Portable Fire Extinguishers

15.1.1 Type and Capacity

All fire extinguishers are to be of approved types and designs. Each powder or carbon dioxide extinguisher is to have a capacity of at least 5 kg (11 lb.), and each foam extinguisher is to have a capacity of at least 9 liters (2.5 gallons). The mass of a portable fire extinguisher is not to exceed 23 kg (50.7 lb), and each is to have a fire extinguishing capability at least equivalent to that of a 9 liter (2.5 gallon) fluid extinguisher. 4-7-3/Table 4 may be used to determine the equivalents of portable fire extinguishers:

TABLE 4
Equivalent Fire Extinguishers

Classification		Water		Foam		CO ₂		Dry chemical	
Type	Size	liters	gallons	liters	gallons	kg	lb	kg	lb
A	II	9	2.5	9	2.5	---	---	5 ⁽¹⁾	11 ⁽¹⁾
B	II			9	2.5	5.0	11	5	11
B	III			45	12	15.8	35	9	20
B	V			152	40	45	100	22.5 ⁽²⁾	50 ⁽²⁾
C	I					1.8	4	0.9	2
C	II					5.0	11	5	11

Type A: Suitable for use on fires involving ordinary combustible materials such as wood, cloth, paper and textiles

Type B: Suitable for use on fires involving flammable and combustible liquids (e.g. oils, oil based paints, solvents, petroleum greases, etc.)

Type C: Suitable for use on fires involving energized electrical equipment where electrical non-conductivity of the extinguishing medium is important

Note:

- 1 Must be specifically approved as Type A, B, C extinguisher.
- 2 For outside use, double the amount to be carried, unless specifically stated such as for helideck.

Fire extinguishers containing an extinguishing medium which, either by itself or under expected conditions of use, gives off toxic gases in such quantities as to endanger persons are not permitted.

15.1.2 Spare Charges

Spare charge is to be provided for 100% of the first 10 extinguishers and 50% of the remaining fire extinguishers capable of being recharged onboard. Not more than 60 total spare charges are required. Instructions for recharging are to be carried onboard. Only refills approved for the fire extinguisher in question is to be used for recharging.

For fire extinguishers which cannot be recharged onboard, additional portable fire extinguishers of the same quantity, type, capacity and number, as determined above, are to be provided in lieu of spare charges.

15.1.3 Installation

See Section 4-7-2, 5C-5-7/Table 2 and 5C-5-7/Table 3 (container carriers), 5C-9-11/3.14 (chemical carriers) and 5C-10-4/3.3.3 (ro-ro vessels) regarding the type, size, quantity and locations of portable fire extinguishers required. Also, one of the portable fire extinguishers intended for use in any space is to be stowed near the entrance to that space or as indicated in 4-7-3/Table 5.

The selection of portable fire extinguishers is to be appropriate to the fire hazard(s) in the space in accordance with the Guidelines for marine portable fire extinguishers, as adopted by Resolution A.951(23). For installation, refer to MSC.1/Circ.1275 "Unified Interpretation of SOLAS Chapter II-2 on the Number and Arrangement of Portable Fire Extinguishers on Board Ships".

15.1.4 Arrangements

Carbon dioxide fire extinguishers are not to be placed in accommodation spaces. In control stations and other spaces containing electrical or electronic equipment or appliances necessary for the safety of the vessel, fire extinguishers are to be provided whose extinguishing media are neither electrically conductive nor harmful to the equipment and appliances.

TABLE 5
Portable and Semi-portable Extinguishers

<i>Space</i>	<i>Classification</i>	<i>Quantity and Location</i> ⁽⁵⁾
Safety Areas		
Communicating corridors	A-II	1 in each main corridor not more than 46 m (150 ft) apart. (May be located in stairways.)
Pilothouse	C-II	2 in vicinity of exit. See Notes 4 and 6.
Radio room	C-II	1 in vicinity of exit. See Note 4.
Accommodations		
Sleeping Accommodations	A-II	1 in each sleeping accommodation space. (Where occupied by more than four persons.)
Service Spaces		
Galleys	B-II or C-II	1 for each 230 m ² (2500 ft ²) or fraction thereof for hazards involved.
Storerooms	A-II	1 for each 230m ² (2500 ft ²) or fraction thereof located in vicinity of exits, either inside or outside of spaces. See Note 4.
Workshops	A-II	1 outside the space in vicinity of exit. See Note 4.
Machinery Spaces		
Internal combustion or gas turbine-engines	B-II and B-III	1 for each 746 kW (1000 hp), but not less than 2 nor more than 6. See Note 1. 1 required. See Note 3.
Electric motors or generators of the open type	C-II	1 for each motor or generator unit. See Note 2.

Notes:

- 1 When installation is on weather deck or open to atmosphere at all times, one B-II for every three engines is allowable.
- 2 Small electrical appliances, such as fans, etc., are not to be counted or used as basis for determining number of extinguishers required.
- 3 Not required on vessels of less than 500 gross tons.
- 4 Vicinity means within 1 m (3 ft).
- 5 For vessels of 1000 gross tons and above, at least five extinguishers are to be provided for accommodation spaces, service spaces, spaces where the vessel's radio, main navigation equipment or emergency source of power is located, and locations where the fire recording or fire control equipment is located.
- 6 For cargo ships less than 500 gross tons, "C-I" portable extinguishers may be used.

15.3 Portable Foam Applicators

15.3.1 Specification

A portable foam applicator unit is to consist of a foam nozzle/branch pipe, either of a self-inducing type or in combination with a separate inductor, capable of being connected to the fire main by a fire hose, together with a portable tank containing at least 20 liters (5.3 US gal.) of foam concentrate and at least one spare tank of foam concentrate of the same capacity.

15.3.2 System Performance

- i) *The nozzle/branch pipe and inductor are to be capable of producing effective foam suitable for extinguishing an oil fire, at a foam solution flow rate of at least 200 l/min (52.8 gpm) at the nominal pressure in the fire main.*
- ii) *The foam concentrate shall be approved by ABS based on the Guidelines for the Performance and Testing Criteria and Surveys of Low-expansion Foam Concentrates for Fixed Fire-extinguishing Systems (MSC/Circ.582/Corr.1).*
- iii) *The values of the foam expansion and drainage time of the foam produced by the portable foam applicator unit are not to differ more than ±10% of that determined in 4-7-3/15.3.2.ii).*
- iv) *The portable foam applicator unit is to be designed to withstand clogging, ambient temperature changes, vibration, humidity, shock, impact and corrosion normally encountered on ships.*

15.5 Fire-fighter's Outfit

15.5.1 Constituents of the Outfit

A fire-fighter's outfit is to consist of a set of personal equipment and a breathing apparatus:

15.5.1(a) *Personal equipment.* Personal equipment is to consist of:

- Protective clothing of material to protect the skin from the heat radiating from the fire and from burns and scalding by steam. The outer surface is to be water-resistant.
- Boots of rubber or other electrically non-conducting material.
- A rigid helmet providing effective protection against impact.
- An electric safety lamp (hand lantern) of an approved type with a minimum burning period of three hours. Electric safety lamps on a tanker and those intended to be used in hazardous areas are to be of an explosion-proof type; and
- An axe with a handle provided with high-voltage insulation.

15.5.1(b) *Breathing apparatus.* Breathing apparatus is to be a self-contained compressed air-operated breathing apparatus, the volume of the air contained in the cylinders of which is to be at least 1,200 liters (317 gal.), or other self-contained breathing apparatus which is to be capable of functioning for at least 30 min. Compressed air breathing apparatus shall be fitted with an audible alarm and a visual or other device which will alert the user before the volume of the air in the cylinder has been reduced to no less than 200 liters (53 gal.). Two spare charges are to be provided for each required breathing apparatus. All air cylinders for breathing apparatus are to be interchangeable. Vessels that are equipped with suitably located means for fully recharging the air cylinders free from contamination need carry only one spare charge for each required apparatus.

15.5.1(c) *Lifeline.* For each breathing apparatus, a fireproof lifeline of at least 30 m (98.5 ft) in length is to be provided. The lifeline is to successfully pass an approval test by static load of 3.5 kN (360 kgf, 787 lbf) for 5 min. without failure. The lifeline is to be capable of being attached by means of a snap hook to the harness of the apparatus or to a separate belt in order to prevent the breathing apparatus becoming detached when the lifeline is operated.

15.5.2 Two-way Portable Radiotelephone

A minimum of two two-way portable radiotelephone apparatus for each fire party for fire-fighter's communication shall be carried on board. Those two-way portable radiotelephone apparatus shall be of an explosion-proof type or intrinsically safe.

15.5.3 Required Number of Fire-fighter's Outfits

15.5.3(a) *Minimum number of fire-fighter's outfits.* All vessels are to carry at least two fire-fighter's outfits, complying with the requirements of 4-7-3/15.5.1.

15.5.3(b) *Additional fire-fighter's outfits.* Additional sets of personal equipment and breathing apparatus may be required, having due regard to the size and type of the vessel.

15.5.4 Storage of Fire-fighter's Outfits

The fire-fighter's outfits or sets of personal equipment are to be kept ready for use in an easily accessible location that is permanently and clearly marked and, where more than one fire-fighter's outfit or more than one set of personal equipment is carried, they are to be stored in widely separated positions.

15.7 Emergency Escape Breathing Devices (EEBDs)

15.7.1 Accommodation Spaces

All ships are to carry at least two emergency escape breathing devices and one spare device within accommodation spaces.

15.7.2 Machinery Spaces

On all vessels, within the machinery spaces, emergency escape breathing devices are to be situated ready for use at easily visible places, which can be reached quickly and easily at any time in the event of fire. The location of emergency escape breathing devices is to take into account the layout of the machinery space and the number of persons normally working in the spaces. (See the Guidelines for the performance, location, use and care of emergency escape breathing devices, MSC/Circ. 849 and 1081). The number and locations of EEBDs are to be indicated in the fire control plan required in 4-7-1/9.

A summary of the MSC/Circ. 1081 requirements are shown in 4-7-3/Table 6. This applies to machinery spaces where crew are normally employed or may be present on a routine basis.

TABLE 6
Minimum Number of Required EEBDs

A. In machinery spaces for category A containing internal combustion machinery used for main propulsion⁽¹⁾:
a) One (1) EEBD in the engine control room, if located within the machinery space
b) One (1) EEBD in workshop areas. If there is, however, a direct access to an escape way from the workshop, an EEBD is not required; and
c) One (1) EEBD on each deck or platform level near the escape ladder constituting the second means of escape from the machinery space (the other means being an enclosed escape trunk or watertight door at the lower level of the space).
B. In machinery spaces of category A other than those containing internal combustion machinery used for main propulsion,
One (1) EEBD should, as a minimum, be provided on each deck or platform level near the escape ladder constituting the second means of escape from the space (the other means being an enclosed escape trunk or watertight door at the lower level of the space).
C. In other machinery spaces
The number and location of EEBDs are to be determined by the Flag Administration.

Note:

- 1 Alternatively, a different number or location may be determined by the Flag Administration taking into consideration the layout and dimensions or the normal manning of the space.

15.7.3 EEBD Specification

15.7.3(a) General. An EEBD is a supply-air or oxygen device only used for escape from a compartment that has a hazardous atmosphere and is to be of an approved type. EEBDs are not to be used for fighting fires, entering oxygen deficient voids or tanks, or worn by fire-fighters. In these events, a self-containing breathing apparatus, which is specifically suited for such applications, is to be used.

15.7.3(b) EEBD Particulars. The EEBD is to have duration of service for 10 minutes. The EEBD is to include a hood or full face piece, as appropriate, to protect the eyes, nose and mouth during escape. Hoods and face pieces are to be constructed of flame resistant materials and include a clear window for viewing. An inactivated EEBD is to be capable of being carried hands-free.

15.7.3(c) EEBD Storage. An EEBD, when stored, is to be suitably protected from the environment.

15.7.3(d) EEBD Instructions and Markings. Brief instructions or diagrams clearly illustrating their use are to be clearly printed on the EEBD. The donning procedures are to be quick and easy, to allow for situations where there is little time to seek safety from a hazardous atmosphere. Maintenance requirements, manufacturer's trademarks and serial number, shelf life with accompanying manufacture date and name of approving authority are to be printed on each EEBD. All EEBD training units are to be clearly marked.

PART

4

CHAPTER 7 Fire Extinguishing Systems

SECTION 4 Requirements for Vessels Under 500 Gross Tons

1 General

Plans and specifications to be submitted are noted in 4-7-1/7.

3 Fire Pumps

3.1 Number of Pumps

All vessels are to have at least two fire pumps. Only one of the pumps need be independently power-driven, and one of the pumps may be attached to the propulsion unit. For vessels less than 20 m (65 ft) in length, one power-driven pump, which may be an attached unit, and one hand operated fire pump may be provided.

3.3 Capacity

The capacity of each power-driven fire pump is to be in accordance with the 4-7-4/Table 1. Hand pumps, where permitted, are to have a minimum capacity of 1.1 m³/hr (5 gpm).

5 Fixed Fire Extinguishing Systems

5.1 Fixed Systems

For all vessels, fixed fire extinguishing systems are to be fitted in the machinery spaces when propulsion and auxiliary engines with a total aggregate power of 750 kW (1000 bhp) or greater are installed (see 4-7-1/11.13) in any machinery space in which an oil fuel unit for heated fuel oil is installed, regardless of the total aggregate power.

5.3 Portable Extinguishers

Portable fire extinguishers are to be provided in the quantities and locations indicated in 4-7-3/Table 5.

7 Carbon Dioxide Systems

Where a fixed carbon dioxide fire extinguishing system is installed, the system is to comply with the requirements of 4-7-3/3.1 and 4-7-3/3.3 or 4-7-3/3.5, except that storage arrangements may be in accordance with the following.

7.1 Storage

Generally, the cylinders are to be located outside of the protected space in a room which is situated in a safe and readily accessible location. The access doors to the storage space are to open outwards. The storage room is to be gastight and effectively ventilated. The ventilation system is to be independent of the protected space. Any entrance to the storage room is to be independent of the protected space, except that where this is impracticable due to space limitations, the following requirements may be considered:

- i) The door between the storage location and the protected space is to be self-closing with no hold-back arrangements.
- ii) The space where cylinders are stored is to be adequately ventilated by a system which is independent of the protected space.
- iii) Means are to be provided to prevent unauthorized release of gas, such as containment behind a break glass.
- iv) There is to be provision to vent the bottles to the atmosphere in order to prevent a hazard to personnel occupying the storage area.
- v) An additional entrance to the storage location, independent of the protected space, is provided.

9 Axe

One fire axe is to be provided on each vessel 20 m (65 ft) in length and over.

11 Vessels Intended to Carry Oil in Bulk

11.1 Cargo Pump Rooms

Cargo pump rooms are to be provided with an approved fixed fire extinguishing system controlled from the deck.

11.3 Cargo Tank Protection

For tankers of 30.5 m (100 ft) in length and above, a deck foam system is to be installed for the protection of all cargo tanks. For tankers less than 30.5 m (100 ft) in length, two B-V extinguishers (see 4-7-3/Table 4) are to be provided for the protection of the cargo tanks.

TABLE 1
Fire Pump Minimum Capacity for Vessels Less Than 500 Gross Tons

<i>Vessel Length</i>	<i>Minimum Capacity</i>
Less than 20 m (65 ft)	5.50 m ³ /hr (25 gpm)
20 m (65 ft) or greater but less than 30.5 m (100 ft)	11.0 m ³ /hr (50 gpm)
30.5 m (100 ft) or greater but less than 61 m (200 ft)	14.3 m ³ /hr (66.6 gpm)
61 m (200 ft) or greater	Capacity to be in accordance with 4-7-3/1.3

4

CHAPTER 8 Electrical Systems

CONTENTS

SECTION 1	General Provisions.....	633
1	Organization of Requirements for Electrical Systems	633
3	Applications.....	633
5	Plans and Data to be Submitted	634
5.1	System Plans.....	634
5.3	Installation Plans.....	636
5.5	Equipment Plans.....	637
7	Definitions	637
7.1	General.....	637
7.3	Specific.....	638
9	Basic Requirements.....	639
TABLE 1	Primary Essential Services	640
TABLE 2	Secondary Essential Services	640
SECTION 2	System Design.....	641
1	Applications.....	641
3	Main Source of Electrical Power	641
3.1	Number and Capacity of Generators	641
3.3	Power Supplied by Propulsion Generators	642
3.5	Generators Driven by Propulsion Machinery	642
3.7	Transformers and Converters	643
3.9	Location of Generators	643
3.11	System Arrangement.....	643
3.13	Main Switchboard	644
5	Emergency Source of Electrical Power	644
5.1	General.....	644
5.3	Location	644
5.5	Emergency Services.....	646
5.7	Vessels on Short Duration Voyages	648
5.9	Power Source	648
5.11	Transitional Source of Power.....	649
5.13	Emergency Switchboard.....	649
5.15	Starting Arrangements for Emergency Generator Sets	650
5.17	Use of Emergency Generator in Port (for Vessels 500 GT and Over).....	651
5.19	Alarms and Safeguards for Emergency Diesel Engines	651
5.21	Vessels Less than 500 GT Having Electrical Plants of 75 kW and Above	652

7	Distribution System	653
7.1	General.....	653
7.3	Hull Return Systems.....	653
7.5	Earthed AC Distribution System	653
7.7	Cable Sizing	654
7.9	Segregation of Power Circuits	655
7.11	Steering Gear Power Supply Feeders	655
7.13	Lighting System.....	656
7.15	Ventilation System Circuits.....	656
7.17	Cargo Space Circuits	656
7.19	Electric Space Heater Circuits.....	656
7.21	Harmonics	656
9	System Protection.....	657
9.1	General.....	657
9.3	Protection Against Short Circuit.....	657
9.5	Protection Against Overload.....	658
9.7	Coordination of Protective Devices	658
9.9	Load Shedding Arrangements.....	658
9.11	Protection of Generators	659
9.13	Protection of Feeder Cables.....	660
9.15	Protection for Accumulator Batteries	660
9.17	Protection of Motor Circuits	660
9.19	Protection of Transformer Circuits.....	662
9.21	Protection for Branch Lighting Circuits	662
9.22	Harmonic Distortion for Ship Electrical Distribution System including Harmonic Filters	662
9.23	Protection of Harmonic Filter Circuits Associated with Electric Propulsion	663
11	Specific Systems.....	663
11.1	Shore Connection.....	663
11.3	Navigation Light System.....	664
11.5	Interior Communication Systems.....	665
11.7	Manually Operated Alarms	666
11.9	Emergency Shutdown Systems.....	667
11.11	Battery Starting Systems.....	668
TABLE 1	Services to be Powered by an Emergency Source and by a Transitional Source	647
TABLE 2	Alarms and Safeguards for Emergency Diesel Engines.....	652
FIGURE 1	Cofferdam with Extension Beyond the Boundaries of the Space Containing the Emergency Source.....	645
FIGURE 2	Cofferdam without Extension Beyond the Boundaries of the Space Containing the Emergency Source.....	645
FIGURE 3	Boundary Insulated to A-60 with the Insulation Extending Beyond the Boundaries of the Space Containing the Emergency Source	646

SECTION 3	Electrical Equipment	669
1	General	669
	1.1 Application	669
	1.3 Standard of Compliance	669
	1.5 Certification of Equipment	669
	1.7 Materials and Design	670
	1.9 Voltage and Frequency Variations	670
	1.11 Enclosures	670
	1.13 Accessibility	671
	1.15 Insulation Material	672
	1.17 Ambient Temperatures	672
3	Rotating Machines	673
	3.1 Application	673
	3.3 Definitions	673
	3.5 Rating	673
	3.7 Overload/Overcurrent Capability	673
	3.9 Short-circuit Capability	674
	3.11 Construction	674
	3.13 Generator Control	675
	3.15 Testing	677
	3.17 Certification	680
5	Switchboards, Motor Controllers, etc.	680
	5.1 Application	680
	5.3 Construction, Assembly and Components	680
	5.5 Main and Emergency Switchboards	682
	5.7 Motor Controllers	683
	5.9 Battery Systems and Uninterruptible Power Systems (UPS)	683
	5.11 Testing and Certification	685
7	Transformers	686
	7.1 Enclosures	686
	7.3 Transformers for Essential Services	686
8	Semiconductor Converters for Adjustable Speed Motor Drives	688
	8.1 Application	688
	8.3 Standards of Compliance	688
	8.5 Design, Construction and Assembly Requirements	688
	8.7 Inspection and Testing	692
	8.9 Integration Requirements	695
9	Cables	695
	9.1 Standard of Compliance	695
	9.3 Current Carrying Capacity	695
	9.4 Minimum Cable Conductor Size	696
	9.5 Flame Retardant Standard	696
	9.7 Fire Resistant Standard	696
	9.9 Insulation Temperature Rating	696
	9.11 Armor for Single Core Cables	696
	9.13 Fiber Optic Cables	696
	9.15 Mineral-insulated Metal-sheathed Cables	697

9.17	Test and Certification	697
9.19	Cable Splices	697
9.21	Cable Junction Boxes.....	697
11	Non-sparking Fans.....	697
11.1	Design	697
11.3	Materials.....	697
11.5	Type Test	698
13	Certified Safe Equipment.....	698
13.1	General.....	698
13.3	Acceptable Types of Certified Safe Equipment	698
13.5	Flammable Gas Groups and Temperature Classes	699
15	Computer-based Systems	699
TABLE 1A	Degree of Protection of Electrical Equipment (First IP Numeral).....	700
TABLE 1B	Degree of Protection of Electrical Equipment (Second IP Numeral)	700
TABLE 2	Minimum Degree of Protection	701
TABLE 3	Factory Test Schedule for Generators and Motors ≥ 100 kW (135 hp).....	702
TABLE 4	Limit of Temperature Rise for Air Cooled Rotating Machines.....	703
TABLE 5	Equipment and Instrumentation for Switchboards.....	704
TABLE 6	Maximum Current Carrying Capacity for Cables	706
TABLE 7	Additional Services Requiring Electrical Equipment to be Designed, Constructed and Tested to the Requirements in Section 4-8-3.....	708
FIGURE 1	Example of Area Affected by Local Fixed Pressure Water- spraying or Local Water-mist Fire Extinguishing System in Machinery Spaces	671

SECTION 4 Shipboard Installation and Tests..... 709

1	General	709
1.1	Application.....	709
1.3	Degree of Enclosure.....	709
1.5	Hazardous Areas.....	709
1.7	Inclination	709
1.9	Services Required to be Operable Under a Fire Condition.....	709
1.11	High Fire Risk Areas	710
1.13	Installation Requirements for Recovery from Dead Ship Condition	710
3	Generators and Motors	710
5	Accumulator Batteries.....	710
5.1	General.....	710
5.3	Lead-acid or Alkaline Battery Storage Locations.....	712
5.5	Low-hydrogen-emission Battery Storage Locations	713

7	Switchboard and Distribution Boards.....	713
7.1	Switchboard.....	713
7.3	Distribution Boards	714
9	Motor Controllers and Motor Control Centers.....	714
9.1	Location	714
9.3	Disconnecting Arrangements.....	714
9.5	Resistors for Control Apparatus.....	715
11	Lighting Systems.....	715
11.1	General.....	715
11.3	Lighting Installation in Cargo Spaces.....	715
11.5	Lighting Distribution Boards	715
13	Heating Equipment	715
13.1	Electric Radiators.....	715
15	Magnetic Compasses	715
17	Portable Equipment and Outlets	715
19	Power Receptacles	716
21	Cable Installation	716
21.1	General Requirements.....	716
21.3	Cable Current Carrying Capacity	717
21.5	Cable Voltage Drop	717
21.7	Protection for Electric-magnetic Induction	717
21.9	Cable Support.....	718
21.11	Cable Bending Radii	719
21.13	Deck and Bulkhead Penetrations	720
21.15	Mechanical Protection for Cables	720
21.17	Installation of Cables and Apparatus for Emergency and Essential Services	721
21.19	Mineral Insulated Cables	721
21.21	Fiber Optic Cables	722
21.23	Installation of Cable Splices.....	722
21.25	Installation of Cable Junction Boxes	722
21.27	Cable Termination	722
23	Equipment Earthing	723
23.1	General Requirements.....	723
23.3	Earthing Methods.....	723
23.5	Lightning Earth Conductors	723
25	System Earthing.....	723
27	Electrical Equipment in Hazardous Areas	724
27.1	General.....	724
27.3	Hazardous Areas	725
27.5	Certified Safe Equipment in Hazardous Areas	726
27.7	Intrinsically Safe Systems.....	727
27.9	Cables in Hazardous Areas	728
27.11	Lighting Circuits in Hazardous Areas.....	728
27.13	Permanent Notice and Booklet of Certified Safe Equipment	728

29	Shipboard Tests.....	728
29.1	General.....	728
29.3	Generators	728
29.5	Switchboards.....	728
29.7	Motors	728
29.9	Interior Communications System.....	728
29.11	Voltage Drop Measurement.....	728
29.13	Insulation Resistance Measurements.....	729
29.15	Watertight and Fire-rated Deck and Bulkhead Cable Penetrations	729
31	Guidance for Spare Parts	729
31.1	Spare Parts of Electrical Equipment.....	729
31.3	Measuring Instrument.....	729

TABLE 1	Size of Earthing Conductors (Equipment and System Earthing).....	724
---------	--	-----

FIGURE 1	Cables within High Fire Risk Areas.....	721
----------	---	-----

SECTION 4 Appendix 1 –Type Test Procedure for Plastic Cable Tray and Protective Casing..... 730

1	General	730
3	General Design Requirements	730
3.1	Ambient Temperatures	730
3.3	Test Temperature.....	730
3.5	Safe Working Load.....	731
5	Mechanical Requirements	731
5.1	Impact Resistance Test.....	731
5.3	Safe Working Load (SWL) Test.....	731
7	Fire Properties	732
7.1	Flame Retardant Test.....	732
7.3	Smoke and Toxicity Test.....	733
9	Electrical Properties	733
9.1	Resistivity Test	733

FIGURE 1	SWL Loading Test Procedure.....	732
----------	---------------------------------	-----

SECTION 5 Special Systems..... 734

1	Application	734
3	High Voltage Systems.....	734
3.1	Application.....	734
3.3	System Design	734
3.5	Circuit Protection	735
3.7	Equipment Design	736
3.9	Cable Installation.....	740
3.10	High Voltage Shore Connection (HVSC).....	741
3.11	Equipment Installation	741

	3.13	Tests.....	742
	3.15	Design Operating Philosophy	742
	3.17	Preliminary Operations Manual	744
5		Electric Propulsion Systems	745
	5.1	General.....	745
	5.3	System Design	745
	5.5	Electric Power Supply Systems	747
	5.7	Circuit Protection	747
	5.9	Protection for Earth Leakage	748
	5.11	Propulsion Control	748
	5.13	Instrumentation at the Control Station	749
	5.15	Equipment Installation and Arrangements	750
	5.17	Equipment Requirements	750
	5.19	Trials.....	753
7		Three-wire Dual-voltage DC Systems	753
	7.1	Three-wire DC Generators	753
	7.3	Neutral Earthing.....	753
9		Electrical Plants of Less Than 75 kW	754
	9.1	General.....	754
	9.3	Standard Details	754
	9.5	Calculations of Short-circuit Currents	754
	9.7	Lightning Protection	754
	9.9	Temperature Ratings.....	754
	9.11	Generators.....	755
	9.13	Emergency Source of Power	755
	9.15	Cable Construction	755
	9.17	Switchboards, Distribution Boards and Panels	755
	9.19	Navigation Running Lights.....	755
TABLE 1		High Voltage Equipment Locations and Minimum Degree of Protection	756

4

CHAPTER 8 Electrical Systems

SECTION 1 General Provisions

1 Organization of Requirements for Electrical Systems

The requirements for electrical systems are organized, as follows:

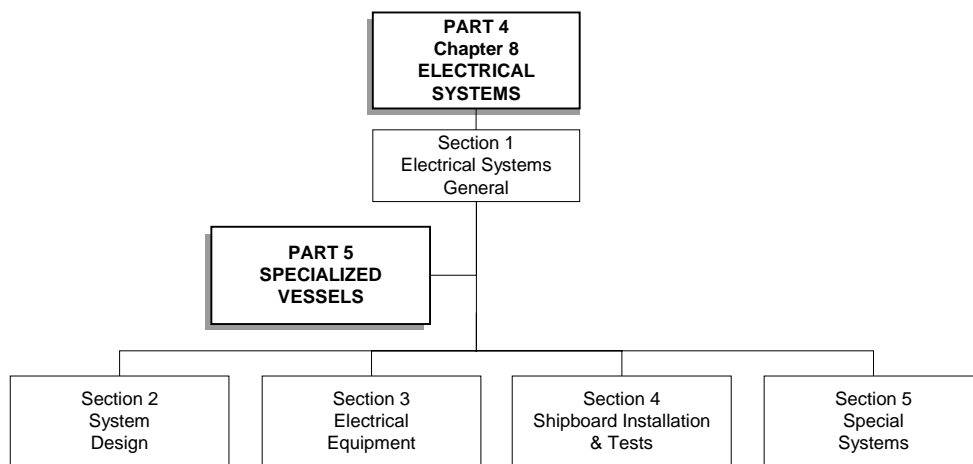

Section 4-8-1 deals with general issues and provides, for example, the required submittals and definitions for terms used throughout the electrical systems sections. Section 4-8-2, Section 4-8-3 and Section 4-8-4 provide for system design, equipment design and tests, and shipboard installation and tests. Section 4-8-5 provides special requirements for system design, equipment and installation of high voltage systems and electric propulsion systems. Requirements applicable to specific types of vessels are provided separately in Part 5C and Part 5D of the Rules.

3 Applications

Electrical systems and equipment of unrestricted ocean-going vessels are to be designed, constructed, installed and tested in accordance with applicable requirements of Section 4-8-1, Section 4-8-2, Section 4-8-3 and Section 4-8-4. Additional requirements for special systems, namely, high voltage systems (see definition in 4-8-1/7.3) and electric propulsion systems, are provided in Section 4-8-5. Requirements applicable to specialized vessel types, such as oil carriers, vehicle carriers, etc., are provided in Part 5C and Part 5D of the Rules.

Arrangements and details that can be shown to comply with other recognized standards that are not less effective than the Rules may be considered, see 4-1-1/1.7.

5 Plans and Data to be Submitted

5.1 System Plans

The following plans and data are to be submitted.

Plans should generally be submitted electronically to ABS. However hard copies will also be accepted.

5.1.1 One Line Diagram

One line diagram of main and emergency power distribution systems to show:

- *Generators*: kW rating, voltage, rated current, frequency, number of phases, power factor.
- *Motors*: kW or hp rating, voltage and current rating, remote stops (when required).
- *Motor controllers*: type (direct-on-line, star-delta, etc.), disconnect devices, overload and undervoltage protections, remote stops, as applicable.
- *Transformers*: kVA rating, rated voltage and current, winding connection.
- *Circuits*: designations, type and size of cables, trip setting and rating of circuit protective devices, rated load of each branch circuit, emergency tripping and preferential tripping features.
- *Batteries*: type, voltage, rated capacity, conductor protection, charging and discharging boards.

5.1.2 Schematic Diagrams

Schematic diagrams for the following systems are to be submitted. Each circuit in the diagrams is to indicate type and size of cable, trip setting and rating of circuit protective device, and rated capacity of the connected load.

- General lighting, normal and emergency
- Navigation lights
- Interior communications
- General emergency alarm
- Intrinsically safe systems
- Emergency generator starting
- Steering gear system
- Fire detection and alarm system
- Inert gas control, monitoring and alarm

5.1.3 Short-circuit Data

- Maximum calculated short-circuit current values, both symmetrical and asymmetrical values, available at the main and emergency switchboards and the downstream distribution boards.
- Rated breaking and making capacities of the protective devices.

Reference may be made to IEC Publication 61363-1 Electrical Installations of Ships and Mobile and Fixed Offshore Units – Part 1: Procedures for Calculating Short-Circuit Currents in Three-Phase A.C.

5.1.4 Protective Device Coordination Study

This is to be an organized time-current study of all protective devices, taken in series, from the utilization equipment to the source, under various conditions of short circuit. The time-current study is to indicate settings of long-time delay tripping, short-time delay tripping, and instantaneous tripping, as applicable. Where an overcurrent relay is provided in series and adjacent to the circuit protective devices, the operating and time-current characteristics of the relay are to be considered for coordination. Typical thermal withstanding capacity curves of the generators are to be included, as appropriate.

5.1.5 Load Analysis

An electric-plant load analysis is to cover all operating conditions of the vessel, such as conditions in normal sea going, cargo handling, harbor maneuver and emergency operations.

The analyses are to include:

- The simultaneous operation of loads on the emergency switchboard as per 4-8-2/5.5. Where the emergency generator capacity is less than the sum of all of the nameplate rated loads, which can be simultaneously connected to the emergency switchboard, then the analysis is to be supported by a justification for each reduced or non-simultaneous load used.
- High voltage ship service transformers or converters, where applicable per 4-8-2/3.7
- Identifying the loads to be tripped to ensure continuity of supply per 4-8-2/3.5.2iv), 4-8-2/3.11.1, 4-8-2/9.1, 4-8-2/9.9.

5.1.6 Other Information

A description of the power management system, including equipment fitted with preferential trips, schedule of sequential start of motors, etc., as applicable.

Voltage-drop for the longest run of each cable size for vessels having a length of 61 m (200 ft) and over.

Maintenance schedule of batteries for essential and emergency services. See 4-8-4/5.1.5.

Plans showing details and arrangements of oil mist detection/monitoring and alarm arrangements. See 4-2-1/7.2.2(c)viii).

Information on alarms and safeguards for emergency diesel engines. See 4-8-2/5.19.1.

5.1.7 High Voltage Systems

5.1.7(a) *Documents*. High Voltage Design Operating Philosophy Document (See 4-8-5/3.15)

5.1.7(b) *Analysis*. Arc-flash hazard analyses [See 4-8-5/3.7.4(e)]

5.1.7(c) *Operating Manual*. Preliminary Operation Manual for the high voltage system and equipment (See 4-8-5/3.17)

5.1.7(d) *General Arrangement*. General Arrangement of the switchboards and distribution boards

5.1.7(e) *Spaces*. General Arrangement of spaces containing high voltage switchboards showing the location of:

- i) Access and operating locations
- ii) The equipment in 4-8-1/5.1.7(d) above, with equipment access doors closed, open, maximum extent of withdrawable circuit breakers and associated cradles/dollies
- iii) Doors to the room
- iv) Location of work areas associated with the activities described in 4-8-5/3.15.3
- v) Location and inventory of personal protective equipment (PPE) and safety equipment
- vi) First aid equipment

5.1.7(f) *Analysis and Data.* An analysis or data for the estimated voltage transients to show that the insulation of power transformers is capable of withstanding the estimated voltage transients.

5.1.7(g) *Standards.* The applicable standard of construction and the rated withstand voltage of the insulation for power transformers. (This information is in addition to the information required in 4-8-3/7)

5.3 Installation Plans

The following plans and data, as applicable, are to be submitted for approval before proceeding with the work.

Plans should generally be submitted electronically to ABS. However hard copies will also be accepted.

5.3.1 Booklet of Standard Wiring Practice

This is to contain standard wiring practices and installation details. They are to include, but not limited to, cable supports and retention, typical radii of cable bends, bulkhead and deck penetrations, cable joints and sealing, cable splicing, earthing details, watertight and certified safe connections, earthing and bonding connections, cable tray and bunch configurations showing clearance and segregation of cables. For cable penetrations through watertight, gastight, and fire-rated bulkheads and decks, evidence of penetration design approval is to be submitted. For watertight and gastight cable penetrations, certificates issued by a competent independent testing laboratory would be acceptable. For fire-rated cable penetrations, certificates issued by an Administration signatory to SOLAS 1974 as amended would be acceptable.

For high voltage systems see installation requirements given in 4-8-5/3.9.

For high voltage cables the minimum cable bending radii and securing arrangements, taking the relevant recommendations of the cable manufacturer into consideration, are to be included. Cable tray segregation (HV to HV and HV to LV arrangements) are also to be included.

5.3.2 Hazardous Area Plan and Equipment Data

The plan is to show hazardous area delineation together with the following:

- i) When the selection of the equipment has been finalized, a list/booklet identifying all equipment in the hazardous areas and the particulars of the equipment is to be submitted for review. Particulars of the equipment are to include manufacturers' names, model designations, rating (flammable gas group and temperature class), the method of protection (flameproof, intrinsically safe, etc.), any restrictions in their use, and document of certification. A copy of this list/booklet is to be maintained on board for future reference.
- ii) For intrinsically-safe systems, also wiring plans, installation instructions with any restrictions imposed by the certification agency.
- iii) Detail of installation for echo sounder, speed log and impressed current cathodic protection system where located in these areas.

5.3.3 Special Hull Penetrations

Details of hull penetrations for installations such as echo sounder, speed log and impressed current cathodic protection system.

5.3.4 Arrangements of Electrical Equipment

Arrangement plans showing the locations of the following equipment and systems:

- Generators, main switchboard, motor control centers, transformers/converters
- Batteries and battery charging and discharging boards
- Emergency source of power, emergency lights
- Interior communication systems
- Emergency alarm system, public addresses system, fire detection and alarm system
- Locations of cable splices and cable junction boxes

5.5 Equipment Plans

The following plans and data, as applicable, are to be submitted for approval before proceeding with the work.

Plans should generally be submitted electronically to ABS. However hard copies will also be accepted.

5.5.1 Rotating Machines

For rotating machines of 100 kW (135 hp) and over intended for essential services (primary and secondary) or for services indicated in 4-8-3/Table 7, plans showing the following particulars are to be submitted: assembly, seating arrangements, terminal arrangements, shafts, coupling, coupling bolts, stator and rotor details together with data of complete rating, class of insulation, designed ambient temperature and temperature rise, degree of protection for enclosures, weights and speeds of rotating parts.

5.5.2 Switchboards, Distribution Boards

Plans showing arrangements and details as indicated below are to be submitted for main and emergency switchboards, distribution boards, battery charger units, uninterruptible power system (UPS) units intended for essential services (primary and secondary), services indicated in 4-8-3/Table 7, battery charging and discharging boards for emergency or transitional source of power:

- Front view
- Schematic diagram
- Protective device rating and setting
- Emergency tripping and preferential tripping features
- Internal power for control and instrumentation
- Type and size of internal control and instrumentation wiring
- Size, spacing, bracing arrangements, rated current carrying capacity and rated short-circuit current of bus bars and bus bar disconnecting device
- Written description of automated functions and operations of the electrical plant

5.5.3 Motor Controllers

For motor controllers of 100 kW (135 hp) and over intended for essential services (primary and secondary) or for services indicated in 4-8-3/Table 7, plans showing the following particulars are to be submitted: front view, degree of protection for enclosure, schematic diagram, current rating of running protection of motor, and type and size of internal wiring.

5.5.4 Motor Control Centers

For motor control centers with aggregate loads of 100 kW (135 hp) and over intended for essential services (primary and secondary) or for services indicated in 4-8-3/Table 7, plans showing the following particulars are to be submitted: front view, degree of protection for enclosure, schematic diagram, current rating of running protection of motor, and type and size of internal wiring.

7 Definitions

7.1 General

The definitions of terms used are in agreement with SOLAS 1974, as amended, and IEC Publication 60092-101, paragraph 1.3, 61439-1 and IEEE 1584, except as provided in 4-8-1/7.3.

7.1.1 Nominal Voltage

Nominal Voltage (U_n) – The nominal value assigned to a circuit or system for the purpose of conveniently designating its voltage class (as 120/240 V, 480/277 V, 600 V). The actual voltage at which a circuit operates can vary from the nominal within a range that permits satisfactory operation of equipment.

U_o (as relates to cable voltage rating) – The rated power frequency voltage between conductor and earth or metallic screen for which the cable is designed.

7.1.2 Earth

Earth – A large conducting body, such as the metal hull of the ship, used as an arbitrary zero of potential.

7.1.3 Pollution Degree

Pollution Degree (of environmental conditions) – A conventional number based on the amount of conductive or hygroscopic dust, ionized gas or salt, and on the relative humidity and its frequency of occurrence resulting in hygroscopic absorption or condensation of moisture leading to reduction in dielectric strength and/or surface resistivity of the insulating materials of devices and components.

7.1.4 Overvoltage Category

Overvoltage Category (of a circuit or within an electrical system) – Conventional number based on limiting the values of prospective transient overvoltages occurring in a circuit and depending on the means employed to influence the overvoltages.

7.1.5 Inhomogeneous Field

Inhomogeneous Field – An electric field which does not have a constant voltage gradient between electrodes.

7.1.6 Overvoltage Withstand Test

Overvoltage Withstand Test (layer test) – Test intended to verify the power-frequency withstand strength along the winding under test and between its phase (strength between turns and between layers in the windings).

7.3 Specific

The following terms are specifically defined for the purposes of Part 4, Chapter 8.

7.3.1 Low Voltage

Low Voltage in these Rules refers to voltages up to and including 1000 V AC and 1500 V DC.

7.3.2 High Voltage

High Voltage in these Rules refers to voltages above 1000 V up to and including 15 kV AC.

7.3.3 Essential Services

Essential Services are those considered necessary for:

- Continuous operation to maintain propulsion and steering (primary essential services);
- Non-continuous operation to maintain propulsion and steering and a minimum level of safety for the vessel's navigation and systems including safety for dangerous cargoes to be carried (secondary essential services); and
- Emergency services as described in 4-8-2/5.5 (each service is either primary essential or secondary essential depending upon its nature).

Examples of primary essential services and secondary essential services are as listed in 4-8-1/Table 1 and 4-8-1/Table 2, respectively.

7.3.4 Minimum Comfortable Condition of Habitability

A condition in which at least services such as cooking, heating, domestic refrigeration, mechanical ventilation, sanitary and fresh water are adequately provided.

7.3.5 Cascade Protection

The application of protective devices in which the device nearest to the source of power has short-circuit ratings equal to or in excess of the maximum prospective short-circuit current, while devices in succeeding steps further from the source have lower short-circuit ratings.

7.3.6 Electrical Power Critical Notations

The following Class notations are dependent upon the supply of electrical power and the services are to be maintained with one generator held in reserve: Refrigeration notations as per 6-2-1/7.1.

9 Basic Requirements

The requirements of Part 4, Chapter 8, as a whole, are intended to assure the satisfactory operation of electrical systems onboard a vessel through:

- The provision of sufficient number and capacity of generators to allow for at least one standby;
- The provision of an emergency source of power and its supply to services needed in an emergency;
- The continuity of supply in the event of an equipment fault or an overload by means of coordinated tripping of protective devices, automatic shedding of non-essential loads, etc.;
- Observation of electrical safety; such as proper sizing and protection of electrical cables, fire retarding properties of insulation materials, appropriate enclosure of equipment, proper installation and tests, etc.; with a view to minimizing the risks of fire and hazard to personnel;
- Design assessment, testing and certification of critical equipment in the systems; and
- Providing judicious attention to the hazards of the cargoes carried and their implications on electrical equipment and system design.

TABLE 1
Primary Essential Services

(a)	Steering gears
(b)	Pumps for controllable pitch propellers
(c)	Scavenging air blower, fuel oil supply pumps, fuel valve cooling pumps, lubricating oil pumps and cooling water pumps for main and auxiliary engines, turbines and shafting necessary for propulsion
(d)	Ventilation necessary to maintain propulsion
(e)	Forced draft fans, feed water pumps, water circulating pumps, vacuum pumps and condensate pumps for steam plants on steam turbine ships, and also for auxiliary boilers on vessels where steam is used for equipment supplying primary essential services
(f)	Oil burning installations for steam plants on steam turbine vessels and for auxiliary boilers where steam is used for equipment supplying primary essential services
(g)	Low duty gas compressor and other boil-off gas treatment facilities supporting boil-off gas usage as fuel to main propulsion or electric power generation machinery.
(h)	Azimuth thrusters which are the sole means for propulsion/steering with lubricating oil pumps, cooling water pumps, etc.
(i)	Electrical equipment for electric propulsion plant with lubricating oil pumps and cooling water pumps
(j)	Electric generators and associated power sources supplying primary essential equipment
(k)	Hydraulic pumps supplying primary essential equipment
(l)	Viscosity control equipment for heavy fuel oil
(m)	Control, monitoring and safety devices/systems of equipment for primary essential services.

TABLE 2
Secondary Essential Services

(a)	Windlass
(b)	Fuel oil transfer pumps and fuel oil treatment equipment
(c)	Lubrication oil transfer pumps and lubrication oil treatment equipment
(d)	Pre-heaters for heavy fuel oil
(e)	Starting air and control air compressors
(f)	Bilge, ballast and heeling pumps
(g)	Fire pumps and other fire extinguishing medium pumps
(h)	Ventilating fans for engine and boiler rooms
(i)	Services considered necessary to maintain dangerous spaces in a safe condition (inert gas system of an oil carrier, ventilation for Ro-Ro cargo spaces, etc.)
(j)	Methods used to comply with 5C-8-7/1 on liquefied gas carriers
(k)	Navigation lights, aids and signals
(l)	Internal communication equipment required by 4-8-2/11.5
(m)	Fire detection and alarm system
(n)	Lighting system
(o)	Electrical equipment for watertight and fire-tight closing appliances
(p)	Electric generators and associated power sources supplying secondary essential equipment
(q)	Hydraulic pumps supplying secondary essential equipment
(r)	Control, monitoring and safety systems for cargo containment systems
(s)	Control, monitoring and safety devices/systems of equipment for secondary essential services
(t)	Ambient temperature control equipment required by 4-8-3/1.17.2
(u)	Watertight Doors (see Sections 3-2-9, 3-2-15 and 3-2-16)

4

CHAPTER 8 Electrical Systems

SECTION 2 System Design

1 Applications

The provisions of this section apply to shipboard electrical power generation and distribution systems. High voltage systems and electric propulsion systems are subject additionally to the provisions of Section 4-8-5. For DC systems, unless specifically stated in this Section and 4-8-5/7, see IEC Publications 60092-201, 60092-202 and 60092-301.

3 Main Source of Electrical Power

3.1 Number and Capacity of Generators

3.1.1 General

The number and capacity of generating sets is to be sufficient under normal seagoing conditions with any one generator in reserve to carry:

- Those electrical loads for essential services and for minimum comfortable conditions of habitability, as defined in 4-8-1/7.3.3 and 4-8-1/7.3.4, as applicable, and
- The electrical loads related to the electric power critical notations listed in 4-8-1/7.3.6.

See also 4-8-2/3.11. In addition, where electrical power is necessary to restore propulsion, the capacity is to be sufficient to restore propulsion to the vessel in conjunction with other machinery, as appropriate, from a dead ship condition, as defined in 4-1-1/1.9.6, within thirty minutes after the blackout. See also 4-8-2/3.1.3.

3.1.2 Consideration for Motor Starting Current

In selecting the capacity of a generating set, particular attention is to be given to the starting current of motors forming part of the system. With any one generator held in reserve as a standby, the remaining generator sets, operating in parallel and initially carrying the loads in 4-8-2/3.1.1, are to have sufficient capacity with respect to the largest idle essential motor on the vessel so that the motor can be started and the voltage drop occasioned by its starting current will not cause any already running motor to stall or control equipment to drop out. The limits of transient voltage variation under suddenly-applied loads are to be in accordance with 4-8-3/3.13.2(c).

For vessels fitted with electric-motor-driven athwartship thrusters to assist maneuvering, the starting and running of this motor may be supported by all of the installed generators, provided arrangements are made such that its starting is conditional upon the requisite generators being available and that it will not cause inadvertent load shedding.

3.1.3 Starting from Dead Ship Condition

In restoring the propulsion from a dead ship condition (see 4-1-1/1.9.6), no stored energy is to be assumed available for starting the propulsion plant, the main source of electrical power and other essential auxiliaries. It is assumed that means are available to start the emergency generator at all times.

The emergency source of electrical power may be used to restore the propulsion, provided its capacity either alone or combined with other available sources of electrical power is sufficient to provide at the same time those services required to be supplied by 4-8-2/5.5.1 to 4-8-2/5.5.8.

The emergency source of electrical power and other means needed to restore the propulsion are to have a capacity such that the necessary propulsion starting energy is available within 30 minutes of blackout, as defined in 4-1-1/1.9.7. Emergency generator stored starting energy is not to be directly used for starting the propulsion plant, the main source of electrical power and/or other essential auxiliaries (emergency generator excluded).

For steam ships, the 30-minute time limit is to be taken as the time from blackout to light-off of the first boiler.

See also 4-8-2/3.11 and 4-8-2/3.13 below.

3.3 Power Supplied by Propulsion Generators

For vessels propelled by electric power and having two or more constant voltage propulsion generating sets, the vessel's service electric power may be derived from this source. See 4-8-5/5.5.1.

3.5 Generators Driven by Propulsion Machinery

3.5.1 Constant Speed Drive

A generator driven by propulsion machinery capable of operating continuously at a constant speed, e.g., those fitted with controllable-pitch propellers, may be considered one of the generators required by 4-8-2/3.1.1, provided that the arrangements stated in *i*) to *iii*) below are complied with:

- i*) The generator and the generating systems are capable of maintaining the voltage and frequency variation within the limits specified in 4-8-3/3.13.2 and 4-8-3/1.9 under all weather conditions during sailing or maneuvering and also while the vessel is stopped.
- ii*) The rated capacity of the generator and the generating systems is safeguarded during all operations given under *i*) and is such that the services required by 4-8-2/3.1.1 can be maintained upon loss of any generator in service.
- iii*) An arrangement is made for starting a standby generator and connecting it to the switchboard, in accordance with 4-8-2/3.11.

3.5.2 Variable Speed Drive

A generator driven by propulsion machinery not capable of operating continuously at a constant speed may be used for normal operational and habitable conditions of the vessel, provided that the arrangements stated in *i*) to *v*) below are complied with. This type of generator will not be counted as one of the generators required by 4-8-2/3.1.1.

- i*) In addition to this type of generator, generators of sufficient and adequate rating are provided, which constitute the main source of electrical power required by 4-8-2/3.1.1.
- ii*) When the frequency variations at the main bus bar exceed the following limits due to the speed variation of the propulsion machinery which drives the generator, arrangements are made to comply with 4-8-2/3.11.

Permanent frequency variation: $\pm 5.5\%$

Transient frequency variation: $\pm 11\%$ (5 sec)

- iii*) The generators and the generating systems are capable of maintaining the voltage and frequency variation within the limits specified in 4-8-3/3.13.2 and 4-8-3/1.9.
- iv*) Where load-shedding arrangements are provided, they are fitted in accordance with 4-8-2/9.9.
- v*) Where the propulsion machinery is capable of being operated from the navigating bridge, means are provided or procedures are in place to ensure that the power supply to essential services is maintained during maneuvering conditions in order to avoid a blackout situation.

3.7 Transformers and Converters

3.7.1 Continuity of Supply

Where transformers and/or converters form a part of the vessel's electrical system supplying essential services and services necessary for minimum comfortable conditions of habitability, as defined in 4-8-1/7.3.3 and 4-8-1/7.3.4, the number and capacity of the transformers and/or converters are to be such that, with any one transformer or converter, or any one single phase of a transformer out of service, the remaining transformers and/or converters or remaining phases of the transformer are capable of supplying power to these loads under normal seagoing conditions.

See 4-8-5/3.3.3 for the additional requirements applicable for high voltage transformers.

3.7.2 Arrangements

Each required transformer is to be located as a separate unit with separate enclosure or equivalent, and is to be served by separate circuits on the primary and secondary sides. Each primary circuit is to be provided with switchgear protective devices in each phase. Each of the secondary circuits is to be provided with a multipole isolating switch. This multipole isolating switch is not to be installed on the transformer casing or its vicinity, to preclude its damage by fire or other incident at the transformer. A circuit breaker provided in the secondary circuit, in accordance with 4-8-2/9.19.2, will be acceptable in lieu of a multipole isolating switch.

3.7.3 Transformers and Converters for Battery Charger

Where batteries connected to a single battery charger are the sole means of supplying DC power to equipment for essential services as defined in 4-8-1/7.3.3 or are used for battery starting systems in 4-8-2/11.11, failure of the single battery charger under normal operating conditions should not result in total loss of these services once the batteries are depleted. In order to ensure continuity of the power supply to such equipment, one of the following arrangements is to be provided:

3.7.3(a) Duplicate battery chargers; or

3.7.3(b) A single battery charger and a transformer/rectifier (or switching converter) which is independent of the battery charger, provided with a change-over switch; or

3.7.3(c) Duplicate transformer/rectifier (or switching converter) units within a single battery charger, provided with a changeover switch.

The above requirements are not applicable for the equipment for the essential services, which contains a single transformer/rectifier with a single AC power supply feeder to such equipment.

For electric starting arrangement for main and auxiliary engines see 4-8-2/11.11.

3.9 Location of Generators

At least one generating station (one or more generators sufficient to supply to essential services) is to be placed in the same space as the main switchboard (and transformers, as applicable) so that, as far as practicable, the occurrence of a fire, flooding or similar casualty in not more than one space cannot completely disrupt the normal electrical supply. An environmental enclosure for the main switchboard such as may be provided by a centralized control room situated within the main boundaries of the space, is not to be considered as separating the switchboard from the generators.

3.11 System Arrangement

3.11.1 General

For vessels of 500 GT and above, where the main source of electrical power is necessary for propulsion and steering of the vessel, the system is to be so arranged that, in the event of the loss of any one of the generators in service, the electrical supply to equipment necessary for propulsion and steering and to ensure safety of the vessel will be maintained or restored in accordance with the provision in 4-8-2/3.11.2 or 4-8-2/3.11.3.

Load shedding of nonessential services and, where necessary, secondary essential services (see 4-8-1/7.3.3) or other arrangements, as may be necessary, are to be provided to protect the generators against sustained overload. See also 4-8-2/9.9.

3.11.2 Single Generator Operation

Where the electrical power is normally supplied by a single generator, provision is to be made upon loss of power for automatic starting and connecting to the main switchboard of a standby generator(s) of sufficient capacity with automatic restarting of the essential auxiliaries in sequential operation, if necessary, to permit propulsion and steering and to ensure the safety of the vessel. Starting and connection to the main switchboard of the standby generator is to be preferably within 30 seconds after loss of the electrical power supply but in no case in more than 45 seconds.

3.11.3 Multiple Generators Operation

Where the electrical power is normally supplied by more than one generator set simultaneously in parallel operation, the system is to be so arranged that in the event of the loss of any one of the generators in service, the electrical supply to equipment necessary for propulsion and steering and to ensure the safety of the vessel will be maintained by the remaining generator(s) in service.

3.13 Main Switchboard

Where the main source of electrical power is necessary for propulsion of the vessel, the main bus bar is to be subdivided into at least two sections, which are normally to be connected by circuit breakers or other approved means. So far as is practicable, the connection of generator sets and other duplicated equipment is to be equally divided between the sections.

If the arrangement is such that the main switchboard is divided into separate sections which are interconnected by cable, the cable is to be protected at each end against faults.

5 Emergency Source of Electrical Power

5.1 General

5.1.1 Basic Requirement

A self-contained emergency source of electrical power is to be provided so that in the event of the failure of the main source of electrical power, the emergency source of power will become available to supply power to services that are essential for safety in an emergency. Passenger vessels are subject to the requirements in 5C-7-5/13.5.

5.1.2 Scope of Provision

A self-contained emergency source of electrical power includes prime mover and its starting equipment, generator, fuel tank, emergency switchboard, associated transforming equipment, if any, transitional source of emergency power, if applicable, and emergency lighting switchboard and associated transformers, if applicable.

5.1.3 Requirements by the Governmental Authority

Attention is directed to the requirements of governmental authority of the country, whose flag the vessel flies, for emergency services and accumulator batteries required in various types of vessels.

5.3 Location

5.3.1 General

The self-contained emergency source of electrical power is to be located above the uppermost continuous deck, outside the machinery casing, and is to be readily accessible from the open deck. It is not to be located forward of the collision bulkhead. The space is to contain only machinery and equipment supporting the normal operation of the emergency power source.

5.3.2 Separation from Machinery Space of Category A

The location of the self-contained emergency source of electrical power, associated transforming equipment, if any, the transitional source of emergency electrical power, the emergency switchboard and emergency lighting switchboard in relation to the main source of electrical power is to be such that a fire or other casualty in the space containing the main source of electrical power or in any machinery space of category A will not interfere with the supply, control and distribution of emergency electrical power.

The space containing the self-contained emergency source of electrical power and its associated equipment as stated above including trunks to such spaces are not to be contiguous to the boundaries of machinery spaces of category A or those spaces containing the main source of electrical power.

The following alternative arrangements may be considered:

- i) Separation by a cofferdam having dimensions as required for ready access and extending at least 150 mm (6 in.) beyond the boundaries of the space containing the self-contained emergency source of power and its associated equipment as stated above. See 4-8-2/Figure 1 below. Except for cables feeding services located in the machinery space, emergency electrical cables are not to be installed in such cofferdams unless the cofferdam is insulated to A-60.

FIGURE 1
Cofferdam with Extension Beyond the Boundaries of the Space Containing the Emergency Source

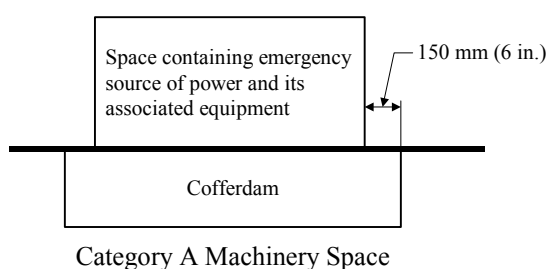

- ii) Separation by a cofferdam having dimensions as required for ready access between category A machinery space and the space containing emergency source of power and its associated equipment as stated above without extension beyond the boundaries. Any contiguous lines between these spaces at the corner of the cofferdam is to be insulated to A-60 for a length of 450 mm (18 in) at the category A machinery space side. See 4-8-2/Figure 2 below.

FIGURE 2
Cofferdam without Extension Beyond the Boundaries of the Space Containing the Emergency Source

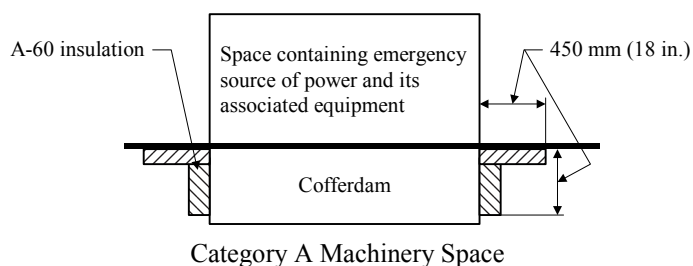

- iii) The contiguous boundaries insulated to A-60 with the insulation extending at least 450 mm (18 in.) beyond the boundary of the space containing the self-contained emergency source of power and its associated equipment as stated above. See 4-8-2/Figure 3 below.

The arrangements indicated in 4-8-2/Figure 3 below can be considered only when it can be shown that the arrangements are in compliance with the requirements of the flag administration.

FIGURE 3
Boundary Insulated to A-60 with the Insulation Extending Beyond the Boundaries of the Space Containing the Emergency Source

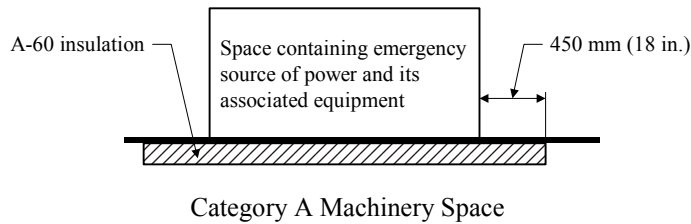

5.3.3 Separation from Other Spaces

Spaces containing the emergency sources of electrical power are to be separated from spaces other than machinery space of category A by fire rated bulkheads and decks, in accordance with Part 3, Chapter 4 of these Rules or Chapter II-2 of SOLAS.

5.5 Emergency Services

- i)* The electrical power available from the emergency source is to be sufficient to supply all those services that are essential for safety in an emergency, due regard being paid to such services as may have to be operated simultaneously. Where the sum of the loads on the emergency generator switchboard exceeds the power available, an analysis demonstrating that the power required to operate the services simultaneously is to be produced. The analysis is to be submitted for review in support of the sizing of the emergency generator.
- ii)* The emergency source of electrical power is to be capable, having regard to starting currents and the transitory nature of certain loads, of supplying simultaneously at least the services listed in 4-8-2/Table 1 for the period specified.

TABLE 1
Services to be Powered by an Emergency Source and by a Transitional Source

Service	Gross Tons	Duration (hours)				
		500 GT or over ⁽¹⁾		Under 500 GT		
	Electrical Plant's Capacity	---		75 kW or over ⁽²⁾		Under 75 kW
Emergency Power Consumers	Emergency Power	Transitional Power	Emergency Power	Transitional Power	Emergency Power ⁽³⁾	
Emergency lighting	At every muster and embarkation station for survival craft, their launching appliance, over the sides for launching	3	0.5	2	0.5	2
	At the area of water into which the survival craft is to be launched	3	0.5	2	0.5	2
	In all service and accommodation alleyways, stairways, and exits, personnel lift cars, and personnel lift trunks	18	0.5	6	0.5	6
	In the machinery spaces and main generating stations including their control positions	18	0.5	6	0.5	6
	In all control stations, machinery control rooms, and at each main and emergency switchboard	18	0.5	6	0.5	6
	At all storage positions for fireman's outfits	18	0.5	6	0.5	6
	At the steering gear	18	0.5	6	0.5	6
	At the emergency fire pump, the sprinkler pump, the emergency bilge pump, their starting positions	18	0.5	6	0.5	6
	In all cargo pump rooms	18	0.5	6	0.5	
	Floodlight and perimeter lights on helicopter landing decks	18	0.5	6	0.5	
Navigation lights	The navigation lights and other lights required by the International Regulations for Preventing Collisions at Sea	18	0.5	6	0.5	
Communication	Radio equipment as required by Chapter IV of SOLAS	18	0.5	6	0.5	
	All internal communication equipment as required in an emergency, see 4-8-2/11.5	18	0.5	6	0.5	
	Intermittent operation of daylight signaling lamp, ship's whistle, manually operated call points, all internal signals that are required in an emergency, see 4-8-2/11.7	18	0.5	6	0.5	
Navigation Aids	Navigational equipment required by Regulation V/19 and V/20 of SOLAS	18 ⁽⁴⁾				
Alarm Systems	Fire detection and alarm	18	0.5	6 ⁽⁷⁾	0.5	
	Gas detection and alarm system	18	0.5	6	0.5	
	General alarm system	18	0.5	6 ⁽⁸⁾	0.5 ⁽⁸⁾	
Fire pumps	Emergency fire pump (see 4-7-3/1.5.3); one of the fire pumps required by 4-7-3/1.5.1 and fixed pressure water-spray system pump (see 4-7-2/1.1.1iii) if dependent upon the emergency generator for its source of power	18				
Steering gear	Steering gears required to comply with 4-3-4/11.9	0.5 ^(5, 6)		0.17 ⁽⁵⁾		

TABLE 1 (continued)
Services to be Powered by an Emergency Source and by a Transitional Source

Service	Gross Tons	Duration (hours)				
		500 GT or over ⁽¹⁾		Under 500 GT		
	Electrical Plant's Capacity	---		75 kW or over ⁽²⁾		Under 75 kW
Emergency Power Consumers	Emergency Power	Transitional Power	Emergency Power	Transitional Power	Emergency Power ⁽³⁾	
Control & Maneuvering System	Remote propulsion control and monitoring system for ACC, ACCU and ABCU notations, see 4-9-5/3.5 and 4-9-6/3.7	0.5		0.5		
Other emergency services	Free-full lifeboat secondary launching appliance, if not dependent on gravity, stored mechanical power or other manual means	0.5		0.5		
	Power-operated watertight door, as required by 4-9-8/1.3.4	0.5		0.5		

Notes:

- 1 See 4-8-2/5.5 and 4-8-2/5.11
- 2 See 4-8-2/5.21
- 3 See 4-8-5/9
- 4 Vessels less than 5,000 GT may be waived if approved by the Administration
- 5 Applicable for rudder stock diameter over 230 mm (9 in.)
- 6 10 minutes continuous operation on vessels of less than 10,000 GT
- 7 Where a fixed fire detection and fire alarm system is installed
- 8 Applicable for vessels over 100 GT, see 4-8-2/11.7

5.7 Vessels on Short Duration Voyages

In a vessel engaged regularly in voyages of short duration and an adequate standard of safety is attained, a lesser period than the 18 hour period specified in 4-8-2/5.5 but not less than 12 hours may be accepted.

5.9 Power Source

The emergency source of electrical power may be a generator, an accumulator battery or a combination of these.

5.9.1 Generator

Where the emergency source of electrical power is a generator, it is to be:

- i) Driven by a prime mover with all necessary auxiliary systems independent from the main source of electrical power systems. The auxiliary systems, which may include fuel system, starting equipment, cooling system, ventilation and lubricating oil system, are to be installed as near as is practicable to the generator prime mover, preferably located in the same space as the generator prime mover unless the safe operation of the generator prime mover would thereby impaired.
- ii) Started automatically upon failure of the main source of electrical power supply and automatically connected to the emergency switchboard supplying those services referred to in 4-8-2/5.5 in not more than 45 seconds.
- iii) Provided with an adequate capacity of fuel with a flashpoint (closed cup test) of not less than 43°C (110°F) for the emergency generator prime mover. The use of fuel oil having a flashpoint of less than 60°C (140°F) but not less than 43°C (110°F) is to be subject to the provisions of 4-6-4/13.1.2.

Where the emergency generator, as specified above, is not provided with automatic starting, a transitional source of emergency electrical power, as specified in 4-8-2/5.11, is to be fitted.

Where it is intended to use fuel with a flash point of less than 60°C (140°F) then details of the precautions used to address the associated hazardous area issues are to be submitted to ABS for review.

5.9.2 Accumulator Battery

Where the emergency source of electrical power is an accumulator battery it is to be capable of:

- i) Automatically connecting to the emergency switchboard in the event of failure of the main source of electrical power;
- ii) Immediately supplying at least those services specified in 4-8-2/5.11; and
- iii) Carrying the emergency electrical load without recharging while maintaining the voltage of the battery throughout the discharge period within 12% above or below its nominal voltage.

5.11 Transitional Source of Power

The transitional source of emergency electrical power where required by 4-8-2/5.9.1 is to consist of an accumulator battery which is to operate without recharging while maintaining the voltage of the battery throughout the discharge period within 12% above or below its nominal voltage and be of sufficient capacity and be so arranged as to supply automatically, in the event of failure of either the main or the emergency source of electrical power, for half an hour at least the following services if they depend upon an electrical source for their operation:

- i) The emergency lighting and navigation lights required by 4-8-2/Table 1. For this transitional phase, the required emergency electric lighting, in respect of the machinery space and accommodation and service spaces may be provided by permanently fixed, individual, automatically charged, relay operated accumulator lamps; and
- ii) Communication services and alarm systems required by 4-8-2/Table 1 unless such services have an independent supply for the period specified from an accumulator battery suitably located for use in an emergency.

5.13 Emergency Switchboard

5.13.1 Location of Emergency Switchboard

The emergency switchboard is to be installed as near as is practicable to the emergency source of electrical power.

Where the emergency source of electrical power is a generator, the emergency switchboard is to be located in the same space unless the operation of the emergency switchboard would thereby be impaired.

No accumulator battery fitted in accordance with 4-8-2/5.9.2 or 4-8-2/5.11 is to be installed in the same space as the emergency switchboard. An indicator is to be mounted on the main switchboard or in the machinery control room to indicate when these batteries are being discharged.

5.13.2 Interconnector Feeder Between Emergency and Main Switchboards

The emergency switchboard is to be supplied during normal operation from the main switchboard by an interconnector feeder which is to be protected at the main switchboard against overload and short circuit and which is to be disconnected automatically at the emergency switchboard upon failure of the main source of electrical power.

In designs where the main switchboard voltage is different from that of the emergency switchboard the power to the emergency switchboard is to be supplied from the main ship service switchboard.

The circuit coordination is to be arranged such that all the outgoing circuits from the main ship service switchboard will coordinate with the step-down transformer protection.

Note: For the purpose of this Rule, the main ship service switchboard is a switchboard which is connected to the secondary of the step-down transformer producing the required voltage.

5.13.3 Feedback Operation

Where the emergency switchboard is arranged for feedback operation, the interconnector feeder is also to be protected at the emergency switchboard at least against short circuit, which is to be coordinated with the emergency generator circuit breaker.

In addition, this interconnector feeder protective device is to trip to prevent overloading of the emergency generator which might be caused by the feedback operation.

5.13.4 Non-emergency Services and Circuits

The emergency generator may be used, exceptionally and for short periods, to supply non-emergency circuits during the blackout situation (see 4-1-1/1.9.7), dead ship condition (see 4-1-1/1.9.6), and routine testing (to check its proper operation, see 4-8-2/5.13.5) provided that measures are taken to safeguard the independent emergency operation under all circumstances. The generator is to be safeguarded against overload by automatically shedding such non-emergency services so that supply to the required emergency loads is always available.

For ready availability of the emergency source of electrical power, arrangements are to be made, where necessary, to disconnect automatically non-emergency circuits from the emergency switchboard to ensure that electrical power is available automatically to the emergency circuits.

For use of the emergency generator in port, see 4-8-2/5.17.

5.13.5 Arrangements for Periodic Testing

Provision is to be made for the periodic testing of the complete emergency system and is to include the testing of the automatic starting system.

5.15 Starting Arrangements for Emergency Generator Sets

5.15.1 General

The emergency generators are to be capable of being readily started in their cold condition at a temperature of 0°C (32°F). If this is impracticable or if lower temperatures are likely to be encountered, heating arrangements are to be fitted.

5.15.2 Number of Starts

Each emergency generator arranged to be automatically started is to be equipped with starting devices with a stored energy capability of at least three consecutive starts. The source of stored energy is to be protected to preclude critical depletion (i.e., not to be depleted beyond a level where starting by manual intervention is still possible) by the automatic starting system, unless a second independent means of starting is provided. In addition, a second source of energy is to be provided for an additional three starts within thirty minutes unless manual starting can be demonstrated to be effective.

5.15.3 Stored Energy for Starting

The stored energy for starting the emergency generator set is to be maintained at all times, as follows:

- i) Electrical and hydraulic starting systems are to be maintained from the emergency switchboard.
- ii) Compressed air starting systems may be maintained by the main or auxiliary compressed air receivers through a suitable non-return valve or by an emergency air compressor which, if electrically driven, is supplied from the emergency switchboard.
- iii) All of these starting, charging and energy storing devices are to be located in the emergency generator space; these devices are not to be used for any purpose other than the operation of the emergency generating set. This does not preclude the supply to the air receiver of the emergency generating set from the main or auxiliary compressed air system through the non-return valve fitted in the emergency generator space.

5.15.4 Manual Starting

Where automatic starting of the emergency generator in accordance with 4-8-2/5.9.1 is not required, manual starting is permissible, such as manual cranking, inertia starters, manually charged hydraulic accumulators, or power charge cartridges, where they can be demonstrated as being effective.

When manual starting is not practicable, the requirements of 4-8-2/5.15.2 and 4-8-2/5.15.3 above shall be complied with, except that starting may be manually initiated.

5.17 Use of Emergency Generator in Port (for Vessels 500 GT and Over)

Unless instructed otherwise by the Flag Administration, the emergency generator may be used during lay time in port for supplying power to the vessel, provided the following requirements are complied with.

5.17.1 Arrangements for the Prime Mover

5.17.1(a) Fuel oil tank. The fuel oil tank for the prime mover is to be appropriately sized and provided with a level alarm, which is to be set to alarm at a level where there is still sufficient fuel oil capacity for the emergency services for the period of time required by 4-8-2/5.5. See also 5-1-2/7.3.1 for vessels under the provisions of the IMO Code for Safety for Special Purpose Ships (SPS Code).

5.17.1(b) Rating. The prime mover is to be rated for continuous service.

5.17.1(c) Filters. The prime mover is to be fitted with fuel oil and lubricating oil filters in accordance with 4-6-5/3.5.4 and 4-6-5/5.5.2, respectively.

5.17.1(d) Monitoring. The prime mover is to be fitted with alarms, displays and automatic shutdown arrangements as required in 4-9-6/Table 6, except that for fuel oil tank low-level alarm, 4-8-2/5.17.1(a) above is to apply instead. The displays and alarms are to be provided in the centralized control station. Monitoring at the engineers' quarters is to be provided as in 4-9-6/19.

5.17.1(e) Fire detection. The emergency generator room is to be fitted with fire detectors. Where the emergency generator is located in a space separated from the emergency switchboard, fire detectors are to be located in each space. The fire detection and alarm system is to be in compliance with 4-7-2/1.13 and may be a part of another system.

5.17.2 System Arrangements

5.17.2(a) Independence. The power supply circuits, including control and monitoring circuits, for the use of an emergency generator in port are to be so arranged and protected that any electrical fault, except for the emergency generator and the emergency switchboard, will not affect the operation of the main and emergency services.

5.17.2(b) Changeover arrangement. Means are to be provided to readily change over to emergency operation.

5.17.2(c) Overload prevention. The generator is to be safeguarded against overload by automatically shedding such other loads so that the supply to the required emergency loads is always available.

5.17.3 Operational Instruction

Operational instructions such as that on the fuel oil tank level, harbor/seagoing mode changeover arrangements, etc. are to be provided on board. Before the vessel is under way, all valves, switches, etc., are to be in the positions for the intended mode of operation of the emergency generator and the emergency switchboard. Such instructions are to be distinctly posted at the emergency generator room. Planned maintenance is to be carried out only while in port.

5.19 Alarms and Safeguards for Emergency Diesel Engines

5.19.1 Information to be Submitted

Information demonstrating compliance with these requirements is to be submitted for review. The information is to include instructions to test the alarm and safety systems.

5.19.2 Alarms and Safeguards

5.19.2(a) Alarms and safeguards are to be fitted in accordance with 4-8-2/Table 2.

5.19.2(b) The safety and alarm systems are to be designed to ‘fail safe’. The characteristics of the ‘fail safe’ operation are to be evaluated on the basis not only of the system and its associated machinery, but also the complete installation, as well as the ship.

5.19.2(c) Regardless of the engine output, if shutdowns additional to those specified in 4-8-2/Table 1 are provided, except for the overspeed shutdown, they are to be automatically overridden when the engine is in automatic or remote control mode during navigation.

5.19.2(d) The alarm system is to function in accordance with 4-9-2/3.1.2 and 4-9-2/7, with additional requirements that grouped alarms are to be arranged on the bridge.

5.19.2(e) In addition to the fuel oil control from outside the space, a local means of engine shutdown is to be provided.

5.19.2(f) Local indications of at least those parameters listed in 4-8-2/Table 2 are to be provided within the same space as the diesel engines and are to remain operational in the event of failure of the alarm and safety systems.

TABLE 2
Alarms and Safeguards for Emergency Diesel Engines [See 4-8-2/5.19]

<i>Systems</i>	<i>Monitored Parameters</i>		<i>A</i>	<i>Auto Shut down</i>	<i>Notes</i> [A = Alarm; x = apply]
Fuel oil	A1	Leakage from pressure pipes	x		
Lubricating oil	B1	Temperature – high	x		For engines having a power of 220 kW or more.
	B2	Lubricating oil pressure – low	x		
	B3	Oil mist in crankcase, mist concentration – high; or Bearing temperature – high; or Alternative arrangements	x		For engines having a power of 2250 kW (3000 hp) and above or having a cylinder bore of more than 300 mm (11.8 in.). See 4-2-1/7.2.
Cooling medium	C1	Pressure or flow – low	x		For engines having a power of 220 kW or more.
	C2	Temperature – high	x		
Engine	D1	Overspeed activated	x	x	For engines having a power of 220 kW or more.

5.21 Vessels Less than 500 GT Having Electrical Plants of 75 kW and Above

5.21.1 General

This requirement is intended for vessels less than 500 GT having electrical plants of an aggregate capacity of 75 kW and above. The emergency source of electrical power is to be self-contained and readily available. 4-8-2/5.3, and 4-8-2/5.9 through 4-8-2/5.13 are also applicable. Where the source of electrical power is a battery, see 4-8-4/5 for the installation. For emergency lighting, a relay-controlled, battery-operated lantern is acceptable.

5.21.2 Capacity

The emergency source of electrical power is to be capable of supplying simultaneously the services for the period as specified in 4-8-2/Table 1.

5.21.3 Requirements by the Governmental Authority

Attention is directed to the requirements of the governmental authority of the country whose flag the vessel flies for the emergency services and the accumulator batteries required in various types of vessels.

7 Distribution System

7.1 General

The following are recognized as standard systems of distribution. Distribution systems other than these will be considered.

- Two-wire direct current
- Two-wire single-phase alternating current
- Three-wire three-phase alternating current
- Four-wire three-phase alternating current with solidly earthed neutral but not with hull return

7.3 Hull Return Systems

7.3.1 General

A hull return system is not to be used, with the exception as stated below:

- Impressed current cathodic protection systems;
- Limited locally earthed system, provided that any possible resulting current does not flow through any hazardous locations;
- Insulation level monitoring devices, provided the circulation current does not exceed 30 mA under all possible conditions.
- Current-carrying parts with potential to earth are to be protected against accidental contact.

7.3.2 Final Subcircuits and Earth Wires

Where the hull return system is used, all final subcircuits, i.e., all circuits fitted after the last protective device, are to consist of two insulated wires, the hull return being achieved by connecting to the hull one of the bus bars of the distribution board from which they originate. The earth wires are to be in accessible locations to permit their ready examination and to enable their disconnection for testing of insulation.

7.5 Earthed AC Distribution System

7.5.1 General Earthing Arrangement

For earthed distribution systems, regardless of the number of power sources, the neutral of each power source, including that of the emergency generator where applicable, is to be connected in parallel and earthed at a single point. Reference should be made to manufacturer-specified allowable circulating currents for neutral-earthed generators.

7.5.2 System Earthing Conductor

System earthing conductors are to be independent of conductors used for earthing of non-current carrying parts of electrical equipment. See 4-8-4/23.3 for installation details and earth conductor sizing. Four-wire three-phase AC systems having an earthed neutral are not to have protective devices fitted in the neutral conductors. Multipole switches or circuit breakers which simultaneously open all conductors, including neutral, are allowed. In multiple-generator installations, each generator's neutral connection to earth is to be provided with a disconnecting link for maintenance purpose. Transformer neutral is not to be earthed unless all corresponding generator neutrals are disconnected from the system (e.g., during shore supply). See 4-8-4/23.3.

7.7 Cable Sizing

This Paragraph applies to cables conforming to IEC Publication 60092-353 or IEC Publication 60092-3. Cables conforming to other standards are to be sized in accordance with corresponding provisions of that standard. For marine cable standards acceptable to ABS, see 4-8-3/9.1.

7.7.1 Cable's Current Carrying Capacity

7.7.1(a) General. Cable conductor size is to be selected based on the current to be carried such that the conductor temperature, under normal operating conditions including any overload condition that may be expected, does not exceed the maximum rated temperature of the cable insulation material. The selected cable type is to have a maximum rated temperature at least 10°C (18°F) higher than the maximum ambient temperature likely to exist at the location where the cable is installed.

7.7.1(b) Current carrying capacities. The maximum current carrying capacities of cables are to be obtained from 4-8-3/Table 6. These values are applicable, without correction factors for cables installed either in single- or double-layer in cable tray, or in a bunch in cable trays, cable conduits or cable pipes where the number of cables in the bunch does not exceed six. The ambient temperature is to be 45°C (113°F) or less.

7.7.1(c) Current carrying capacity correction. Where more than six cables which may be expected to operate simultaneously at their full rated capacity are laid close together in a bunch in such a way that there is an absence of free air circulation around them a reduction factor of 0.85 is to be applied to the current carrying capacity of the cables.

The 0.85 correction factor is also to be applied in the case:

- i) Where fire stops forming a fire protective mat, with which cable runs are wrapped for a length of at least 500 mm every 14 m (19.7 inch/46 ft) of horizontal cable runs, or every 6 m (19.7 ft) of vertical cable runs where free air circulation around the length of wrapped cables is impeded, and;
- ii) Where fire stops by fire protection coating are applied on the cables laid and bunched, and;
- ii) Where the fire stops are used in installations where more than six cables are expected to be operated simultaneously at their full rated capacity.

Consideration of not applying the aforementioned correction factor may be given where the conductor temperature for all cables meets the criteria of 4-8-2/7.7.1(a) by demonstrating through temperature rise calculations/heat transfer analyses or tests under the approved procedures in the worst case scenario of simultaneous cable operation in the bunch or wrapped together.

7.7.1(d) Voltage drop. Voltage drop is to be taken into account in determining cable size. The voltage drop in the conductors while carrying the maximum current under normal steady condition is not to exceed 6% of the nominal voltage at any point of the installation. For cables connected to batteries with a voltage not exceeding 50 V this figure may be increased to 10%.

7.7.1(e) Minimum conductor sizes. Conductor size is not to be less than those given in the following table for each application as shown:

Size mm ² (circ. mils)	Application
1.0 (1.973.5)	Power and lighting
1.5 (2960.3)	Motor feeder cables
0.5 (986.8)	Control cables
0.5 (986.8)	Signaling and communication cables for essential services, except those assembled by the equipment manufacturer
0.35 (690.8)	Communication cables for non-essential services, except those assembled by the equipment manufacturer

7.7.2 Generator Cable

Generator cable is to have a current carrying capacity of not less than the rated current or the rated continuous overload current of the generator.

7.7.3 Transformer Cable

Cables provided for primary and secondary circuits of transformers are to have current carrying capacities not less than the rated primary and secondary currents, respectively.

7.7.4 Motor Control Center Feeder

Feeder cables supplying to motor control centers are to have a continuous current-carrying capacity not less than 100% of the sum of the rated current of all motors connected to the motor control center. Feeder cables of lesser current capacity are permitted, where the design is such that connected consumers are not operated simultaneously, under any operating mode.

7.7.5 Distribution Panel Feeder

Feeder cables supplying to distribution panels or to any sub-distribution panels are to have current-carrying capacity of not less than 100% of the sum of the rated currents of all connected consumers. Where connected consumers are not operated simultaneously, feeder cables of lesser current capacity are permitted provided, that they are protected in accordance with 4-8-2/9.13 below.

7.7.6 Motor Branch Circuit

A separate circuit is to be provided for each motor having a full-load current of 6 A or more. The cables are to have a carrying capacity of not less than 100% of the motor full-load current rating. Branch circuit conductor for each motor is not to be less than 1.5 mm². Circuit-disconnecting devices are to be provided for each motor branch circuit and to be in accordance with 4-8-3/5.7 and 4-8-4/9.3.

7.7.7 Lighting Circuits

Cable for a branch lighting circuit is to have the current carrying capacity of not less than the sum of the full load currents of the connected lighting fixtures.

7.7.8 Protection of Feeder Size Reduction

The size of feeder conductors is normally to be uniform for the total length, but may be reduced beyond any intermediate distribution board, provided that the reduced size section of the feeder is protected by the overload device at the board at which the feeder size is reduced.

7.9 Segregation of Power Circuits

Separate feeders are to be provided for normal vessels service loads and emergency service loads.

7.11 Steering Gear Power Supply Feeders

Each electric or electro-hydraulic steering gear is to be served by at least two feeders fed directly from the main switchboard; however, one of the feeders may be supplied through the emergency switchboard. In the event that the steering gear operates a rudder with required upper rudder stock diameter of 230 mm (9 in.) or more (see 4-3-4/11.9), one of these feeders must be supplied through the emergency switchboard.

For vessels fitted with alternative propulsion and steering arrangements, such as azimuthing propulsors, where the propulsion power exceeds 2,500kW per thruster unit, see 4-3-5/5.13.3.

An electric or electro-hydraulic steering gear fitted with duplicated power units is to have each of these units served by one of the feeders supplying this steering gear. An auxiliary electric or electro-hydraulic steering gear associated with a main electric or electro-hydraulic steering gear may be connected to one of the circuits supplying this main steering gear. The feeders supplying an electric or electro-hydraulic steering gear are to have adequate rating for supplying all motors, control systems and instrumentation which are normally connected to them and operated simultaneously.

The feeders are to be separated throughout their length as widely as is practicable.

7.13 Lighting System

7.13.1 Main Lighting System

A main electric lighting system served by the main source of electric power is to be provided. This lighting system is to provide illumination throughout those parts the vessel normally accessible to and used by personnel on board.

7.13.2 System Arrangement

7.13.2(a) Main Lighting System. The arrangement of the main electric lighting system is to be such that a fire or other casualty in spaces containing the main source of electrical power, associated transforming equipment, if any, the main switchboard and the main lighting switchboard will not render any emergency electric lighting systems and navigation lights required by 4-8-2/Table 1 inoperative.

7.13.2(b) Emergency Lighting System. The arrangement of the emergency electric lighting system is to be such that a fire or other casualty in spaces containing the emergency source of electrical power, associated transforming equipment, if any, the emergency switchboard and the emergency lighting switchboard will not render the main electric lighting systems required by 4-8-2/7.13.1 inoperative.

7.13.3 Lighting Circuits in Machinery Spaces and Accommodation Spaces

In spaces such as:

- Public spaces;
- Category A machinery spaces;
- Galleys;
- Corridors;
- Stairways leading to boat-decks, including staintowers and escape trunks

there is to be more than one final sub-circuit for lighting, arranged in such a way that failure of any one circuit does not leave these spaces in darkness. One of the circuits may be supplied from the emergency switchboard.

7.15 Ventilation System Circuits

Ventilation fans for cargo spaces are to have feeders separate from those for accommodations and machinery spaces. In general, power ventilation is to be capable of being stopped from a location outside the space ventilated, as indicated in 4-8-2/11.9. See also 4-7-2/3.7.3.

7.17 Cargo Space Circuits

All lighting and power circuits for cargo space are to be controlled by multiple-pole switches situated outside the space. A light indicator or other means is to be provided on the multipole-linked switch to show whether the circuit is live.

7.19 Electric Space Heater Circuits

Each heater is to be connected to a separate final branch circuit. However, a group of up to 10 heaters with aggregate current not exceeding 16 A may be connected to a single final branch circuit.

7.21 Harmonics

The total harmonic distortion (THD) in the voltage waveform in the distribution systems is not to exceed 8% and any single order harmonics not to exceed 5%. Other higher values may be accepted provided the distribution equipment and consumers are designed to operate at the higher limits. This relaxation on THD limits is to be documented (harmonic distortion calculation report) and made available on board as a reference for the Surveyor at each periodical survey. Where higher values of harmonic distortion are expected, any other possible effects, such as additional heat losses in machines, network resonances, errors in control and monitoring systems are to be considered. See also 4-8-2/9.22 and 4-8-2/9.23.

9 System Protection

9.1 General

Each electrical system is to be protected against overload and short circuit by automatic protective devices, so that in the event of an overload or a short circuit, the device will operate to isolate it from the systems:

- To maintain continuity of power supply to remaining essential circuits; and
- To minimize the possibility of fire hazards and damage to the electrical system.

These automatic protective devices are to protect each non-earthed phase conductors (e.g., multipole circuit breakers or fuses in each phase).

In addition, where the possibility exists for generators to be overloaded, load-shedding arrangements are to be provided to safeguard continuity of supply to essential services

The following are exceptions:

- Where it is impracticable to do so, such as engine starting battery circuits.
- Where, by design, the installation is incapable of developing overload, in which case, it may be protected against short circuit only.
- Steering circuits; see 4-8-2/9.17.5.

9.3 Protection Against Short Circuit

9.3.1 General

Protection against short circuit is to be provided for each non-earthed conductor (multipole protection) by means of circuit breakers, fuses or other protective devices.

9.3.2 Short-circuit Data

In order to establish that protective devices throughout the electrical system (e.g., on the main and emergency switchboards and sub-distribution panels) have sufficient short-circuit breaking and making capacities, short-circuit data as per 4-8-1/5.1.3 are to be submitted.

9.3.3 Rated Breaking Capacity

The rated breaking capacity of every protective device is not to be less than the maximum prospective short-circuit current value at the point of installation. For alternating current (AC), the rated breaking capacity is not to be less than the root mean square (rms) value of the prospective short-circuit current at the point of installation. The circuit breaker is to be capable of breaking any current having an AC component not exceeding its rated breaking capacity, whatever the inherent direct current (DC) component may be at the beginning of the interruption.

9.3.4 Rated Making Capacity

The rated making capacity of every switching device which may be closed on short circuit is to be adequate for the maximum peak value of the prospective short-circuit current at the point of installation. The switching device is to be capable of closing onto a current corresponding to its making capacity without opening within a time corresponding to the maximum time delay required.

9.3.5 Backup Fuse Arrangements

Circuit breakers having breaking and/or making capacities less than the prospective short-circuit current at the point of application will be permitted, provided that such circuit breakers are backed up by fuses which have sufficient short-circuit capacity for that application. Current-limiting fuses for short-circuit protection may be without limitation on current rating, see 4-8-2/9.5.

9.3.6 Cascade Protection

Cascade protection may be permitted, subject to special consideration. Such special consideration is not intended for new construction vessels, however may be granted when modifications are performed to existing vessels. The cascade protection is to be arranged such that the combination of circuit protective devices has sufficient short-circuit breaking capacity at the point of application

(see 4-8-2/9.3.3). All circuit protective devices are to comply with the requirements for making capacity (see 4-8-2/9.3.4). Cascade protection is not to be used for circuits of primary essential services. Where cascade protection is used for circuits of secondary essential services, such services are to be duplicated, provided with means of automatic transfer and the automatic transfer is to alarm at a manned location. Cascade protection may be used for circuits of non-essential services.

9.5 Protection Against Overload

Circuit breakers and fuses for overload protection are to have tripping characteristics (overcurrent trip time) which adequately protect all elements in the system during normal and overload conditions having regard to overload capacity of each of these elements.

Fuses of greater than 320 A are not to be used for overload protection. However, current-limiting fuses may be used for short-circuit protection without current rating limitation.

The rating or setting of the overload protective device for each circuit is to be permanently indicated on or at the location of the protective device.

For earthed AC distribution system, see 4-8-2/7.5.2.

9.7 Coordination of Protective Devices

9.7.1 General Requirements

Protective devices are to be selected such that, where considered in series, their tripping characteristics will allow, in the event of a fault (overload or short circuit), the protective device nearest to the fault to open first, thus eliminating the faulted portion from the system.

Protective devices upstream of the fault are to be capable of carrying for the necessary duration the short-circuit current and the overload current, without opening, to allow the device nearest to the fault to open.

Coordination is to be provided for the following:

- Between generator protective device, bus tie, bus feeder protective device, and feeder protective devices;
- Between feeder and branch circuit protective devices for essential services except for cascade protection in 4-8-2/9.3.6; and
- Between protective devices of emergency generator, emergency feeders and branch circuits.

For main and emergency generators, the circuit breakers are to open to prevent the generators from being damaged by thermal stress due to the fault current.

9.7.2 Coordination Studies

For verification of compliance with the above, a protective device coordination study in accordance with 4-8-1/5.1.4 is to be submitted for review.

9.9 Load Shedding Arrangements

9.9.1 Provision for Load Shedding Arrangements

In association with the provision of 4-8-2/3.11, and in order to safeguard continuity of the electrical power supply, automatic load-shedding arrangements or other equivalent arrangements are to be provided:

- i) Where only one generating set is normally used to supply power for propulsion and steering of the vessel, and a possibility exists that due to the switching on of additional loads, whether manually or automatically initiated, the total load exceeds the rated capacity of the running generator, or
- ii) Where electrical power is normally supplied by more than one generator set simultaneously in parallel operation for propulsion and steering of the vessel, upon the failure of one of the parallel running generators, the total connected load exceeds the total capacity of the remaining generator(s).

9.9.2 Services not Allowed for Shedding

Automatic load-shedding arrangements or other equivalent arrangements are not to automatically disconnect the following services. See 4-8-1/7.3.3 for the definition of essential services.

- i)* Primary essential services that, when disconnected, will cause immediate disruption to propulsion and maneuvering of the vessel,
- ii)* Emergency services as listed in 4-8-2/5.5, and
- iii)* Secondary essential services that, when disconnected, will:
 - cause immediate disruption of systems required for safety and navigation of the vessel, such as:
 - Lighting systems,
 - Navigation lights, aids and signals,
 - Internal communication systems required by 4-8-2/11.5, etc.
 - prevent services necessary for safety from being immediately reconnected when the power supply is restored to its normal operating conditions, such as:
 - Fire pumps, and other fire extinguishing medium pumps,
 - Bilge pumps,
 - Ventilation fans for engine and boiler rooms
- iv)* Service operations critical to the safety of the vessel.

9.11 Protection of Generators

9.11.1 Overload Protection

Generators are to be protected by circuit breakers providing long-time delay overcurrent protection not exceeding 15% above either the full-load rating of continuous-rated machines or the overload rating of special-rated machines. Alternatively, generators of less than 25 kW not arranged for parallel operation may be protected by fuses.

9.11.2 Short-circuit Protection

Generators are to be protected for short circuit by circuit breakers provided with short-time delay trips. For coordination with feeder circuit breakers, the short-time delay trips are to be set at the lowest values of current and time which will coordinate with the trip settings of feeder circuit breakers. The current setting of the short time delay trip is to be less than the steady state short-circuit current of the generator.

Where two or more AC generators are arranged for parallel operation, each generator's circuit breaker is, in addition, to be provided with instantaneous trip set in excess of the maximum short-circuit contribution of the individual generator.

Alternative suitable protection, such as generator differential protection, which will trip the generator circuit breaker in the event of a fault in the generator or in the supply cable between the generator and its circuit breaker, would also be acceptable.

For generators of less than 200 kW driven by diesel engines or gas turbines which operate independently of the electrical system, consideration may be given to omission of the short-time delay trips if instantaneous trips and long-time overcurrent protection (see 4-8-2/9.11.1) are provided. When the short time delay trips are omitted, the thermal withstand capacity of the generator is to be greater than the steady state short-circuit current of the generator, until activation of the tripping system.

9.11.3 Thermal Damage Protection

Generator circuit breakers at the main and emergency switchboard are to have tripping characteristics and to be set such that they will open before the generator sustains thermal damages due to the fault current. See 4-8-2/9.7.

9.11.4 Reverse Power Protection

A reverse power protection device is to be provided for each generator arranged for parallel operation. The setting of the protective devices is to be in the range 2% to 6% of the rated power for turbines and in the range 8% to 15% of the rated power for diesel engines.

A setting of less than 8% of the rated power of diesel engines may be allowed with a suitable time delay recommended by the diesel engine manufacturer. A fall of 50% in the applied voltage is not to render the reverse power protection inoperative, although it may alter the setting to open the breaker within the above range.

9.11.5 Prime Mover Shutdown

The shutting down of the prime mover is to cause the tripping of the generator circuit breaker.

9.11.6 Undervoltage Protection

Generators arranged for parallel operation are to be provided with means to prevent the generator circuit breaker from closing if the generator is not generating, and to open the same when the generator voltage collapses.

In the case of an undervoltage release provided for this purpose, the operation is to be instantaneous when preventing closure of the breaker, but is to be delayed for discrimination purposes when tripping a breaker.

9.13 Protection of Feeder Cables

Each feeder conductor is to be protected by a circuit breaker, or fuse with disconnecting switchgear, from short circuit and overload at the supply end.

Fuse ratings and rating of time-delay trip elements of circuit breakers are not to exceed the rated current capacity of the feeder cables, except as otherwise permitted for motor and transformer circuits where starting in-rush current need be taken into account.

If the standard rating or setting of the overload protective device does not correspond to the current rating of the feeder cable, the next higher standard rating or setting may be used, provided it does not exceed 150% of the allowable current carrying capacity of the feeder cable, where permitted by the Standard to which the feeder cables have been constructed.

9.15 Protection for Accumulator Batteries

Accumulator batteries, other than engine starting batteries, are to be protected against overload and short circuits by devices placed as near as practicable to the batteries, but outside of the battery rooms, lockers or boxes, except that the emergency batteries supplying essential services are to have short circuit protection only. Fuses may be used for the protection of batteries for emergency lighting instead of circuit breakers up to and including 320 A rating. The charging equipment, except rectifiers, for all batteries with a voltage of more than 20% of the line voltage is to be provided with reverse current protection.

9.17 Protection of Motor Circuits

Overload and short-circuit protection is to be provided for each motor circuit in accordance with the following requirements.

9.17.1 Motor Branch Circuit Protection

9.17.1(a) General. Motor branch circuits are to be protected with circuit breakers or fuses having both instantaneous and long-time delay trips or with fuses. The setting is to be such that it will permit the passage of starting currents without tripping. Normally, the protective device is to be set in excess of the motor's full load current but not more than the limitations given in the table below. If that rating or setting is not available, the next higher available rating or setting may be used. In cases where the motor branch circuit cable has allowable current capacity in excess of the motor full load current, the protective device setting may exceed the applicable limitation, but not that given in 4-8-2/9.13.

<i>Type of Motor</i>	<i>Rating or Setting, % Motor Full-load Current</i>
Squirrel-cage and synchronous full-voltage, reactor- or resistor-starting	250
Autotransformer starting	200
Wound rotor	150

When fuses are used to protect polyphase motor circuits, they are to be arranged to protect against single-phasing.

9.17.1(b) *Short-circuit protection only.* Where the motor branch circuit is protected with a circuit breaker fitted with instantaneous trip only (e.g., 4-8-2/9.17.5), the motor controller is to have a short-circuit rating matching at least that of the circuit breaker instantaneous trip setting, and the motor overload protection (see 4-8-2/9.17.2) is to be arranged to open all conductors.

9.17.2 Motor Overload Protection

The overload protective devices of motors are to be compatible with the motor overload thermal characteristics, and are to be set at 100% of the motor rated current for continuous rated motor. If this is not practicable, the setting may be increased to, but in no case exceeding, 125% of the motor rated current. This overload protective device may also be considered the overload protection of the motor branch circuit cable.

For athwartship thrusters, a motor overload alarm in the wheelhouse is acceptable in lieu of the overload protection.

9.17.3 Undervoltage Protection

Undervoltage protection is to be provided for motors having power rating exceeding 0.5 kW (0.7 hp) to prevent undesired restarting upon restoration of the normal voltage, after a stoppage due to a low voltage condition or voltage failure condition.

9.17.4 Undervoltage Release Protection

Undervoltage release is to be provided for the following motors unless the automatic restart upon restoration of the normal voltage will cause hazardous conditions:

- i) Primary essential services (see 4-8-1/Table 1).
- ii) Only those secondary essential services (see 4-8-1/Table 2) necessary for safety, such as:
 - Fire pumps and other fire extinguishing medium pumps.
 - Ventilating fans for engine and boiler rooms where their failure to restart may prevent the normal operation of the propulsion machinery (See Note 1 below)

Special attention is to be paid to the starting currents due to a group of motors with undervoltage-release controllers being restarted automatically upon restoration of the normal voltage. Means such as sequential starting is to be provided to limit excessive starting current, where necessary.

Note 1: Undervoltage protection is to be provided for ventilation fans for engine and boiler room, which are supplied by an emergency source of power for the purpose of removing smoke from the space after a fire has been extinguished.

9.17.5 Protection of Steering Gear Circuits

9.17.5(a) *AC motors.* The steering gear feeder is to be provided with short-circuit protection only, which is to be located at the main or emergency switchboard. However, overload protection may be permitted if it is set at a value not less than 200% of the full load current of the motor (or of all the loads on the feeder), and is to be arranged to permit the passage of the starting current.

9.17.5(b) *DC motors.* The feeder circuit breaker on the main switchboard is to be set to trip instantaneously between 300% and 375% of the rated full-load current of the steering-gear motor. The feeder circuit breaker on the emergency switchboard may be set to trip instantaneously between 200% and 375%.

9.17.5(c) *Fuses.* The use of fuses for steering gear motor circuits is not permitted.

9.19 Protection of Transformer Circuits

9.19.1 Protection at Primary Side Only

Each power and lighting transformer along with its feeder is to be provided with short-circuit and overload protection. The protective device is to be installed on the primary side of the transformer and is to be set at 100% of the rated primary current of the transformer. If this setting is not practicable, it may be increased to, but in no case exceeding 125% of the rated primary current.

The instantaneous trip setting of the protective device is not to be activated by the in-rush current of the transformer when switching into service.

9.19.2 Protection at Both Primary and Secondary Sides

Where the secondary side of the transformer is fitted with a protective device set at not more than 125% of the rated secondary current, the transformer primary side protective device may be set at a value less than 250% of the rated primary current.

9.19.3 Parallel Operation

When the transformers are arranged for parallel operation, means are to be provided to disconnect the transformer from the secondary circuit. Where power can be fed into secondary windings, short-circuit protection (i.e., short-time delay trips) is to be provided in the secondary connections. In addition, when the disconnecting device in primary side of the transformer is opened due to any reason (e.g., the short-circuit protection, overload protection, or manual operation for opening), the disconnecting device in the secondary side of the transformer is to be arranged to open the circuit automatically.

9.21 Protection for Branch Lighting Circuits

Branch lighting circuits are to be protected against overload and short circuit. In general, overload protective devices are to be rated or set at not more than 30 A. The connected load is not to exceed the lesser of the rated current carrying capacity of the conductor or 80% of the overload protective device rating or setting.

9.22 Harmonic Distortion for Ship Electrical Distribution System including Harmonic Filters

9.22.1 Monitoring

Where the electrical distribution system on board a ship includes harmonic filters, such ships are to be fitted with facilities to continuously monitor the levels of harmonic distortion experienced on the main bus bar as well as alert the crew should the level of harmonic distortion exceed the acceptable limits. Where the engine room is provided with automation systems, this reading is to be logged electronically, otherwise it is to be recorded in the engine log book for future inspection by the Surveyor. However, harmonic filters installed for single application frequency drives such as pump motors may be excluded from the requirements of this section.

9.22.2 Measurement

As a minimum, harmonic distortion levels of main bus bar on board such existing ships are to be measured annually under seagoing conditions as close to the periodical machinery survey as possible so as to give a clear representation of the condition of the entire plant to the Surveyor. Harmonic distortion readings are to be carried out when the greatest amount of distortion is indicated by the measuring equipment. An entry showing which equipment was running and/or filters in service is to be recorded in the log so this can be replicated for the next periodical survey. Harmonic distortion levels are also to be measured following any modification to the ship's electrical distribution system or associated consumers by suitably trained ship's personnel or from a qualified outside source. Records of all the above measurements are to be made available to the surveyor at each periodical survey in accordance with the *ABS Rules for Survey After Construction (Part 7)*.

9.22.3 Validation of Calculated Harmonic

Where the electrical distribution system on board a ship includes harmonic filters, the system integrator of the distribution system is to show, by calculation, the effect of a failure of a harmonic filter on the level of harmonic distortion experienced.

The system integrator of the distribution system is to provide the ship owner with guidance documenting permitted modes of operation of the electrical distribution system while maintaining harmonic distortion levels within acceptable limits during normal operation as well as following the failure of any combination of harmonic filters.

The calculation results and validity of the guidance provided are to be verified by the Surveyor during sea trials.

9.22.4 Filter Protection Alarm

Arrangements are to be provided to alert the crew in the event of activation of the protection of a harmonic filter circuit.

A harmonic filter is to be arranged as a three-phase unit with individual protection of each phase. The activation of the protection arrangement in a single phase is to result in automatic disconnection of the complete filter. Additionally, there is to be installed a current unbalance detection system independent of the overcurrent protection alerting the crew in case of current unbalance.

Consideration is to be given to additional protection for the individual capacitor element as (e.g., relief valve or overpressure disconnecter) in order to protect against damage from rupturing. This consideration is to take into account the type of capacitors used.

9.23 Protection of Harmonic Filter Circuits Associated with Electric Propulsion

Notwithstanding the requirements of 4-8-2/9.22 above, harmonic filters circuits shall be protected against overload and short-circuit. An alarm is to be initiated in a continuously manned location in the event of an activation of overload or short-circuit protection.

In cases where multiple harmonic filter circuits are used in series or in parallel, current imbalance between the different filter circuits is to be continuously monitored. The total rms current into each phase of a passive harmonic filter circuit is also to be monitored. Detection of a current imbalance shall be alarmed in a continuously manned location. If the current imbalance exceeds the ratings of the individual filter circuit components, the appropriate circuits shall automatically trip and be prevented from interacting with other parts of the electrical network.

Harmonic filters that contain capacitors are to have means of monitoring and of providing advance warning of capacitor(s) deterioration. Harmonic filters containing oil filled capacitors are to be provided with suitable means of monitoring oil temperature or capacitor internal pressure. Refer to 4-7-2/5.11 for additional requirements. Detection of capacitor(s) deterioration shall be alarmed locally at the equipment and in a continuously manned location. Power to the harmonic filter circuit containing the deteriorated capacitor(s) shall be automatically disconnected and the capacitor discharged safely upon detection of deterioration.

In cases where provisions for automatic/manual switching and/or disconnection of harmonic filter circuits are provided, there are to be provisions to prevent transient voltages in the system and to automatically discharge the capacitors in the harmonic filter circuits before they can be put back on-line.

Capacitors used in harmonic filters/capacitor banks are to be prevented from producing a leading system power factor which could potentially lead to generator(s) becoming self-excited. In cases where a leading power factor condition approaches the point of the generator(s) becoming self-excited, the appropriate capacitive circuits shall be automatically disconnected and prevented from interacting with the rest of the electrical network.

11 Specific Systems

11.1 Shore Connection

Where arrangements are made for the supply of electricity from a source onshore or other external source, the following requirements apply.

11.1.1 Connection Box and Cable

A shore connection box is to be provided on the vessel for the reception of the flexible cable from an external source. Fixed cables of adequate rating are to be provided between the shore connection box and the main or emergency switchboard. The cable is to be protected by fuses or a circuit breaker located at the connection box. Where fuses are used, a disconnecting means is also to be provided. Trailing cable is to be appropriately fixed to avoid its imposing excessive stress on the cable terminal.

11.1.2 Interlock Arrangements

An interlocking arrangement is to be provided between all generators, including the emergency generator, and the shore power supply to prevent the shore power from being inadvertently paralleled with the shipboard power in order to safeguard from connecting unlike power sources to the same bus.

11.1.3 Instrumentation

An indicator light is to be provided at the main or emergency switchboard to which shore power is connected to show energized status of the cable. Means are to be provided for checking the polarity (for DC) or the phase sequence (for three-phase AC) of the incoming supply in relation to the vessel's system.

11.1.4 Earth Connection

An earth terminal is to be provided for connecting the hull to an external earth.

11.1.5 Information Plate

An information plate is to be provided at or near the connection box giving full information on the system of supply and the nominal voltage (and frequency if AC) of the vessel's system and the recommended procedure for carrying out the connection.

11.3 Navigation Light System

11.3.1 Feeder

Navigation lights (mast head, side and stern lights) are to be fed by their own exclusive distribution board located on the navigation bridge. The distribution board is to be supplied from the main as well as from the emergency source of power (see 4-8-2/Table 1). A means to transfer the power source is to be fitted on the navigation bridge.

11.3.2 Branch Circuit

Each navigation light is to have its own branch circuit, and each branch circuit is to be fitted with a protective device.

11.3.3 Duplicate Lamp

Each navigation light is to be fitted with duplicate lamps.

11.3.4 Control and Indication Panel

A control and indication panel for the navigation lights is to be provided on the navigation bridge. The panel is to be fitted with the following functions:

- A means to disconnect each navigation light.
- An indicator for each navigation light.
- Automatic visual and audible warning in the event of failure of a navigation light. If a visual signal device is connected in series with the navigation light, the failure of this device is not to cause the extinction of the navigation light. The audible device is to be connected to a separate power supply so that the audible alarm may still be activated in the event of power or circuit failure to the navigation lights.

11.5 Interior Communication Systems

11.5.1 General

Means of communication are to be provided between the navigation bridge and the following interior locations:

- i)* Radio room, if separated from the navigation bridge.
- ii)* Centralized propulsion machinery control station, if fitted.
- iii)* Propulsion machinery local control position.
- iv)* For vessels intended to be operated with unattended propulsion machinery spaces, each engineer's cabin and at least one public space where the alarm monitoring station is provided. See 4-8-2/11.5.3iii) and 4-9-6/19.1.
- v)* Steering gear compartment.
- vi)* Any other positions where the speed and direction of thrust of the propellers may be controlled, if fitted.
- vii)* DP control stations and applicable control stations subject to specialized offshore services, see Part 5D.

11.5.2 Engine Order Telegraph

An engine order telegraph system which provides visual indication of the orders and responses both in the machinery space (the centralized control station, if fitted, otherwise propulsion machinery local control position) and on the navigation bridge is to be provided. For vessels less than 500 GT, an engine order telegraph need not be provided if the propulsion plant is controlled entirely from the navigation bridge with no means of normal engine control from the engine room.

A means of communication is to be provided between the centralized propulsion machinery control station, if fitted, and the propulsion machinery local control position. This can be a common talking means of voice communication and calling or an engine order telegraph repeater at the propulsion machinery local control position

11.5.3 Voice Communication

Means of voice communication are to be provided as follows. A common system capable of serving all of the following will be acceptable.

- i)* A common talking means of voice communication and calling is to be provided among the navigation bridge, centralized control station, if fitted (otherwise the propulsion machinery local control position), and any other position where the speed and direction of thrust of the propellers may be controlled. Simultaneous talking among these positions is to be possible at all times and the calling to these positions is to be always possible, even if the line is busy.
- ii)* A means of voice communication is to be provided between the navigation bridge and the steering gear compartment.
- iii)* For vessels intended to be operated with an unattended propulsion machinery space, the engineers' accommodation is to be included in the communication system in *i)*.
- iv)* For bunkering operations, a means of voice communication is to be provided between the bunkering stations and the machinery spaces controlling and monitoring the receiving and transferring of fuel oil.

11.5.4 Public Address System

A public address system is to be provided to supplement the general emergency alarm system in 4-8-2/11.7.1, unless other suitable means of communication is provided. The system is to comply with the following requirements:

- i)* The system is to have loudspeakers to broadcast messages to muster stations and to all spaces where crew are normally present.

- ii) The system is to be designed for broadcasting from the navigation bridge and at least one other emergency alarm control station situated in at least one other location for use when the navigation bridge is rendered inaccessible due to the emergency [see 4-8-2/11.7.1(f)]. The broadcasting stations are to be provided with an override function so that emergency messages can be broadcast even if any loudspeaker has been switched off, its volume has been turned down, or the public address system is used for other purposes.
- iii) With the vessel under way, the minimum sound pressure level for broadcasting messages in interior spaces is to be 75 dB(A) and at least 20 dB(A) above the corresponding speech interference level, which is to be maintained without action from addressees.
- iv) The system is to be protected against unauthorized use.
- v) Where a single system serves for both public address and general emergency alarm functions, the system is to be arranged so that a single failure is not to cause the loss of both systems and is to minimize the effect of a single failure. The major system components, such as power supply unit, amplifier, alarm tone generator, etc., are to be duplicated. Power supply is to comply with 4-8-2/11.7.1(b) and 4-8-2/11.7.1(c).

For cargo vessels, the coverage provided by the arrangement of the system loops and speakers is to be such that after a single failure, the announcements and alarms are still audible in all spaces. Duplication of system loops and speakers in each room or space is not required provided the announcements and alarms are still audible in all spaces.

For passenger vessels, a single system serving for both public address and general emergency alarm functions would still be required to have at least two loops sufficiently separated throughout their length with two separate and independent amplifiers. See 5C-7-5/13.15ii).

11.5.5 Power Supply

The above communication systems are to be supplied with power (not applicable to sound powered telephones) from the emergency switchboard. The final power supply branch circuits to these systems are to be independent of other electrical systems.

For sound powered telephone systems where the calling device or any peripheral devices are electrically powered, the above requirements are applicable to the electrically powered devices.

11.7 Manually Operated Alarms

11.7.1 General Emergency Alarm System

Each vessel over 100 GT is to be fitted with a general emergency alarm system for purpose of summoning crew to the muster stations is to be provided. The system is to be supplemented by a public address system in 4-8-2/11.5.4 or other suitable means of communication. Any entertainment sound system is to be automatically turned off when the general alarm system is activated. The system is to comply with the following requirements:

11.7.1(a) The system is to be capable of sounding the general emergency alarm signal consisting of seven or more short blasts followed by one long blast on the vessel's whistle or siren and, additionally, on an electrically operated bell or klaxon or other equivalent system, which is to be powered from the vessel's main supply and the emergency source of power.

11.7.1(b) There are to be not less than two sources of power supply for the electrical equipment used in the operation of the general emergency alarm system, one of which is to be from the emergency switchboard and the other from the main switchboard. The supply is to be provided by separate feeders reserved solely for that purpose. Such feeders are to run to an automatic change-over switch without passing through any other distributing switchboard. The automatic change-over switch is to be situated in, or adjacent to, the main general emergency alarm control panel.

11.7.1(c) An alarm is to be provided in a normally manned control station to indicate when there is a loss of power in any one of the feeders required by 4-8-2/11.7.1(b).

11.7.1(d) As an alternative to two feeders as described in 4-8-2/11.7.1(b), a battery may be considered as one of the required sources, provided the battery has the capacity of at least 30 minutes of continuous operation for alarming and 18 hours in standby. A low voltage alarm for the battery and the battery charger output is to be provided. The battery charger is to be supplied from the emergency switchboard.

11.7.1(e) The system is to be audible throughout all of the accommodation and normal crew working spaces. The alarm is to continue to function after it has been triggered until it is manually turned off or is temporarily interrupted by a message on the public address system.

11.7.1(f) The system is to be capable of operation from the navigation bridge and, except for the vessel's whistle, also from at least one other strategic location from which emergency situations are intended to be controlled. Fire control station, muster station, or cargo control station, etc. are examples of spaces that may be regarded as strategic locations, provided they are fitted with the means of operating the general alarm system. Attention is drawn to the Flag Administration, which may require additional stations.

11.7.1(g) The minimum sound pressure level for the emergency alarm tone in interior spaces is to be 80 dB(A) and 10 dB(A) above ambient noise level existing during normal equipment operation with the vessel under way in moderate weather.

11.7.1(h) The sound pressure level at the sleeping position in cabins and in cabin bathrooms is to be at least 75 dB(A) and at least 10 dB(A) above ambient noise level.

Reference is to be made to IMO Resolution A.1021(26) *Codes on Alarms and Indicators, 2009*.

11.7.2 Engineers' Alarm

On vessels of 500 gross tons and over, intended for international voyages or unrestricted ocean services, an engineers' alarm operable at the centralized propulsion machinery control station, the propulsion machinery local control position or offshore service operation control station, as appropriate, is to be provided. It is to be clearly audible in each engineer's cabin, and the sound pressure level is to comply with 4-8-2/11.7.1.

11.7.3 Refrigerated Space Alarm

Each refrigerated space is to be fitted with means to activate an audible and visual alarm in a normally manned control station, operable from within such spaces for the protection of personnel.

11.7.4 Elevator's Alarm

Each elevator car is to be fitted with means to activate an alarm in a normally manned control station or with means of voice communication with that station.

11.7.5 Power Supply

The alarm systems in 4-8-2/11.7.2, 4-8-2/11.7.3 and 4-8-2/11.7.4 are to be supplied with power from the emergency switchboard. The final power supply branch circuits to the alarm systems in 4-8-2/11.7.1 and 4-8-2/11.7.2 are to be independent of other electrical systems.

11.9 Emergency Shutdown Systems

11.9.1 Ventilation Systems

11.9.1(a) *Propulsion machinery spaces.* Power ventilation systems serving these spaces are to be fitted with means for stopping the ventilation fan motors in the event of fire. The means for stopping the power ventilation serving these spaces is to be entirely separate from the means for stopping the ventilation of spaces in 4-8-2/11.9.1(b), 4-8-2/11.9.1(c) and 4-8-2/11.9.1(d). See 4-7-2/1.9.5.

11.9.1(b) *Machinery spaces other than propulsion machinery spaces.* Power ventilation systems serving these spaces are to be fitted with means for stopping the ventilation fan motors in the event of fire. The means for stopping the power ventilation serving these spaces is to be entirely separate from the means for stopping the ventilation of spaces in 4-8-2/11.9.1(a), 4-8-2/11.9.1(c) and 4-8-2/11.9.1(d). See 4-7-2/1.9.5.

11.9.1(c) Cargo spaces. Electrical ventilation systems installed in cargo spaces are to be fitted with remote means of control so that the ventilation fan motors can be stopped in the event of a fire in the cargo space. These means are to be outside the cargo spaces and in a location not likely to be cut off in the event of a fire in the cargo spaces. Particular attention is to be directed to specific requirements applicable to the ventilation systems of cargo spaces of each vessel type provided in Part 5C.

11.9.1(d) Accommodation spaces, service spaces, control stations and other spaces. A control station for all other power ventilation systems is to be located on the navigation bridge, in firefighting station, if fitted, or in an accessible position leading to, but outside of, the space ventilated. See 4-7-2/3.7.3.

11.9.2 Fuel Oil, Lubricating Oil and Thermal Oil Systems

Fuel oil transfer pumps, fuel oil unit pumps and other similar fuel pumps, lubricating oil service pumps, thermal oil circulating pumps and oil separators (purifiers, but not including oily water separators) are to be fitted with remote means of stopping. These means are to be located outside the space where these pumps and separators are installed or at the firefighting station, if fitted, so that they may be stopped in the event of a fire arising in that space.

11.9.3 Forced-draft Fans

Forced- or induced-draft fans for boilers, incinerators, thermal oil heaters and similar fired equipment are to be fitted with remote means of stopping. These means are to be located outside the space in which this equipment is located or at the fire fighting station, if fitted, so that the fans may be stopped manually in the event of a fire arising in that space.

11.9.4 Unattended Machinery Spaces

For vessels intended to be operated with an unattended propulsion machinery space, the emergency shutdowns of equipment in 4-8-2/11.9.1 through 4-8-2/11.9.3, associated with the propulsion machinery space, are to be located in the fire-fighting station, as required by 4-9-6/21.3.

11.11 Battery Starting Systems

11.11.1 Propulsion Engine

Where the propulsion engine is arranged for electric starting, at least two separate batteries (or separate set of batteries) are to be fitted. The arrangement is to be such that the batteries (or set of batteries) cannot be connected simultaneously in parallel and each battery (or set) is to be capable of starting the propulsion engine. The combined capacity of the batteries is to be sufficient without recharging to provide within 30 minutes the number of starts of the propulsion engines required for the starting in 4-6-5/9.5.1, and, if arranged, also to supply starting for the auxiliary engine, the number of starts require in 4-8-2/11.11.2.

11.11.2 Auxiliary Engines

Electric starting arrangements for auxiliary engines are to have at least two separate batteries (or separate set of batteries) or may be supplied by separate circuits from the propulsion engine batteries, when such are provided. Where one auxiliary engine is arranged for electric starting, one battery (or set) may be accepted in lieu of two separate batteries (or sets). The capacity of the batteries for starting the auxiliary engines is to be sufficient for at least three starts for each engine.

11.11.3 Miscellaneous Requirements

The starting batteries (or set of batteries) are to be used for starting and for the engine's own control and monitoring purpose only. When the starting batteries are used for the engine's own control and monitoring purpose, the aggregate capacity of the batteries is to be sufficient for continued operation of such a system in addition to the required number of starting capacity. Provisions are to be made to continuously maintain the stored energy at all times. Battery systems for engine starting may be of the one-wire type and the earth lead is to be carried to the engine frame.

4

CHAPTER 8 Electrical Systems

SECTION 3 Electrical Equipment

1 General

1.1 Application

The provisions of this section apply to all equipment, in general. Additional requirements applicable to high voltage systems and electric propulsion systems are given in Section 4-8-5. For DC systems, unless specifically stated in this Section and 4-8-5/7, see IEC Publications 60092-201, 60092-202 and 60092-301. Requirements applicable to specific vessel types, particularly with regard to equipment in hazardous areas, are given in Part 5C and Part 5D.

1.3 Standard of Compliance

In general, electrical equipment is to be designed, constructed and tested to a national, international or other recognized standard and in accordance with requirements of this section.

1.5 Certification of Equipment

The electrical equipment indicated below are required to be certified by ABS for complying with the appropriate provisions of this section (see also 4-1-1/Table 3):

- Generators and motors of 100 kW (135 hp) and over intended for essential services (see definition in 4-8-1/7.3.3) or for services indicated in 4-8-3/Table 7. See 4-8-3/3.
- Main, propulsion and emergency switchboards. See 4-8-3/5.
- Motor controllers of 100 kW (135 hp) and over intended for essential services or for services indicated in 4-8-3/Table 7. See 4-8-3/5.7.
- Motor control centers with aggregate load of 100 kW (135 hp) and over intended for essential services or for services indicated in 4-8-3/Table 7. See 4-8-3/5.7.
- Semiconductor converters used to control motor drives having a rated power of 100 kW(135 hp) and over intended for essential services or for services indicated in 4-8-3/Table 7. See 4-8-3/8.
- Battery charging and discharging boards of 25 kW and over for emergency and transitional source of power. See 4-8-3/5.9.
- Uninterruptible power system (UPS) units of 50 kVA and over. See 4-8-3/5.9.
- Propulsion controls, propulsion semiconductors and propulsion cables. See 4-8-3/9 and 4-8-5/5.11.3, 4-8-5/5.17.8 and 4-8-5/5.17.11.

Other electrical equipment items are to be designed, constructed and tested in accordance with established industrial practices, manufacturer's specifications and applicable requirements in this Section. Acceptance will be based on manufacturer's documentation which is to be made available upon request and on satisfactory performance after installation. Mass produced items may, at the discretion of the manufacturers, be certified under the Type Approval Program, Appendix 1-1-A3 of the *ABS Rules for Conditions of Classification (Part 1)* and 4-1-1/Table 3.

1.7 Materials and Design

Electrical equipment is to be constructed of durable, flame-retardant, moisture resistant materials, which are not subject to deterioration in the marine environment and at the temperatures to which it is likely to be exposed.

Electrical equipment is to be designed such that current-carrying parts with potential to earth are protected against accidental contact.

1.9 Voltage and Frequency Variations

The electrical equipment supplied from the main or emergency systems are to be capable of being operated satisfactorily under normally occurring variations in voltage and frequency. Unless otherwise specified in national or international standards, the following variations from the rated value are to be assumed:

<i>Voltage and Frequency Variations for AC Distribution Systems</i>		
<i>Quantity in Operation</i>	<i>Permanent Variation</i>	<i>Transient Variation (Recovery Time)</i>
Frequency	±5%	±10% (5 s)
Voltage	+6%, -10%	±20% (1.5 s)

<i>Voltage Variations for DC Distribution Systems (such as systems supplied by DC generators or rectifiers)</i>	
<i>Parameters</i>	<i>Variations</i>
Voltage tolerance (continuous)	±10%
Voltage cyclic variation deviation	5%
Voltage ripple (AC rms over steady DC voltage)	10%

<i>Voltage Variations for Battery Systems</i>	
<i>Type of System</i>	<i>Variations</i>
Components connected to the battery during charging (see Note)	+30%, -25%
Components not connected to the battery during charging	+20%, -25%

Note: Different voltage variations as determined by the charging/discharging characteristics, including the ripple voltage from the charging device, may be considered.

Any special system, such as electronic circuits, whose function cannot operate satisfactorily within the limits shown in the above tables, is not to be supplied directly from the system but by alternative means, such as through a stabilized supply.

For generators, see 4-8-3/3.13.1(a), 4-8-3/3.13.1(b) and 4-8-3/3.13.2.

1.11 Enclosures

1.11.1 General

Electrical equipment is to have a degree of enclosure for protection against the intrusion of foreign objects and liquids, appropriate for the location in which it is installed. The minimum degree of protection is to be in accordance with 4-8-3/Table 2.

For the purpose of defining protection levels used in 4-8-3/Table 2, the following conventions apply. The degree of protection by an enclosure with respect to the intrusion of foreign particles and water is defined by the designation 'IP' followed by two digits: the first digit signifies the protection degree against particles, and the second digit signifies the protection degree against water. For complete details, see 4-8-3/Table 1A and 4-8-3/Table 1B. These designations are identical to that specified in IEC Publication 60529. For high voltage equipment see 4-8-5/Table 1.

1.11.2 Equipment in Areas Affected by Local Fixed Pressure Water-spraying or Local Water-mist Fire Extinguishing System in Machinery Spaces

Electrical and electronic equipment within areas affected by Local Fixed Pressure Water-spraying or Local Water-mist Fire Extinguishing Systems are to be suitable for use in the affected area. See 4-8-3/Figure 1. Where enclosures have a degree of protection lower than IP44, evidence of suitability for use in these areas is to be submitted to ABS taking into account:

- i) The actual Local Fixed Pressure Water-spraying or Local Water-mist Fire Extinguishing system being used and its installation arrangements, and
- ii) The equipment design and layout (e.g., position of inlet ventilation openings, filters, baffles, etc.) to prevent or restrict the ingress of water mist/spray into the equipment. The cooling airflow for the equipment is to be maintained.

Note:

Additional precautions may be required to be taken with respect to:

- a. Tracking as the result of water entering the equipment
- b. Potential damage as the result of residual salts from sea water systems
- c. High voltage installations
- d. Personnel protection against electric shock

Equipment may require maintenance after being subjected to water mist/spray.

FIGURE 1
Example of Area Affected by Local Fixed Pressure Water-spraying or Local Water-mist Fire Extinguishing System in Machinery Spaces

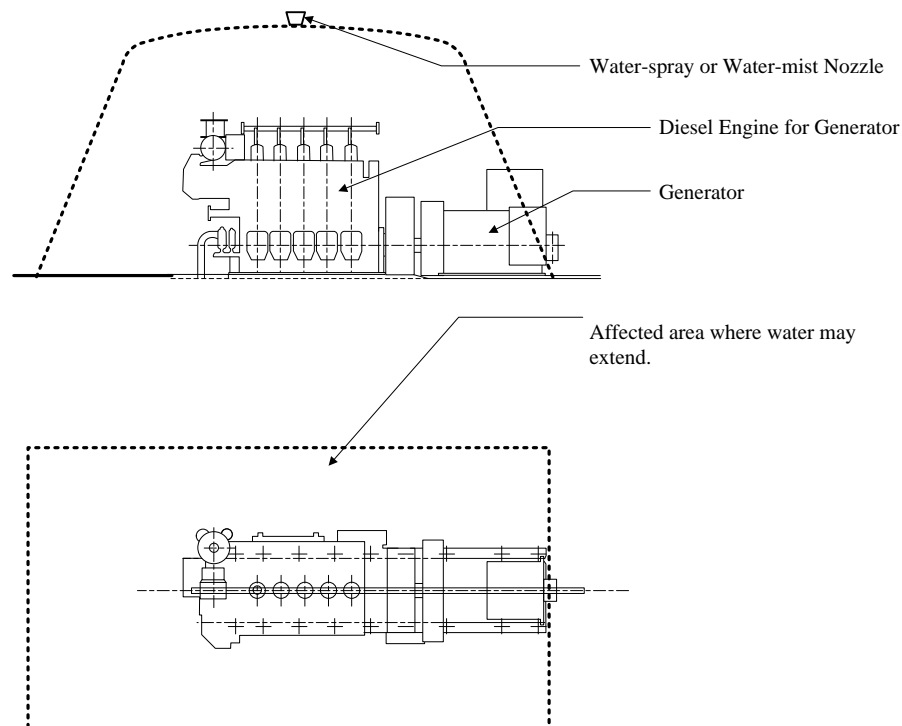

1.13 Accessibility

Electrical equipment is to be designed and arranged with a view to provide accessibility to parts requiring inspection or adjustment.

1.15 Insulation Material

Insulating materials are to be classified by their maximum continuous operating temperatures in accordance with the following table:

Class	Maximum Continuous Temperature	
	°C	°F
A	105	221
E	120	248
B	130	266
F	155	311
H	180	356

Materials or combinations of materials which by experience or accepted tests can be shown to be capable of satisfactory operation at temperature over 180°C (356°F) will also be considered. In this regard, supporting background information, reports, tests conducted, etc., ascertaining their suitability for the intended application and operating temperature are to be submitted for review.

1.17 Ambient Temperatures

1.17.1 General

For purposes of rating of equipment, a maximum ambient air temperature of 45°C (113°F) is to be assumed.

Where ambient temperatures in excess of 45°C (113°F) are expected, the rating of equipment is to be based on the actual maximum ambient air temperature.

The use of lower ambient temperatures may be considered provided the total rated temperature of the equipment is not exceeded and where the lower values can be demonstrated. The use of a value for ambient temperature less than 40°C (104°F) is only permitted in spaces that are environmentally controlled.

1.17.2 Reduced Ambient Temperature for Electrical Equipment in Environmentally Controlled Spaces

1.17.2(a) Environmentally-controlled Spaces. Where electrical equipment is installed within environmentally-controlled spaces, the ambient temperature for which the equipment is to be rated may be reduced from 45°C and maintained at a value not less than 35°C, provided:

- i) The equipment is not to be used for emergency services.
- ii) Temperature control is achieved by at least two independent cooling systems so arranged that in the event of loss of one cooling system for any reason, the remaining system(s) is capable of satisfactorily maintaining the design temperature. The cooling equipment is to be rated for a 45°C ambient temperature.
- iii) The equipment is to be able to initially start to work safely at a 45°C ambient temperature until such a time that the lesser ambient temperature may be achieved.
- iv) Audible and visual alarms are provided, at a continually-manned control station, to indicate any malfunction of the cooling systems.

1.17.2(b) Rating of Cables. In accepting a lesser ambient temperature than 45°C, it is to be ensured that electrical cables for their entire length are adequately rated for the maximum ambient temperature to which they are exposed along their length.

1.17.2(c) Ambient Temperature Control Equipment. The equipment used for cooling and maintaining the lesser ambient temperature is to be classified as a secondary essential service, in accordance with 4-8-1/7.3, and the capability of cooling is to be witnessed by the Surveyor at sea trial.

3 Rotating Machines

3.1 Application

All generators and motors of 100 kW (135 hp) and over intended for essential services (see 4-8-1/7.3.3) or for services indicated in 4-8-3/Table 7 are to be designed, constructed and tested in accordance with the requirements of 4-8-3/3.

All other rotating electrical machines are to be designed, constructed and tested in accordance with established industrial practices and manufacturer's specifications. Manufacturer's tests for rotating electrical machines less than 100 kW (135 hp) for essential services or for services indicated in 4-8-3/Table 7 are to include at least the tests described in 4-8-3/3.15.2 through 4-8-3/3.15.11, regardless of the standard of construction. The test certificates are to be made available when requested by the Surveyor. Acceptance of machines will be based on satisfactory performance after installation.

3.3 Definitions

3.3.1 Periodic Duty Rating

The periodic duty rating of a rotating machine is the rated kW load at which the machine can operate repeatedly, for specified period (N) at the rated load followed by a specified period (R) of rest and de-energized state, without exceeding the temperature rise given in 4-8-3/Table 4; where $N + R = 10$ minutes, and cyclic duty factor is given by $N/(N + R)$ %.

3.3.2 Short-time Rating

The short-time rating of a rotating electrical machine is the rated kW load at which the machine can operate for a specified time period without exceeding the temperature rise given in 4-8-3/Table 4. A rest and de-energized period sufficient to re-establish the machine temperature to within 2°C (3.6°F) of the coolant prior to the next operation is to be allowed. At the beginning of the measurement, the temperature of the machine is to be within 5°C (9°F) of the coolant.

3.3.3 Non-periodic Duty Rating

The non-periodic duty rating of a rotating electrical machine is the kW load which the machine can operate continuously, for a specific period of time, or intermittently under the designed variations of the load and speed within the permissible operating range, respectively; and the temperature rise, measured when the machine has been run until it reaches a steady temperature condition, is not to exceed those given in 4-8-3/Table 4.

3.3.4 Continuous Rating

The continuous rating of a rotating electrical machine is the rated kW load at which the machine can continuously operate without exceeding the steady state temperature rise given in 4-8-3/Table 4.

3.5 Rating

Generators are to be of continuous rating. Motors are to be of continuous rating unless utilized on an application which definitely imposes an intermittent duty on the motor.

For maximum ambient temperatures to be used when rating rotating machines, see 4-8-3/1.17.

To satisfy the requirements of 4-8-3/3.1, the required power output of gas turbine prime movers for ship's service generator sets is to be based on the maximum expected inlet air temperature.

3.7 Overload/Overcurrent Capability

Overload/overcurrent capabilities for AC and DC generators and motors are to be in accordance with IEC Publication 60034-1. For convenience, the following requirements for AC generators and motors are provided.

3.7.1 AC Generators

AC generators are to be capable of withstanding a current equal to 1.5 times the rated current for not less than 30 seconds. The test may be performed in conjunction with the short-circuit testing, provided the electrical input energy to the machine is not less than that required for the above overload capability.

3.7.2 AC Motors

3.7.2(a) *Overcurrent capacity.* Three phase induction motors having rated output not exceeding 315 kW (422 hp) and rated voltage not exceeding 1 kV are to be capable of withstanding a current equal to 1.5 times the rated current for not less than 2 minutes. For three phase induction motors having rated outputs above 315 kW (422 hp), the overcurrent capacity is to be in accordance with the manufacturer's specification. The test may be performed at a reduced speed.

3.7.2(b) *Overload capacity for induction motors.* Three phase induction motors, regardless of duty, are to be capable of withstanding for 15 seconds without stalling, or abrupt change in speed, an excess torque of 60% above the rated torque, the voltage and frequency being maintained at the rated values. For windlass motors, see 4-5-1/5.1.3.

3.7.2(c) *Overload capacity for synchronous motors.* Three phase synchronous motors, regardless of duty, are to be capable of withstanding an excess torque as specified below for 15 seconds without falling out of synchronism, the excitation being maintained at the value corresponding to the rated load:

- Synchronous (wound rotor) induction motors: 35% excess torque.
- Synchronous (cylindrical rotor) motors: 35% excess torque.
- Synchronous (salient pole) motors: 50% excess torque.

Synchronous motors fitted with automatic excitation are to meet the same excess torque values with the excitation equipment operating under normal conditions.

3.9 Short-circuit Capability

Short-circuit capabilities of generators are to be in accordance with IEC Publication 60034-1. Under short-circuit conditions, generators are to be capable of withstanding the mechanical and thermal stresses induced by a short-circuit current of at least three times the full load current for at least 2 seconds.

3.11 Construction

3.11.1 Shafting

3.11.1(a) *Rotors of non-integrated auxiliary machinery.* The design of the following specified rotating shafts and components, when not integral with the propulsion shafting, are to comply with the following:

- Rotor shaft: 4-2-4/5.3.1 and 4-2-4/5.3.2
- Hollow shaft: 4-3-2/5.3
- Key: 4-3-2/5.7 and 4-2-4/5.3.2
- Coupling flanges and bolts: 4-3-2/5.19

3.11.1(b) *Rotors of integrated auxiliary machinery.* The shaft diameters of the shaft motors and shaft generators, which are an integral part of the line shafting, are to be evaluated per 4-3-1/5.9.1, 4-3-1/5.9.6i), and 4-3-1/5.9.6ii), for maximum torsional moment (steady and vibratory) acting within the operating speeds, instead of torsional moment T at rated speed.

The shaft diameter of the motors and generators, that are an integral part of the line shafting, may also be designed per 4-3-2/5 and are to be evaluated based on engineering analyses per 4-3-2/1.1.

3.11.2 Shaft Circulating Current

Means are to be provided to prevent circulating currents from passing between the journals and the bearings, where the design and arrangement of the machine is such that damaging current may be expected, due to the unbalance of magnetic fields. Where such protection is required, a warning plate is to be provided in a visible, stationary location cautioning against the removal of such protection.

3.11.3 Lubrication

Rotating machine's shaft bearings are to have the required lubrication at all rated operating conditions, and with the vessel inclined as specified in 4-1-1/7.9. Where forced lubrication is employed, generators are to be fitted with means to shut down their prime movers automatically upon failure of the generator's lubricating system. Each self-lubricating sleeve bearing is to be fitted with a means for visual indication of oil level.

3.11.4 Cooling

Where water cooling is used, the cooler is to be so arranged to avoid entry of water into the machine, whether through leakage or condensation in the heat exchanger.

3.11.5 Moisture Condensation Prevention

All generators, and each propulsion motor, are to be provided with a means to prevent moisture condensation in the machine when idle.

Motors, rated 50 kW and over, used for essential services and located in damp spaces or exposed to weather are to be provided with a means to prevent moisture condensation in the machine when idle.

3.11.6 Stator Temperature Detection

AC propulsion generators and motors rated above 500 kW (670 hp) are to be provided with a means of obtaining the temperatures at each phase of the stationary windings.

3.11.7 Enclosure and Terminal Box

Cable terminal boxes are to be fitted with means to secure the cables. Enclosures of rotating machines including the cable terminal boxes are to be such as to eliminate mechanical injury and the risk of damage from water, oil and shipboard atmosphere. The minimum degree of protection is to be in accordance with 4-8-3/Table 2.

Terminals are to be provided at an accessible position and protected against mechanical damage and accidental contact for earthing, short-circuit or touching. Terminal leads are to be secured to the frame and the designation of each terminal lead are to be clearly marked. Terminal leads are to be terminated securely with a vibration resistant means of termination. Cable glands or similar are to be provided where cable penetrations may compromise the protection property of terminal enclosures.

3.11.8 Nameplate Data

Nameplates of corrosion-resistant material are to be provided and are to indicate at least the following, as applicable:

The manufacturer's serial number (or identification mark)	The manufacturer's name
Type of machine	The year of manufacture
Rating	Degree of protection by IP code
The rated voltage	The rated output
The rated speed	The rated current
The rated ambient temperature	The class of insulation
The rated frequency	Number of phase
Type of winding connections	The rated power factor
Rated exciter current	Rated exciter voltage

3.13 Generator Control

3.13.1 Operating Governors

An operating governor is to be fitted to each prime mover driving main or emergency generator and is to be capable of automatically maintaining the speed within the following limits.

3.13.1(a) Steam or gas turbine prime movers:

i) The transient frequency variations in the electrical network when running at the indicated loads below is to be within $\pm 10\%$ of the rated frequency when:

- Running at full load (equal to rated output) of the generator and the maximum electrical step load is suddenly thrown off;

In the case when a step load equivalent to the rated output of a generator is thrown off, a transient frequency variation in excess of 10% of the rated frequency may be acceptable, provided the overspeed protective device, fitted in addition to the governor, as required by 4-2-3/7.1 or 4-2-4/7.1, is not activated.

- Running at no load and 50% of the full load of the generator is suddenly thrown on, followed by the remaining 50% after an interval sufficient to restore the frequency to steady state.

In all instances, the frequency is to return to within $\pm 1\%$ of the final steady state condition in no more than five (5) seconds.

- ii) The permanent frequency variation is to be within $\pm 5\%$ of the rated frequency at any load between no load and the full load.
- iii) For gas turbines driving emergency generators, the requirements of 4-8-3/3.13.1(a)i and 4-8-3/3.13.1(a)ii above are to be met. However, for purpose of 4-8-3/3.13.1(a)i, where the sum of all loads that can be automatically connected is larger than 50% of the full load of the emergency generator, the sum of these loads is to be used.

3.13.1(b) Diesel engine prime mover:

- i) The transient frequency variations in the electrical network when running at the indicated loads below is to be within $\pm 10\%$ of the rated frequency when:

- Running at full load (equal to rated output) of the generator and the maximum electrical step load is suddenly thrown off:

In the case when a step load equivalent to the rated output of a generator is thrown off, a transient frequency variation in excess of 10% of the rated frequency may be acceptable, provided the overspeed protective device, fitted in addition to the governor, as required by 4-2-1/7.5.3, is not activated.

- Running at no load and 50% of the full load of the generator is suddenly thrown on, followed by the remaining 50% after an interval sufficient to restore the frequency to steady state.

In all instances, the frequency is to return to within $\pm 1\%$ of the final steady state condition in no more than five (5) seconds. Consideration can be given to alternative methods of load application as provided in 4-2-1/7.5.1(b) for electrical systems fitted with power management systems and sequential starting arrangements.

- ii) The permanent frequency variation is to be within $\pm 5\%$ of the rated frequency at any load between no load and the full load.
- iii) For emergency generators, the requirements of 4-8-3/3.13.1(b)i and 4-8-3/3.13.1(b)ii above are to be met. However, for the purpose of 4-8-3/3.13.1(b)i, where the sum of all loads that can be automatically connected is larger than 50% of the full load of the emergency generator, the sum of these loads is to be used.

3.13.2 Automatic Voltage Regulation System

The following requirements are for AC generators. For DC generators, refer to IEC Publications 60092-202 and 60092-301.

3.13.2(a) *General.* An automatic voltage regulator is to be fitted for each generator. Excitation current for generators is to be provided by attached rotating exciters or by static exciters deriving their source of power from the machines being controlled.

3.13.2(b) *Variation from rated voltage – steady state.* The automatic voltage regulator is to be capable of maintaining the voltage under steady conditions within $\pm 2.5\%$ of the rated voltage for all loads between zero and the rated load at the rated power factor, taking the governor characteristics of generator prime movers into account. These limits may be increased to $\pm 3.5\%$ for generators for emergency services.

3.13.2(c) *Variation from rated voltage – transient.* Momentary voltage variations are to be within the range of -15% to $+20\%$ of the rated voltage, and the voltage is to be restored to within $\pm 3\%$ of the rated voltage in not more than 1.5 seconds when:

- A load equal to the starting current of the largest motor or a group of motors, but in any case, at least 60% of the rated current of the generator, and power factor of 0.4 lagging or less, is suddenly thrown on with the generator running at no load; and
- A load equal to the above is suddenly thrown off.

Subject to ABS approval, such voltage regulation during transient conditions may be calculated values based on the previous type test records, and need not to be tested during factory testing of a generator.

Consideration may be given to performing the test required by 4-8-3/3.15.4 according to precise information concerning the maximum values of the sudden loads instead of the values indicated above, provided precise information is available. The precise information concerning the maximum values of the sudden loads is to be based on the power management system arrangements and starting arrangements provided for the electrical system.

3.13.2(d) Short-circuit condition. Under short-circuit conditions, the excitation system is to be capable of maintaining a steady-state short-circuit current of not less than three times its rated full load current for 2 seconds or for such magnitude and duration as required to properly actuate the electrical protective devices. See 4-8-3/3.9.

In order to provide sufficient information for determining the discrimination settings in the distribution system where the generator is going to be used, the generator manufacturer is to provide documentation showing the transient behavior of the short circuit current upon a sudden short-circuit occurring when excited, and running at nominal speed. The influence of the automatic voltage regulator is to be taken into account, and the setting parameters for the voltage regulator are to be noted together with the decrement curve. Such a decrement curve is to be available when the setting of the distribution system's short-circuit protection is calculated. The decrement curve need not be based on physical testing. The manufacturer's simulation model for the generator and the voltage regulator may be used where this has been validated through the previous type test on the same model.

3.13.3 Parallel Operation

3.13.3(a) General. When it is intended that two or more generators be operated in parallel, means are to be provided to divide the reactive power equally between the generators in proportion to the generator capacity.

3.13.3(b) Reactive load sharing. The reactive loads of the individual generating sets are not to differ from their proportionate share of the combined reactive load by more than 10% of the rated reactive output of the largest generator, or 25% of the smallest generator, whichever is the less.

3.13.3(c) kW load sharing. In the range between 20% and 100% of the sum of the rated output (aggregate output) of all generators, the load on any generator is not to differ more than $\pm 15\%$ of the rated output kW of the largest generator, or 25% of the rated output kW of the individual generator, whichever is the less, from its proportionate share of the combined load for any steady state condition. The starting point for the determination of the foregoing load-distribution requirements is to be at 75% of the aggregate load with each generator carrying its proportionate share.

3.15 Testing

3.15.1 Machines to be Tested and Test Schedule

3.15.1(a) Machines of 100 kW and Over. Each design of generator and motor of 100 kW (135 hp) and over, intended for essential services (see 4-8-1/7.3.3), or for services indicated in 4-8-3/Table 7, is to be assessed by testing in accordance with the "type tests" schedule indicated in 4-8-3/Table 3. Each subsequent production unit of an accepted design is to be tested in accordance with the "routine tests" schedule indicated also in 4-8-3/Table 3.

3.15.1(b) Machines Below 100 kW. All rotating machines of less than 100 kW intended for essential services or for services indicated in 4-8-1/7.3.3, or for services indicated in 4-8-3/Table 7, are to be tested in accordance with 4-8-3/Table 3 (item 2 through item 10 and item 12). The tests may be carried out by the manufacturer whose certificate of tests will be acceptable and is to be submitted upon request from ABS.

3.15.1(c) *Other Machines.* For machines not intended for essential services or for services indicated in 4-8-3/Table 7, the tests may be carried out by the manufacturer whose certificate of tests will be acceptable and is to be submitted upon request from ABS.

3.15.1(d) *Special Testing Arrangements.* In cases where all of the required tests are not carried out at the plant of the manufacturer, the Surveyor is to be notified and arrangements are to be made so that the remaining tests will be witnessed.

3.15.2 Insulation Resistance Measurement

The resistance is to be measured before the commencement of the testing and after completion of the testing for all circuits. Circuits or groups of circuits of different voltages above earth are to be tested separately.

Immediately after the high voltage tests, the insulation resistance is to be measured using a direct current insulation tester between:

- i) All current carrying parts connected together and earth;
- ii) All current carrying parts of different polarity or phase, where both ends of each polarity or phase are individually accessible.

The minimum values of test voltage and corresponding insulation resistance are given in the table below. The insulation resistance is to be measured close to the operating temperature. If this is not possible, an approved method of calculation is to be used.

Rated Voltage, U_n (V)	Minimum Test Voltage (V)	Minimum Insulation Resistance (M Ω)
$U_n \leq 250$	$2U_n$	1
$250 < U_n \leq 1000$	500	1
$1000 < U_n \leq 7200$	1000	$U_n/1000 + 1$
$7200 < U_n \leq 15000$	5000	$U_n/1000 + 1$

3.15.3 Winding Resistance Measurement

The resistance of the machine winding is to be measured and recorded, using an appropriate bridge method or voltage and current method.

3.15.4 Verification of Voltage Regulation System

Tests are to be conducted on generators to verify that the automatic voltage regulation system is capable of achieving the performance described in 4-8-3/3.13.2.

3.15.5 Rated Load Test and Temperature Rise Measurements

The temperature rises are to be measured after running at the output, voltage, frequency and duty for which the machine is rated. The limits of temperature rise are to be as specified in 4-8-3/Table 4.

3.15.6 Overload/Overcurrent Tests

Tests are to be conducted on generators and motors to demonstrate that their overload/overcurrent capabilities are as described in 4-8-3/3.7.

3.15.7 Short-circuit Capability Tests

Tests are to be conducted on AC generators to demonstrate that the generator and its automatic voltage regulation system are capable of sustaining without damage, under steady-state short-circuit condition, a current of three times the rated current for 2 seconds. See 4-8-3/3.9 and 4-8-3/3.13.2(d).

3.15.8 Overspeed Test

AC generators and, where specified and agreed upon between purchaser and manufacturer, AC motors are to withstand without damage a test run at 1.2 times the rated speed for at least 2 minutes. This test is not applicable to squirrel cage motors.

Where specified and agreed upon between purchaser and manufacturer, DC generators and motors are to withstand a test run without damage for the following overspeed tests for at least 2 minutes:

<i>DC Machine Type</i>	<i>Overspeed Requirements</i>
Generators	1.2 times the rated speed
Shunt-wounded and separately excited motors	1.2 times the highest rated speed, or 1.15 times the corresponding no-load speed, whichever is the greater
Compound-wounded motors having speed regulation of 35% or less	1.2 times the higher rated speed, or 1.15 times the corresponding no-load speed, whichever is the greater, but not exceeding 1.5 times the highest rated speed
Compound-wounded motors having speed regulation greater than 35% or and series-wounded motors	The manufacturer is to assign a maximum safe operating speed which is to be marked on the rating plate. The overspeed for these motors is to be 1.1 times the maximum safe operating speed.

3.15.9 Dielectric Strength Test

The dielectric strength of all rotating machines is to be tested with all parts assembled and in a condition equivalent to a normal working condition. The following requirements apply to those machines, other than high voltage systems covered by 4-8-5/3.13.1. The test voltage is to be applied between the windings under test and the frame of the machine, with the windings not under test and the core connected to the frame.

The test voltage is to be a voltage of sinusoidal wave form and a frequency of 25 Hz to 60 Hz. It is to be applied continuously for 60 seconds. The standard test voltage for all rotating machines is twice the rated voltage plus 1000 V, with a minimum of 1500 V, except for machine parts specified in the table below:

<i>Machine Part</i>	<i>Test Voltage (rms)</i>
Field windings of synchronous generators, synchronous motors and synchronous condensers: a) For all machines, except that in b) b) For motors started with field winding connected across resistance of more than ten times of the field winding resistance	a) Ten times the rated field voltage with a minimum of 1500 V and a maximum of 3500 V b) 1000 V + twice the maximum value of the voltage with a minimum of 1500 V
Phase-wound rotors of induction motors: a) For non-reversing motors or motors reversible from standstill only b) For motors reversible by reversing the primary supply while running	a) 1000 V + twice the open-circuit standstill secondary voltage b) 1000 V + four times the open-circuit standstill secondary voltage

Where a temperature rise test is to be performed, such as when performing type tests, the dielectric strength test is to be carried out immediately after this test.

Test voltage for other machines is to be in accordance with IEC Publication 60034-1, Table 16.

3.15.10 Running Balance Test

Motors are to be operated at no load and at rated speed while being supplied with a rated voltage and frequency; and in the case of a generator, driven by a suitable means and excited to give rated terminal voltage. The vibration of the machine and operation of the bearing lubrication system, where applicable, are to be checked and found satisfactory.

3.15.11 Bearings

Upon completion of tests in 4-8-3/3.15.10, machines having sleeve bearings are to be opened to establish that the shaft is properly seated in the bearings.

3.17 Certification

Each generator and motor of 100 kW (135 hp) and over intended for essential services (see 4-8-1/7.3.3), or for services indicated in 4-8-3/Table 7 is to be certified based on design review and type and routine tests performed in accordance with 4-8-3/Table 3 in the presence of a Surveyor.

At the option of the manufacturer, each machine design or type may be maintained on record as a design-assessed product in accordance with the provisions of 1-1-A3/5.1 of the *ABS Rules for Conditions of Classification (Part 1)*. In which case, each production unit of the type may be certified based only on routine test carried out to the satisfaction of a Surveyor at the manufacturer's facilities.

Further, at the option of the manufacturer, the quality assurance system of the manufacturing facilities may also be assessed in accordance with 1-1-A3/5.5 of the *ABS Rules for Conditions of Classification (Part 1)*. In which case, and along with approval of the design, the machine may be deemed type approved, and each production unit may be certified based on an audit by a Surveyor of the quality records maintained by the manufacturer. The machine may be posted on the ABS website, <http://www.eagle.org/typeapproval>.

5 Switchboards, Motor Controllers, etc.

5.1 Application

Main and emergency switchboards, power and lighting distribution boards, motor control centers and motor controllers, and battery charging and discharging boards are to be designed, constructed and tested in accordance with the provisions of this Subsection.

5.3 Construction, Assembly and Components

5.3.1 Enclosures

Enclosures and assemblies are to be constructed of steel or other suitable incombustible, moisture-resistant materials and reinforced as necessary to withstand the mechanical, electro-magnetic and thermal stresses which may be encountered under both normal and short-circuit fault conditions. No wood is to be used, except for hardwood for nonconducting hand rails. Insulating materials are to be flame retardant and moisture resistant. The supporting framework is to be of rigid construction.

Enclosures are to be of the closed type. The degree of the protection is to be in accordance with 4-8-3/Table 2.

All wearing parts are to be accessible for inspection and be readily renewable.

5.3.2 Bus Bars

5.3.2(a) General. Bus bars are to be copper; bus bars of other materials, such as aluminum bar covered by a properly bonded layer copper, will require special consideration. Bus bars are to be sized and arranged such that the temperature rise will not affect the normal operation of electrical devices mounted in the switchboard. The design maximum ambient temperature is to be in accordance with 4-8-3/1.17.

5.3.2(b) Bracing of Bus Bars. Bus bars and circuit breakers are to be mounted, braced and located so as to withstand thermal effects and magnetic forces resulting from the maximum prospective short-circuit current.

5.3.2(c) Bolted Connections. Bolted bus bar connections are to be suitably treated (e.g., silver plating) to avoid deterioration of electrical conductivity over time. Nuts are to be fitted with means to prevent loosening.

5.3.2(d) Cable Connections. Cable connections are to be made by the use of crimp lugs or equivalent. Soldered connections are not to be used for connecting or terminating any cable of 2.5 mm² or greater. Soldered connections, where used, are to have a solder contact length at least 1.5 times the diameter of the conductor.

5.3.2(e) *Clearance and Creepage.* Minimum clearances and creepage distances between live parts of different potential, i.e., between phases and between phase and the ground, are to be in accordance with the following table.

<i>Rated Insulation Voltage U_n (V)</i>	<i>Minimum Clearance (mm)</i>	<i>Minimum Creepage Distance (mm)</i>
$U_n \leq 250$	15	20
$251 < U_n \leq 690$	20	25
$690 < U_n \leq 1000$	25	35

5.3.2(f) *Alternative.* Alternatively, reduced creepage and clearance distances may be used provided:

- i) The equipment is not installed in ‘Machinery Spaces of Category A’ or in areas affected by a Local Fixed Pressure Water-spraying or Local Water-mist Fire Extinguishing System.
- ii) The minimum clearance distance shall not be less than 8 mm
- iii) The minimum creepage distance shall not be less than 16 mm.
- iv) The equipment complies with IEC 61439-1.
- v) In applying IEC 61439-1, the equipment is considered to be:
 - Of overvoltage Category III,
 - Installed in an environment of pollution degree 3,
 - Having insulating material of type IIIa, and
 - Installed in inhomogeneous field conditions
- vi) The temperature dependent criteria in IEC 61439-1 are derated to meet the ambient temperatures found on marine installations. Refer to 4-1-1/Table 8.
- vii) The equipment is subject to an impulse voltage test with test voltage values shown in the Table below. Where intermediate values of rated operational voltage are used, the next higher rated impulse withstand test voltage is to be used. The impulse voltage test reports are to be submitted to ABS for review.

<i>Rated Operational Voltage V</i>	<i>Rated Impulse Withstand Test Voltage kV</i>
50	0.8
100	1.5
150	2.5
300	4
600	6
1000	8

5.3.3 Circuit Breakers

5.3.3(a) *Compliance with a standard.* Circuit breakers are to be designed, constructed and tested to IEC Publication 60947-2 or other recognized standard. The certificates of tests are to be submitted upon request by ABS. Circuit breakers of the thermal type are to be calibrated for an ambient-air temperature, as provided in 4-8-3/1.17.

Note: Where thermal-type breakers are mounted within enclosures, the temperature within the enclosure may exceed the designated ambient-air temperature.

5.3.3(b) *Short-circuit capacity.* Circuit breakers are to have sufficient breaking and making capacities, as specified in 4-8-2/9.3.

5.3.3(c) *Removable mounting.* Circuit breakers are to be mounted or arranged in such a manner that the breakers may be removed from the front of the switchboard without first de-energizing the bus bars to which the breakers connect. Draw-out or plug-in type circuit breakers are acceptable for this purpose. Alternatively, an isolation switch may be fitted upstream (line or supply side) of the breaker. Consideration will be given to arrangements where portions may be isolated to allow circuit breaker removal, provided that this will not interrupt services for propulsion and safety of the vessel.

5.3.4 Fuses

Fuses are to be designed, constructed and tested in accordance with IEC Publication 60269 or other recognized standard. The certificates of tests are to be submitted upon request from ABS.

The requirements of 4-8-3/5.3.3(b) and 4-8-3/5.3.3(c) are to be complied with. Where disconnecting means are fitted, they are to be on the line or supply side. Where voltage to earth or between poles does not exceed 50 V DC or 50 V AC rms, fuses may be provided without switches. All fuses, except for instrument and control circuits are to be mounted on or accessible from the front of switchboard.

5.3.5 Disconnecting Device

The rating of the disconnecting devices is to be equal to or higher than the voltage and current ratings of connected load. The device is to have an indicator for its open or closed position.

5.3.6 Internal Wiring

5.3.6(a) *Wires.* Internal instrumentation and control wiring is to be of the stranded type and is to have heat-resisting and flame-retarding insulation. They are to be in compliance with a recognized standard.

5.3.6(b) *Protection.* In general, internal instrumentation and control wiring is to be protected by fuse or circuit breaker with the following exception:

- Generator voltage regulator circuits;
- Generator circuit breaker tripping control circuits; and
- Secondary circuit of current transformer.

These circuits, however, except that of the current transformer, may be fitted with short-circuit protection.

5.3.6(c) *Terminals.* Terminals or terminal rows for systems of different voltages are to be clearly separated from each other. The rated voltage is to be clearly indicated at least once for each group of terminals which have been separated from the terminals with other voltage ratings. Terminals with different voltage ratings, each not exceeding 50 V DC or 50 V AC may be grouped together. Each terminal is to have a nameplate indicating the circuit designation.

5.3.7 Circuit Identification

Identification plates for feeders and branch circuits are to be provided and are to indicate the circuit designation and the rating or settings of the fuse or circuit breaker of the circuit.

5.5 Main and Emergency Switchboards

In addition to the foregoing requirements, main and emergency switchboards are to comply with the following requirements.

5.5.1 Bus Bars

Generator bus bars are to be designed to meet the maximum generator rating based on ambient temperature of 45°C (113°F). Main bus bars are to be sized to the combined rated generator current that can flow through. Distribution bus bars and bus-bar connections are to be designed for at least 75% of the combined full-load rated currents of all loads they supply, or the combined current of the generators that can supply to that part of the bus, whichever is less. When a distribution bus bar supplies to one unit or one group of units in simultaneous operation, it is to be designed for full load.

5.5.2 Subdivision of Bus Bars

Refer to 4-8-2/3.13 for requirements for the division of main bus bars.

5.5.3 Hand Rails

Insulated handrail or insulated handles are to be provided for each front panel of the switchboard. Where access to the rear is required, insulated handrails or insulated handles are to be fitted to the rear of the switchboard also.

5.5.4 Instrumentation

Equipment and instrumentation are to be provided in accordance with 4-8-3/Table 5. They are to be suitable for starting, stopping, synchronizing and paralleling each generator set from the main switchboard. They may be mounted on the centralized control console if the main switchboard is located in the centralized control station.

5.7 Motor Controllers

In addition to the applicable requirements in 4-8-3/5.3, motor controllers are to comply with the following.

5.7.1 Overload and Undervoltage Protection

Overload protection and undervoltage protection where provided in the motor controllers are to be in accordance with 4-8-2/9.17.2 and 4-8-2/9.17.3.

5.7.2 Disconnecting Means

A circuit-disconnecting device is to be provided for each branch circuit of motor rated 0.5 kW or above so that the motor and the controller may be isolated from the power supply for maintenance purposes. However, for a pre-assembled or ski-mounted unit having two or more motors (e.g., fuel oil blender), a single disconnecting device in its feeder may be accepted in lieu of individual disconnecting devices for the motors, provided that the full load current of each motor is less than 6 A. The circuit-disconnecting device is to be operable externally. See also 4-8-4/9.3.

Where the controlgear is mounted on or adjacent to a main or auxiliary distribution switchboard, a disconnecting switch in the switchboard may be used for this purpose in accordance with 4-8-4/9.3.2. Otherwise, a disconnecting switch within the controlgear enclosure or a separate enclosed disconnecting switch is to be provided.

5.7.3 Resistor for Control Apparatus

Resistors are to be protected against corrosion either by rust-proofing or embedding in a protective material. Where fitted, the enclosure is to be well-ventilated and so arranged that other electrical equipment and wiring within will not be exposed to a temperature in excess of that for which they are designed.

5.7.4 Auto-starters

Alternating-current (AC) motor manual auto-starters with self-contained auto-transformers are to be provided with switches of the quick-make-and-break type, and the starter is to be arranged so that it will be impossible to throw to the running position without having first thrown to the starting position. Switches are to be preferably of the contactor or air-break-type.

5.9 Battery Systems and Uninterruptible Power Systems (UPS)

In addition to the applicable requirements in 4-8-3/5.3, equipment for essential, emergency, and transitional sources of power is to comply with the following. Such equipment would include:

- Battery charging and discharging units of 25 kW and over and the associated distribution boards.
- Uninterruptible power supply (UPS) units of 50 kVA and over and the associated distribution boards.

5.9.1 Definitions

Uninterruptible Power System (UPS) – A combination of converters, switches and energy storage means, for example batteries, constituting a power system for maintaining continuity of load power in case of input power failure.

Off-line UPS unit – A UPS unit where under normal operation the output load is powered from the bypass line (raw mains) and only transferred to the inverter if the bypass supply fails or goes outside preset limits. This transition will invariably result in a brief (typically 2 to 10 ms) break in the load supply.

Line interactive UPS unit – An off-line UPS unit where the bypass line switch to stored energy power when the input power goes outside the preset voltage and frequency limits.

On-line UPS unit – A UPS unit where under normal operation the output load is powered from the inverter, and will therefore continue to operate without break in the event of the supply input failing or going outside preset limits.

DC UPS unit – A UPS unit where the output is in DC (direct current).

5.9.2 Battery Charging Rate

Except when a different charging rate is necessary and is specified for a particular application, the charging facilities are to be such that the completely discharged battery can be recharged to 80% capacity in not more than 10 hours. See also 4-8-3/5.9.6(c).

5.9.3 Reversal of Charging Current

An acceptable means, such as reverse current protection, for preventing a failed component in the battery charger unit or uninterruptible power system (UPS) unit from discharging the battery, is to be fitted.

5.9.4 Design and Construction

5.9.4(a) Construction. Battery charger units and uninterruptible power system (UPS) units are to be constructed in accordance with the IEC 62040 Series, or an acceptable and relevant national or international standard.

5.9.4(b) Operation. The operation of the UPS is not to depend upon external services.

5.9.4(c) Type. The type of UPS unit employed, whether off-line, line interactive or on-line, is to be appropriate to the power supply requirements of the connected load equipment.

5.9.4(d) Continuity of Supply. An external bypass is to be provided to account for a failure within the uninterruptible power system (UPS). For battery charger units and DC UPS units, see 4-8-2/3.7.3.

5.9.4(e) Monitoring and Alarming. The battery charger unit or uninterruptible power system (UPS) unit is to be monitored and audible and visual alarm is to be given in a normally attended location for the following.

- Power supply failure (voltage and frequency) to the connected load
- Earth fault,
- Operation of battery protective device,
- When the battery is being discharged, and
- When the bypass is in operation for on-line UPS units. When changeover occurs, for battery charger units and DC UPS units required to comply with 4-8-2/3.7.3.

5.9.5 Location

5.9.5(a) Location. The UPS unit is to be suitably located for use in an emergency. The UPS unit is to be located as near as practical to the equipment being supplied, provided the arrangements comply with all other Rules, such as 4-8-4/5, 4-8-4/7 and 4-8-4/9 for location of electrical equipment.

5.9.5(b) Ventilation. UPS units utilizing valve regulated sealed batteries may be located in compartments with normal electrical equipment, provided the ventilation arrangements are in accordance with the requirements of 4-8-4/5.3 and 4-8-4/5.5. Since valve regulated sealed batteries are considered low-hydrogen-emission batteries, calculations are to be submitted in accordance with 4-8-4/5.5 to establish the gas emission performance of the valve regulated batteries compared to the standard lead acid batteries. Arrangements are to be provided to allow any possible gas emission to be led to the weather, unless the gas emission performance of the valve regulated batteries does not exceed that of standard lead acid batteries connected to a charging device of 0.2 kW.

5.9.5(c) Battery Installation. For battery installation arrangements, see 4-8-4/5.

5.9.6 Performance

5.9.6(a) Duration. The output power is to be maintained for the duration required for the connected equipment as stated in 4-8-2/5.5 for emergency services and 4-8-2/5.11 of transitional source of power, as applicable.

5.9.6(b) Battery Capacity. No additional circuits are to be connected to the battery charger unit or UPS unit without verification that the batteries have adequate capacity. The battery capacity is, at all times, to be capable of supplying the designated loads for the time specified in 4-8-3/5.9.6(a).

5.9.6(c) Recharging. On restoration of the input power, the rating of the charging facilities are to be sufficient to recharge the batteries while maintaining the output supply to the load equipment. See also 4-8-3/5.9.2.

5.9.7 Testing and Survey

5.9.7(a) Surveys. Equipment units are to be surveyed during manufacturing and testing in accordance with 4-8-3/5.11.

5.9.7(b) Testing. Appropriate testing is to be carried out to demonstrate that the battery charger units and uninterruptible power system (UPS) units are suitable for the intended environment. This is expected to include as a minimum the following tests:

- Functionality, including operation of alarms;
- Temperature rise;
- Ventilation rate;
- Battery capacity

5.9.7(c) Test upon power input failure. Where the supply is to be maintained without a break following a power input failure, this is to be verified after installation by practical test.

5.11 Testing and Certification

5.11.1 Certification

5.11.1(a) Essential and emergency services and services indicated in 4-8-3/Table 7. Switchboards and associated motor control centers and distribution board, motor controllers of 100 kW and over, battery charger units of 25 kW and over, uninterruptible power system (UPS) units of 50 KVA and over, and distribution boards [associated with the charging or discharging of the battery system or uninterruptible power system (UPS)], where required for essential services (see 4-8-1/7.3.3), and services indicated in 4-8-3/Table 7, transitional source of power (see 4-8-2/5.11) and for distribution of emergency source of power (see 4-8-2/5), are to be inspected by, tested in the presence of and certified by the Surveyor, preferably at the plant of the manufacturer. Small distribution boards required for similar services, but not forming a part of the switchboards or the battery charging and discharging boards referred to above, such as lighting distribution boards, may be treated as in 4-8-3/5.11.1(b). See also application of Type Approval Program in Appendix 1-1-A3 and 4-1-1/3.5 through 4-1-1/3.7.

5.11.1(b) Other services. Switchboards, distribution boards, motor controllers, etc., where required for services other than those in 4-8-3/5.11.1(a), may be tested by the manufacturers. Test certificates are to be submitted upon request by ABS.

5.11.2 Insulation Resistance Measurement

The insulation resistance between current-carrying parts and earth and between current-carrying parts of opposite polarity is to be measured at a DC voltage of not less than 500 V before and after the dielectric strength tests. The insulation resistance measurement after the dielectric strength tests is to be carried out before components which have been disconnected for the dielectric tests are reconnected, and the insulation resistance is not to be less than 1 megohm (MΩ).

5.11.3 Dielectric Strength Test

The dielectric strength of the insulation is to be tested for 60 seconds by an AC voltage applied, in accordance with the voltage values given in the following table, between:

- Each electric circuit, and
- All other electric circuits and metal parts earthed.

<i>Rated Voltage U_n (V)</i>	<i>AC Test Voltage rms (V)</i>
$U_n \leq 12$	250
$12 < U_n \leq 60$	500
$60 < U_n \leq 300$	2000
$300 < U_n \leq 690$	2500
$690 < U_n \leq 800$	3000
$800 < U_n \leq 1000$	3500
$1000 < U_n \leq 1500$ (DC only)	3500

The test voltage at the moment of application is not to exceed 50% of the values given in the above table. It is to be increased steadily within a few seconds to the required test voltage and maintained for 60 seconds. Test voltage is to have a sinusoidal waveform and a frequency between 45 Hz and 60 Hz. Certain devices such as potential transformers having inherently lower insulation strength are to be disconnected during the test.

Equipment and apparatus produced in large quantities for which the standard test voltage is 2500 V or less may be tested for one second with a test voltage 20% higher than the 60-second test voltage.

5.11.4 Operational Tests

Operational tests are to be carried out including but not limited to the testing of protective devices (overcurrent, undervoltage, and preferential trippings, etc.), electrical interlocks, synchronization of generators, earth detection, alarms and measurement of bus bar temperature rise [see 4-8-3/5.3.2 (a)].

With the UPS unit initially switched off and with no external power supply to the UPS itself, it is to be demonstrated that the UPS can be switched on to supply the load.

7 Transformers

7.1 Enclosures

Transformers are to be provided with enclosures with a minimum degree of protection, as specified in 4-8-3/Table 2.

7.3 Transformers for Essential Services

Transformers for essential services and for emergency source of power are to be constructed in accordance with the following requirements. Other transformers, including auto-transformers for starting motors and isolation transformers, may be constructed in accordance with good commercial practice.

7.3.1 Rating

Transformers are to be continuously rated based on the maximum expected ambient temperature to which they are subjected, but not less than 45°C (113°F). Temperature rises in accordance with alternative transformer construction standards may also be considered. Also, refer to 4-8-3/1.17 for electrical equipment installed spaces considered to have lower ambient temperatures and in environmentally controlled spaces.

7.3.2 Temperature Rise

The maximum temperature rise of the transformer insulated windings, based on an ambient temperature of 45°C (113°F), is not to exceed that in the following table:

<i>Insulation Class</i>	<i>Average Winding-Temperature Rise Limits at Rated Current, °C (°F)</i>
A (105)	55 (99)
E (120)	70 (126)
B (130)	75 (135)
F (155)	95 (171)
H (180)	120 (216)
200	130 (234)
220	145 (261)

7.3.3 Cooling Medium

Transformers are to be of the dry and air cooled type. The use of liquid immersed type transformers will be subject to special consideration. Where forced circulation of cooling medium is employed, high temperature condition is to be alarmed.

7.3.4 Prevention of the Accumulation of Moisture

Transformers of 10 kVA/phase and over are to be provided with effective means to prevent accumulation of moisture and condensation within the transformer enclosure where the transformer is disconnected from the switchboard during standby (cold standby). Where it is arranged that the transformer is retained in an energized condition throughout a period of standby (hot standby), the exciting current to the primary winding may be considered as a means to meet the above purpose. In case of hot standby, a warning plate is to be posted at or near the disconnecting device for the primary side feeder to the transformer.

7.3.5 Testing

Single-phase transformers rated 1 kVA and above and three-phase transformers rated 5 kVA and above, intended for essential or emergency services, are to be tested by the manufacturer whose certificate of tests will be acceptable and are to be submitted upon request by ABS. The tests are to include at least the following:

- Measurement of winding resistance, voltage ratio, impedance voltage, short-circuit impedance, insulation resistance, load loss, no load loss and excitation current, phase relation and polarity.
- Dielectric strength.
- Temperature rise (required for transformer of each size and type).

7.3.6 Nameplate

Nameplates of corrosion-resistant material are to be provided in an accessible position of the transformer and are to indicate at least the following information:

- The manufacturer's name
- The manufacturer's serial number (or identification mark)
- The year of manufacture
- The number of phases
- The rated power
- The rated frequency
- The rated voltage in primary and secondary sides
- The rated current in primary and secondary sides
- The class of insulation or permissible temperature rise
- The ambient temperature

8 Semiconductor Converters for Adjustable Speed Motor Drives

8.1 Application

All semiconductor converters that are used to control motor drives having a rated power of 100 kW (135 hp) and over intended for essential services (see definition in 4-8-1/7.3.3) or for services indicated in 4-8-3/Table 7 are to be designed, constructed and tested in accordance with the requirements of 4-8-3/8.

Manufacturer's tests for semiconductor converters that are used to control motor drives having a rated power less than 100 kW (135 hp) for essential services (see definition in 4-8-1/7.3.3) or for services indicated in 4-8-3/Table 7 are to include at least the tests described in 4-8-3/8.7. All other semiconductor converters used to control motor drives are to be designed, constructed and tested in accordance with established industrial practices and manufacturer's specifications.

The required tests may be carried out at the manufacturer facility whose certificates of tests will be acceptable and are to be submitted upon request to ABS. All semiconductor converters will only be accepted subject to a satisfactory performance test conducted to the satisfaction of the attending Surveyor after installation.

8.3 Standards of Compliance

The design of semiconductor converters for adjustable speed motor drives, unless otherwise contradicted by ABS Rules, shall be in compliance with the requirements of IEC Publication 61800-5-1:2007 (titled 'Adjustable speed electrical power drive systems : Safety Requirements – Electrical, thermal and energy') and 60146-1-1:2009 (titled 'Semiconductor converters – General requirements and line commutated converters – Specification of basic requirements). For convenience, the following requirements are listed.

8.5 Design, Construction and Assembly Requirements

8.5.1 Rating

Semiconductor converters are to be rated for continuous load conditions and if required by the application, are to have specified overload capabilities.

The operation of the semiconductor converter equipment, including any associated transformers, reactors, capacitors and filter circuits, shall not cause harmonic distortion and voltage and frequency variations in excess of the values mentioned in 4-8-2/7.21 and 4-8-3/1.9, respectively.

The semiconductor converter circuits shall be able to withstand voltage and current transients that the system may be subject to for certain applications.

The semiconductor converters are to be suitable for environmental conditions found in marine installations such as those mentioned in 4-1-1/Table 7 and 4-1-1/Table 8.

8.5.2 Enclosures

Enclosures and assemblies are to be constructed of steel or other suitable incombustible, moisture-resistant materials and reinforced as necessary to withstand the mechanical, electro-magnetic and thermal stresses which may be encountered under both normal and fault conditions.

Enclosures are to be of the closed type. The degree of protection of the enclosure is to be in accordance with 4-8-3/Table 2. For HV converters, the enclosure is to satisfy the requirements in 4-8-5/Table 1.

All wearing parts are to be accessible for inspection and be readily replaceable.

8.5.3 Nameplate Data

A nameplate made of corrosion resistant material is to be provided on the semiconductor assembly and is to indicate at least the following:

- i) Manufacturer's name and identification reference/equipment serial number
- ii) Number of input and output phases
- iii) Rated input voltage and current
- iv) Rated output voltage and current

- v) Rated input and output frequency, if any
- vi) Range of output frequency
- vii) Maximum permissible prospective symmetrical rms short-circuit current of the power source
- viii) Cooling methods
- ix) Degree of protection

8.5.4 Warning Labels

Appropriate warning labels informing the user of the dangers with working with the different parts of the converter assembly is to be placed at all appropriate places of the assembly.

8.5.5 Hand Rails

Insulated handrails or insulated handles are to be provided for each front panel of the assembly. Where access to the rear is also required, insulated handrails or insulated handles are to be fitted to the rear of the assembly as well.

8.5.6 Accessibility

All components of the semiconductor converter assembly are to be mounted in such a manner that they can be removed from the assembly for repair or replacement without having to dismantle the complete unit.

8.5.7 Capacitor Discharge

Capacitors within a semiconductor converter assembly shall be discharged to a voltage less than 60 V, or to a residual charge less than 50 μC , within 5 seconds after the removal of power. If this requirement cannot be met, appropriate warning labels shall be placed on the assembly.

8.5.8 Cooling Arrangements

Design of cooling systems is to be based on an ambient air temperature of 45°C (113°F) indicated in 4-1-1/7.11 and 4-1-1/Table 8.

Semiconductor converter assemblies are to be installed away from sources of radiant energy in locations where the circulation of air is not restricted to and from the assembly and where the temperature of the inlet air to air-cooled converters will not exceed that for which the converter has been designed.

Where arrangements for forced cooling have been provided, the equipment is, unless otherwise specifically required, to be designed such that power cannot be applied to, or retained on, the semiconductor circuits, unless effective cooling is maintained. Other effective means of protection against equipment over-temperature such as reduction in the driven load may also be acceptable.

Semiconductor assemblies with forced cooling are to be provided with a means of monitoring the temperature of the cooling medium. Over-temperature of the cooling medium is to be alarmed locally and at a continuously manned location and the equipment shutdown when temperature exceeds the manufacturer specified value.

Semiconductor assemblies with liquid cooling are to be provided with a means to detect leakage. In case of leakage, an audible and visible alarm is to be initiated locally and remotely at a continuously manned location. Means to contain any leakage are to be provided so that the liquid does not cause a failure of the semiconductor assembly or any other electrical equipment located near the converter. Where the cooling liquid is required to be non-conducting, the conductivity of the cooling liquid is to be monitored and an alarm given both locally and remotely in a continuously manned location if the conductivity exceeds the manufacturer specified value.

In case of failure of the cooling system, an alarm is to be given both locally and remotely at a continuously manned location and the output current is to be reduced automatically.

Cooling liquids which are in contact with live unearthed parts of the assembly, are to be non-conductive and non-flammable.

8.5.9 Emergency Stop

When required, semiconductor converter assemblies shall be provided with an emergency stop function. The emergency stop circuit is to be hard-wired and independent of any control system signal.

8.5.10 Electrical Protection

8.5.10(a) Overvoltage Protection. Means are to be provided to prevent excessive overvoltage in a supply system to which semiconductor converters are connected and to prevent the application of voltages in excess of the rating of semiconductor devices.

8.5.10(b) Overcurrent Protection. Arrangements are to be made so that the permissible current of semiconductor converters or semiconductor devices associated with the semiconductor converter cannot be exceeded during operation.

8.5.10(c) Short Circuit Protection. Semiconductor converters and the associated semiconductor devices are to be protected against short circuit.

8.5.10(d) Filter Circuits. Filter circuits are to be protected against overvoltage, overcurrent and short circuit.

8.5.10(e) Alarms. Visual and audible alarms are to be provided at the control station in the event of operation of the protection system.

8.5.11 Clearance and Creepage Distances

Clearance and creepage distances used in standard production (COTS) semiconductor converter assemblies are to be in accordance with IEC 61800-5-1 and suitable for overvoltage category III, pollution degree 3 and insulating material group IIIa. The relevant values are reproduced in the Table below for convenience.

<i>System Voltage (V)</i>	<i>Minimum Clearance Distance (mm)</i>
≤50	0.8
100	0.8
150	1.5
300	3.0
600	5.5
1000	8.0
3600	25
7200	60
12000	90
15000	120

Note: Interpolation is permitted.

<i>Working Voltage (rms) (V)</i>	<i>Minimum Creepage Distance (mm)</i>
50	1.9
100	2.2
125	2.4
160	2.5
200	3.2
250	4.0
320	5.0
400	6.3
500	8.0
630	10.0
800	12.5
1000	16

<i>Working Voltage (rms) (V)</i>	<i>Minimum Creepage Distance (mm)</i>
1250	20
1600	25
2000	32
2500	40
3200	50
4000	63
5000	80
6300	100
8000	125
10000	160

Note: Interpolation is permitted.

8.5.12 Protection and Monitoring Requirements

Semiconductor assemblies, as a minimum, shall have alarm functions for the following parameters:

- i)* Overcurrent
- ii)* Overload
- iii)* Overvoltage
- iv)* Ground fault
- v)* Loss of cooling
- vi)* Increase in resistivity of cooling medium (for liquid cooled converters)
- vii)* Over-temperature
- viii)* Loss of communication to process control
- ix)* Loss of motor speed feedback

If harmonic filters are used in conjunction with semiconductor converter assemblies, refer to 4-8-2/9.23 for additional protection requirements.

For vessels with electric propulsion, refer to 4-9-6/Table 4A.

8.5.13 Load-Sharing

When semiconductor converters have multiple parallel/series circuits, load sharing between the multiple circuits is to be distributed uniformly, as far as practicable.

8.5.14 EMC Emission Requirements

If requested by the customer, EM immunity and EM emissions testing of the semiconductor assembly shall be done as an optional test in accordance with IEC 61800-3 (titled 'Adjustable speed electrical power drive systems – Part 3: EMC requirements and specific test methods').

Note: Radiated and conducted emissions/immunity does not depend on the equipment alone but also on the interaction between the semiconductor converter assembly and the rest of the power system. There shall be communication between the manufacturer and the customer as to what installation guidelines may need to be followed to satisfy the different EM emission/immunity requirements, such as cable routing, types of interconnect cables used, cable shielding, etc.

8.5.15 Harmonic Filter Requirements

If harmonic filter circuits are used in association with semiconductor converter assemblies to reduce the harmonics and transients in the system, they are to comply with the requirements in 4-8-2/9.23.

8.5.16 Performance

The converter control system shall be able to control the motor by speed ramp, torque or power, as per customer specification.

Upon loss of the reference signal, the converter shall either decelerate the driven motor to minimum speed/torque/power or down to standstill as per customer specification for the required application.

When, during normal operation, the motor is decelerated to standstill, it shall be possible to de-energize the motor by blocking the control signals to the power semiconductors, while leaving the converter input circuit energized.

When automatic restart is specified, the converter shall be capable of catching an already spinning motor.

8.7 Inspection and Testing

Semiconductor assemblies for motor drives shall undergo Type tests, Routine tests and Optional tests, if any specifically required by the Owner, at manufacturer's production facility as per the Table below. The Type tests, Routine tests and Optional tests shall be conducted in the presence of and witnessed by an ABS Surveyor. Type tests shall be carried out one prototype of a converter or the first of a batch of identical converters. Routine tests shall be carried on each assembly. A summary of the required type tests and routine tests are given in the Table below:

No.	Tests (see 4-8-3/8.7)	Type Test	Routine Test	ABS MVR Reference	IEC Test Reference
1	Visual inspection	x	x	4-8-3/8.7.1	61800-5-1/5.2.1
2	Insulation test (AC or DC voltage test)	x	x	4-8-3/8.7.2	61800-5-1/5.2.3.2
3	Insulation resistance test	x	x	4-8-3/8.7.4	60146-1-1/7.2.3.1
4	Impulse voltage test	x		4-8-3/8.7.3	61800-5-1/5.2.3.1
5	Cooling system test	x	x	4-8-3/8.7.5	61800-5-1/5.2.4.5
6	Breakdown of components test	x		4-8-3/8.7.6	61800-5-1/5.2.3.6.4
7	Light load and functional test	x	x	4-8-3/8.7.7	60146-1-1/7.3.1
8	Rated current test	x		4-8-3/8.7.8	60146-1-1/7.3.2
9	Temperature rise test	x		4-8-3/8.7.9	61800-5-1/5.2.3.8
10	Capacitor discharge test	x		4-8-3/8.7.10	61800-5-1/5.2.3.7

8.7.1 Visual Inspection

Semiconductor assemblies are subject to visual inspection for the following aspects:

- i) Verify enclosure integrity, alignment of different cabinets in the assembly as per system drawings.
- ii) Verify if nameplate is present as per 4-8-3/8.5.3.
- iii) Check if adequate and visible warning and safety labels are present.
- iv) General hardware and electrical point-to-point wire check.
- v) Verify correct routing and connections of fiber optic cables and ethernet cables.
- vi) Verify correct connection of grounding wires on the assembly.
- vii) Point-to-point inspection of cooling system, if applicable. For drive assemblies with liquid cooling, verification of proper installation of piping and hoses, correct orientation of flow restrictors and related coolant liquid monitoring instrumentation.
- viii) Door interlocks, if any

8.7.2 Insulation Test (AC or DC Voltage Test)

Semiconductor assemblies shall be subject to insulation tests to ensure adequate dielectric strength of insulation of its components and to verify that clearance distances have not been compromised during manufacturing operations. The insulation test is to be performed with the appropriate AC or DC voltage (equal to the peak value of the specified AC rms voltage) mentioned in Table 21/ Table 22/ Table 23 of IEC 61800-5-1(2007). The AC test voltage is to be voltage of sinusoidal wave form and a frequency of 50 Hz/60 Hz. The duration of the test is to be at least 5 sec for the Type Test and 1 sec for the Routine Test. All main power, control power and logic circuits have to be subject to the insulation test.

8.7.3 Impulse Voltage Test

Semiconductor assemblies shall be subject to an Impulse voltage test to simulate the impact of impulse transient over voltages generated in the mains supply or those caused by switching of equipment. The impulse voltage test is to be done as per 5.2.3.1 of IEC 61800-5-1(2007). For purposes of selection of test voltages, the semiconductor assembly shall be treated as belonging to overvoltage category III.

Impulse voltage tests shall be done as a routine test on assemblies that do not satisfy the clearance and creepage distance requirements of 4-8-3/8.5.11.

8.7.4 Insulation Resistance Test

One minute after the insulation test, insulation resistance shall be measured by applying a direct voltage of at least 500 V.

8.7.5 Cooling System Test

Semiconductor assemblies shall be subject to cooling system tests that test for failure of the cooling system and the associated response of the semiconductor assembly to these cooling system failures as per 5.2.4.5 of IEC 61800-5-1 (2007).

In addition, for liquid cooled semiconductor assemblies, the cooling piping system shall be subject to a coolant leak pressure test. The cooling system piping shall be hydrostatically tested to 1.5 times the design pressure for a period of 30 minutes. The pressure relief mechanism shall also be checked for proper calibration and operation. The cooling system shall be verified as having no leakage by monitoring the pressure and by visual inspection.

The instrumentation critical to the operation of the cooling system such as valve positions, programming of level switch sensors, flow sensors, pressure sensors, temperature sensors, pressure relief valve operation, coolant conductivity sensor, etc., shall be checked to ensure correct calibration and functionality.

8.7.6 Breakdown of Components Test

Components which have been identified by circuit analysis could result in a thermal or electric shock hazard are to be subject to a breakdown test as per 5.2.3.6.4 of IEC 61800-5-1.

8.7.7 Light Load and Functional Test

Semiconductor assemblies shall be subject to a light load and functional test to ensure that all parts of the electrical circuit and the cooling system work properly together and that the assembly meets the required proof of performance as per customer requirements. The main things to be checked include, but are not limited to:

- i) Verify that the control equipment, auxiliaries, protection equipment and main circuit are operating properly together.
- ii) Check power supplies to different power and control circuits of the assembly and associated communication control interfaces.
- iii) Check pre-charge circuit settings.
- iv) Verify the various software parameters.

- v) Check for voltage/current sharing in the semiconductor devices used in the arms of the converter.
- vi) Testing of the converter for scenarios like, but not limited to, emergency trip of the assembly, input fault protection, loss of cooling, local and remote control operation, etc.
- vii) Testing of the converter for any specific customer defined scenario like output power ramp-down on loss of input power, ability of the converter to catch a spinning motor after recovering from a trip or from automatic restart, etc.

8.7.8 Rated Current Test

The test is carried out to verify that the equipment will operate satisfactorily at rated current. The DC terminals shall be short-circuited directly or with a reactor and an alternating voltage of sufficient value, to cause at least the rated continuous direct current to flow, shall be connected to the AC terminals of the converter and operation of the assembly shall be checked.

8.7.9 Temperature Rise Test

The test is carried out to verify that parts and accessible surfaces of the semiconductor assembly do not exceed temperature limits specified below and the manufacturer's temperature limits of safety-relevant parts. The temperature rise test is to be conducted at worst-case conditions of rated power and rated output current.

<i>Materials and Components</i>	<i>Thermometer Method (°C)</i>	<i>Resistance Method (°C)</i>
Rubber/Thermoplastic-insulated conductors	55	-
User terminals	Note 1	-
Copper bus bars and connecting straps	120	-
Winding Insulation		
Class A	95	105
Class E	100	115
Class B	105	125
Class F	115	135
Class H	135	155
Class N	175	195
Phenolic composition	145	-
Bare resistor material	395	-
Capacitor	Note 2	-
Power switching semiconductors	Note 2	-
Printed wiring boards (PWB's)	Note 2	-
Liquid cooling medium	Note 2	-

Notes:

- 1 Maximum terminal temperature shall not exceed 15°C more than the insulation temperature rating of the conductor or cable specified by the manufacturer.
- 2 Maximum temperature shall be as specified by the manufacturer.

8.7.10 Capacitor Discharge Test

Verification of the capacitor discharge time as required in 4-8-3/8.7.7 is required to be done by a test and/or by calculation.

8.9 Integration Requirements

8.9.1 Integration

In cases where the semiconductor converters are integrated into larger assemblies that have other components (i.e., transformers, reactors, motors, etc.), the individual tests of the other components shall be done in accordance with relevant portions of the ABS Rules.

Installation requirements such as earthing of equipment, selection of cable and acceptable cable lengths, etc., should be as per manufacturer installation guidelines.

8.9.2 Reactors and Transformers for Semiconductor Converters

8.9.2(a) Voltage Regulation. Means to regulate transformer output voltage are to be provided to take care of increase in converter forward resistance and, in addition, to obtain the necessary performance characteristics of the converter unit in which the transformer is used.

8.9.2(b) High Temperature Alarm. Interphase reactors and transformers used with the semiconductor converters for main and auxiliary propulsion systems are to be provided with a high temperature alarm at the switchboard or the propulsion control station. The setting value of the alarm is to be determined by their specific insulation class and is not to exceed the temperature corresponding to the limit listed in 4-8-3/7.3.2.

8.9.3 Critical Speeds

The semiconductor converter supplier, the driven equipment supplier and the Owner should come to an agreement on the calculations of the resulting critical lateral speeds of the whole mechanical string with special attention being paid to the following:

- i) Take into account the influence of the stiffness of the bearing arrangement and the foundation.
- ii) Avoid any continuous running with insufficient damping close to lateral critical speeds ($\pm 20\%$).

9 Cables

9.1 Standard of Compliance

Electric cables constructed of stranded copper conductors, thermoplastic, elastomeric or other insulation, moisture-resistant jackets, and, where applicable, armoring and outer-sheathing are to be in accordance with IEC Publication 60092-350, 60092-352, 60092-353, 60092-354, 60092-360, 60092-370, 60092-376, IEEE Std-45 or other marine standards of an equivalent or higher safety level, acceptable to ABS. Network cables are to comply with a recognized industry standard. Cables such as flexible cable, fiber-optic cable, etc., used for special purposes may be accepted provided they are manufactured and tested in accordance with recognized standards accepted by ABS.

Note: See clause 3.16 and clause 4.6 of IEC 60092-350 concerning the provision of an extruded impervious inner sheath that will prevent the migration of gas through the cable.

9.3 Current Carrying Capacity

9.3.1 Current Carrying Capacity

Maximum current carrying capacities of cables conforming to IEC Publications 60092-353 are to be in accordance with the values given in 4-8-3/Table 6. These values are applicable for cables installed double-banked on cable trays, in cable conduits or cable pipes. The values, however, are to be reduced for installations where there is an absence of free air circulation around the cables. See 4-8-2/7.7.1 and Note 4 of 4-8-3/Table 6.

9.4 Minimum Cable Conductor Size

Conductors are not to be less than the following in cross sectional size:

- 1.0 mm² (1,973.5 circ. mils) for power and lighting,
- 0.5 mm² (986.8 circ. mils) for control cables,
- 0.5 mm² (986.8 circ. mils) for essential or emergency signaling and communications cables, except for those assembled by the equipment manufacturer, and
- 0.35 mm² (690.8 circ. mils) for telephone cables for nonessential communication services, except for those assembled by the equipment manufacturer.

9.5 Flame Retardant Standard

Electrical cables are to be flame retardant and complying with any of the following:

- i) Depending on the intended installation, cables constructed to IEC Publication 60092 standards are to comply with the flammability criteria of IEC Publication 60332-3-22 or 60332-3-21, Category A or A F/R, or
- ii) Cables constructed to IEEE Std 45 are to comply with the flammability criteria contained therein.
- iii) Cables constructed to other standards, where accepted by ABS, are to comply with the flammability criteria of IEC Publication 60332-3-22 or 60332-3-21, category A or A F/R (depending on the intended installation) or other acceptable standards.

Flame-retardant marine cables which have not passed the bunched cable flammability criteria as per IEC Publication 60332-3-22 or 60332-3-21 may be considered, provided that the cable is treated with approved flame-retardant material or the installation is provided with approved fire stop arrangements.

Consideration will be also given to the special types of cables, such as radio frequency cable, which do not comply with the above requirements.

Where the network cables are installed in bunched configuration and they do not comply with IEEE Std 45 or IEC Publication 60332-3-22 or 60332-3-21 Category A or A F/R, the installation is to be provided with approved fire stop arrangements.

9.7 Fire Resistant Standard

Where electrical cables are required to be fire resistant, they are to comply with the requirements of IEC Standard 60331-1 for cables greater than 20 mm overall in diameter, otherwise they are to comply with the IEC Standard 60331-2 for cable diameters 20 mm or less. For special cables, requirements in the following standards may be used:

- IEC Standard 60331-23: Procedures and requirements – Electric data cables
- IEC Standard 60331-25: Procedures and requirements – Optical fiber cables

Cables complying with alternative national standards suitable for use in a marine environment may be considered. Fire resistant type cables are to be easily distinguishable. See also 4-8-4/1.9 and 4-8-4/21.17.

9.9 Insulation Temperature Rating

All electrical cables for power and lighting circuits are to have insulation suitable for a conductor temperature of not less than 60°C (140°F), See 4-8-3/Table 6, Note 1.

9.11 Armor for Single Core Cables

The armor is to be non-magnetic for single-conductor alternating-current cables. See also 4-8-4/21.7 for installation arrangements of single conductor cables.

9.13 Fiber Optic Cables

Fiber optic cables are to comply with a standard acceptable to ABS. The flame-retardant standard for electrical cables is also applicable to fiber optic cables.

9.15 Mineral-insulated Metal-sheathed Cables

Mineral-insulated cable provided with approved fittings for terminating and connecting to boxes, outlets and other equipment may be used for any service up to 600 V, and may be used for feeders and branch circuits in both exposed and concealed work in dry or wet locations. The moisture-resisting jacket (sheath) of mineral-insulated metal-sheathed cable exposed to corrosive conditions is to be made of or protected by materials suitable for those conditions.

9.17 Test and Certification

Electrical cables are to be tested by the manufacturers in accordance with the standards of compliance. Records of test are to be maintained and are to be submitted upon request by ABS. Preferably, electrical cables are to be type approved; see 4-1-1/3.3 through 4-1-1/3.7. For propulsion cables, see 4-8-5/5.17.11.

9.19 Cable Splices

Cable splice is to be made of fire resistant replacement insulation equivalent in electrical and thermal properties to the original insulation. The replacement jacket is to be at least equivalent to the original impervious sheath and is to assure a watertight splice. Splices are to be made using the splice kit, which is to contain the following:

- Connector of correct size and number
- Replacement insulation
- Replacement jacket
- Instructions for use

All cable splices are to be type-tested and approved for fire resistance, watertightness, dielectric strength, etc., or type approved (see 1-1-A3/1 of the *ABS Rules for Conditions of Classification (Part 1)*) before use.

9.21 Cable Junction Boxes

Junction box is to be constructed of material durable, flame-retardant, moisture-resistant as described in 4-8-3/1.7. Live parts within the box are to be provided with suitable clearances and creepage distances, or with shielding by flame retarding insulation material. Junction boxes having compartments for different voltage levels are to have each compartment appropriately identified as to its rated voltage. Cables within the junction boxes are to be well supported so as not to put stress on the cable contacts. In general, junction boxes are to comply with a recognized standard or type approved (see 1-1-A3/1 of the *ABS Rules for Conditions of Classification (Part 1)*).

11 Non-sparking Fans

11.1 Design

11.1.1 Air Gap

The air gap between the impeller and the casing is to be not less than 10% of the shaft diameter in way of the impeller bearing but, in any case, not to be less than 2 mm (0.08 in.). It need not be more than 13 mm (0.5 in.).

11.1.2 Protection Screen

Protection screens of not more than 13 mm (0.5 in.) square mesh are to be fitted in the inlet and outlet of ventilation openings on the open deck to prevent the entrance of object into the fan casing.

11.3 Materials

11.3.1 Impeller and its Housing

Except as indicated in 4-8-3/11.3.3, the impeller and the housing in way of the impeller are to be made of alloys which are recognized as being spark proof by means of appropriate test procedures.

11.3.2 Electrostatic Charges

Electrostatic charges both in the rotating body and the casing are to be prevented by the use of anti-static materials. Furthermore, the installation of the ventilation fan is to ensure its bonding to the hull.

11.3.3 Acceptable Combination of Materials

Materials tests referred to in 4-8-3/11.3.1 above are not required for fans having the following combinations:

- i) Impellers and/or housings of nonmetallic material, due regard being paid to the elimination of static electricity;
- ii) Impellers and housings of non-ferrous materials;
- iii) Impellers of aluminum alloys or magnesium alloys and a ferrous (including austenitic stainless steel) housing on which a ring of suitable thickness of non-ferrous materials is fitted in way of the impeller;
- iv) Any combination of ferrous (including austenitic stainless steel) impellers and housings with not less than 13 mm (0.5 in.) tip design clearance.

11.3.4 Unacceptable Combination of Materials

The following impellers and housings are considered as spark-producing and are not permitted:

- i) Impellers of an aluminum alloy or magnesium alloy and a ferrous housing, regardless of tip clearance;
- ii) Housing made of an aluminum alloy or a magnesium alloy and a ferrous impeller, regardless of tip clearance;
- iii) Any combination of ferrous impellers and housings with less than 13 mm (0.5 in.) design tip clearance.

11.5 Type Test

Type tests on the finished product are to be carried out in accordance with an acceptable national or international standard. Such type test reports are to be made available when requested by the Surveyor.

13 Certified Safe Equipment

13.1 General

Certified safe equipment is equipment intended for installation in hazardous areas where flammable or explosive gases, vapors, or dust are normally or likely to be present. The equipment is to be type-tested and certified by a competent, independent testing laboratory for complying with IEC Publication 60079 series or other recognized standard, and rated according to its enclosure and the types of flammable atmosphere in which it is safe to install. If desired, the manufacturer may have such equipment type approved (see 1-1-A3/1 of the *ABS Rules for Conditions of Classification (Part 1)*).

13.3 Acceptable Types of Certified Safe Equipment

The following type of electrical equipment, expressed in IEC Publication 60079 series nomenclature, will be acceptable for installation in hazardous areas identified in the Rules. Other types, as well as equipment complying with another recognized standard, will also be considered.

13.3.1 Intrinsically Safe Equipment – ‘Ex ia’ and ‘Ex ib’

An intrinsically safe equipment is one which is supplied by a low energy circuit which when sparking, produced normally by breaking or making the circuit or produced accidentally (i.e., by short circuit or earth-fault), is incapable under prescribed test conditions of causing ignition of a prescribed gas or vapor.

13.3.2 Flameproof (Explosion-proof) Equipment – ‘Ex d’

Flameproof equipment is one which possesses an enclosure capable of withstanding, without damage, an explosion of a prescribed flammable gas or vapor within the enclosure and prevent the transmission of flame or sparks which would ignite the external prescribed flammable gas or vapor for which it is designed, and which normally operates at an external temperature that will not ignite the external prescribed flammable gas or vapor. A flameproof enclosure may not necessarily or ordinarily be weatherproof or dustproof.

13.3.3 Increased Safety Equipment – ‘Ex e’

Increased safety equipment is designed with a method of protection in which measures additional to those adopted on ordinary industrial practice are applied, so as to give increased security against the possibility of excessive temperatures and the occurrence of arcs or sparks in electrical apparatus which does not produce arcs or sparks in normal service.

13.3.4 Pressurized or Purged Equipment – ‘Ex p’

Pressured equipment is designed with an enclosure in which the entry of flammable gases or vapors is prevented by maintaining the air (or other non-flammable gas) within the enclosure at a specified pressure above that of the external atmosphere. Purged equipment is designed with an enclosure in which a sufficient flow of fresh air or inert gas is maintained through the enclosure to prevent the entry of any flammable gas or vapor which may be present in the ambient atmosphere.

13.5 Flammable Gas Groups and Temperature Classes

Certified safe equipment is to be rated for the flammable atmosphere in which it is safe to install. Each flammable atmosphere is to be identified with respect to the flammable gas, vapor or dust and its self-ignition temperature; the latter is used to limit the maximum permissible external surface temperature of the equipment. The following tables show the typical flammable gas groups and the temperature classes as in IEC Publication 60079-20:

<i>Gas Group</i>	<i>Representative Gas</i>
I	Methane (see note below)
IIA	Propane
IIB	Ethylene
IIC	Hydrogen

<i>Temperature Class</i>	<i>Maximum Surface Temperature, °C</i>
T1	≤ 450
T2	≤ 300
T3	≤ 200
T4	≤ 135
T5	≤ 100
T6	≤ 85

Note: While methane of firedamp and mining applications, such as methane generated from coal, is classified as Group I, industrial methane, such as natural gas, is to be classified as Group IIA with temperature Class T1, if it does not contain more than 15% (V/V) of hydrogen. A mixture of industrial methane with other compounds from Group IIA, in any proportion, is also classified as Group IIA with temperature Class T1.

15 Computer-based Systems

Equipment covered by Part 4, Chapter 8 which relies on computer-based systems/components for control, monitoring or safety functions, is to comply with Section 4-9-3.

TABLE 1A
Degree of Protection of Electrical Equipment (First IP Numeral)

<i>First IP numeral</i>	<i>Short description</i>	<i>Definition</i>
0	Non-protected	No special protection
1	Protected against solid objects greater than 50 mm (2 in.)	A large surface of the body, such as a hand (but no protection against deliberate access). Solid object exceeding 50 mm (2 in.) in diameter.
2	Protected against solid objects greater than 12 mm (0.5 in.)	Fingers or similar objects not exceeding 80 mm (3.15 in.) in length. Solid objects exceeding 12 mm (0.5 in.) in diameter.
3	Protected against solid objects greater than 2.5 mm (0.1 in.)	Tools, wires, etc. of diameter or thickness greater than 2.5 mm (0.1 in.). Solid objects exceeding 2.5 mm (0.1 in.) in diameter
4	Protected against solid objects greater than 1 mm (0.04 in.)	Wires or strips of thickness greater than 1 mm (0.04 in.). Solid objects exceeding 1 mm (0.04 in.) in diameter.
5	Dust protected	Ingress of dust is not totally prevented, but dust does not enter in sufficient quantity to interfere with satisfactory operation of the equipment
6	Dust-tight	No ingress of dust

TABLE 1B
Degree of Protection of Electrical Equipment (Second IP Numeral)

<i>Second IP numeral</i>	<i>Short description</i>	<i>Definition</i>
0	Non-protected	No special protection.
1	Protected against dripping water	Dripping water (vertically falling drops) is to have no harmful effect.
2	Protected against dripping water when tilted up to 15°.	Vertically dripping water is to have no harmful effect when the enclosure is tilted at any angle up to 15° from its normal position.
3	Protected against spraying water	Water falling as spray at an angle up to 60° from the vertical is to have no harmful effect.
4	Protected against splashing water	Water splashed against the enclosure from any direction is to have no harmful effect.
5	Protected against water jets	Water projected by a nozzle against the enclosure from any direction is to have no harmful effect.
6	Protected against heavy seas	Water from heavy seas or water projected in powerful jets is not to enter the enclosure in harmful quantities.
7	Protected against the effects of immersion	Ingress of water in a harmful quantity is not to be possible when the enclosure is immersed in water under defined conditions of pressure and time.
8	Protected against submersion	The equipment is suitable for continuous submersion in water under conditions which are to be specified by the manufacturer. <i>Note:</i> Normally this will mean that the equipment is hermetically sealed. However, with certain types of equipment, it can mean that water can enter but only in such a manner that it produces no harmful effects.
9	Protected against high pressure and temperature water jets	Water projected at high pressure and high temperature against the enclosure from any direction shall not have harmful effects

TABLE 2
Minimum Degree of Protection
(For high voltage equipment, see 4-8-5/Table 1)

Example of Location	Condition of Location	Switchboards, Distribution Boards, Motor Control Centers and Controllers						
		Generators						Accessories ⁽²⁾
		Motors						
		Transformers, Converters						
		Lighting Fixtures						
Heating Appliances								
Dry accommodation space	Danger of touching live parts only	IP20	-	IP20	IP20	IP20	IP20	IP20
Dry control rooms ⁽⁴⁾		IP20	-	IP20	IP20	IP20	IP20	IP20
Control rooms	Danger of dripping liquid and/or moderate mechanical damage	IP22	-	IP22	IP22	IP22	IP22	IP22
Machinery spaces above floor plates ⁽⁵⁾		IP22	IP22	IP22	IP22	IP22	IP22	IP44
Steering gear rooms		IP22	IP22	IP22	IP22	IP22	IP22	IP44
Refrigerating machinery rooms		IP22	-	IP22	IP22	IP22	IP22	IP44
Emergency machinery rooms		IP22	IP22	IP22	IP22	IP22	IP22	IP44
General store rooms		IP22	-	IP22	IP22	IP22	IP22	IP22
Pantries		IP22	-	IP22	IP22	IP22	IP22	IP44
Provision rooms		IP22	-	IP22	IP22	IP22	IP22	IP22
Bathrooms and Showers	Increased danger of liquid and/or mechanical damage	-	-	-	-	IP34	IP44	IP55
Machinery spaces below floor plates		-	-	IP44	-	IP34	IP44	IP55 ⁽³⁾
Closed fuel oil or lubricating oil separator rooms		IP44	-	IP44	-	IP34	IP44	IP55 ⁽³⁾
Ballast pump rooms	Increased danger of liquid and mechanical damage	IP44	-	IP44	IP44	IP34	IP44	IP55
Refrigerated rooms		-	-	IP44	-	IP34	IP44	IP55
Galleys and Laundries		IP44	-	IP44	IP44	IP34	IP44	IP44 ⁽⁶⁾
Shaft or pipe tunnels in double bottom	Danger of liquid spray presence of cargo dust, serious mechanical damage, and/or aggressive fumes	IP55	-	IP55	IP55	IP55	IP55	IP56
Holds for general cargo		-	-	-	-	IP55	-	IP55
Open decks	Exposure to heavy seas	IP56	-	IP56	-	IP55	IP56	IP56
Bilge wells	Exposure to submersion	-	-	-	-	IPX8	-	IPX8

Notes:

- Empty spaces shown with “-” indicate installation of electrical equipment is not recommended.
- “Accessories” include switches, detectors, junction boxes, etc.
- Socket outlets are not to be installed in machinery spaces below the floor plate, enclosed fuel and lubricating oil separator rooms. Plugs and sockets that are present in a hazardous area are to be certified for use in the particular zone.
- For the purpose of this Table, the wheelhouse may be categorized as a “dry control room” and consequently, the installation of IP20 equipment would suffice therein provided that: (a) the equipment is located as to preclude being exposed to steam, or dripping/spraying liquids emanating from pipe flanges, valves, ventilation ducts and outlets, etc., installed in its vicinity, and (b) the equipment is placed to preclude the possibility of being exposed to sea or rain.
- See 4-8-3/1.11.2 where the equipment is located within areas protected by local fixed pressure water-spraying or water-mist fire extinguishing system and its adjacent areas.
- Socket outlets in galleys and laundries are to maintain their protection against splashed water when not in use.

TABLE 3
Factory Test Schedule for Generators and Motors ≥ 100 kW (135 hp)

Tests (see 4-8-3/3.15)		AC Generators		AC Motors		DC Machines	
		Type Test ⁽¹⁾	Routine Test ⁽²⁾	Type Test ⁽¹⁾	Routine Test ⁽²⁾	Type Test ⁽¹⁾	Routine Test ⁽²⁾
1	Visual inspection.	x	x	x	x	x	x
2	Insulation resistance measurement, see 4-8-3/3.15.2.	x	x	x	x	x	x
3	Winding resistance measurement, see 4-8-3/3.15.3.	x	x	x	x	x	x
4	Verification of voltage regulation system, see 4-8-3/3.15.4.	x	x ⁽³⁾				
5	Rated load test and temperature rise measurement, see 4-8-3/3.15.5.	x		x		x	
6	Overload/overcurrent test, see 4-8-3/3.15.6.	x	x ⁽⁴⁾	x	x ⁽⁴⁾	x	x ⁽⁴⁾
7	Verification of steady short-circuit condition, see 4-8-3/3.15.7. ⁽³⁾	x					
8	Overspeed test, see 4-8-3/3.15.8.	x	x	x ⁽⁶⁾	x ⁽⁶⁾	x ⁽⁶⁾	x ⁽⁶⁾
9	Dielectric strength test, see 4-8-3/3.15.9.	x	x	x	x	x	x
10	Running balance test, see 4-8-3/3.15.10 ⁽⁷⁾	x	x	x	x	x	x
11	Verification of degree of protection.	x		x		x	
12	Bearing check after test.	x	x	x	x	x	x
13	Air gap measurement.	x	x			x	x
14	Commutation check.					x	

Notes

- 1 Type tests applies to prototype machines or to at least the first of a batch of machines.
- 2 Machines to be routine tested are to have reference to the machine of the same type that has passed a type test. Reports of routine tested machines are to contain manufacturers' serial numbers of the type tested machines and the test results.
- 3 Only functional test of voltage regulator system.
- 4 Applicable only to generators and motors ≥ 100 kW (135 hp) for essential services.
- 5 Verification at steady short-circuit condition applies to synchronous generators only.
- 6 Where so specified and agreed upon between purchaser and manufacturer. Not required for squirrel cage motors.
- 7 Static balance (machine rated 500 rpm or less) or dynamic balance (over 500 rpm) will be accepted in lieu of the specified test on machines to be close-coupled to engines and supplied without shaft and/or bearings, or with incomplete set of bearings.

TABLE 4
Limit of Temperature Rise for Air Cooled Rotating Machines

Ambient temperature = 45°C

Item No.	Part of Machine	Temperature Measuring Method	Limit of Temperature Rise, °C for Class of Insulation				
			A	E	B	F	H
1	a) AC windings of machines having rated output of 5,000 kW (or kVA) or more	Resistance	55	-	75	95	120
		Embedded temp. detector	60	-	80	100	125
	b) AC windings of machines having rated output above 200 kW (or kVA) but less than 5,000 kW (or kVA)	Resistance	55	70	75	100	120
		Embedded temp. detector.	60	-	85	105	125
	c) AC windings of machines having rated outputs of 200 kW (or kVA) or less ⁽¹⁾	Resistance	55	70	75	100	120
		Thermometer	45	60	65	80	100
2	Windings of armatures having commutators	Resistance	55	70	75	100	120
		Thermometer	45	60	65	80	100
3	Field windings of AC and DC machines having DC excitation, other than those in item 4	Resistance	55	70	75	100	120
		Thermometer	45	60	65	80	100
4	a) Field winding of synchronous machines with cylindrical rotors having DC excitation winding embedded in slots, except synchronous induction motors	Resistance	-	-	85	105	130
		Thermometer	45	60	65	80	100
	b) Stationary field windings of AC machines having more than one layer	Resistance	55	70	75	100	120
		Embedded temp. detector.	-	-	85	105	130
		Thermometer	55	70	75	95	120
	c) Low resistance field winding of AC and DC machines and compensating windings of DC machines having more than one layer	Resistance	55	70	75	95	120
		Thermometer	60	75	85	105	130
	d) Single-layer windings of AC and DC machines with exposed bare or varnished metal surfaces and single layer compensating windings of DC machines ⁽²⁾	Resistance	60	75	85	105	130
		Thermometer	60	75	85	105	130
	5	Permanently short-circuited windings					
6	Magnetic cores and all structural components, whether or not in direct contact with insulation (excluding bearings)	The temperature rise of any parts is not to be detrimental to the insulating of that part or to any other part adjacent to it.					
7	Commutators, slip-rings and their brushes and brushing	The temperature rise of any parts is not to be detrimental to the insulating of that part or to any other part adjacent to it. Additionally, the temperature is not to exceed that at which the combination of brush grade and commutator/slip-ring materials can handle the current over the entire operating range.					

Notes

- 1 With application of the superposition test method to windings of machines rated 200 kW (or kVA) or less with insulation classes A, E, B or F, the limits of temperature rise given for the resistance method may be increased by 5°C.
- 2 Also includes multiple layer windings provided that the under layers are each in contact with the circulating coolant.

TABLE 5
Equipment and Instrumentation for Switchboards

<i>Instrumentation and Equipment</i>	<i>Alternating-current (AC) Switchboard</i>	<i>Direct-current (DC) Switchboard</i>
1. Indicator light	An indicator light for each generator, connected between generator and circuit breaker. ⁽³⁾	An indicator light for each generator, connected between generator and circuit breaker.
2. Generator Disconnect	A generator switch or disconnecting links in series with the generator circuit breaker which is to disconnect completely all leads of the generator and the circuit breaker from the buses, except the earth lead. ⁽¹⁾	A generator switch, or disconnecting links, in series with the circuit breaker which will open positive, negative, neutral and equalizer leads, except that for 3-wire generators, equalizer poles may be provided on the circuit breaker. For 3-wire generators, the circuit breakers are to protect against a short circuit on the equalizer buses. ⁽¹⁾
3. Insulation Monitor and Alarm	A means for continuously monitoring the electrical insulation level to earth, and an audible or visual alarm for abnormally low insulation values. ⁽³⁾⁽⁵⁾	A means for continuously monitoring the electrical insulation level to earth, and an audible or visual alarm for abnormally low insulation values. ⁽³⁾
4. Ammeter	An ammeter for each generator with a selector switch to read the current of each phase. ⁽³⁾	An ammeter for each 2-wire generator. For each 3-wire generator, an ammeter for each positive and negative lead and a center-zero ammeter in the earth connection at the generator switchboard. Ammeters are to be so located in the circuit as to indicate total generator current.
5. Voltmeter	A voltmeter for each generator, with a selector switch to each phase of the generator and to one phase of the bus. ⁽³⁾	A voltmeter for each generator with voltmeter switch for connecting the voltmeter to indicate generator voltage and bus voltage. For each 3-wire generator, a voltmeter with voltmeter switch for connecting the voltmeter to indicate generator voltage, positive to negative, and bus voltage positive to negative, positive to neutral, and neutral to negative. Where permanent provisions for shore connections are fitted, one voltmeter switch to provide also for reading shore-connection voltage, positive to negative
6. Space heater indicator light	Where electric heaters are provided for generators, a heater indicator light is to be fitted for each generator.	Where electric heaters are provided for generators, a heater indicator light is to be fitted for each generator.
7. Synchroscope or Lamps	A synchroscope or synchronizing lamps with selector switch for paralleling in any combination ⁽³⁾	Not applicable
8. Prime mover Speed Control	Control for prime mover speed for paralleling ⁽³⁾	Not applicable
9. Wattmeter	Where generators are arranged for parallel operation, an indicating wattmeter is to be fitted for each generator. ⁽³⁾	Not applicable
10. Frequency Meter	A frequency meter with selector switch to connect to any generator. ⁽³⁾	Not applicable
11. Field Switch	A double-pole field switch with discharge clips and resistor for each generator. ⁽²⁾	Not applicable
12. Voltage Regulator	A voltage regulator. ⁽³⁾	Not applicable
13. Stator Winding Temperature Indicator	For alternating current propulsion generator above 500 kW, a stator winding temperature indicator is to be fitted for each generator control panel. ⁽³⁾⁽⁴⁾	For direct current propulsion generator above 500 kW, an interpole winding temperature indicator is to be fitted for each generator control panel. ⁽³⁾⁽⁴⁾

continued...

TABLE 5 (continued)
Equipment and Instrumentation for Switchboards

Notes

- 1 The switch or links may be omitted when draw-out or plug-in mounted generator breakers are furnished.
- 2 For generators with variable voltage exciters or rotary rectifier exciters, each controlled by voltage-regulator unit acting on the exciter field, the field switch and the discharge resistor may be omitted.
- 3 Where vessels have centralized control systems in accordance with Part 4, Chapter 9 and the generators can be paralleled from the centralized control station, and the switchboard is located in the centralized control station, this equipment may be mounted on the control console. See 4-8-3/5.5.4.
- 4 For high voltage systems, see also 4-8-5/3.7.3(c).
- 5 For high voltage systems, see 4-8-5/3.3.2.

TABLE 6
Maximum Current Carrying Capacity for Cables

Conductor Size		Maximum Current in Amperes (see 4-8-3/9.3) 45°C (113°F) Ambient; 750 V and Less, AC or DC; see Notes											
mm ²	10 ³ circ mils	1-core				2-core				3- or 4-core			
		V75	R85 XLPE E85 EPR	R90 XLPE E90 EPR	M95 S95	V75	R85 XLPE E85 EPR	R90 XLPE E90 EPR	M95 S95	V75	R85 XLPE E85 EPR	R90 XLPE E90 EPR	M95 S95
1.0		13	16		20	11	14		17	9	11		14
1.25		15	18		23	13	15		20	11	13		16
1.5		17	21	23	26	14	18	20	22	12	15	16	18
	4.11	21	25		32	18	21		27	15	18		22
2.5		24	28	30	32	20	24	26	27	17	20	21	22
	6.53	28	34		38	24	29		32	20	24		27
4		32	38	40	43	27	32	34	37	22	27	28	30
	10.4	38	45		51	32	38		43	27	32		36
6		41	49	52	55	35	42	44	47	29	34	36	39
	16.5	51	60		68	43	51		58	36	42		48
10		57	67	72	76	48	57	61	65	40	47	50	53
	20.8	59	70		78	50	60		66	41	49		55
	26.3	68	81		91	58	69		77	48	57		64
16		76	91	96	102	65	77	82	87	53	64	67	71
	33.1	79	93		105	67	79		89	55	65		74
	41.7	91	108		121	77	92		103	64	76		85
25		101	120	127	135	86	102	108	115	71	84	89	95
	52.6	105	124		140	89	105		119	74	87		98
	66.4	121	144		162	103	122		138	85	101		113
35		125	148	157	166	106	126	133	141	88	104	110	116
	83.7	140	166		187	119	141		159	98	116		131
50		156	184	196	208	133	156	167	177	109	129	137	146
	106	163	193		217	139	164		184	114	135		152
	133	188	222		250	160	189		213	132	155		175
70		192	228	242	256	163	194	206	218	134	160	169	179
	168	217	257		289	184	218		246	152	180		202
95		232	276	293	310	197	235	249	264	162	193	205	217
	212	251	297		335	213	252		285	176	208		235
120		269	319	339	359	229	271	288	305	188	223	237	251
	250	278	330		371	236	281		315	195	231		260
150		309	367	389	412	263	312	331	350	216	257	272	288
	300	312	370		416	265	315		354	218	259		291
	350	343	407		458	292	346		389	240	285		321
185		353	418	444	470	300	355	377	400	247	293	311	329
	400	373	442		498	317	376		423	261	309		349
	450	402	476		536	342	405		456	281	333		375
240		415	492	522	553	353	418	444	470	291	344	365	387
	500	429	509		572	365	433		486	300	356		400
	550	455	540		607	387	459		516	319	378		425
300		477	565	601	636	405	480	511	541	334	396	421	445
	600	481	570		641	409	485		545	337	399		449
	650	506	599		674	430	509		573	354	419		472
	700	529	628		706	450	534		600	370	440		494
	750	553	655		737	470	557		626	387	459		516

TABLE 6 (continued)
Maximum Current Carrying Capacity for Cables

Conductor Size		Maximum Current in Amperes (see 4-8-3/9.3) 45°C (113°F) ambient; 750 V and less, AC or DC; see Notes											
		1-core				2-core				3- or 4-core			
mm ²	10 ³ circ mils	V75	R85 XLPE	R90 XLPE	M95	V75	R85 XLPE	R90 XLPE	M95	V75	R85 XLPE	R90 XLPE	M95
			E85 EPR	E90 EPR	S95		E85 EPR	E90 EPR	S95		E85 EPR	E90 EPR	S95
400		571	677	690	761	485	575	587	647	400	474	483	533
	800	576	682		767	490	580		652	403	477		540
	850	598	709		797	508	603		677	419	496		558
	900	620	734		826	527	624		702	434	514		578
	950	641	760		854	545	646		726	449	532		598
500		656	778	780	875	558	661	663	744	459	545	546	613
	1000	662	784		882	563	666		750	463	549		617
600		736	872		981	626	741		834	515	610		687
625		755	894		1006	642	760		855	529	626		704

Notes to Table 6

- 1 The nomenclature of cable insulation types used in 4-8-3/Table 6 is as follows:

Insulation Type Designation		Insulation Materials	Maximum Conductor Temperature, °C
IEC 60092-353	IEC 60092-3		
---	V75	Polyvinyl chloride – heat resisting	75
XLPE	R85	Cross-linked polyethylene	85
EPR	E85	Ethylene propylene rubber	85
XLPE	R90	Cross-linked polyethylene	90
EPR	E90	Ethylene propylene rubber	90
---	M95	Mineral (MI)	95
S95	S95	Silicone rubber	95

- 2 The maximum current values given in 4-8-3/Table 6 have been derived from IEC Publication 60092-353 and are based on ambient temperature of 45°C and on the assumption that when a group of four cables bunched together and laid in free air, the conductors will attain and operate continuously at a temperature equal to the maximum rated temperature of the insulation.
- 3 The maximum current values given in 4-8-3/Table 6 (and those derived therefrom) may be used, without correction factors, for cables installed double-banked in cable conduits or cable pipes, except as noted in Note (4).
- 4 Where more than six cables expected to be operated simultaneously are laid together in a bunch in such a way that there is an absence of free air circulation around them, a correction factor of 0.85 is to be applied to the values given in 4-8-3/Table 6.
- 5 The maximum current values given in 4-8-3/Table 6 are applicable to both armored and unarmored cables.
- 6 If ambient temperature differs from 45°C, the maximum current values in 4-8-3/Table 6 are to be multiplied by the following factors:

Maximum Conductor Temperature	Ambient Correction Factor					
	40°C	50°C	55°C	60°C	65°C	70°C
75°C	1.08	0.91	0.82	0.71	0.58	---
85°C	1.06	0.94	0.87	0.79	0.71	0.61
90°C	1.05	0.94	0.88	0.82	0.74	0.67
95°C	1.05	0.95	0.89	0.84	0.77	0.71

TABLE 6 (continued)
Maximum Current Carrying Capacity for Cables

7 Where the number of conductors in a cable exceeds 4, the maximum current value is to be corrected by factors as indicated in the following table:

<i>No. of Conductors</i>	<i>Correction Factor for 3- or 4-Core Values in Table 6</i>
5 – 6	0.8
7 – 24	0.7
25 – 42	0.6
≥ 43	0.5

8 When a mineral-insulated cable is installed in such a location that its copper sheath is liable to be touched when in service, the current rating is to be multiplied by the correction factor 0.80 in order that the sheath temperature does not exceed 70°C.

9 Cables being accepted based on approved alternate standard may have current carrying capacity of that standard provided the cables are in full compliance with that standard.

TABLE 7
Additional Services Requiring Electrical Equipment to be Designed, Constructed and Tested to the Requirements in Section 4-8-3
[See 4-8-1/5.5, 4-8-3/1.5, 4-8-3/3.1, 4-8-3/3.15.1, 4-8-3/3.17 and 4-8-3/5.11.1]

(a)	Equipment necessary for specific class notations (Such as refrigerated cargo notations, dynamic positioning systems, etc.)
(b)	Cargo Pump Motors (oil carriers, gas carriers, chemical carriers, liquefied gas carriers, etc.)
(c)	Motors for hydraulic power unit for hydraulically driven cargo pump motors
(d)	High duty gas compressors on liquefied gas carriers

4

CHAPTER 8 Electrical Systems

SECTION 4 Shipboard Installation and Tests

1 General

1.1 Application

The provisions of this section apply to all electrical installations onboard vessels. Additional requirements applicable to high voltage systems and electric propulsion systems are given in Section 4-8-5. Requirements applicable to specific vessel types, particularly with regard to installations in hazardous areas, are given in Part 5C and Part 5D.

1.3 Degree of Enclosure

Electrical equipment is to be protected from the intrusion of foreign matter during service. For this purpose the degree of enclosure of electrical equipment is to be adequate for its location of installation. The minimum degrees of enclosure required for typical locations onboard vessels are given in 4-8-3/Table 2 and are to be complied with.

For electrical and electronic equipment located within areas protected by Local Fixed Pressure Water-spraying or Water-mist Fire Extinguishing System and in adjacent areas where water may extend, see 4-8-3/1.11.2.

1.5 Hazardous Areas

Areas where flammable or explosive gases, vapors or dust are normally or likely to be present are known as hazardous areas. Electrical equipment intended for installation in hazardous areas are to have suitable enclosures or are to be of the low energy type. See 4-8-4/27.

1.7 Inclination

Electrical equipment is to be installed such that its inclination, in both the longitudinal and athwartship directions, and in static and dynamic operating conditions, will not exceed that to which it is designed, and in any case, is to operate satisfactorily up to the inclinations defined in 4-1-1/7.9.

1.9 Services Required to be Operable Under a Fire Condition

For the purpose of 4-8-4/21.17.2, services required to be operable under a fire condition include, but not limited thereto, are the following:

- i) Fire and general alarm system
- ii) Fire extinguishing system including fire extinguishing medium release alarms
- iii) Emergency Fire Pump
- iv) Fire detection system
- v) Control and power systems for all power operated fire doors and their status indicating systems
- vi) Control and power systems for all power operated watertight doors and their status indicating systems
- vii) Emergency lighting
- viii) Public address system

- ix) Remote emergency stop/shutdown arrangement for systems which may support the propagation of fire and/or explosion
- x) For passenger vessels, see 5C-7-5/13.7.2(b).

1.11 High Fire Risk Areas

For the purpose of 4-8-4/21.17, the examples of the high fire risk areas are the following:

- i) Machinery spaces as defined by 4-7-1/11.15 and 4-7-1/11.17, except spaces having little or no fire risk such as machinery spaces which do not contain machinery having a pressure lubrication system and where storage of combustibles is prohibited (e.g., ventilation and air-conditioning rooms, windlass room, steering gear room, stabilizer equipment room, electrical propulsion motor room, rooms containing section switchboards and purely electrical equipment other than oil-filled electrical transformers (above 10 kVA), shaft alleys and pipe tunnels, and spaces for pumps and refrigeration machinery not handling or using flammable liquids).
- ii) Spaces containing fuel treatment equipment and other highly flammable substances
- iii) Galley and pantries containing cooking appliances
- iv) Laundry containing drying equipment
- v) For passenger vessels, see 5C-7-5/13.7.2(c).

1.13 Installation Requirements for Recovery from Dead Ship Condition

Means are to be provided to ensure that machinery can be brought into operation from the dead ship condition without external aid. See 4-1-1/1.9.6.

Where the emergency source of power is an emergency generator which complies with 4-8-2/5.15 and 4-8-2/3.1.3, this emergency generator may be used for restoring operation of the main propulsion plant, boilers and auxiliary machinery.

Where there is no emergency generator installed, the arrangements for bringing main and auxiliary machinery into operation are to be such that the initial charge of starting air or initial electrical power and any power supplies for engine operation can be developed onboard ship without external aid. If for this purpose an emergency air compressor or an electric generator is required, these units are to be powered by a hand-starting oil engine or a hand-operated compressor.

The arrangements for bringing the main and auxiliary machinery into operation are to have a capacity such that the starting energy and any power supplies for propulsion engine operation are available within 30 minutes of a blackout condition.

3 Generators and Motors

Generators, motors and other rotating machines are to be installed preferably with their shafts in a fore-and-aft direction of the vessel and are to operate satisfactorily in accordance with the inclination requirements of 4-1-1/7.9. Where it is not practicable to mount the generators with the armature shafts in the fore-and-aft direction, their lubrication will require special consideration. Arrangements are to be made to protect generator and motors from bilge water. Precautions are also to be taken to preclude any oil which may escape under pressure from entering machine windings.

5 Accumulator Batteries

5.1 General

5.1.1 Application

These requirements are applicable to batteries which emit hydrogen while in use. Designs and construction standards of other battery types are to be submitted for consideration in each case along with operational hazards of the batteries.

Installation design of other battery types is to be submitted for consideration in each case along with operational hazards of the batteries.

5.1.2 Battery Cells

Battery cells are to be so constructed as to prevent spillage of electrolyte due to motions of the vessel at sea. Batteries are to be secured to their trays or shelves to prevent their movement.

5.1.3 Nameplate

Nameplates of corrosion-resistant material are to be provided in an accessible position of the trays or shelves and are to indicate at least the following information:

- The manufacturer's name
- The type designation
- The rated voltage
- The ampere-hour rating at a specific rate of discharge
- The specific gravity of the electrolyte (in the case of a lead-acid battery, the specific gravity when the battery is fully charged)

5.1.4 Referenced Requirements

The following requirements are also applicable to battery installations:

- Accumulator batteries as emergency source of electrical power 4-8-2/5.9.2
- Accumulator batteries as transitional source of electrical power 4-8-2/5.11
- Protection of accumulator batteries 4-8-2/9.15
- Battery starting systems 4-8-2/11.11

5.1.5 Maintenance of Batteries

5.1.5(a) Maintenance Schedule of batteries. Where batteries are fitted for use for essential and emergency services, a maintenance schedule of such batteries is to be provided and maintained. The schedule is to include at least the following information regarding the batteries, which is to be submitted for review, during their plan approval or the new building survey.

- Type and manufacturer's type designation.
- Voltage and ampere-hour rating.
- Location.
- Equipment and/or system(s) served.
- Maintenance/replacement cycle dates.
- Date(s) of last maintenance and/or replacement.
- For replacement batteries in storage, the date of manufacture and shelf life (See Note below)

Note: Shelf life is the duration of storage under specified conditions at the end of which a battery retains the ability to give a specified performance.

5.1.5(b) Procedure of maintenance. Procedures are to be put in place to show that, where batteries are replaced, they are to be of an equivalent performance type. Details of the schedule, procedures, and the maintenance records are to be included in the ship's safety management system and integrated into the ship's operational maintenance routine, as appropriate, which are to be verified by the Surveyor.

5.1.6 Replacement of Batteries

Where a vented type battery (See Note 1) replaces a valve-regulated, sealed type battery (See Note 2), the requirements in 4-8-4/5.3 are to be complied with on the basis of the charging capacity.

Notes:

- 1 A vented battery is one in which the cells have a cover provided with an opening through which products of electrolysis and evaporation are allowed to escape freely from the cells to atmosphere.
- 2 A valve-regulated battery is one in which cells are closed but have an arrangement (valve) which allows the escape of gas if the internal pressure exceeds a predetermined value.

5.3 Lead-acid or Alkaline Battery Storage Locations

5.3.1 Battery Room

5.3.1(a) General. Where a group of accumulator batteries is connected to charging devices with total output of more than 2 kW, it is to be installed in a battery room dedicated to batteries only. No other electrical equipment is to be installed in the battery room except that necessary for operational purposes. Each of such equipment is to be of a certified safe type for battery room atmosphere. See also 4-8-4/27.5.3.

5.3.1(b) Ventilation of battery room. Battery room is to be ventilated to avoid accumulation of flammable gas. Natural ventilation may be employed if ducts can be led directly from the top of the battery room to the open air above, with an opening for air inlet near the floor.

If natural ventilation is impractical, mechanical exhaust ventilation is to be provided with fan intake at the top of the room. Fan motor is to be of certified safe type, and fan is to be of non-sparking construction (see 4-8-3/11). The fan is to be capable of completely changing the air in the battery room in not more than two minutes. An alternative fan capacity may be provided if it is able to maintain the flammable gases within the battery room to a level below the lower explosive limit (L.E.L.) at the maximum battery charging current. Where the ventilation capacity is based on low-hydrogen emission type batteries (see also 4-8-4/5.5), a warning notice to this effect is to be displayed in a visible place in the battery room. Openings for air inlet are to be provided near the floor.

5.3.1(c) Corrosion protection in battery room. Interior of the battery room including structural members, shelves, ventilation inlets and outlets are to be coated with paint resistant to the electrolyte used in the batteries. Shelves for lead acid batteries are to have watertight lining of sheet lead not less than 1.6 mm ($1/8$ in.) thick, and carried up not less than 75 mm (3 in.) on all sides; and that for alkaline batteries of sheet steel not less than 0.8 mm ($1/16$ in.) thick. Alternatively, the entire battery room may be fitted with a watertight lead pan (or steel for alkaline batteries), over the entire deck, carried up not less than 150 mm (6 in.) on all sides.

5.3.1(d) Battery trays. For purposes of heat dissipation during equalizing charge, appropriate air spaces are to be provided around each battery. Where placed in trays, batteries are to be chocked with wood strips or equivalent to prevent movement and each battery is to be supported in the tray with nonabsorbent insulator on the bottom and at the sides or with equivalent provision to secure air-circulation space all around each tray.

5.3.2 Deck Boxes

5.3.2(a) General. Where a group of accumulator batteries is connected to a charging devices with a total output of 0.2 kW up to and including 2 kW, they may be installed in the battery room or, alternatively, in deck boxes. Deck boxes may be located in machinery spaces, or other well ventilated locations.

5.3.2(b) Ventilation of deck boxes. Deck boxes are to be provided with a duct from the top of the box, terminating with a means to prevent entrance of water such as goose-neck or mushroom head. At least two air inlets are to be provided at the lower part and opposite sides of the deck box. Louvers or equivalent are to be fitted at the air inlets at the lower part of the box. Where located in the weather, deck boxes, including openings for ventilation, are to be weathertight.

5.3.2(c) Corrosion protection in deck boxes. Deck boxes are to be fitted with watertight trays with coaming heights not less than 150 mm (6 in.) as in 4-8-4/5.3.1(c).

5.3.3 Small Battery Boxes

Batteries not covered in 4-8-4/5.3.1 and 4-8-4/5.3.2 are to be installed in battery boxes and may be located as desired, except they are not to be located in sleeping quarters unless hermetically sealed. Small battery boxes require no ventilation other than openings near the top to allow escape of gas. For corrosion protection, the boxes are to be lined to a depth of 75 mm (3 in.) consistent with the method in 4-8-4/5.3.1(c).

5.3.4 Batteries for Engine Starting

Engine starting batteries are to be installed in the same space where the engine is installed, and are to be located close to the engine.

5.3.5 Batteries of Different Electrolyte

Where batteries of different types, for which different electrolyte are used, are installed in the same room, they are to be segregated and effectively identified.

5.3.6 Summary

The battery storage requirements in 4-8-4/5.3.1 to 4-8-4/5.3.3 are summarized below:

Battery Chargers with Total Output (P) of:	Acceptable Battery Spaces/Enclosures			
	Battery Room	Deck Box	Small Battery Box	Small Battery Box Located in Sleeping Quarters
$P > 2 \text{ kW}$	Yes	No	No	No
$0.2 \text{ kW} \leq P \leq 2 \text{ kW}$	Yes	Yes	No	No
$P < 0.2 \text{ kW}$	n/a	Yes	Yes	No
$P < 0.2 \text{ kW}$ and when Battery is hermetically sealed	n/a	Yes	Yes	Yes

Note: For low hydrogen emission batteries see 4-8-4/5.5.

5.5 Low-hydrogen-emission Battery Storage Locations

A battery is considered low-hydrogen-emission (LHE) if it does not emit more hydrogen under similar charging condition than a standard lead-acid battery. LHE batteries connected to charging devices with total output of more than 2 kW may be installed as in 4-8-4/5.3.2, provided calculations are submitted demonstrating that under a similar charging condition, hydrogen emission does not exceed that of standard lead-acid batteries connected to a 2 kW charging device. Similarly, LHE batteries connected to charging device with total output of 2 kW or less may be installed as in 4-8-4/5.3.3, provided calculations are submitted demonstrating that under a similar charging condition, hydrogen emission does not exceed that of standard lead-acid batteries connected to charging device of 0.2 kW.

For such installations, a warning-notice is to be displayed to notify maintenance personnel that additional batteries are not to be installed and any replacement battery is to be of the LHE type.

7 Switchboard and Distribution Boards

7.1 Switchboard

7.1.1 Location and Clearance for Maintenance

Switchboards are to be secured to a solid foundation. They are to be self-supported or be braced to the bulkhead or the deck above. In case the last method is used, means of bracing is to be flexible to allow deflection of the deck without buckling the assembly structure.

Switchboards are to be so arranged as to give easy access as may be needed to apparatus and equipment, without danger to personnel. Switchboards are to be located in a dry place. Clear working space of at least 900 mm (35 in.) at the front of the switchboard and a clearance of at least 600 mm (24 in.) at the rear are to be provided. The clearance at the rear may be reduced to 457 mm (18 in.) in way of stiffeners or frames so long as they do not impair the operability and serviceability of the switchboards. For switchboards enclosed at the rear and fully serviceable from the front, clearance at the rear will not be required, except that necessary for cooling.

7.1.2 Precaution Against Electrical Shock

Unless the switchboard is installed on an electrically-insulated floor, non-conducting mats or gratings are to be provided at the front and the rear of switchboards where operations or maintenance are expected. Where the floor on which the switchboard is installed is of electrically-insulated construction, the insulation level of the floor to the earth is to be at least 50 MΩ. A notice plate is to be posted at the entrance to the switchboard room or on the switchboard front panel to state that the floor in the room is of electrically-insulated construction.

7.1.3 Protection for Leakage of Liquid

Pipes are not to be routed in the vicinity of switchboards. Where this cannot be avoided, such piping is to be of all welded joints or means are to be provided to prevent any joint leakage under pressure to impinge on the switchboard.

7.3 Distribution Boards

7.3.1 Location and Protection

Distribution boards are to be installed in accessible locations, but not in such spaces as bunkers, storerooms or, cargo holds. Distribution boards may be located behind panels/linings within accommodation spaces, including stairway enclosures, without the need to categorize the space for fire integrity standard, provided no provision is made for storage.

7.3.2 Switchboard-type Distribution Boards

Distribution boards of the switchboard type, unless installed in machinery spaces or in compartments assigned exclusively to electric equipment and accessible only to authorized personnel, are to be completely enclosed or protected against accidental contact and unauthorized operation.

7.3.3 Safety-type Panels

Unless installed in machinery spaces or in compartments assigned exclusively to electric equipment and accessible only to authorized personnel, the distribution boards are to be of the safety type. This type of distribution boards are to be used for controlling branch lighting circuits. Dead front type panels are to be used where voltage to earth is in excess of 50 volts DC or 50 volts AC rms between conductors.

9 Motor Controllers and Motor Control Centers

9.1 Location

Motor control centers are to be located in a dry place. Clear working space is to be provided around motor control centers to enable doors to be fully opened and equipment removed for maintenance and replacement. Motor control centers are to be secured to a solid foundation, be self-supported or be braced to the bulkhead.

9.3 Disconnecting Arrangements

9.3.1 General

A circuit-disconnecting device is to be provided for each branch circuit of motor rated 0.5 kW or above so that the motor and the controller may be isolated from the power supply for maintenance purposes. However, for a pre-assembled or skid-mounted unit having two or more motors (e.g., fuel oil blender), a single disconnecting device in its feeder may be accepted in lieu of individual disconnecting devices for the motors, provided that the full load current of each motor is less than 6 A. See also 4-8-3/5.7.2.

9.3.2 Location of the Disconnecting Device

The disconnecting device may be in the same enclosure with the controller, in which case it is to be externally operable. The branch-circuit switch or circuit breaker on the power-distribution panel or switchboard may serve as the disconnect device if it is located in the same compartment as the controller. In any case, if the disconnecting device is not within sight of both the motor and the controller, or if it is more than 15 m (50 ft) from either, it is to be arranged for locking in the open position. The disconnect switch, if not adjacent to the controller, is to be provided with an identification plate.

9.3.3 Open/Close Indication

The disconnect device is to be provided with an indication of whether it is open or closed.

9.3.4 Supply Voltage of Indicating Light Circuit

Where the indicating light is fitted to a motor controller to indicate the availability of the power supply, and if the required disconnecting device does not de-energize the indicating light circuits, the voltage of indicating light circuits is not to exceed 150 V.

9.5 Resistors for Control Apparatus

Controllers fitted with resistors are to be located in well-ventilated compartments and are to be mounted with ample clearances [about 300 mm (12 in.)] from vessel structures and unprotected combustible materials.

11 Lighting Systems

11.1 General

11.1.1 Hot Surfaces

Lighting fixtures are to be so installed as to prevent their hot surfaces from damaging cables and wiring, and from igniting surrounding materials.

11.1.2 Referenced Requirements

The following referenced requirements are applicable:

- Emergency lighting 4-8-2/5.5.1 and 4-8-2/5.5.2
- Lighting system arrangement 4-8-2/7.13
- Cable for branch lighting circuit 4-8-2/7.7.7
- Protection of branch lighting circuit 4-8-2/9.21
- Wiring insulation within fluorescent light fixtures 4-8-4/21.1.8

11.3 Lighting Installation in Cargo Spaces

Fixed lighting circuits in the bunker or cargo spaces are to be controlled by multipole-linked switches situated outside the bunker or cargo spaces.

11.5 Lighting Distribution Boards

To prevent the simultaneous loss of main and emergency lighting distribution boards due to localized fire or other casualty, these distribution boards are to be installed as widely apart as practicable in the machinery spaces.

For spaces other than the machinery space (e.g., accommodation space, ro-ro cargo spaces, etc.), these lighting distribution boards are to be installed at locations which are separated by a boundary wall. The boundary wall separation is to be a non-combustible partition complying with as a minimum a C-class panel division.

For the navigation bridge, the main and emergency lighting distribution boards are not to be installed in the same compartment of the navigation console or panel

Cables emanating from the main or emergency lighting switchboard to the main or emergency lighting distribution board, respectively, are also to be installed as widely apart as practicable. See also 4-8-2/7.13.2.

13 Heating Equipment

13.1 Electric Radiators

Electric radiators, if used, are to be fixed in position and be so constructed as to reduce fire risks to a minimum. Electric radiators of the exposed-element type are not to be used.

15 Magnetic Compasses

Precautions are to be taken in connection with apparatus and wiring in the vicinity of the magnetic compass to prevent disturbance of the needle from external magnetic fields.

17 Portable Equipment and Outlets

Portable apparatus served by a flexible cord is not to be used in cargo oil pump rooms or other hazardous areas.

19 Power Receptacles

Receptacles and plugs of different voltage systems are not to be interchangeable, e.g., receptacles for 230 V system are to be of a type which will not permit attaching 115 V equipment.

21 Cable Installation

21.1 General Requirements

21.1.1 Continuity

Electrical cables are to be installed, as far as practicable, in continuous lengths between termination points. Where necessary, the use of cable junction boxes will be permitted; see 4-8-4/21.25. Cable splices (see 4-8-4/21.23) will be permitted during construction for joining cables between modules, or when extending or truncating the lengths of cables during repair or alteration.

21.1.2 Restricted Locations

Cables are to be located with a view to avoiding, as far as practicable, spaces where excessive heat and flammable gases may be encountered, and also spaces where they may be exposed to mechanical damage. Cables are not to be installed in bilge or tanktop area unless protected from bilge water. Cables are not to be installed in water tanks, oil tanks, cargo tanks, ballast tanks or any liquid tanks except to supply equipment and instrumentations specifically designed for such locations and whose functions require it to be installed in the tank. Where this cannot be avoided, special measures are to be made for effective protection of cables. See also 4-8-4/21.1.9 and 4-8-4/21.15, and 5C-1-7/31.13 for cables used for echo sounder, speed log and impressed current cathodic protection system in hazardous area.

21.1.3 Choice of Insulation

The rated operating temperature of the insulating material is to be at least 10°C higher than the maximum ambient temperature in the space where the cable is installed.

21.1.4 High Voltage Cable

Cables containing high voltage circuits (>1 kV) and cables for circuits of 1 kV or less are not to be installed on the same cable tray, or in the same bunch, duct or box.

21.1.5 Signal Cables

Except for fiber optic cables, non-shielded signal cables for control, monitoring and safety systems essential for propulsion and maneuvering of the vessel which may be affected by electromagnetic interference are not to be run in the same bunch with power or lighting cables.

21.1.6 Paint on Cables

Where paint or any other coating is systematically and intentionally applied on the electric cables, it is to be established that the mechanical and fire performance properties of the cable are not adversely affected.

In this regard:

- i) Fire retardant property is to be confirmed to be in compliance with 4-8-3/9.5.
- ii) It is to be confirmed that the paint and the solvent used will not cause damages to the cable sheath, e.g., cracking.

Overspray on cables or painted exterior cables are not subject to the requirements of this section.

21.1.7 Cable Installation above High Voltage Switchgear and Control-gear

Where a pressure relief flap is provided for high voltage switchgear and high voltage control-gear, the cables are not to be installed near and above this equipment in order to prevent the damage of cables from the flare/flame released from the relief flap upon occurrence of short circuit in this equipment.

21.1.8 Ultraviolet (UV) Light Protection for Wiring Insulation within Fluorescent Light Fixtures

Where the supply cable's outer sheathing or covering is removed once the cable enters a fluorescent light fixture to facilitate routing and/or connection, the insulation on the individual conductors is to be protected against the possible detrimental effects of UV light exposure by one of the following:

- i)* The insulation is to be manufactured with additives that protect the insulation from UV light damage and a test report is to be submitted to ABS.
- ii)* Adequate shielding arrangements are to be provided inside the fixture for the entire length of the exposed insulation within the fixture.
- iii)* UV protective sleeves are to be installed on the full length of the exposed conductors inside the fixture during the installation.

21.1.9 Protection of Cables in Tanks

Where cables are installed in liquid tanks, the following arrangements are to be complied with:

- i)* Cables are to be installed in steel pipes with at least extra-heavy wall thickness with all joints welded and with corrosion-resistant coating.
- ii)* Cable gland with gastight packing is to be provided for the cable at both ends of the cable conduit pipe
- iii)* Cable inside of the vertical cable conduit pipe is to be suitably supported (e.g., by sand-filling or by strapping to a support-wire). Alternatively, the cable inside of the vertical conduit pipe may be accepted without provided support if the mechanical strength of the cable is sufficient to prevent cable damage due to the cable weight within the conduit pipe under continuous mechanical load. Supporting documentation is to be submitted to verify the mechanical strength of the cable with respect to the cable weight inside of the conduit.

21.3 Cable Current Carrying Capacity

Cables sized in accordance with the current carrying capacities of 4-8-3/Table 6, where installed on cable trays, are not to exceed double-banked. Cables sized in accordance with the current carrying capacities of 4-8-3/Table 6 are to be installed in such a manner as to provide sufficient air space around each cable to allow for heat dissipation. See also 4-8-2/7.7.1(c).

21.5 Cable Voltage Drop

Voltage drop at any point of the electrical installation is not to exceed 6% of the nominal voltage. For supplies from batteries with a voltage not exceeding 50 V this figure may be increased to 10%. Where the length of the cable installed is such that, while the conductors are carrying the maximum current under steady state condition of service, this voltage drop limit is exceeded, the cable size is to be increased appropriately to reduce the voltage drop. See also 4-8-2/7.7.1.

21.7 Protection for Electric-magnetic Induction

21.7.1 Multiple Conductor Cables

All phase conductors of alternating-current cables are to be contained within the same sheath in order to avoid overheating due to induction by use of multiple conductor cables.

21.7.2 Single Conductor Cables

As far as possible, twin or multi-conductor cables are to be used in AC power distribution systems. However, where it is necessary to use single-conductor cables in circuits rated more than 20 A, arrangements are to be made to account for the harmful effect of electromagnetic induction as follows:

- i)* The cable is to be supported on non-fragile insulators;
- ii)* The cable armoring (to be non-magnetic, see 4-8-3/9.11) or any metallic protection (non-magnetic) is to be earthed at mid span or supply end only;
- iii)* There are to be no magnetic circuits around individual cables and no magnetic materials between cables installed as a group; and

- iv) As far as practicable, cables for three-phase distribution are to be installed in groups, each group is to comprise cables of the three phases (360 electrical degrees). Cables with runs of 30 m (100 ft) or longer and having cross-sectional area of 185 mm² (365,005 circ. mils) or more are to be transposed throughout the length at intervals of not exceeding 15 m (50 ft) in order to equalize to some degree the impedance of the three phase circuits. Alternatively, such cables are to be installed in trefoil formation.

21.9 Cable Support

21.9.1 General

Cables are to be installed and supported in ways to avoid chafing and undue stress in the cable. Cable supports and associated accessories are to be robust and are to be of materials that are corrosion-resistant or suitably treated to resist corrosion.

21.9.2 Spacing for Cable Support

The distance between cable supports are to be suitably chosen according to the type of cable and the degree of vibration the installation is likely to be subjected to. In general, cables are to be supported and fixed at an interval not to exceed 400 mm (16 in.). For horizontal runs where cables are laid on tray plates, individual support brackets or hanger ladders, the distance between the fixing points may be up to 900 mm (36 in.), provided that there are supports with maximum spacing, as specified above. This relaxation, however, does not apply to cable runs on weather decks where forces from sea water washing over the deck is expected.

Alternatively, cable support systems complying with a recognized standard other than IEC 60092-352 may be used where the installed cables also comply with that standard. Specifically, cable support systems meeting the requirements of IEEE 45 may be used where IEEE 45 cables are installed.

21.9.3 Cable Ties (Including Zip Ties, Cable Ties and Banding)

21.9.3(a) Size. Cable ties are to have a surface area so wide and shaped that the cables are fixed tight without their covering being damaged.

21.9.3(b) Non-metallic materials. Cable ties made from approved materials other than metal (such as polyamide, PVC) may be used, provided that they are flame-retardant in accordance with IEC Publication 60092-101. Where used for cables not laid on top of horizontal cable trays or similar, suitable metal cable ties are to be added at regular intervals not exceeding 2 m (6.5 ft) in order to prevent the release of cables during a fire. This requirement, however, need not apply to one or up to a few small diameter cables connecting to lights, alarm transducers, etc.

The requirements for maximum distance between cable support in 4-8-4/21.9.2 and 4-8-4/21.9.3 are summarized in the following Table:

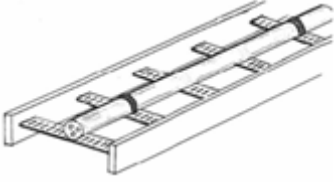
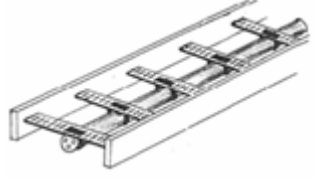
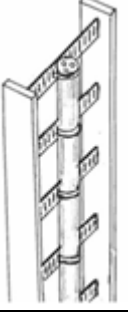
Cable Ties Maximum Installation Distances			
	Orientation		
	Horizontal		Vertical
Function	Fixing Only	Fixing and Support	Fixing and Support
Example Installations	Cable support (400 mm max) provided by cable ladder 		
Metallic Cable Ties	900 mm	400 mm	400 mm
Non-metallic Cable Ties	900 mm	400 mm plus metal at least every 1 m	400 mm plus metal at least every 1 m

21.9.4 Plastic Cable Trays and Protective Casings

21.9.4(a) Installations. Cable trays and protective casings made of plastic materials are to be supplemented by metallic fixing and straps such that, in the event of a fire, they and the cables affixed are prevented from falling and causing an injury to personnel and/or an obstruction to any escape route. See 4-8-4/21.9.3(b). Cable trays and protective casings made of plastic materials are to be flame retardant (see Appendix 4-8-4A1). Where plastic cable trays and protective casings are used on open deck, they are additionally to be protected against UV light by such as anti-UV coating or equivalent.

Note: “Plastic” means both thermoplastic and thermosetting plastic materials with or without reinforcement, such as PVC and fiber reinforced plastics – FRP. “Protective casing” means a closed cover in the form of a pipe or other closed ducts of non-circular shape.

21.9.4(b) Safe Working Load. The load on the cable trays and protective casings is to be within the Safe Working Load (SWL). The support spacing is to be not greater than the manufacturer’s recommendation nor in excess of the spacing at the SWL test (see Appendix 4-8-4A1). In general, the spacing is not to exceed 2 meters.

Note: The selection and spacing of cable tray and protective casing supports are to take into account:

- Dimensions of the cable trays and the protective casings;
- Mechanical and physical properties of their material;
- Mass of the cable trays/protective casings;
- Loads due to weight of cables, external forces, thrust forces and vibrations;
- Maximum accelerations to which the system may be subjected;
- Combination of loads.

21.9.4(c) Cable occupation ratio in protective casing. The sum of the total cross-sectional area of all cables on the basis of their external diameter is not to exceed 40% of the internal cross-sectional area of the protective casing. This does not apply to a single cable in a protective casing.

21.9.4(d) Hazardous areas. Cable trays and protective casings passing through hazardous areas are to be electrically conductive (see Appendix 4-8-4A1).

21.9.4(e) Type Testing. Cable trays and protective casings made of plastic materials are to be type-tested in accordance with Appendix 4-8-4A1. Alternate test procedures for impact resistance test, safe working load test, flame retardant test, smoke and toxicity tests and/or resistivity test from an international or national standard may be considered instead of the test specified in Appendix 4-8-4A1. The type test reports are to be submitted for review.

21.11 Cable Bending Radii

Cable bending radii may adhere to manufacturer’s recommendations or the cable construction standard. Notwithstanding that, the bending radii are to be in accordance with the following table:

Cable Construction		Overall Diameter, D	Minimum Internal Bending Radius
Insulation	Outer Covering		
Thermoplastic or thermosetting with circular copper conductor	Unarmored or unbraided	$D \leq 25$ mm (1 in.)	$4 D$
		$D > 25$ mm	$6 D$
	Metal braid screened or armored	Any	$6 D$
	Metal wire or metal-tape armored or metal-sheathed	Any	$6 D$
	Composite polyester/metal laminate tape screened units or collective tape screening	Any	$8 D$
Thermoplastic or thermosetting with shaped copper conductor	Any	Any	$8 D$
Mineral	Hard metal-sheathed	Any	$6 D$

21.13 Deck and Bulkhead Penetrations

21.13.1 General

Where cables pass through watertight or fire-rated bulkheads or decks, the penetrations are to be made through the use of approved stuffing tubes, transit devices or pourable materials installed in accordance with manufacturer's installation procedures to maintain the watertight integrity or fire-rating of the bulkheads or decks. These devices or materials are not to cause damage to the cable and are to be examined and tested as specified in 3-7-1/Table 1 and 4-8-4/29.15.

Where cable conduit pipe or equivalent is carried through decks or bulkheads, arrangements are to be made to maintain the integrity of the water or gas tightness of the structure

21.13.2 Structural Insulation

Cables are not to be installed behind, or imbedded in, structural insulation. They may, however, pass through such insulation at approximately right angle. The penetration design is to preserve the insulation rating. Cable conduit or recess integral with B or C class fire-walls may be used for installing cables for accommodation purposes, subject to the following conditions:

- i) Such fire-walls are of an approved type (e.g., by an Administration for meeting SOLAS), and
- ii) Arrangements are made to prevent the propagation of smoke through the conduit.

21.13.3 Non-watertight Penetrations

When cables pass through non-watertight bulkheads, decks or structural members, the length of the bearing surface for the cable is to be at least 6.4 mm (0.25 in.). All burrs and sharp edges are to be removed in way of the penetration.

21.13.4 Collision Bulkhead

No cable is allowed to penetrate the collision bulkhead.

21.13.5 Refrigerated Spaces

For penetration through insulated, refrigerated space bulkheads, cables are to be installed in phenolic pipes or similar heat-insulating material. The pipe may be inserted through the bulkhead stuffing tube or joined directly to the bulkhead penetration piece.

21.15 Mechanical Protection for Cables

21.15.1 General

Electrical cables exposed to risk of mechanical damage during normal operation of the vessel are to be of the type provided with metallic armor or otherwise suitably protected from mechanical injury.

21.15.2 Additional Protection

Cables installed in locations such as within cargo holds, in way of cargo hatch openings, open decks subjected to seas, etc., even of the armored type, are to be protected by substantial metal shields, structural shapes, pipe or other equivalent means, which are to be of sufficient strength to provide effective protection to the cables. Metallic protections are to be electrically continuous and earthed to the hull. Non-metallic protections are to be flame retardant. Expansion bellows or similar, where fitted, are to be accessible for maintenance.

21.15.3 Drainage

Cable protective casings, pipes and similar fixtures are to be provided with drainage.

21.17 Installation of Cables and Apparatus for Emergency and Essential Services

21.17.1 Emergency and Essential Feeders

As far as practicable, cables and wiring for emergency and essential services, including those listed in 4-8-4/1.9, are not to pass through high fire risk areas (see 4-8-4/1.11). For Emergency Fire Pumps, see requirements in 4-8-4/21.17.3.

These cables and wiring are also to be run in such a manner as to preclude their being rendered unserviceable by heating of the bulkheads that may be caused by a fire in an adjacent space.

21.17.2 Services Necessary Under a Fire Condition

Where cables for services required to be operable under a fire condition (see 4-8-4/1.9) including their power supplies pass through high fire risk areas (see 4-8-4/1.11) other than those which they serve, they are to be so arranged that a fire in any of these areas does not affect the operation of the service in any other area. For Emergency Fire Pumps, see requirements in 4-8-4/21.17.3. For passenger vessels, see 5C-7-5/13.7.2(a). This may be achieved by either of the following measures:

21.17.2(a) Fire resistant cables in accordance with 4-8-3/9.7 are installed and run continuous to keep the fire integrity within the high fire risk area. See 4-8-4/Figure 1.

FIGURE 1
Cables within High Fire Risk Areas

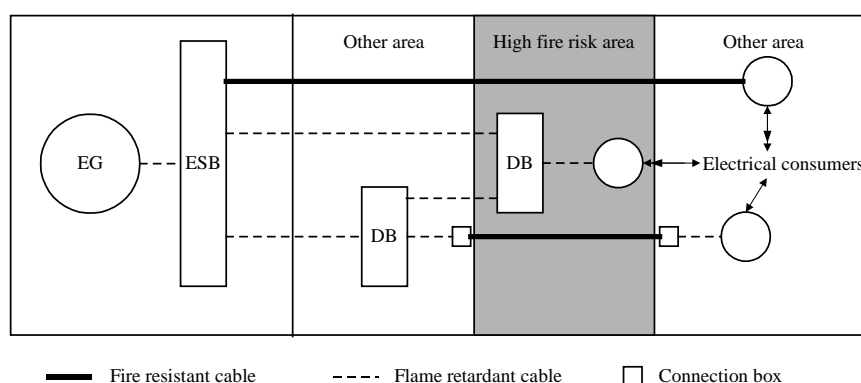

21.17.2(b) At least two routes/radial distributions run as widely apart as is practicable and so arranged that in the event of damage by fire at least one of the loops/radial distributions remains operational.

Systems that are self-monitoring, fail safe or duplicated with cable runs separated as widely as practicable, may be exempted from the requirements in 4-8-4/21.17.2(a) and 4-8-4/21.17.2(b).

21.17.3 Electrical Cables for the Emergency Fire Pump

The electrical cables to the emergency fire pump are not to pass through the machinery spaces containing the main fire pumps and their sources of power and prime movers. They are to be of a fire resistant type, in accordance with 4-8-3/9.7, where they pass through other high fire risk areas.

21.17.4 Requirements by the Governmental Authority

Attention is directed to the requirements of the governmental authority of the country whose flag the vessel flies for the installation of emergency circuits required in various types of vessels.

21.19 Mineral Insulated Cables

At all points where a mineral-insulated, metal-sheathed cable terminates, an approved seal is to be provided immediately after stripping to prevent entrance of moisture into the mineral insulation and, in addition, the conductors extending beyond the sheath are to be insulated with an approved insulating material. When a mineral-insulated cable is connected to boxes or equipment, the fittings are to be approved for the conditions of service. The connections are to be in accordance with the manufacturer's installation recommendation.

21.21 Fiber Optic Cables

The installation of fiber optic cables is to be in accordance with the manufacturer's recommendations to prevent sharp bends where the fiber optic cables enter the equipment enclosure. Consideration is to be given to the use of angled stuffing tubes. The cables are to be installed so as to avoid abrading, crushing, twisting, kinking or pulling around sharp edges.

21.23 Installation of Cable Splices

All splices are to be made with an approved splice kit, see 4-8-3/9.19. No splice is permitted in hazardous areas, except for cables of intrinsically safe circuits. Neither is splice permitted in propulsion cables. Where permitted, the following installation details are to be complied with:

- i) All splices are to be made after the cables are in place and are to be in locations accessible for inspection.
- ii) The conductor splice is to be made using a pressure type butt connector by means of a one-cycle compression tool.
- iii) Armored cables having splices are not required to have the armor replaced, provided that the armor is made electrically continuous.
- iv) Splices are to be so arranged that mechanical stresses are not carried by the splice.

Splicing of fiber optic cables is to be by means of mechanical or fusion methods, as recommended by the manufacturer.

21.25 Installation of Cable Junction Boxes

Junction boxes may be employed to connect cables, provided they are of approved design, see 4-8-3/9.21. Junction boxes are not to be used in propulsion cables, however. Where permitted, the following installation details are to be complied with:

- i) The junction box enclosures are to be suitable for the locations of installation.
- ii) Junction boxes are to be in locations accessible for inspection.
- iii) For low voltage systems (50 V, 110 V, etc. up to 1 kV AC, see 4-8-1/7.3.1), each voltage level is to be provided with its own junction box or separated by physical barriers within the same junction box. For high voltage systems (> 1 kV), a separate junction box is to be used for each of the voltage levels.
- iv) Emergency circuits and normal circuits are not to share the same junction box.
- v) Armored cables are to have their armoring made electrically continuous.
- vi) Cables arranged for connection at a junction box are to be well-supported and fastened so that conductor contacts are not subjected to undue stress.

21.27 Cable Termination

Cables stripped of moisture-resistant insulation are to be sealed against the admission of moisture by methods such as taping in combination with insulating compound or sealing devices. Cable conductors for connection to terminals are to be fitted with crimp lugs of corresponding current rating, or equivalent. Soldered lugs are permitted for conductors up to 2.5 mm² only. Cables are to be secured to the terminal box or other sturdy structure in such a manner that stresses are not transmitted to the terminal. Cable's moisture resistant jacket is to extend through the outermost cable clamp of the terminal box. Where applicable, other properties of the cable, e.g., flame retarding, fire resistant, etc. are to be retained through to the terminal box.

23 Equipment Earthing

23.1 General Requirements

23.1.1 Equipment

For protection against electrical shock, exposed metal parts of electrical machine or equipment which are not intended to be live but which are liable under fault conditions to become live are to be earthed unless the machine or equipment is:

- i)* Supplied at a voltage not exceeding 50 V (DC or AC rms) between conductors (auto-transformers are not to be used for the purpose of achieving this voltage); or
- ii)* Supplied at a voltage not exceeding 250 V (AC) by safety isolating transformers supplying only one consuming device; or
- iii)* Constructed in accordance with the principle of double insulation.

23.1.2 Cables

Metallic armor of cables and metallic sheath of mineral-insulated, metal-sheathed cables are to be electrically continuous and are to be earthed to the metal hull at each end of the run, except that final sub-circuits may be earthed at the supply end only. All metallic coverings of power and lighting cables passing through hazardous areas or connected to equipment in such an area are to be earthed at least at each end.

23.1.3 Receptacles

Receptacles operating at more than 50 V are to have an earthing pole. Attachment plugs for non-permanently fitted equipment operating at more than 50 V are to have an earthing pole and an earthing conductor in the portable cord to earth the dead metal parts of the equipment.

23.3 Earthing Methods

The metal frames or enclosure of permanently installed electrical equipment may be earthed through metallic contact with the vessel's structure where the arrangement and method of installation assure positive earthing. Otherwise, they are to be connected to the hull by a separate conductor, as follows:

- i)* Earthing conductor is to be of copper or other corrosion resistant material.
- ii)* The nominal cross-sectional area of every copper earthing conductor is to be not less than that required by 4-8-4/Table 1.
- iii)* Connection of an earthing conductor to the hull is to be made in an accessible location, protected from mechanical damage, and secured by a screw of corrosion-resistant material having a cross-sectional area equivalent to the required earthing conductor but, in any case, not less than 4 mm (0.16 in.) in diameter.

23.5 Lightning Earth Conductors

Each wooden mast or topmast is to be fitted with lightning earth conductors. They need not be fitted to steel masts.

25 System Earthing

System earthing is to be in accordance with 4-8-2/7.5 for low voltage system, and with 4-8-5/3.3.1 for high voltage system. Earthing method, as described in 4-8-4/23.3, is to be complied with.

TABLE 1
Size of Earthing Conductors (Equipment and System Earthing)

Type of Earthing Connection		Cross-sectional Area, A, of Associated Current Carrying Conductor	Minimum Cross-sectional Area of Copper Earthing Connection
Earth-continuity conductor in flexible cable or flexible cord	A1	$A \leq 16 \text{ mm}^2$	A
	A2	$16 \text{ mm}^2 < A \leq 32 \text{ mm}^2$	16 mm ²
	A3	$A > 32 \text{ mm}^2$	$A/2$
Earth-continuity conductor incorporated in fixed cable	For cables having an insulated earth-continuity conductor		
	B1a	$A \leq 1.5 \text{ mm}^2$	1.5 mm ²
	B1b	$1.5 \text{ mm}^2 < A \leq 16 \text{ mm}^2$	A
	B1c	$16 \text{ mm}^2 < A \leq 32 \text{ mm}^2$	16 mm ²
	B1d	$A > 32 \text{ mm}^2$	$A/2$
	For cables with bare earth wire in direct contact with the lead sheath		
	B2a	$A \leq 2.5 \text{ mm}^2$	1 mm ²
	B2b	$2.5 \text{ mm}^2 < A \leq 6 \text{ mm}^2$	1.5 mm ²
Separate fixed earthing conductor	C1a	$A \leq 3 \text{ mm}^2$	Stranded earthing connection: 1.5 mm ² for $A \leq 1.5 \text{ mm}^2$ A for $A > 1.5 \text{ mm}^2$
	C1b		Unstranded earthing connection: 3 mm ²
	C2	$3 \text{ mm}^2 < A \leq 6 \text{ mm}^2$	3 mm ²
	C3	$6 \text{ mm}^2 < A \leq 125 \text{ mm}^2$	$A/2$
	C4	$A > 125 \text{ mm}^2$	64 mm ² , see Note 1

Note:

- 1 For earthed distribution systems, the size of earthing conductor is not to be less than $A/2$.

27 Electrical Equipment in Hazardous Areas

27.1 General

Hazardous areas are spaces where flammable or explosive gases, vapors or dust are normally present, or likely to be present. Hazardous areas are to be classified based on the likelihood of presence and the concentration and type of flammable atmosphere, as well as in terms of the extent of the space. Electrical equipment is not to be installed in hazardous areas unless it is essential for safety or for operational purposes. Where the installation of electrical equipment in such location is necessary, it is to be selected based on its suitability for the hazardous area so classified. Such equipment is to be as specified in the appropriate sections of the Rules, as indicated below.

Generally electrical equipment certified for use in hazardous areas in accordance with the IEC 60079 series is considered suitable for use in temperatures from -20°C to 40°C (-4°F to 104°F). Account is to be taken of the temperature at the point of installation when selecting electrical equipment for installation in hazardous areas.

Fans used for the ventilation of the hazardous areas are to be of non-sparking construction in accordance with 4-8-3/11.

27.3 Hazardous Areas

27.3.1 General

The following spaces are, in general, to be regarded as hazardous areas:

- i) Tanks containing flammable liquids having a flash point of 60°C (140°F) or below.
- ii) Holds containing solid bulk cargoes liable to release flammable gases or dust.
- iii) Holds or enclosed cargo spaces containing cargoes that are likely to emit flammable gases or vapors (e.g., dangerous goods, vehicles with fuel in their tanks, etc.)
- iv) An enclosed or semi-enclosed space:
 - Having a direct access or opening into the hazardous areas defined in i), ii) or iii), through a door, a ventilation opening, etc.;
 - Immediately adjacent to the hazardous areas defined in i); or
 - Containing pumps or piping used for conveying liquid described in i).
- v) A defined zone in open space:
 - 3 m (10 ft) from an opening to the hazardous areas defined in i), ii), iii) or iv), such as a door, a ventilation opening, a tank vent, etc., unless as otherwise indicated in 4-8-4/27.3.2 and 4-8-4/27.3.3;
 - Immediately adjacent to the hazardous area defined in i); or
 - In way of pumps or piping used for conveying liquid described in i).

27.3.2 Specific Vessel Types

Due to the nature of the cargoes carried, or the types of operation performed at sea, hazardous areas are defined for the following vessel types in the appropriate sections of the Rules:

- i) Oil carriers carrying crude oil or refined oil products having a flash point of 60°C (140°F) or below. See 5C-1-7/31.
- ii) Bulk carriers carrying coal or other dangerous cargoes in bulk. See 5C-3-7/3.
- iii) Container carriers or dry cargo vessels carrying dangerous goods or vehicles with fuel in their tanks. See 5C-5-7/3.
- iv) Roll-on/roll-off vessels carrying vehicles with fuel in their tanks. See 5C-10-4/3 and 5C-10-4/5.
- v) Liquefied gas carriers carrying flammable gases. See 5C-8-1/2.24.
- vi) Chemical carriers carrying flammable liquid having a flash point of 60°C or below. See 5C-9-10/1.4.
- vii) Drilling vessels performing exploratory or production drilling of hydrocarbon deposits. See 4-3-6/3 of the *ABS Mobile Offshore Unit Rules*.
- viii) Floating hydrocarbon production facilities. See the *ABS Rules for Building and Classing Floating Production Installations*.

27.3.3 Miscellaneous Spaces

The following spaces are to be regarded as hazardous areas:

27.3.3(a) *Paint stores*. Within the paint store; open deck area within 1 m (3 ft) from ventilation inlet and natural ventilation outlet; and open deck area within 3 m (10 ft) from power ventilation outlet. Enclosed spaces giving access to the paint store may be considered as non-hazardous, provided that:

- i) The door to the paint store is gastight with self-closing devices without holding back arrangements,
- ii) The paint store is provided with an acceptable, independent, natural ventilation system ventilated from a safe area, and
- iii) Warning notices are fitted adjacent to the paint store entrance stating that the store contains flammable liquids.

27.3.3(b) *Battery rooms.* Within the battery room; open deck area within 1 m (3 ft) from natural ventilation outlet, and open area within 3 m (10 ft) from power ventilation outlet. See 4-8-4/5.3.1.

27.3.3(c) *Helicopter refueling facilities.* Enclosed space containing components of the refueling pump/equipment; and open deck area within 3 m (10 ft) from ventilation outlet of enclosed space containing refueling pump/equipment, 3 m (10 ft) from tank vent outlet, and 3 m (10 ft) from refueling pump/equipment.

27.3.3(d) *Oxygen-acetylene storage rooms.* Within the storage room; open deck area within 1 m (3 ft) from natural ventilation outlet, and open area within 3 m (10 ft) from power ventilation outlet. See 4-6-7/7.3. The area within 3 m (10 ft) of the gas cylinders pressure relief device discharge outlet. See 4-6-7/7.5.4.

27.5 Certified Safe Equipment in Hazardous Areas

27.5.1 General

Only electrical equipment of the following types complying with IEC Publication 60079 series, or other recognized standards, as described in 4-8-3/13, is to be considered for installation in hazardous areas.

- Intrinsically safe type (Ex i)
- Flameproof (explosion-proof) type (Ex d)
- Increased safety type (Ex e)
- Pressurized or purged type (Ex p)

Consideration is to be given to the flammability group and the temperature class of the equipment for suitability for the intended hazardous area, see IEC Publication 60079-20.

27.5.2 Paint Stores

Electrical equipment installed in paint stores may be any of the types indicated in 4-8-4/27.5.1 and is to be at least IEC Publication 60079-20-1 group IIB class T3. In defined hazardous areas on open deck outside paint stores, electrical equipment with IP 55 enclosure or better, whose surfaces do not reach unacceptable high temperature, may also be accepted.

27.5.3 Battery Room

Electrical equipment installed in battery room may be any of the types indicated in 4-8-4/27.5.1 and is to be IEC Publication 60079-20-1 group IIC class T1.

27.5.4 Oxygen-acetylene Storage Room

Electrical equipment installed in oxygen-acetylene storage room may be any of the types indicated in 4-8-4/27.5.1 and is to be IEC Publication 60079-20-1 group IIC class T2.

In explosive gas atmospheres containing acetylene, equipment protection by flameproof (explosion proof) enclosures “Ex d” for external mounting, where constructed of copper or copper alloys is to be:

- i) Coated with tin, nickel, or other coating; or
- ii) Alternatively the maximum copper content of the alloy is to be limited to 60%.

Flameproof entry devices are not considered an enclosure surface requiring coating or copper content restriction.

27.5.5 Helicopter Refueling Facilities

Electrical equipment installed in areas defined for helicopter refueling facilities may be any of the types in 4-8-4/27.5.1 and is to be at least IEC Publication 60079-20-1 group IIA class T3.

27.5.6 Other Spaces

Electrical equipment allowable in hazardous areas defined in 4-8-4/27.3.2 is given in appropriate sections in Part 5C of these Rules, the *ABS Rules for Mobile Offshore Units* and the *ABS Rules for Building and Classing Floating Production Installations*.

27.7 Intrinsically Safe Systems

27.7.1 Installation of Cables and Wiring

27.7.1(a) General. Installations with intrinsically safe circuits are to be erected in such a way that their intrinsic safety is not adversely affected by external electric or magnetic fields under normal operating condition and any fault conditions, such as a single-phase short circuit or earth fault in non-intrinsically safe circuits, etc.

27.7.1(b) Separation and Mechanical protection. The installation of the cables is to be arranged as follows:

- i) Cables in both hazardous and non-hazardous areas are to meet one of the following requirements:
 - Intrinsically safe circuit cables are to be installed a minimum of 50 mm (2 in.) from all non-intrinsically safe circuit cables, or
 - Intrinsically safe circuit cables are to be so placed as to protect against the risk of mechanical damage by use of mechanical barrier, or
 - Intrinsically safe or non-intrinsically safe circuit cables are to be armored, metal sheathed or screened.
- ii) Conductors of intrinsically safe circuits and non-intrinsically safe circuits are not to be carried in the same cable.
- iii) Cables of intrinsically safe circuits and non-intrinsically safe circuits are not to be in the same bundle, duct or conduit pipe.
- iv) Each unused core in a multi-core cable is to be adequately insulated from earth and from each other at both ends by the use of suitable terminations.

27.7.2 Arrangements of Common Enclosure

27.7.2(a) Sub-compartment. When intrinsically safe components are located by necessity within enclosures that contain non-intrinsically safe systems, such as control consoles and motor starters, such components are to be effectively isolated in a sub-compartment by earthed metallic or nonmetallic insulating barriers having a cover or panel secured by bolts, locks, Allen-screws, or other approved methods. The intrinsic safety in the sub-compartment is not to be adversely affected by external electric or magnetic fields under normal operating condition and any fault conditions in non-intrinsically safe circuits.

27.7.2(b) Termination Arrangements. Where it is impracticable to arrange the terminals of intrinsically safe circuit in the sub-compartment, they are to be separated from those for non-intrinsically safe circuits by either of the following methods. Other National or International recognized Standards will also be accepted.

- i) When separation is accomplished by distance, then the clearance between terminals is to be at least 50 mm, or
- ii) When separation is accomplished by use of an insulating partition or earthed metal partition, the partitions are to extend to within 1.5 mm of the walls of the enclosure, or alternatively provide a minimum measurement of 50 mm between the terminals when taken in any direction around the partition.

27.7.2(c) *Identification plate.* The terminals and sub-compartment for intrinsically safe circuit and components are to have a nameplate indicating that the equipment within is intrinsically safe and that unauthorized modification or repairs are prohibited.

27.9 Cables in Hazardous Areas

Cables in hazardous areas are to be armored or mineral-insulated metal-sheathed, except for cables of intrinsically safe circuits subject to the requirements of 4-8-4/21.15. Where cables pass through boundaries of such locations, they are to be run through gastight fittings. No splices are allowed in hazardous areas, except in intrinsically safe circuits.

27.11 Lighting Circuits in Hazardous Areas

All switches and protective devices for lighting fixtures in hazardous areas are to interrupt all poles or phases and are to be located in a non-hazardous area. However, a switch may be located in a hazardous area if the switch is of a certified safe type for the hazardous location in which it is to be installed. On solidly grounded distribution systems, the switches need not open the grounded conductor. The switches and protective devices for lighting fixtures are to be suitably labeled for identification purposes.

27.13 Permanent Notice and Booklet of Certified Safe Equipment

A booklet containing the list of certified safe equipment, as installed, along with the particulars of the equipment (see 4-8-1/5.3.2), is to be maintained onboard. Permanent notices are to be posted in the vicinity of hazardous areas in which such electrical equipment is installed to advise crew of the availability of the booklet so that it can be referenced during repair or maintenance.

29 Shipboard Tests

29.1 General

Upon completion of the installation, electrical systems are to be tested under working conditions to the satisfaction of the Surveyor.

29.3 Generators

Each generator is to be operated for a time sufficient to show satisfactory operation, individually and in parallel, and with all possible load combinations.

29.5 Switchboards

Generator protective devices, e.g., overload protection, reverse power protection, undervoltage protection, preferential trip and auxiliary motor sequential starting, as applicable, are to be tested.

29.7 Motors

Each motor is to be operated for a time sufficient to show satisfactory performance at such load as can readily be obtained.

29.9 Interior Communications System

Satisfactory operation of the interior communications system, as required by 4-8-2/11.5, is to be demonstrated. Particular attention is to be paid to the voice communication system for its audibility while the vessel is under way.

29.11 Voltage Drop Measurement

Voltage drop along power and lighting cables is to be measured. Voltage drop at any part of the installation is not to exceed the limits specified in 4-8-2/7.7.1(d).

29.13 Insulation Resistance Measurements

Insulation resistance of power and lighting cables is to be measured. Appliances connected to the circuits may be disconnected for this test. Each power and each lighting circuit is to have an insulation resistance between conductors and between each conductor and earth of not less than the following values.

<i>Load (A)</i>	<i>Insulation Resistance (MΩ)</i>
≤ 5	2
≤ 10	1
≤ 25	0.4
≤ 50	0.25
≤ 100	0.10
≤ 200	0.05
> 200	0.025

29.15 Watertight and Fire-rated Deck and Bulkhead Cable Penetrations

During installation of deck and bulkhead watertight and fire-rated cable penetrations, the attending Surveyor is to confirm that the installer is familiar with and has access to the manufacturer's installation procedures for stuffing tubes, transit devices or pourable materials.

After installation, all watertight and fire-rated cable penetrations are to be visually examined. Watertight cable penetrations are to be tested as required by 3-7-1/Table 1.

31 Guidance for Spare Parts

While spare parts are not required for class, the spare parts listed below are for unrestricted service and are provided as a guidance to assist in ordering spare parts which may be appropriate for the intended service. The maintenance of spare parts aboard each vessel is the responsibility of the owner.

31.1 Spare Parts of Electrical Equipment

One complete set of bearings for each size and type of generator and motor.

31.3 Measuring Instrument

A 500 V insulation-resistance measuring instrument (megger).

4

CHAPTER 8 Electrical Systems

SECTION 4 Appendix 1 –Type Test Procedure for Plastic Cable Tray and Protective Casing

1 General

Cable trays and protective casings made of plastic materials are to be type-tested in accordance with Appendix 4-8-4A1, as per 4-8-4/21.9.4. Alternate test procedures for impact resistance test, safe working load test, flame retardant test, smoke and toxicity tests and/or resistivity test from an international or national standard may be considered instead of the test specified in Appendix 4-8-4A1.

3 General Design Requirements

3.1 Ambient Temperatures

Cable trays and protective casings are to be designed for the following ambient temperatures:

–25°C to 90°C for outdoor use

+5°C to 90°C for indoor use.

Note: Consideration will be given to the use of plastic cable trays and protective casings in cold environments where the ambient temperature is below –25°C, provided the mechanical properties of the plastics required for the intended purpose and location of installation can be maintained at such temperatures. In this particular instance, the cold bend and cold impact properties of the material are also to be considered.

3.3 Test Temperature

3.3.1 Impact Test

Impact tests are to be carried out at the lowest (coolest) of the following temperatures:

- i) Lowest (coolest) range of the outdoor ambient, where applicable,
- ii) Lowest (coolest) range of the indoor ambient, where applicable, or
- iii) Any other temperature the manufacturer may wish to specify.

3.3.2 Safe Working Load (SWL) Test

At the option of the manufacturer, the SWL tests may be carried out in any of the following conditions:

- i) At any temperature within the declared range if documentation is available which states that the relevant structural properties of the materials as used within the system do not differ by more than 5% of the average between the maximum and minimum property values,
- ii) Only at the maximum temperature within the range if documentation is available which states that the relevant structural properties of the materials, as used within the system, decrease when the temperature is increasing, or
- iii) At the maximum and minimum temperature only.

In all instances, the tests are to be carried out for the smallest and largest sizes of cable tray lengths or cable ladder lengths, having the same material, joint and topological shape.

3.5 Safe Working Load

Cable tray and protective casings are to be assigned a Safe Working Load, in accordance with 4-8-4A1/5.3.

5 Mechanical Requirements

5.1 Impact Resistance Test

The test is to be performed in accordance with IEC 60068-2-75 using the pendulum hammer.

- i) The test is to be carried out on test samples of cable tray lengths or cable ladder lengths of 250 mm ± 5 mm long. Test samples of ladder are to consist of two side-members with one rung positioned centrally. Test sample of mesh trays is to be prepared in such a way that there will be a wire in the center.
- ii) Before the test, plastic components are to be aged at a temperature of 90°C ± 2°C for 240 hours continuously.
- iii) The test sample is to be mounted on wooden fiberboard of thickness 20 mm ± 2 mm.
- iv) The test sample to be tested is to be placed in a refrigerator, the temperature within which is maintained at the test temperature in accordance with 4-8-4A1/3.3.1 above with a tolerance of ±2°C.
- v) After 2 h, the test sample is to be removed from the refrigerator and immediately placed in the test apparatus.
- vi) At 10 s ± 1 s after removal of each test sample from the refrigerator, the hammer is to be allowed to fall with impact energy, the mass of the hammer and the fall height:

<i>Approximate Energy (J)</i>	<i>Mass of Hammer (kg)</i>	<i>Fall Height (mm)</i>
10	5.0	200 ± 2

- vii) The impact is to be applied to the base or the rung in the first test sample, to one of the side members in the second test sample, and to the other side member in the third test sample. In each case, the impact is to be applied to the center of the face being tested.
- viii) After the test, the test sample is to show no signs of disintegration and/or deformation that will impair safety.

5.3 Safe Working Load (SWL) Test

- i) Cable trays and protective casings and joints are to be assigned a Safe Working Load (SWL) satisfying the following criteria and to be tested at the test temperatures according to 4-8-4A1/3.1 and 4-8-4A1/3.3.2 above:
 - The maximum deflection under SWL is not to exceed $L/100$, where L is the distance between the supports, and
 - No mechanical defects or failures are observed when tested to $1.7 \times \text{SWL}$.
- ii) All loads are to be uniformly distributed over the length and width of the test samples, as shown in 4-8-4A1/Figure 1.

The loads are to be applied in such a way that a uniform distribution is ensured even in the case of extreme deformation of the test samples.

To allow for settlement of the test samples, a pre-load of 10% of SWL, unless otherwise specified, is to be applied and held for at least five (5) min, after which the measurement apparatus is to be calibrated to zero.
- iii) Then, the load is to be gradually increased evenly, longitudinally and transversely up to the SWL continuously. When a continuous increase is impractical, the load may be increased by increments. These increments are not to exceed about a quarter of the SWL. The load increments are to be distributed through the load plates longitudinally and transversely as evenly as is practical.

- iv) After loading, the deflection is to be measured at the points specified to give a practical mid-span deflection.
- v) The test sample with load is to be left and the deflections measured every five (5) minutes until the difference between two consecutive sets of readings becomes less than 2% of the first set of the two readings. The maximum deflection for the purpose of 4-8-4A1/5.3i) is the first set of the readings measured at this point under the test load.
- vi) When subject to SWL, the test sample, their joints and internal fixing devices are to show no damage or crack visible to normal view or corrected vision without magnification.
- vii) Then, the load is to be increased to 1.7 times SWL.

The test sample with the load are to be left and the deflections measured every five (5) min until the difference between two consecutive sets of readings becomes less than 2% of the first set of the two readings. The test sample is to sustain the increased loading without collapsing. However, buckling and deformation of the test sample are allowable at this excess loading.

FIGURE 1
SWL Loading Test Procedure

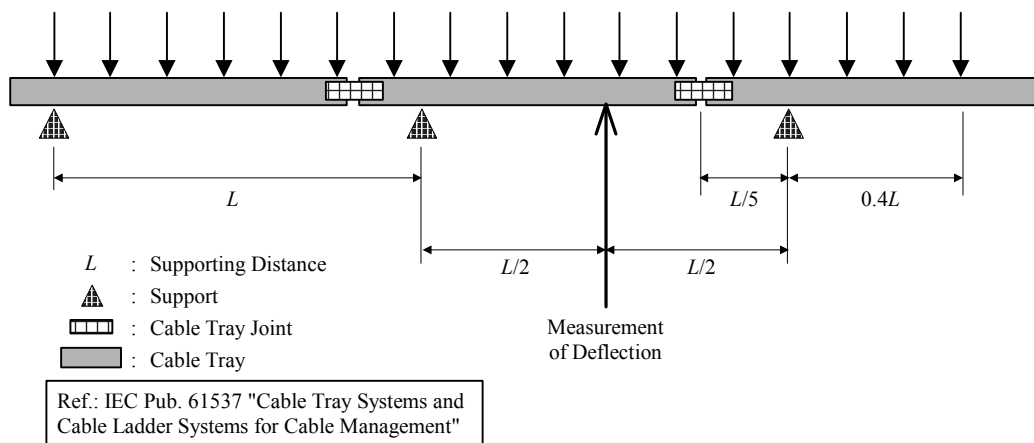

7 Fire Properties

7.1 Flame Retardant Test

The cable trays and protective casings are to be at least flame retardant. They are to be tested in accordance with the following Table.

Procedure According To	Test Parameters	Other Information
IEC Publication 60092-101, or IEC Publication 60695-11-5	– Flame application: 5 times 15 sec each. – Interval between each application: 15 sec., or 1 time 30 sec. Test criteria based upon application.	– The burnt out or damaged part of the test sample by not more than 60 mm long. – Equipment design and the choice of materials are to reduce the likelihood of fire, ensuring that the surfaces of the test sample do not contribute to the fire growth where they are exposed to the flame.

7.3 Smoke and Toxicity Test

The cable tray and protective casings are to be tested in accordance with the IMO Fire Test Procedures Code (FTPC), Resolution MSC.61(67), Part 2 — Smoke and Toxicity Test, or any international or national standard.

9 Electrical Properties

9.1 Resistivity Test

Cable trays and protective casings passing through a hazardous area are to be electrically conductive.

The volume resistivity level of the cable trays and protective casings and fittings are to be below 100 kΩm ($1 \times 10^5 \Omega\text{m}$) and the surface resistivity is to be below 100 MΩ ($1 \times 10^8 \Omega$). The cable tray and protective casings are to be tested in accordance with IEC 60093.

Note The resistance to earth from any point in these appliances is not to exceed 1 MΩ ($1 \times 10^6 \Omega$).

4

CHAPTER 8 Electrical Systems

SECTION 5 Special Systems

1 Application

The provisions of this Section apply to (a) high voltage systems; (b) electric propulsion systems; and (c) three-wire dual-voltage DC systems; and (d) electric plants of less than 75 kW. Unless stated otherwise, the applicable requirements of Section 4-8-1 through Section 4-8-4 are also to be complied with.

3 High Voltage Systems

3.1 Application

The requirements in this subsection are applicable to AC systems with nominal voltage (phase to phase) exceeding 1 kV. Unless stated otherwise, the applicable requirements of Section 4-8-1, Section 4-8-2, Section 4-8-3 and Section 4-8-4 are also to be complied with.

The nominal standard voltage is not to exceed 15 kV. A higher voltage may be considered for special application.

3.3 System Design

3.3.1 Earthed Neutral Systems

3.3.1(a) Neutral Earthing. The current in the earth fault condition is to be not in excess of full load current of the largest generator on the switchboard or relevant switchboard section and in no case less than three times the minimum current required for operation of any device in the earth fault condition.

An earth connection is to be available when any part of the system is in the energized mode.

3.3.1(b) Equipment. Electrical equipment in directly earthed neutral or other neutral earthed systems is to be able to withstand the current due to a single phase fault against earth for a period necessary to trip the protection device.

3.3.1(c) Neutral Disconnection. Each generator neutral is to be provided with means for disconnection for maintenance purposes.

3.3.1(d) Hull Connection of Earthing Impedance. All earthing impedances are to be connected to the hull. The connection to the hull is to be so arranged that any circulating currents in the earth connections will not interfere with radio, radar, communication and control equipment circuits. In systems with neutral earthed, connection of the neutral to the hull is to be provided for each generator switchboard section.

3.3.2 Earth Fault Detection and Indication

- i)* In unearthed or high impedance earthed systems an earth fault is to be indicated by visual and audible means at the centralized control station.
- ii)* In low impedance or direct earthed systems, provision is to be made to automatically disconnect the faulty circuits. Audible and visual indication is to be provided at the centralized control station to indicate that a ground fault had occurred and has been cleared by ground fault protection. An audible alarm is to be provided if the ground fault was not successfully cleared.

- iii) In high impedance earthed systems where outgoing feeders will not be isolated in case of an earth fault, the insulation of the equipment is to be designed for the phase to phase voltage.

3.3.3 Number and Capacity of Transformers

Requirements for the number and capacity of transformers are given in 4-8-2/3.7.1.

For transformers with a high voltage winding over 1000 V, the following would not be accepted as complying with the above requirement:

- i) The provision of a spare single phase transformer to substitute a failed transformer.
- ii) The operation of two single phase transformers in an open delta (V-V) connection.

3.5 Circuit Protection

3.5.1 Protection of Generator

Protection against phase-to-phase fault in the cables connecting the generators to the switchboard and against inter-winding faults within the generator is to be provided. This is to trip the generator circuit breaker and automatically de-excite the generator. In distribution systems with a low impedance earthed neutral, phase to earth faults are to be likewise treated.

3.5.2 Protection of Power Transformers

Power transformers are to be provided with overload and short-circuit protection. Each high-voltage transformer intended to supply power to the low-voltage ship service switchboard is to be protected in accordance with 4-8-2/9.19. In addition, the following means for protecting the transformers or the electric distribution system are to be provided:

3.5.2(a) Coordinated Trips of Protective Devices. Discriminative tripping is to be provided for the following. See 4-8-2/9.7.

- i) Between the primary side protective device of the transformer and the feeder protective devices on the low-voltage ship service switchboard, or
- ii) Between the secondary side protective device of the transformer, if fitted, and the feeder protective devices on the low-voltage ship service switchboard.

3.5.2(b) Load Shedding Arrangement. Where the power is supplied through a single set of three-phase transformer to a low-voltage ship service switchboard, automatic load shedding arrangements are to be provided when the total load connected to the low voltage ship service switchboard exceeds the rated capacity of the transformer. See 4-8-1/5.1.5 and 4-8-2/9.9.

3.5.2(c) Protection from Electrical Disturbance. Means or arrangements are to be provided for protecting the transformers from voltage transients generated within the system due to circuit conditions, such as high-frequency current interruption and current suppression (chopping) as the result of switching, vacuum cartridge circuit breaker operation, or thyristor-switching.

3.5.2(d) Protection from Earth-faults. Where a Y-neutral of three-phase transformer windings is earthed, means for detecting an earth-fault are to be provided. The detection of the earth fault is to activate an alarm at the manned control station or to automatically disconnect the transformer from the high-voltage power distribution network.

3.5.2(e) Transformers Arranged in Parallel. Refer to 4-8-2/9.19.3 for requirements.

3.5.3 Voltage Transformers for Control and Instrumentation

Voltage transformers are to be provided with overload and short-circuit protection on the secondary side.

3.5.4 Fuses

Fuses are not to be used for overload protection.

3.5.5 Overvoltage Protection

Lower voltage systems supplied through transformers from high voltage systems are to be protected against overvoltages. This may be achieved by:

- i) Direct earthing of the lower voltage system,
- ii) Appropriate neutral voltage limiters, or
- iii) Earthed screen between primary and secondary winding of transformers

3.5.6 Coordination of Protective Devices

Regardless of the neutral arrangement, coordination of protective devices, in accordance with the intent of 4-8-2/9.7, is to be provided.

3.7 Equipment Design

3.7.1 Air Clearance and Creepage Distance

3.7.1(a) *Air Clearance.* Phase-to-phase air clearances and phase-to-earth air clearances between non-insulated parts are to be not less than the minimum, as specified below.

Nominal Voltage kV	Minimum Air Clearance mm (in.)
3 - 3.3	55 (2.2)
6 - 6.6	90 (3.6)
10 - 11	120 (4.8)
15	160 (6.3)

Where intermediate values of nominal voltages are accepted, the next higher air clearance is to be observed.

3.7.1(b) *Reduction.* Alternatively, reduced clearance distances may be used provided:

- i) The equipment is not installed in 'Machinery Spaces of Category A' or in areas affected by a Local Fixed Pressure Water-spraying or Local Water-mist Fire Extinguishing System.
- ii) The equipment is subject to an impulse voltage test with test voltage values shown in Table below. Where intermediate values of rated operational voltage are used, the next higher rated impulse withstand test voltage is to be used. The impulse voltage test reports are to be submitted to ABS for review.

Rated Voltage kV	Rated Impulse Withstand Voltage kV (peak value)
3.6	40
7.2	60
12	75
15	95

3.7.1(c) *Insulating Material.* Any insulating material that is used to cover live parts of equipment used to comply with clearance distance requirements is to be suitable for the application. The equipment manufacturer is to submit documentation which demonstrates the suitability of such insulation material.

3.7.1(d) *Creepage Distance.* Creepage distances between live parts and between live parts and earthed metal parts are to be in accordance with IEC 60092-503 for the nominal voltage of the system, the nature of the insulation material, and the transient overvoltage developed by switch and fault conditions.

- i) The minimum creepage distances for main switchboards and generators are given in the Table below:

Nominal Voltage V	Minimum Creepage Distance for Proof Tracking Index mm (in.)			
	300 V	375 V	500 V	>600 V
1000-1100	26 (1.02) ⁽¹⁾	24 (0.94) ⁽¹⁾	22 (0.87) ⁽¹⁾	20 (0.79) ⁽¹⁾
< 3300	63 (2.48)	59 (2.32)	53 (2.09)	48 (1.89)
< 6600	113 (4.45)	108 (4.25)	99 (3.9)	90 (3.54)
≤ 11000 ⁽²⁾	183 (7.20)	175 (6.89)	162 (6.38)	150 (5.91)

Notes:

- 1 A distance of 35 mm is required for busbars and other bare conductors in main switchboards.
- 2 Creepage distances for equipment with nominal voltage above 11 kV shall be subject to consideration.

- ii) *Creepage Distances.* The minimum creepage distances for equipment other than main switchboards and generators are given in the Table below:

Nominal Voltage V	Minimum Creepage Distance for Proof Tracking Index mm (in.)			
	300 V	375 V	500 V	>600 V
1000-1100	18 (0.71)	17 (0.67)	15 (0.59)	14 (0.55)
< 3300	42 (1.65)	41 (1.61)	38 (1.50)	26 (1.02)
< 6600	83 (3.27)	80 (3.15)	75 (2.95)	70 (2.76)
≤ 11000*	146 (5.75)	140 (5.51)	130 (5.11)	120 (4.72)

* Note: Creepage distances for equipment with nominal voltage above 11 kV shall be subject to consideration.

3.7.2 Circuit Breakers and Switches – Auxiliary Circuit Power Supply Systems

3.7.2(a) *Source and capacity of power supply.* Where electrical energy or mechanical energy is required for the operation of circuit breakers and switches, a means of storing such energy is to be provided with a capacity at least sufficient for two on/off operation cycles of all of the components. However, the tripping due to overload or short circuit, and undervoltage is to be independent of any stored electrical energy sources. This does not preclude the use of stored energy for shunt tripping, provided that alarms are activated upon loss of continuity in the release circuits and power supply failures. The stored energy may be supplied from within the circuit in which the circuit breakers or switches are located.

3.7.2(b) *Number of external sources of stored energy.* Where the stored energy is supplied from a source external to the circuit, such supply is to be from at least two sources so arranged that a failure or loss of one source will not cause the loss of more than one set of generators and/or essential services. Where it will be necessary to have the source of supply available for dead ship startup, the source of supply is to be provided from the emergency source of electrical power.

3.7.3 Rotating Machines

3.7.3(a) *Protection.* Refer to 4-8-5/Table 1 for ingress protection (IP) requirements.

3.7.3(b) *Winding.* Generator stator windings are to have all phase ends brought out for the installation of the differential protection.

3.7.3(c) *Temperature Detectors.* Rotating machines are to be provided with temperature detectors in their stator windings to actuate a visual and audible alarm in a normally attended position whenever the temperature exceeds the permissible limit. If embedded temperature detectors are used, means are to be provided to protect the circuit against overvoltage.

3.7.3(d) *Space Heater.* Effective means are to be provided to prevent the accumulation of moisture and condensation within the machines when they are idle.

3.7.4 Switchgear and Control-gear Assemblies

Switchgear and control gear assemblies are to be constructed according to the IEC Publication 62271-200 and the following additional requirements:

3.7.4(a) *Mechanical Construction and Configuration*

- i) Switchgear is to be of metal-enclosed type in accordance with IEC Publication 62271-200 or of the insulation-enclosed type in accordance with IEC Publication 62271-201.
- ii) Refer to 4-8-2/3.13 for requirements for the division of main bus bars.

3.7.4(b) *Locking Facilities.* Withdrawable circuit breakers and switches are to be provided with mechanical locking facilities in both service and disconnected positions. For maintenance purposes, key locking of withdrawable circuit breakers, switches and fixed disconnectors are to be possible. Withdrawable circuit breakers, when in the service position, are to have no relative motion between fixed and moving parts.

3.7.4(c) *Shutters.* The fixed contacts of withdrawable circuit breakers and switches are to be so arranged that in the withdrawn position, the live contacts of the bus bars are automatically covered. Shutters are to be clearly marked for incoming and outgoing circuits. This may be achieved with the use of colors or labels.

3.7.4(d) *Earthing and Short-circuiting Facilities.* For maintenance purposes, an adequate number of earthing and short-circuiting facilities are to be provided to enable equipment and cables to be earthed or short-circuited to earth before being worked upon.

3.7.4(e) *Arc Flash and Associated Installation Requirements*

- i) Internal Arc Classification (IAC). Switchgear and control gear assemblies are to be Internal Arc Classified (IAC). Where switchgear and control gear are accessible by authorized personnel only accessibility Type A is sufficient (IEC 62271-200; Annex AA; AA 2.2). Accessibility Type B is required if accessible by non-authorized personnel. Installation and location of the switchgear and control gear is to correspond with its internal arc classification and classified sides (F, L and R).
- ii) Calculations, in accordance with the applicable parts of Standard IEEE 1584 or other recognized standard, are to be made to establish:
 - The maximum current that can flow in the case of an arc fault
 - The maximum time and current that could flow if arc protection techniques are adopted
 - The distance, from the location of the arc flash, at which the arc flash energy would be 1.2 calories per cm² if the enclosure is open
- iii) In addition to the marking required by the equipment design standard, arc flash data consistent with the Design Operating Philosophy and the required PPE is also to be indicated at each location where work on the HV equipment could be conducted.

3.7.5 Transformers

3.7.5(a) *Application.* The provisions of 4-8-5/3.7.5 are applicable to power transformers for essential services. See also 4-8-3/7.3. Items 4-8-5/3.7.5(c) and 4-8-5/3.7.5(d) are applicable to transformers of the dry type only. These requirements are not applicable to transformers intended for the following services:

- Instrument transformers
- Transformers for static converters
- Starting transformers

Dry type transformers are to comply with the applicable Parts of the IEC Publication 60076-11. Liquid filled transformers are to comply with the applicable Parts of the IEC 60076 Series. Oil immersed transformers are to be provided with the following alarms and protections:

- Liquid level (Low) – alarm
- Liquid temperature (High) – alarm
- Liquid level (Low) – trip or load reduction
- Liquid temperature (High) – trip or load reduction
- Gas pressure relay (High) – trip

3.7.5(b) Plans. In addition to the details required in 4-8-3/7, the applicable standard of construction and the rated withstanding voltage of the insulation are also to be submitted for review.

3.7.5(c) Enclosure. Transformers are to have a degree of protection, in accordance with 4-8-5/Table 1, but not less than IP23. However, when installed in spaces accessible to unqualified personnel, the degree of protection is to be increased to IP44. For transformers not contained in enclosures, see 4-8-5/3.11.

3.7.5(d) Space heater. Effective means to prevent accumulation of moisture and condensation within the transformers (when de-energized) is to be provided.

3.7.5(e) Testing. Three-phase transformers or three-phase bank transformers of 100 kVA and above are to be tested in the presence of the Surveyor. The test items are to be in accordance with the standard applicable to the transformer. In addition, the tests required in 4-8-3/7.3.5 are also to be carried out in the presence of the Surveyor for each individual transformer. Transformers of less than 100 kVA will be accepted, subject to a satisfactory performance test conducted to the satisfaction of the Surveyor after installation.

Specific requirements are applicable for the following tests:

- i)* In the dielectric strength test, the short duration power frequency withstand voltage to be applied is to follow the standard applicable to the transformer, but not less than the estimated voltage transient generated within the system. If the short duration power frequency withstand voltage is not specified in the applicable standard, IEC 60076-3 is to be referred to. For the voltage transient, see 4-8-5/3.5.2(c).
- ii)* The induced overvoltage withstand test (layer test) is also to be carried out in accordance with the standard applicable to the transformers in the presence of the Surveyor. This test is intended to verify the power-frequency withstand strength along the winding under test and between its phase (strength between turns and between layers in the windings). If the induced overvoltage withstand test is not specified in the applicable standard, IEC 60076-3 is to be referred to.

3.7.5(f) Nameplate. In addition to the requirements in 4-8-3/7.3.5, the following information is also to be indicated on the nameplate:

- Applicable standard
- Short duration power frequency withstand voltage for verification of insulation level of each winding

3.7.6 Cables

3.7.6(a) Standards. Cables are to be constructed to IEC Publication 60092-353, 60092-354, or other recognized standard. See also 4-8-3/9.

3.9 Cable Installation

3.9.1 Runs of Cables

In accommodation spaces, high voltage cables are to be run in enclosed cable transit systems.

3.9.2 Segregation

High voltage cables of different voltage ratings are not to be installed in the same cable bunch, duct, pipe or box.

Where high voltage cables of different voltage ratings are installed on the same cable tray, the air clearance between cables is not to be less than the minimum air clearance for the higher voltage side in 4-8-5/3.7.1(a). However, high voltage cables are not to be installed on the same cable tray for the cables operating at the nominal system voltage of 1 kV or less.

3.9.3 Installation Arrangements

High voltage cables are to be installed on cable trays or equivalent when they are provided with a continuous metallic sheath or armor which is effectively bonded to earth; otherwise, they are to be installed for their entire length in metallic casings effectively bonded to earth.

3.9.4 Termination and Splices

Terminations in all conductors of high voltage cables are to be, as far as practicable, effectively covered with suitable insulating material. In terminal boxes, if conductors are not insulated, phases are to be separated from earth and from each other by substantial barriers of suitable insulating materials. High voltage cables of the radial field type, i.e., having a conductive layer to control the electric field within the insulation, are to have terminations which provide electric stress control.

Terminations are to be of a type compatible with the insulation and jacket material of the cable and are to be provided with means to ground all metallic shielding components (i.e., tapes, wires etc.). See also 4-8-3/9.19 and 4-8-4/21.3.

Splices and joints are not permitted in propulsion cables, (See 4-8-5/5.15.3). For purposes of this Rule, propulsion cables are those cables whose service is related only to propulsion.

3.9.5 Marking

High voltage cables are to be readily identifiable by suitable marking.

3.9.6 Cable Rating

The rated phase to earth voltage (U_o) of high voltage cables shall not be less than shown in the Table below:

Nominal System Voltage (U_n) (kV)	Highest System Voltage (U_m) (kV)	Rated Phase to Earth Voltage (U_o) (kV)	
		Systems with Automatic Disconnection Upon Detection of an Earth Fault	Systems without Automatic Disconnection Upon Detection of an Earth Fault
3.0	3.6	1.8	3.6
3.3	3.6	1.8	3.6
6.0	7.2	3.6	6.0
6.6	7.2	3.6	6.6
10.0	12.0	6.0	10.0
11.0	12.0	6.0	11.0
15.0	17.5	8.7	15.0

3.9.7 Cable Current Carrying Capacities

The maximum current carrying capacity of high voltage cables is to be in accordance with the Table below:

Conductor Size (mm ²)	Maximum Current in Amperes 45°C Ambient; 1000 V and More			
	1-Core		3-Core	
	85°C	90°C	85°C	90°C
16	80	85	55	60
25	105	115	75	80
35	130	140	90	95
50	165	175	115	120
70	205	215	140	150
95	245	260	170	185
120	285	305	200	210
150	330	350	230	245
185	375	400	260	280
240	440	470	310	325
300	505	540	355	375
400	605	645	425	450
500	700	740	490	520

3.10 High Voltage Shore Connection (HVSC)

Vessels equipped with a high voltage shore connection designed to power the vessel with the shore power alone, enabling the shipboard generators to be shut down while in port, are to comply with the requirements given in the *ABS Guide for High Voltage Shore Connection*.

3.11 Equipment Installation

3.11.1 Voltage Segregation

Higher voltage equipment is not to be combined with lower voltage equipment in the same enclosure, unless segregation or other suitable measures are taken to ensure safe access to lower voltage equipment.

3.11.2 Large Equipment Enclosure

Where high voltage equipment is not contained in an enclosure but a room forms the enclosure of the equipment, the access doors are to be so interlocked that they cannot be opened until the supply is isolated and the equipment earthed down. At the entrance of such spaces, a suitable marking is to be placed which indicates danger of high voltage and the maximum voltage inside the space. For high voltage equipment installed outside these spaces, a similar marking is to be provided. An adequate, unobstructed working space is to be left in the vicinity of high voltage equipment for preventing potential severe injuries to personnel performing maintenance activities. In addition, the clearance between the switchboard and the ceiling/deckhead above is to meet the requirements of the Internal Arc Classification according to IEC 62271-200.

3.11.3 Spaces Containing High Voltage Equipment

All entrances to spaces containing high voltage equipment are to have suitable marking indicating the danger of high voltage and the maximum voltage inside the space.

Where the spaces contain high voltage switchgear the marking at the entrances is also to include marking indicating that the space is only accessible to authorized personnel only.

3.11.4 Exposure of HV Equipment to Damaging Environments

Consideration should be given to designing the arrangement of the installation to avoid exposure of high voltage equipment to contaminants, such as oil or dust, as might be found in machinery spaces or close to ventilation air inlets to the space, or to water spray from water-mist systems and local fire hose connections.

3.13 Tests

3.13.1 Rotating Machine Tests

Each design of HV generator and motor is to be assessed by testing in accordance with the “type tests” schedule indicated in 4-8-3/Table 3. Each subsequent production unit of and accepted design is to be tested in accordance with the “routine tests” schedule also indicated in 4-8-3/Table 3.

3.13.1(a) Inter-turn Insulation Test. In addition to the tests normally required for rotating machinery, a high frequency high voltage test in accordance with IEC Publication 60034-15 is to be carried out on the individual coils in order to demonstrate a satisfactory withstand level of the inter-turn insulation to steep fronted switching surges.

3.13.1(b) Immediately after the high voltage test the insulation resistance is to be measured using a direct current insulation test meter between:

- i) All current carrying parts connected together and earth
- ii) All current carrying parts of different polarity or phase where both the ends of each polarity or phase are individually accessible.

The minimum values of test voltage and corresponding insulation resistance are given in the table below. The insulation resistance is to be measured close to the operating temperature. If this is not possible then an approved method of calculation is to be used.

Rated Voltage U_n (V)	Minimum Test Voltage (V)	Minimum Insulation Resistance (M Ω)
$1000 < U_n \leq 7200$	1000	$U_n/1000 + 1$
$7200 < U_n \leq 15000$	5000	$U_n/1000 + 1$

3.13.2 Switchgear Tests

A power frequency voltage test is to be carried out on high voltage switchgear and control-gear assemblies with test voltages shown in the Table below. The test procedure is to be in accordance with IEC Publication 62271-200 Section 7/ *Routine Test*.

Rated Voltage (kV)	Rated Power Frequency Withstand Voltage (kV)
3.6	10
7.2	20
12	28
15	38

Where intermediate values of switchgear rated voltages are used, the next higher power frequency withstand test voltage is to be used.

3.13.3 Cable Test after Installation (1 July 2016)

A voltage withstand test is to be carried out on each completed cable and its accessories before a new high voltage installation, including additions to an existing installation, is put into service.

An insulation resistance test is to be carried out prior to the voltage withstand test being conducted.

For cables with rated voltage (U_o/U) above 1.8/3 kV ($U_m = 3.6$ kV) an AC voltage withstand test may be carried out upon advice from high voltage cable manufacturer. One of the following test methods to be used:

- i) An AC test voltage for 5 min with the phase-to-phase voltage of the system applied between the conductor and the metallic screen/sheath.
- ii) An AC voltage test for 24 h with the normal operating voltage of the system.
- iii) A DC test voltage equal to $4U_o$ may be applied for 15 minutes.

For cables with rated voltage (U_o/U) up to 1.8/3 kV ($U_m = 3.6$ kV), a DC voltage equal to $4U_o$ shall be applied for 15 minutes.

After completion of the test, the conductors are to be connected to earth for a sufficient period in order to remove any trapped electric charge.

The insulation resistance test is then repeated.

The above tests are for newly installed cables. If due to repairs or modifications, cables which have been in use are to be tested, lower voltages and shorter durations should be considered.

3.15 Design Operating Philosophy

3.15.1 Objective

While this section covers the specific ABS requirements for High Voltage (HV) systems, it is recognized that system design and equipment construction are only parts of an overall approach that are required to allow HV systems to be operated safely. Other aspects that contribute towards HV safety include maintenance procedures, vessel and equipment operating procedures, permit to work procedures, company safety policy, personal protective equipment (PPE) and training, most of which are beyond the role of Classification. However, in order to assist ABS in its review of the design and construction of the vessel and its equipment it is necessary for ABS to be assured that the design is part of a larger overall approach or plan.

The High Voltage Design Principles document is to outline the concepts that are the basis of the design. It should identify risks and document the strategies that are used to mitigate each of the risks (e.g., remote switching, arc flash energy reduction equipment).

3.15.2 HV System Failures

The design should take into account each reasonably foreseeable failure type and address what actions will be expected of the crew for each failure. Due to the limited availability of specialist tools, equipment and spare parts on board and recognizing the additional dangers associated with space limitations, the remoteness of specialized medical help and facilities in the event of emergencies, it is desirable that, as far as practicable, the crew is not exposed to dangers that could be avoided. For these reasons it is preferable that the vessel's HV electrical system be designed such that the crew can safely isolate any damaged distribution equipment and switch to alternative supplies without the need to open the HV equipment.

3.15.3 Activities

For all HV switchboards and distribution boards, each type of operation or activity is to be identified and the means of undertaking the operation or activity safely is to be established. The operations and activities to be considered are to include the following:

- i) Taking readings
- ii) Normal operational switching
- iii) Isolation and making safe
- iv) Maintenance
- v) Fault finding
- vi) Inspection
- vii) Class Surveys

Where switchgear design calls for circuit breakers to be inspected prior to being put back into service following operation on overcurrent, this should also be covered.

3.15.4 Accessibility

An adequate, unobstructed working space of at least 2 m (6 ft) is to be left in the vicinity of high voltage equipment for preventing potential severe injuries to personal performing maintenance activities. Where the clear space around a location where activity is taking place is less than 2 m (6 ft), then the activities are to be covered in sufficient detail to take into account the work involved and the possible need to have clear and safe access for emergency medical evacuation. Where recommended by the switchgear manufacturer, the working space may be reduced to a minimum of 1.5 m (5 feet) due to special considerations such as the use of arc resistant switchgear.

Activities that do not require operation at the switchboard (e.g., telephones or manual call points) should not require the operator to be within 2 m (6 ft) of the switchboard.

3.15.5 Modifications

No modifications are to be made to HV switchgear without the plans being approved and the drawings being made available to the ABS Surveyor in advance of the work taking place. Testing of approved modifications is to be conducted in the presence of the ABS Surveyor. Temporary repairs are to be in full compliance with the requirements of these Rules.

3.15.6 HV Systems with Enhanced Operating Redundancy

Where the HV electrical system is designed with sufficient redundancy to allow switching and isolation along the principles in 4-8-5/3.15.2 and still meet the requirements of 4-8-2/3.1.1 with one generator in reserve, then the activity associated with that failure is not required to be included.

3.17 Preliminary Operations Manual

3.17.1 Objective

The preliminary operations manual contains the shipyard's description of operations affecting the vessel's HV equipment. The description 'preliminary' is used to capture the fact that it may not be the final document used by the vessel's Owner.

The manual is to be complete and sufficiently detailed to capture each piece of HV equipment and how the activities associated with that equipment can be achieved consistently with the Design Operating Philosophy. This manual is to be made available to the Owner by the shipyard.

The Owner will need the information contained in the preliminary operations manual to understand how the shipyard designed the HV equipment to be operated safely. It is likely that the Owner will modify some aspects of the manual to bring it in line with their own company policies, organizational responsibilities and legal duties.

The preliminary operations manual is to include for each piece of HV equipment:

- i) Details of the tasks (operations and activities) associated with that piece of equipment
- ii) Details of the 'Authorization' needed to perform each of the tasks
- iii) Details of the tools required to perform each of the tasks
- iv) Details of PPE and safety equipment (locks, barriers, tags, rescue hooks, etc.)
- v) Identify the tasks for which a 'permit to work' system is to be used.

3.17.2 Details of Authorization

For each operation or task involving HV switchgear and for access to the HV switchgear rooms, the appropriate authorizations are to be determined before delivery.

3.17.3 Training Requirements for Authorization

Part of the basis of establishing any level of authorization is training. It is not expected that the shipyard will stipulate what training qualifications are required. However, a description of the subjects that would need to be covered in the training for each level of authorization should be included.

The Owner can be guided by the above information in making decisions regarding the crew training requirements.

3.17.4 Test, Maintenance Tools and PPE

Where tasks require the use of PPE, the required protection clothing rating should be identifiable in the preliminary operations manual and on a label on the HV equipment where that task will take place. The level of protection offered by the PPE is to be readily identified on the PPE itself in the same terms or units as used on the labels.

Some PPE for general use is not suitable for High Voltage or arc flash hazards, mostly through inappropriate fire performance; such PPE is to be excluded from high voltage switchgear rooms. Information alerting the crew of the need to be able to recognize and use the right PPE is to be included in the manual.

3.17.5 Inspection and Maintenance of Test Equipment Tools and PPE

Where PPE or test equipment is provided by the shipyard the means for its proper use, inspection, calibration and maintenance is to be made available. The instructions or directions regarding where they are kept are to be contained in the Preliminary Operations Manual.

Where the PPE is not provided by the shipyard a description or specification regarding the required tools and PPE should be provided in the Preliminary Operations Manual.

5 Electric Propulsion Systems

5.1 General

5.1.1 Application

The requirements in this Subsection are applicable to electric propulsion systems. Electric propulsion systems complying with other recognized standards will also be considered, provided it can be shown, through either satisfactory service experience or a systematic analysis based on sound engineering principles, to meet the overall safety standards of these Rules.

5.1.2 Plans and Data to be Submitted

In addition to the plans and data to be submitted in accordance with 4-8-1/5, as applicable, the following plans and data are to be submitted for review.

- One-line diagrams of propulsion control system for power supply, circuit protection, alarm, monitoring, safety and emergency shutdown systems including list of alarm and monitoring points.
- Plans showing the location of propulsion controls and its monitoring stations.
- Arrangements and details of the propulsion control console or panel including schematic diagram of the system therein.
- Arrangements and details of electric coupling.
- Arrangements and details of the semiconductor converter enclosure for propulsion system, including data for semiconductor converter, cooling system with its interlocking arrangement.

5.3 System Design

5.3.1 General

For the purposes of the electric propulsion system requirements, an electric propulsion system is one in which the main propulsion of the vessel is provided by at least one electric motor. A vessel may have more than one electrical propulsion system.

An integrated electric propulsion system is a system where a common set of generators supply power to the vessel service loads as well as the propulsion loads.

In the case of an integrated electrical propulsion system, the electrical drive train is considered to consist of the equipment connected to the electrical network such as a drive (frequency converter) and the propulsion motor(s).

All electrical equipment that is part of the electric propulsion drive train is to be built with redundancy such that a single failure will not completely disable the propulsion of the vessel. Where electric motors are to provide the sole means of propulsion for a vessel, a single propulsion motor with dual windings does not meet this requirement.

5.3.2 Generating Capacity

For vessels with an integrated electric propulsion system, under normal sea-going conditions, when one generator is out of service, the remaining generator capacity is to be sufficient to carry all of the loads for vessel services (essential services, normal services and for minimum comfortable conditions of habitability) and the propulsion loads to provide for a speed of not less than 7 knots or one half of the design speed, whichever is the lesser.

5.3.3 Power Management System

For vessels with an integrated electric propulsion system, a power management system is to be provided. The power management system is to be designed to control load sharing between generators, prevent blackouts, maintain power to the essential service loads and maintain power to the propulsion loads.

The system is to account for the following operating scenarios.

- All generators in operation, then the loss of one generator
- When at least one generator is not in operation and there is an increase in the propulsion loads or a loss of one of the generators, that would result in the need to start a generator that was not in operation.
- Upon failure of the power management system, there is to be no change in the available electrical power. Failure of the power management system is to be alarmed at a manned control station.

Further, the system is to prevent overloading the generators, by reducing the propulsion load or load shedding of non-essential loads. In general, the system is to limit power to the propulsion loads to maintain power to the vessel's essential service loads. However, the system is to shed non-essential loads to maintain power to the propulsion loads.

An audible and visible alarm is to be installed at each propulsion control location and is to be activated when the system is limiting the propulsion power in order to maintain power to the other essential service loads.

5.3.4 Regenerative Power

For systems where regenerative power may be developed, the regenerative power is not to cause overspeeding of the prime mover or variations in the system voltage and frequency which exceeds the limits of 4-8-3/1.9. See also 4-8-5/5.17.4(a) and 4-8-5/5.17.4(e).

5.3.5 Harmonics

A harmonic distortion calculation is to be submitted for review for all vessels with electric propulsion. The calculation is to indicate that the harmonic distortion levels at all locations throughout the power distribution system (main generation switchboard, downstream power distribution switchboards, etc.) are within the limits of 4-8-2/7.21.

The harmonic distortion levels at dedicated propulsion buses are also to be within the limits of 4-8-2/7.21, otherwise documentation from the manufacturer is to be submitted indicating that the equipment is designed for operation at a higher level of distortion. Where higher values of harmonic distortion are expected, any other possible effects, such as additional heat losses in machines, network resonances, errors in control and monitoring systems are to be considered.

Means of monitoring voltage harmonic distortion shall be provided, including alarms at the main generation switchboard and at continuously manned stations when to notify of an increase in total or individual harmonic distortion levels above the maximum allowable levels.

Harmonic filters, if used, are to comply with requirements mentioned in 4-8-2/9.23.

5.5 Electric Power Supply Systems

5.5.1 Propulsion Generators

5.5.1(a) Power supply. The power for the propulsion equipment may be derived from a single generator. If a vessel service generator is also used for propulsion purposes other than for boosting the propulsion power, such generator and power supply circuits to propulsion systems are also to comply with the applicable requirements in this Subsection. See also 4-8-2/3.3.

5.5.1(b) Single system. If a propulsion system contains only one generator and one motor and cannot be connected to another propulsion system, more than one exciter set is to be provided for each machine. However, this is not necessary for self-excited generators or for multi-propeller propulsion vessels where any additional exciter set may be common for the vessel.

5.5.1(c) Multiple systems. Systems having two or more propulsion generators, two or more semiconductor converters, or two or more motors on one propeller shaft are to be so arranged that any unit may be taken out of service and disconnected electrically without preventing the operation of the remaining units.

5.5.1(d) Excitation systems. Arrangements for electric propulsion generators are to be such that propulsion can be maintained in case of failure of an excitation system or failure of a power supply for an excitation system. Propulsion may be at reduced power under such conditions where two or more propulsion generators are installed, provided such reduced power is sufficient to provide for a speed of not less than 7 knots or $1/2$ of the design speed, whichever is the lesser.

5.5.1(e) Features for other services. If the propulsion generator is used for other purposes than for propulsion, such as dredging, cargo oil pumps and other special services, overload protection in the auxiliary circuit and means for making voltage adjustments are to be provided at the control board. When propulsion alternating-current generators are used for other services for operation in port, the port excitation control is to be provided with a device that is to operate just below normal idling speed of the generator to remove excitation automatically.

5.5.2 Propulsion Excitation

5.5.2(a) Excitation circuits. Every exciter set is to be supplied by a separate feeder. Excitation circuits are not to be fitted with overload circuit-interrupting devices, except those intended to function in connection with the protection for the propulsion generator. In such cases, the field circuit breaker is to be provided with a discharge resistor unless a permanent discharge resistor is provided.

5.5.2(b) Field circuits. Field circuits are to be provided with means for suppressing voltage rise when a field switch is opened. Where fuses are used for excitation circuit protection, it is essential that they do not interrupt the field discharge resistor circuit upon rupturing.

5.5.2(c) Ship service generator connection. Where the excitation supply is obtained from the ship service generators, the connection is to be made to the generator side of the generator circuit breaker with the excitation supply passing through the overload current device of the breaker.

5.7 Circuit Protection

5.7.1 Setting

Overcurrent protective devices, if any, in the main circuits are to be set sufficiently high so as not to operate on overcurrents caused by maneuvering or normal operation in heavy seas or in floating broken ice.

5.7.2 Direct-current (DC) Propulsion Circuits

5.7.2(a) Circuit protection. Direct-current propulsion circuits are not to have fuses. Each circuit is to be protected by overload relays to open the field circuits or by remote-controlled main-circuit interrupting devices. Provision is to be made for closing circuit breakers promptly after opening.

5.7.2(b) Protection for reversal of the rotation. Where separately driven DC generators are connected electrically in series, means shall be provided to prevent reversal of the rotation of a generator upon failure of the driving power of its prime mover.

5.7.3 Excitation Circuits

An overload protection is not to be provided for opening of the excitation circuit.

5.7.4 Reduction of Magnetic Fluxes

Means are to be provided for selective tripping or rapid reduction of the magnetic fluxes of the generators and motors so that overcurrents do not reach values which may endanger the plant.

5.7.5 Direct-current (DC) Propulsion Motors Supplied by Semiconductor Converters

The protection features of the semiconductor converters are to be arranged to avoid a damaging flashover in the DC propulsion motor. A possible cause of a damaging flashover would be removal of the field current. The protection features of the semiconductor converters are to take into account the increase in armature current created by the removal of the field current, due to accidental loss of the field, or activation of a protection feature intended to protect the field.

To verify compliance with the above, the maximum time-current characteristics that can be commutated by the motor as well as the time-current characteristics of the protective features of the semiconductor converters are to be submitted for review. To avoid a damaging flashover, the maximum time-current characteristics of the motor is to be provided by the motor manufacturer and is to be used by the semiconductor converter manufacturer to determine the appropriate set points for the protection features of the semiconductor converters.

5.9 Protection for Earth Leakage

5.9.1 Main Propulsion Circuits

Means for earth leakage detection are to be provided for the main propulsion circuit and be arranged to operate an alarm upon the occurrence of an earth fault. When the fault current flowing is liable to cause damage, arrangements for opening the main propulsion circuit are also to be provided.

5.9.2 Excitation Circuits

Means are to be provided for earth leakage detection in excitation circuits of propulsion machines, but may be omitted in circuits of brushless excitation systems and of machines rated up to 500 kW.

5.9.3 Alternating-current (AC) Systems

Alternating-current propulsion circuits are to be provided with an earthing detector alarm or indicator. If the neutral is earthed for this purpose, it is to be through an arrangement which will limit the current at full-rated voltage so that it will not exceed approximately 20 A upon a fault to earth in the propulsion system. An unbalance relay is to be provided to open the generator and motor-field circuits upon the occurrence of an appreciable unbalanced fault.

5.9.4 Direct-current (DC) Systems

The earthing detector may consist of a voltmeter or lights. Provision is to be made for protection against severe overloads, excessive currents and electrical faults likely to result in damage to the plant. Protective equipment is to be capable of being so set as not to operate on the overloads or overcurrents experienced in a heavy seaway or when maneuvering.

5.11 Propulsion Control

5.11.1 General

Failure of a control signal is not to cause an excessive increase in propeller speed. The reference value transmitters in the control stations and the control equipment are to be so designed that any defect in the desired value transmitters or in the cables between the control station and the propulsion system will not cause a substantial increase in the propeller speed.

5.11.2 Automatic and Remote Control Systems

Where two or more control stations are provided outside the engine room, or where the propulsion machinery space is intended for centralized control or unattended operation, the provisions of Part 4, Chapter 9 are to be complied with.

5.11.3 Testing and Inspection

Controls for electric propulsion equipment are to be inspected when finished and dielectric strength tests and insulation resistance measurements made on the various circuits in the presence of the Surveyor, preferably at the plant of manufacture. The satisfactory tripping and operation of all relays, contactors and the various safety devices are also to be demonstrated.

5.11.4 Initiation of Control

The control of the propulsion system can be activated only when the delegated control lever is in zero position and the system is ready for operation.

5.11.5 Emergency Stop

Each control station shall have an emergency stop device which is independent of the control lever.

5.11.6 Prime Mover Control

Where required by the system of control, means are to be provided at the control assembly for controlling the prime mover speed and for mechanically tripping the throttle valve.

5.11.7 Control Power Failure

If failure of the power supply occurs in systems with power-aided control (e.g., with electric, pneumatic or hydraulic aid), it is to be possible to restore control in a short time.

5.11.8 Protection

Arrangements are to be made so that opening of the control system assemblies or compartments will not cause inadvertent or automatic loss of propulsion. Where steam and oil gauges are mounted on the main-control assembly, provision is to be made so that the steam or oil will not come in contact with the energized parts in case of leakage.

5.11.9 Interlocks

All levers for operating contactors, line switches, field switches and similar devices are to be interlocked to prevent their improper operation. Interlocks are to be provided with the field lever to prevent the opening of any main circuits without first reducing the field excitation to zero, except that when the generators simultaneously supply power to an auxiliary load apart from the propulsion, the field excitation need only be reduced to a low value.

5.13 Instrumentation at the Control Station

5.13.1 Indication, Display and Alarms

The necessary instruments to indicate existing conditions at all times are to be provided and mounted on the control panel convenient to the operating levers and switches. Instruments and other devices mounted on the switchboard are to be labeled and the instruments provided with a distinguishing mark to indicate full-load conditions. Metallic cases of all permanently installed instruments are to be permanently earthed. The following instruments, where applicable, are to be provided.

- i) For AC systems: ammeter, voltmeter, indicating wattmeter and field ammeter (not required for brushless generators) for each propulsion generator and for each synchronous motor. See also 4-9-6/Table 4.
- ii) For DC systems: an ammeter for each main circuit and one or more voltmeters with selector switches for reading voltage on each propulsion generator and motor. See also 4-9-6/Table 4.
- iii) For electric slip couplings: an ammeter for the coupling excitation circuit.

5.13.2 Indication of Propulsion System Status

The control stations of the propulsion systems are to have at least the following indications for each propeller:

- i) "Ready for operation": power circuits and necessary auxiliaries are in operation.
- ii) "Faulty": propeller is not controllable.
- iii) "Power limitation": in case of disturbance, for example, in the ventilators for propulsion motors, in the converters, cooling water supply or load limitation of the generators.

5.15 Equipment Installation and Arrangements

5.15.1 General

The arrangement of bus bars and wiring on the back of propulsion-control assemblies is to be such that all parts, including the connections, are accessible. All nuts and connections are to be fitted with locking devices to prevent loosening due to vibration. Clearance and creepage distances are to be provided between parts of opposite polarity and between live parts and earth to prevent arcing; see 4-8-3/5.3.2 for low voltage systems and 4-8-5/3.7.1 for high voltage systems.

5.15.2 Accessibility and Facilities for Repairs

5.15.2(a) Accessibility. For purposes of inspection and repair, provision is to be made for access to the stator and rotor coils, and for the withdrawal and replacement of field coils. Adequate access is to be provided to permit resurfacing of commutators and slip-rings, as well as the renewal and bedding of brushes.

5.15.2(b) Facility for supporting. Facilities are to be provided for supporting the shaft to permit inspection and withdrawal of bearings.

5.15.2(c) Slip-couplings. Slip-couplings are to be designed to permit removal as a unit without axial displacement of the driving and driven shaft, and without removing the poles.

5.15.3 Propulsion Cables

Propulsion cables are not to have splices or joints, except terminal joints, and all cable terminals are to be sealed against the admission of moisture or air. Similar precautions are to be taken during installation by sealing all cable ends until the terminals are permanently attached. Cable supports are to be designed to withstand short-circuited conditions. They are to be spaced less than 900 mm (36 in.) apart and are to be arranged to prevent chafing of the cable. See 4-8-4/21.9.2 for cable hangers and cable straps.

5.17 Equipment Requirements

5.17.1 Material Tests

The following materials intended for main propulsion installations are to be tested in the presence of a Surveyor: thrust shafts, line shafts, propeller shafts, shafting for propulsion generators and motors, coupling bolts, and in the case of direct-connected turbine-driven propulsion generators, fan shrouds, centering and retaining rings. Major castings or built-up parts such as frames, spiders and end shields are to be surface inspected and the welding is to be in accordance with the requirements of Chapter 4 of the *ABS Rules for Materials and Welding (Part 2)*.

5.17.2 Temperature Rating

When generators, motors or slip-couplings for electric propulsion are fitted with an integral fan and will be operated at speeds below the rated speed with full-load torque, full-load current or full-load excitation, temperature rise limits, according to 4-8-3/Table 4, are not to be exceeded.

5.17.3 Protection Against Moisture Condensation

Means for preventing moisture condensation, as specified in 4-8-3/3.11.5, is applicable for rotating machines and converters, regardless of the weight of the machines.

5.17.4 Prime Movers

5.17.4(a) Capability. The prime mover rated output is to have adequate overloading and build-up capacity for supplying the power which is necessary during transitional changes in operating conditions of the electrical equipment. When maneuvering from full propeller speed ahead to full propeller speed astern with the vessel making full way ahead, the prime mover is to be capable of absorbing a proportion of the regenerated power without tripping due to overspeed.

5.17.4(b) Speed control. Prime movers of any type are to be provided with a governor capable of maintaining the pre-set steady speed within a range not exceeding 5% of the rated full-load speed for load changes from full-load to no-load.

5.17.4(c) *Manual controls.* Where the speed control of the propeller requires speed variation of the prime mover, the governor is to be provided with means for local manual control as well as for remote control. For turbines driving AC propulsion generators, where required by the system of control, the governor is to be provided with means for local hand control, as well as remote adjustment from the control station.

5.17.4(d) *Parallel operation.* In case of parallel operation of generators, the governing system is to permit stable operation to be maintained over the entire operational speed range of the prime movers.

5.17.4(e) *Protection for regenerated power.* Braking resistors or ballast consumers are to be provided to absorb excess amounts of regenerated energy and to reduce the speed of rotation of the propulsion motor. These braking resistors or ballast consumers are to be located external to the mechanical and electric rotating machines. Alternatively, the amount of regenerated power may be limited by the action of the control system.

5.17.5 Rotating Machines for Propulsion

The following requirements are applicable to propulsion generators and propulsion motors.

5.17.5(a) *Ventilation and protection.* Electric rotating machines for propulsion are to be enclosed ventilated or be provided with substantial wire or mesh screen to prevent personnel injury or entrance of foreign matter. Dampers are to be provided in ventilating air ducts, except when recirculating systems are used.

5.17.5(b) *Fire-extinguishing systems.* Electric rotating machines for propulsion which are enclosed or in which the air gap is not directly exposed are to be fitted with fire-extinguishing systems suitable for fires in electrical equipment. This will not be required where it can be established that the machinery insulation is self-extinguishing.

5.17.5(c) *Air coolers.* Air cooling systems for propulsion generators are to be in accordance with 4-6-5/7.5 for sea chest and 4-6-5/7.7 for two means of circulation. Water-air heat exchangers of rotating propulsion machines for single systems (single generator and single motor), as specified in 4-8-5/5.5.1(b), are to have double wall tubes and be fitted with a leak detector feature to monitor for any water leakage. A visual and audible alarm is to be provided at a normally manned location to indicate detection of such water leakage.

5.17.5(d) *Temperature sensors.* Stator windings of AC machines and interpole windings of DC machines, rated above 500 kW, are to be provided with temperature sensors. See 4-9-6/Table 4.

5.17.5(e) *Generator Excitation.* Excitation current for propulsion generators may be derived from attached rotating exciters, static exciters, excitation motor-generator sets or special purpose generating units. Power for these exciters may be derived from the machine being excited or from any ship service, emergency or special purpose generating units.

5.17.5(f) *Propulsion Motors.* Propulsion motors are to be designed to be capable of withstanding the mechanical and thermal effects of a short-circuit at its terminals.

5.17.6 Direct-current (DC) Propulsion Motors

5.17.6(a) *Rotors.* The rotors of DC propulsion motors are to be capable of withstanding overspeeding up to the limit reached in accordance with the characteristics of the overspeed protection device at its normal operational setting.

5.17.6(b) *Overspeed protection.* An overspeed protection device is to be provided to prevent excessive overspeeding of the propulsion motors due to light loads, loss of propeller, etc.

5.17.7 Electric Couplings

5.17.7(a) *General.* Couplings are to be enclosed ventilated or be provided with wire or mesh screen to prevent personnel injury or the entrance of foreign material. All windings are to be specially treated to resist moisture, oil and salt air.

5.17.7(b) *Accessibility for repairs.* The coupling is to be designed to permit removal as a unit without moving the engine. See also 4-8-5/5.15.2(a).

5.17.7(c) *Temperature rating.* The limits of temperature rise are to be the same as for alternating-current generators given in 4-8-3/Table 4, except that when a squirrel-cage element is used, the temperature of this element may reach such values as are not injurious. Depending upon the cooling arrangements, the maximum temperature rise may occur at other than full-load rating so that heat runs will require special consideration; for this purpose, when an integral fan is fitted, the coupling temperatures are not to exceed the limits in 4-8-3/Table 4 when operated continuously at 70% of full-load rpm, full excitation and rated torque. Temperature rises for insulation materials above 180°C will be considered, provided they are in accordance with a recognized standard.

5.17.7(d) *Excitation.* Excitation is to be provided, as required, for propulsion generators. See 4-8-5/5.17.5(e).

5.17.7(e) *Control equipment.* Electric-coupling control equipment is to be combined with the prime mover speed and reversing control and is to include a two-pole disconnect switch, short-circuit protection only, ammeter for reading coupling current, discharge resistor and interlocking to prevent energizing the coupling when the prime mover control levers are in an inappropriate position.

5.17.7(f) *Nameplates.* Nameplates of corrosion-resistant material are to be provided in an accessible position of the electric coupling and are to contain the following typical details:

- Manufacturer's name, serial number and frame designation
- Rated output and type of rating
- Ambient temperature range
- Rated voltage, speed and temperature rise
- Rated exciter voltage and current

5.17.8 Semiconductor Converters for Propulsion

Semiconductor converters are to comply with the requirements in 4-8-3/8.

5.17.9 Reactors and Transformers for Semiconductor Converters

5.17.9(a) *General.* Interphase reactors and transformers used with semiconductor converters are to conform with the requirements of 4-8-3/7 and the following.

5.17.9(b) *Voltage regulation.* Means to regulate transformer output voltage are to be provided to take care of increase in converter forward resistance and, in addition, to obtain the necessary performance characteristics of the converter unit in which the transformer is used.

5.17.9(c) *High temperature alarm.* See 4-8-3/8.9.2(b).

5.17.10 Switches

5.17.10(a) *General design.* All switches are to be arranged for manual operation and so designed that they will not open under ordinary shock or vibration; contactors, however, may be operated pneumatically, by solenoids, or other means in addition to the manual method which is to be provided unless otherwise approved.

5.17.10(b) *Generator and motor switches.* Switches for generators and motors are preferably to be of the air-break type, but for alternating-current systems, where they are to be designed to open full-load current at full voltage, oil-break switches using nonflammable liquid may be used if provided with leak-proof, nonspilling tanks.

5.17.10(c) *Field switches.* Where necessary, field switches are to be arranged for discharge resistors, unless discharge resistors are permanently connected across the field. For alternating-current systems, means are to be provided for de-energizing the excitation circuits by the unbalance relay and earth relay.

5.17.11 Propulsion Cables

5.17.11(a) *Conductors.* The conductors of cables external to the components of the propulsion plant, other than cables and interconnecting wiring for computers, data loggers or other automation equipment requiring currents of very small value, are to consist of not less than seven strands and have a cross-sectional area of not less than 1.5 mm² (2,960 circ. mils).

5.17.11(b) *Insulation materials.* Ethylene-propylene rubber, cross-linked polyethylene, or silicone rubber insulated cables are to be used for propulsion power cables, except that polyvinyl chloride insulated cables may be used where the normal ambient temperature will not exceed 50°C (122°F).

5.17.11(c) *Impervious metallic sheath.* Impervious metallic sheaths will be considered but are not to be used with single-conductor alternating-current cables.

5.17.11(d) *Inner wiring.* The insulation of internal wiring in main control gear, including switchboard wiring, shall be of flame-retardant quality.

5.17.11(e) *Testing.* All propulsion cables, other than internal wiring in control gears and switchboards, are to be subjected to dielectric and insulation tests in the presence of the Surveyor.

5.17.12 Reduction Gear Safety – Lubrication

Where reduction gears are driven by electric motors, an automatic means is to be fitted to stop the motors in the event of failure of the lubricating oil supply to the reduction gear, (see 4-6-5/5.3.4)

5.19 Trials

Complete tests of the entire electric propulsion system are to be carried out during sea-trials including the following:

- i) Duration runs with the ship at full propulsion load.
- ii) Maneuvering tests which should include a reversal of the vessel from full speed ahead to full speed astern during which important measurements such as system currents, voltages, speed, etc. shall be recorded.
- iii) Tests to check for operation of all protective devices, safety functions, alarms, indicators, control modes and stability tests for control.

All tests necessary to demonstrate that major components of the electric propulsion plant and the system as a whole are satisfactory for duty are to be performed. Immediately prior to trials, the insulation resistance is to be measured and recorded.

7 Three-wire Dual-voltage DC Systems

7.1 Three-wire DC Generators

Separate circuit-breaker poles are to be provided for the positive, negative, neutral and also for the equalizer leads, unless protection is provided by the main poles. When equalizer poles are provided for the three-wire generators, the overload trips are to be of the algebraic type. No overload trip is to be provided for the neutral pole, but it is to operate simultaneously with the main poles. A neutral overcurrent relay and alarm system is to be provided and set to function at a current value equal to the neutral rating.

7.3 Neutral Earthing

7.3.1 Main Switchboard

The neutral of three-wire dual-voltage direct-current systems is to be solidly earthed at the generator switchboard with a zero-center ammeter in the earthing connection. The zero-center ammeter is to have a full-scale reading of 150% of the neutral-current rating of the largest generator and be marked to indicate the polarity of earth. The earth connection is to be made in such a manner that it will not prevent checking the insulation resistance of the generator to earth before the generator is connected to the bus. The neutrals of three-wire DC emergency power systems are to be earthed at all times when they are supplied from the emergency generator or storage battery. The earthed neutral conductor of a three-wire feeder is to be provided with a means for disconnecting and is to be arranged so that the earthed conductor cannot be opened without simultaneously opening the unearthed conductors.

7.3.2 Emergency Switchboard

No direct earth connection is to be provided at the emergency switchboard; the neutral bus or buses are to be solidly and permanently connected to the neutral bus of the main switchboard. No interrupting device is to be provided in the neutral conductor of the bus-tie feeder connecting the two switchboards.

7.3.3 Size of Neutral Conductor

The capacity of the neutral conductor of a dual-voltage feeder is to be 100% of the capacity of the unearthed conductors.

9 Electrical Plants of Less Than 75 kW

9.1 General

Electrical plants having an aggregate capacity of less than 75 kW are to comply with the following requirements and the requirements in this Part 4, Chapter 8, as applicable – except, 4-8-3/1.17, 4-8-1/5.1.3, 4-8-1/5.1.4, 4-8-2/3.1, 4-8-2/3.3, 4-8-2/3.5, 4-8-2/3.9, 4-8-2/3.11, 4-8-2/3.13, 4-8-2/5, 4-8-2/3.7.2, 4-8-2/9.7, 4-8-2/11.3, 4-8-2/11.5, 4-8-2/11.7.1, 4-8-2/11.7.2, 4-8-1/5.3.1, 4-8-4/7.1, 4-8-3/5.3.2, 4-8-3/9 and 4-8-5/3.

9.3 Standard Details

Standard wiring practices and details, including such items as cable supports, earthing details, bulkhead and deck penetrations, cable joints and sealing, cable splicing, watertight and explosion-proof connections to equipment, earthing and bonding connections, etc., as applicable, are to be indicated on the submitted plans or may be submitted in a booklet format.

9.5 Calculations of Short-circuit Currents

In the absence of precise data, the following short circuit currents at the machine terminals are to be assumed:

9.5.1 Direct Current System

Ten times the full load current for generators normally connected (including spare) for each generator capable of being simultaneously connected.

Six times full load current for motors simultaneously in service.

9.5.2 Alternating Current System

Ten times the full load current for generators normally connected (including spare) for each generator capable of being simultaneously connected-symmetrical rms.

Three times full load current of motors simultaneously in service.

9.7 Lightning Protection

A lightning-protection system consisting of a copper spike and a copper conductor of at least 8 mm² (No. 8 AWC) is to be installed on each nonmetallic mast. The spike is to project at least 150 mm (6 in.) above the uppermost part of the vessel, the conductor is to run clear of metal objects and as straight as practicable to the metallic steel structure of the vessel.

9.9 Temperature Ratings

In the requirements contained in 4-8-5/9, an ambient temperature of 40°C (140°F) has been assumed for all locations. Where the ambient temperature is in excess of this value, the total temperature specified is not to be exceeded. Where equipment has been rated on ambient temperature less than that contemplated, consideration will be given to the use of such equipment, provided the total temperature for which the equipment is rated will not be exceeded.

9.11 Generators

Vessels using electricity for propulsion auxiliaries or preservation of cargo are to be provided with at least two generators. These generators are not to be driven by the same engine. The capacity of the generating sets is to be sufficient to carry the necessary load essential for the propulsion and safety of the vessel and preservation of the cargo (if applicable) with any one generator set in reserve. Vessels having only one generator are to be provided with a battery source to supply sufficient lighting for safety.

9.13 Emergency Source of Power

9.13.1 Capacity

The emergency source of electrical power is to have adequate capacity to provide emergency lighting for a period of at least six hours, see 4-8-2/Table 1.

9.13.2 Sources

The emergency power source may be any of the following:

- i) An automatically connected or manually controlled storage battery; or
- ii) An automatically or manually started generator; or
- iii) Relay-controlled, battery-operated lanterns.

9.13.3 Battery Sources

Where the source of electrical power is a battery connected to a charging device with an output of more than 2 kW, the battery is to be located as near as practicable to, but not in the same space as, the emergency switchboard, distribution board or panel.

9.15 Cable Construction

Cables are to have copper conductors constructed in accordance with a recognized standard and are to be of the stranded type, except sizes not exceeding 1.5 mm² (16 AWG) may have solid conductors.

9.17 Switchboards, Distribution Boards and Panels

9.17.1 Installation

Switchboards, distribution box panels and panels are to be installed in dry, accessible and well-ventilated areas. Not less than 610 mm (24 in.) clearance is to be provided in front of switchboards, distribution box panels and panels. When located at the helm or other area adjacent to or part of an open cockpit or weather deck, they are to be protected by a watertight enclosure.

9.17.2 Instrumentation

A voltmeter, ammeter, frequency meter and voltage regulator are to be provided for each generator installed. Control equipment and measuring instruments are to be provided as necessary to insure satisfactory operation of the generator or generators.

9.19 Navigation Running Lights

Mast head, port, starboard and stem lights, when required, are to be controlled by a running light indicator panel. A fused-feeder disconnect switch is to be provided. The rating of the fuses is to be at least twice that of the largest branch fuse and greater than the maximum panel load.

TABLE 1
High Voltage Equipment Locations and Minimum Degree of Protection

Example of Location	Condition of Location	Switchboards, Distribution Boards, Motor Control Centers and Controllers				
		Generators				
		Motors				
		Transformers, Converters				
		Junction/Connection Boxes				
Dry control rooms Authorized Personnel Only	Danger of touching live parts only	IP32	N/A	N/A	IP23	IP44
Dry control rooms		IP42	N/A	N/A	IP44	IP44
Control rooms Authorized Personnel Only	Danger of dripping liquid and/or moderate mechanical damage	IP32	N/A	N/A	IP23	IP44
Control Rooms		IP42	N/A	N/A	IP44	IP44
Above floor plates in machinery spaces Authorized Personnel Only ⁽¹⁾		IP32	IP23	IP23	IP23	IP44
Above floor plates in machinery spaces		IP42	IP23	IP43	IP44	IP44
Emergency machinery rooms Authorized Personnel Only		IP32	IP23	IP23	IP23	IP44
Emergency machinery rooms		IP42	IP23	IP43	IP44	IP44
Below floor plates in machinery spaces Authorized Personnel Only	Increased danger of liquid and/or mechanical damage	N/A	N/A	*	*	IP44
Below floor plates in machinery spaces		N/A	N/A	*	N/A	IP44
Ballast pump rooms Authorized Personnel Only	Increased danger of liquid and mechanical damage	IP44	N/A	IP44	IP44	IP44
Ballast pump rooms		IP44	N/A	IP44	IP44	IP44
Holds for general cargo	Danger of liquid spray presence of cargo dust, serious mechanical damage, and/or aggressive fumes	*	*	*	*	IP55
Open decks ⁽²⁾	Not exposed to seas	N/A	IP56	IP56	IP56	IP56
Open decks ⁽²⁾	Exposed to seas	N/A	N/A	*	*	*

“*” indicates that equipment in excess of 1000 V is not normally permitted in these locations

Notes:

- 1 See 4-8-3/1.11.2 where the equipment is located within areas affected by local fixed pressure water-spraying or water-mist fire extinguishing systems
- 2 For High Voltage Shore Connections (HVSC) see the requirements in the ABS *Guide for High Voltage Shore Connection*
- 3 Where the IP rating of the high voltage electrical equipment has been selected on the basis that it is only accessible to authorized personnel, the entrance doors to the spaces in which such equipment is located, are to be marked accordingly.

4

CHAPTER 9 Automation

CONTENTS

SECTION 1	General Provisions	765
1	Application	765
1.1	Organization of Chapter 9	765
1.3	Scope	766
3	Class Notations	766
3.1	ACC Notation	766
3.3	ACCU Notation.....	766
3.5	ABCU Notation.....	766
3.7	Periodical Survey	766
5	Definitions	766
5.1	General Definitions	766
7	Plans and Data	768
7.1	Specifications	768
7.3	System Design Plans	768
7.5	Equipment Plans	771
7.7	Installation Plans	771
7.9	Test Programs and Operation Manuals.....	771
9	Tests and Surveys	772
9.1	Installation Tests	772
9.3	Periodical Surveys.....	772
SECTION 2	Essential Features Requirements.....	773
1	Application	773
3	Control Systems.....	773
3.1	Conceptual Requirements	773
3.3	Control System Design.....	774
3.5	Control Station Hierarchy	774
3.7	Control Console Instrumentation	775
5	Power Supply	775
5.1	General.....	775
5.3	Electric.....	775
5.5	Hydraulic	775
5.7	Pneumatic	775
7	Monitoring/Alarm Systems.....	775
7.1	Independence of Visual and Audible Alarm Circuits.....	775
7.3	Audible Alarms	775
7.5	Visual Alarms	776
7.7	Acknowledgment of Alarms	776

	7.9	Temporarily Disconnecting Alarms	776
	7.11	Built-in Alarm Testing.....	776
	7.13	Self-Monitoring	776
9		Safety System	776
	9.1	General Requirements.....	776
	9.3	Automatic Safety Shutdown.....	776
	9.5	Remote Propulsion Control Safety System.....	777
11		Remote Propulsion Control System Requirements	778
	11.1	Propulsion and Maneuvering Application.....	778
	11.3	General Requirements.....	778
	11.5	System Design	778
	11.7	System Power Supply.....	779
13		Remote Propulsion Control on Navigation Bridge	779
	13.1	General.....	779
	13.3	Propeller Control.....	779
	13.5	Ordered Speed and Direction	780
	13.7	Emergency Shutdown.....	780
	13.9	Starting of Propulsion Machinery	780
	13.11	Transfer Between Remote Control Stations	780
	13.13	Local Manual Control.....	780
	13.15	Communications Systems	780
15		Remote Propulsion Control Station Other than Navigation Bridge.....	781
	15.1	General.....	781
	15.3	Propulsion Machinery Space	781
	TABLE 1	Typical Fail-safe States Example.....	773
	TABLE 2	Instrumentation and Controllers on Remote Propulsion Control Stations.....	782

SECTION 3 Computer-based Systems 784

1	Application.....	784
3	Definitions.....	784
3.1	Programmable Electronic System (PES)	784
3.3	Interface.....	784
3.5	Peripheral	784
3.7	Software Module.....	784
3.9	Basic Software.....	784
3.11	Application Software	784
3.13	Communication Node	784
3.15	Task Prioritization	785
3.17	Other Terminology	785
5	Systems Requirements.....	785
5.1	General Requirements.....	785
5.3	FMEA.....	786

7	Systems Configuration.....	786
7.1	System Categories	786
7.3	Examples.....	786
9	Software.....	787
9.1	General Principle.....	787
9.3	SDLC.....	787
9.5	Software Documentation and Testing	789
11	Hardware.....	790
11.1	Design for Ease of Maintenance	790
11.3	User Interface and Input Devices	790
11.5	Visual Display Unit	791
11.7	Graphical Display	791
11.9	Hardware Documentation and Testing.....	791
13	Data Communication	792
13.1	Data Communication.....	792
13.3	Wireless Data Communication	792
TABLE 1	System Categories.....	786
TABLE 2	SDLC Tests and Documentation	789
TABLE 3	Tests and Documentation	791
FIGURE 1	V-Model for SDLC.....	787

SECTION 3	Appendix 1 – Definitions and Notes Relating to SDLC and Hardware Test and Evidence Documentation in 4-9-3/Tables 2 and 3	794
1	Concept Phase	794
1.1	Quality Plan for Software.....	794
1.3	Analysis Regarding Existence and Fulfillment of Programming Procedures for Safety Related Functions.....	794
3	Requirements & Design Phase.....	794
3.1	Software Requirements Specification (SRS).....	794
3.3	Software Design Specification (SDS)	794
3.5	Functional Description Document (FDD).....	795
3.7	Software Description	795
3.9	Failure Analysis for Safety Related Functions Only (For Example FMEA).....	795
5	Construction Phase.....	795
5.1	Quality Control in Production.....	795
5.3	Module Tests.....	795
5.5	Subsystem Tests.....	795
5.7	System Tests.....	796
5.9	Integration Tests.....	796
5.11	Fault Simulation.....	796
5.13	Factory Acceptance Test (FAT).....	796
5.15	Final Test Reports	796
5.17	Evidence of Software Testing According to Quality Plan.....	796

7	Verification & Validation Phase.....	796
7.1	Complete System Test	796
7.3	Onboard Integration Tests	796
7.5	Traceability of Software	796
9	Operation & Maintenance Phase.....	796
9.1	Operation & Maintenance Plan.....	796
9.3	Software Version Record.....	797
9.5	Software Modification and Upgrades Record	797
9.7	Tests After Modifications	797
11	Hardware Documentation and Testing	797
11.1	Hardware Description	797
11.3	Inspection of Components (Only Hardware) from Sub-suppliers.....	797
11.5	Type Tests.....	797
13	Wireless Data Communication Tests.....	798

SECTION 3	Appendix 2 – On Board Use and Application of Computer-based Systems.....	799
1	References.....	799
3	Definitions	799
3.1	Stakeholders.....	799
3.3	Objects	800
3.5	Simulation Tests	800
5	System Categories.....	801
5.1	Systems Typically Belonging to Category III.....	801
5.3	Systems Typically Belonging to Category II.....	801
7	Risk Assessment of the System	801
9	Code Production and Testing	802
11	Integration Testing before Installation on Board.....	802
13	Approval of Programmable Devices for Category II and III	802
15	Final Integration and Onboard Testing	802
17	Modifications During Operation.....	803
17.1	Responsibilities.....	803
17.3	Change Management	803
19	System Security	803
21	Requirements for Data Links for Category II and III Systems	803
21.1	General Requirements.....	803
21.3	Specific Requirements for Wireless Data Links	804
23	Quality System.....	804
25	Involvement of System Supplier, System Integrator and Owner	804
	FIGURE 1 Typical Computer-based System.....	800

SECTION 4	Integrated Automation System	806
1	Definitions	806
1.1	IAS	806
1.3	Module Technology	806
3	System Requirements.....	806
3.1	Effective Operation.....	806
3.3	Integrated Automation System Failure	806
3.5	Multi-function Displays and Controls	806
3.7	Hardware Redundancy.....	806
3.9	Interfaces.....	806
3.11	Control Redundancy.....	807
5	FMEA	807
7	Documentation.....	807
SECTION 5	ACC Notation.....	808
1	Application	808
3	System Requirements.....	808
3.1	General.....	808
3.3	System Design	808
3.5	System Power Supply	808
5	Location of Centralized Control Station	809
7	Remote Controls from Centralized Control Station	809
9	Monitoring in Centralized Control Station	809
9.1	Instrumentation.....	809
9.3	Operator Interface	809
9.5	Engineer's Alarm	809
11	Safety System.....	809
13	Specific Requirements for Propulsion and Auxiliary Machinery	810
13.1	Propulsion Diesel Engines.....	810
13.3	Propulsion Gas Turbines	810
13.5	Propulsion Steam Turbines	810
13.7	Electric Propulsion.....	810
13.9	Generators and Electrical Systems	810
13.11	Boilers and Fired Equipment	811
13.13	Propulsion Auxiliaries	811
15	Propulsion Machinery Space	812
15.1	Fuel Oil System Arrangements.....	812
15.3	Bilge Level Monitoring	812
15.5	Fire Safety	813
17	Equipment.....	813
TABLE 1	Instrumentation and Controllers in Centralized Control Station – All Propulsion and Auxiliary Machinery	814

SECTION 6	ACCU Notation.....	816
1	Application.....	816
3	System Requirements.....	816
3.1	General.....	816
3.3	Duration of Unattended Operation.....	816
3.5	System Criteria.....	816
3.7	System Power Supply.....	816
5	Navigation Bridge.....	817
7	Location of Centralized Control Station.....	817
9	Remote Control from Centralized Control Station.....	817
11	Monitoring in Centralized Control Station.....	817
13	Safety Systems.....	817
13.1	General.....	817
13.3	System Design.....	817
13.5	Automatic Start and Changeover.....	817
13.7	Automatic Slowdown.....	818
13.9	Automatic Shutdown.....	818
15	Specific Requirements for Propulsion and Auxiliary Machinery.....	818
15.1	Automatic Starting of Propulsion Auxiliaries.....	818
15.3	Propulsion Steam Turbine.....	818
15.5	Boilers.....	818
17	Propulsion Machinery Space.....	819
19	Monitoring Station in the Engineers' Quarters.....	819
19.1	Engineers' Public Space and Engineers' Cabins.....	819
19.3	Muting the Audible Alarms.....	819
19.5	Communication.....	819
21	Fire Safety.....	820
21.1	Fire Fighting Station.....	820
21.3	Controls at Fire Fighting Station.....	820
21.5	Fire Detection and Alarm Systems.....	821
21.7	Portable Fire Extinguishers.....	821
23	Equipment.....	821
TABLE 1A	Instrumentation and Safety System Functions in Centralized Control Station – Slow Speed (Crosshead) Diesel Engines.....	822
TABLE 1B	Instrumentation and Safety System Functions in Centralized Control Station – Medium and High Speed (Trunk Piston) Diesel Engines.....	825
TABLE 2	Instrumentation and Safety System Functions in Centralized Control Station – Propulsion Steam Turbines.....	827
TABLE 3	Instrumentation and Safety System Functions in Centralized Control Station – Propulsion Gas Turbines.....	828
TABLE 4A	Instrumentation and Safety System Functions in Centralized Control Station – Electric Propulsion.....	829
TABLE 4B	Instrumentation and Safety System Functions in Centralized Control Station – Generator Prime Mover for Electric Propulsion.....	831

TABLE 5A	Instrumentation and Safety System Functions in Centralized Control Station – Propulsion Boiler.....	833
TABLE 5B	Instrumentation and Safety System Functions in Centralized Control Station – Auxiliary Boiler	834
TABLE 6	Instrumentation and Safety System Functions in Centralized Control Station – Auxiliary Turbines and Diesel Engines	835
SECTION 7	Vessels with Compact Propulsion Machinery Spaces.....	837
1	ABCU Notation	837
1.1	General.....	837
1.3	Station in Navigation Bridge	837
1.5	Centralized Monitoring Station	837
1.7	Communications.....	837
SECTION 8	Special Systems	838
1	Control and Monitoring of Doors and Hatches	838
1.1	Application.....	838
1.3	Doors Used While at Sea	838
1.5	Access Doors/Hatches Normally Closed at Sea.....	839
1.7	Bow Doors, Inner Doors, Side Shell Doors and Stern Doors.....	839
1.9	External Doors/Openings	841
SECTION 9	Equipment.....	842
1	Application	842
3	Environmental Test Conditions	842
5	Environmentally Controlled Space.....	842
7	Electric and Electronic Equipment	842
9	Hydraulic Equipment.....	842
11	Pneumatic Equipment.....	842
13	Equipment Tests	843
13.1	Prototype Environmental Testing	843
13.3	Production Unit Certification	843
13.5	Type Approval Program.....	843
15	Equipment.....	843
15.1	Electrical Equipment.....	843
15.3	Computer Based Equipment	843
15.5	Hydraulic and Pneumatic Equipment	843
15.7	Acceptance Tests.....	843
TABLE 1	Type Tests for Control, Monitoring and Safety Equipment.....	844
TABLE 2	Tests for Unit Certification of Control, Monitoring and Safety Equipment.....	852
FIGURE 1	Test Set-up for Conducted Low Frequency Test (See Test No. 13 of 4-9-9/Table 1)	851

SECTION 10	Installation, Tests and Trials	853
1	General	853
3	Equipment Arrangements and Installation.....	853
3.1	Ranges in Ambient Temperatures	853
3.3	Electromagnetic Avoidance	853
3.5	Moisture Condensation.....	853
3.7	Signal Cables Installation	853
3.9	Electrical Grounding	853
3.11	Harsh Environment.....	854
3.13	Protection Against Falling Liquids or Leakage of Fluid Medium.....	854
3.15	Measuring and Sensing Devices	854
3.17	Marking.....	854
5	Sea Trials and Dockside Trials	854
5.1	Propulsion Remote Control.....	854
5.3	Local Manual Control.....	854
5.5	Vessels Receiving ACC Notation	855
5.7	Vessels Receiving ACCU Notation.....	855
5.9	Vessels Receiving ABCU Notation.....	855
SECTION 11	Vessels Less Than 500 GT Having a Length Equal to or Greater Than 20 m (65 ft).....	856
1	General	856
3	Definitions	856
5	Plans to be Submitted.....	856
7	Electrical Cables and Console Wiring.....	856
9	Alarms.....	856
11	Safety System	857
13	Bridge Control of Propulsion Machinery	857
13.1	General.....	857
13.3	Local Control	857
13.5	Bridge Control Indicators	857
15	Requirements for Periodically Unattended Propulsion Machinery Spaces	857
15.1	Fire Protection	857
15.3	Protection Against Flooding.....	858
15.5	Alarms and Displays	858

4

CHAPTER 9 Automation

SECTION 1 General Provisions

1 Application

1.1 Organization of Chapter 9

Part 4, Chapter 9 contains classification requirements for automation. The requirements for automation are organized as follows:

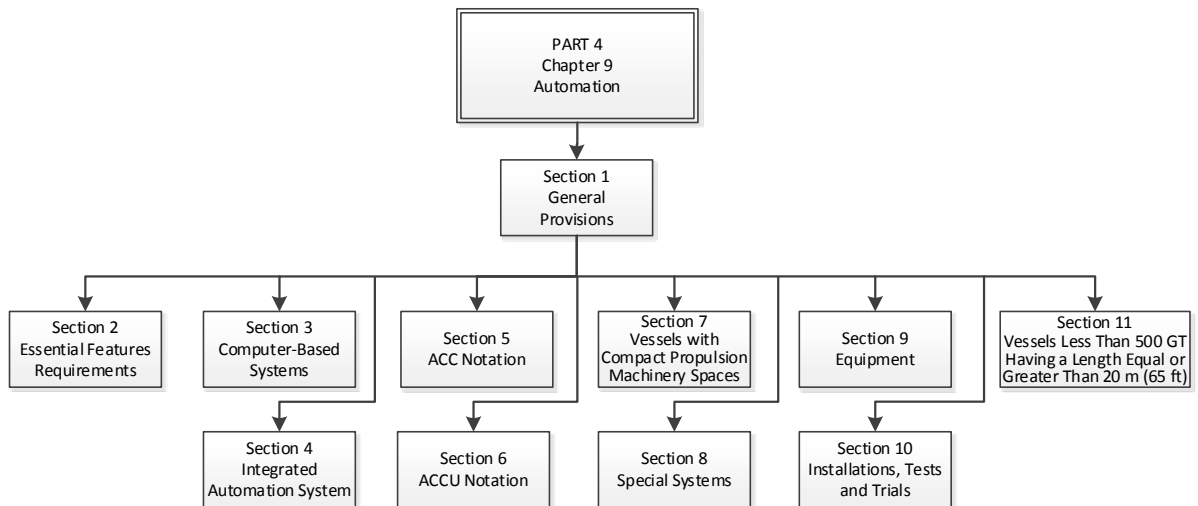

Section 4-9-1 deals with general issues and provides, for example, the required submittals and definitions for terms used throughout the automation systems.

Section 4-9-2 provides the essential features requirements which are all generic requirements for control system, monitoring/alarm system, safety system, power supply, remote propulsion control on navigation bridge and other than on navigation bridge.

Section 4-9-3 provides requirements for computer-based systems which include system categories, software and hardware requirements.

Section 4-9-4 provides Integrated Automation System (IAS) requirements.

Section 4-9-5 provides **ACC** Notation.

Section 4-9-6 provides **ACCU** Notation.

Section 4-9-7 provides the requirements for vessels with compact machinery spaces (no machinery control room and propulsion machinery are controlled only from the navigation bridge), including **ABCU** notation.

Section 4-9-8 provides special systems requirements.

Section 4-9-9 provides requirements for equipment.

Section 4-9-10 provides requirements for installations, tests and trials.

Section 4-9-11 covers the requirements for vessels less than 500 GT having a length equal or greater than 20 m (65 ft).

1.3 Scope

This section applies to electrical, hydraulic, electronic, computer-based systems and equipment for control, monitoring, alarm and safety on board vessels.

3 Class Notations

3.1 ACC Notation

Where, in lieu of manning the propulsion machinery space locally, it is intended to monitor it and to control and monitor the propulsion and auxiliary machinery by qualified personnel from a continuously manned centralized control station, the provisions of Section 4-9-5 are to be complied with. And upon verification of compliance, the class notation **ACC** will be assigned.

3.3 ACCU Notation

Where it is intended that propulsion machinery space be periodically unmanned and that propulsion machinery be controlled from the navigation bridge and a centralized location, the provisions of Section 4-9-6 are to be complied with. And upon verification of compliance, the class notation **ACCU** will be assigned.

3.5 ABCU Notation

Where it is intended that propulsion machinery space be periodically unmanned and that propulsion machinery be controlled from the navigation bridge, the provisions of Section 4-9-7 are to be complied with. And upon verification of compliance, the class notation **ABCU** will be assigned.

3.7 Periodical Survey

The continuance of validity of these notations is subject to periodical survey of the propulsion remote control and automation systems as outlined in Part 7, Chapter 9.

5 Definitions

5.1 General Definitions

5.1.1 Alarm

Visual and audible signals indicating an abnormal condition of a monitored parameter.

5.1.2 Control

The process of conveying a command or order to enable the desired action be effected.

5.1.3 Control System

An assembly of devices interconnected or otherwise coordinated to convey the command or order.

5.1.4 Automatic Control

A means of control that conveys predetermined orders without action by an operator.

5.1.5 Instrumentation

A system designed to measure and to display the state of a monitored parameter and which may include one or more sensors, read-outs, displays, alarms and means of signal transmission.

5.1.6 Local Control

A device or array of devices located on or adjacent to a machine to enable it be operated within sight of the operator.

5.1.7 Remote Control

A device or array of devices connected to a machine by mechanical, electrical, pneumatic, hydraulic or other means and by which the machine may be operated remote from, and not necessarily within sight of, the operator.

5.1.8 Remote Control Station

A location fitted with means of remote control and monitoring.

5.1.9 Monitoring System

A system designed to supervise the operational status of machinery or systems by means of instrumentation, which provides displays of operational parameters and alarms indicating abnormal operating conditions.

5.1.10 Safety System

An automatic control system designed to automatically lead machinery being controlled to a predetermined less critical condition in response to a fault which may endanger the machinery or the safety of personnel and which may develop too fast to allow manual intervention.

To protect an operating machine in the event of a detected fault, the automatic control system may be designed to automatically:

- Slow down the machine or to reduce its demand;
- Start a standby support service so that the machine may resume normal operation; or
- Shut down the machine.

For the purposes of this Chapter, automatic shutdown, automatic slowdown and automatic start of standby pump are all safety system functions. Where “safety system” is stated hereinafter, it means any or all three automatic control systems.

5.1.11 Fail-safe

A designed failure state which has the least critical consequence. A system or a machine is fail-safe when, upon the failure of a component or subsystem or its functions, the system or the machine automatically reverts to a designed state of least critical consequence.

5.1.12 Systems Independence

Systems are considered independent where they do not share components such that a single failure in any one component in a system will not render the other systems inoperative.

5.1.13 Propulsion Machinery

Propulsion machinery includes the propulsion prime mover, reduction gear, clutch, and controllable pitch propellers, as applicable.

5.1.14 Unmanned Propulsion Machinery Space

Propulsion machinery space which can be operated without continuous attendance by the crew locally either in the machinery space or in a centralized control station.

5.1.15 Centralized Control Station

A propulsion control station fitted with instrumentation, control systems and actuators to enable propulsion and auxiliary machinery be controlled and monitored, and the state of propulsion machinery space be monitored, without the need of regular local attendance in the propulsion machinery space.

5.1.16 Failure Mode and Effect Analysis (FMEA)

A failure analysis methodology used during design to postulate every failure mode and the corresponding effect or consequences. Generally, the analysis is to begin by selecting the lowest level of interest (part, circuit, or module level). The various failure modes that can occur for each item at this level are identified and enumerated. The effect for each failure mode, taken singly and in turn, is to be interpreted as a failure mode for the next higher functional level. Successive interpretations will result in the identification of the effect at the highest function level, or the final consequence. A tabular format is normally used to record the results of such a study.

5.1.17 Vital Auxiliary Pumps

Vital auxiliary pumps are those directly related to and necessary for maintaining the operation of propulsion machinery. For diesel propulsion engines, fuel oil pumps, lubricating oil pumps and cooling water pumps are examples of vital auxiliary pumps.

5.1.18 Compact Machinery Spaces

A machinery spaces with no machinery control room and therefore propulsion machinery being controlled only from the navigation bridge.

5.1.19 Data Communication Link

A data communication link is a connection between one location to another for the purpose of transmitting and receiving data which can be further segmented into several communication layers, according to international standards such as IEC 61158, ISO/IEC 7498-1 and IEC 61784.

5.1.20 Worst Case Execution Time (WCET)

The WCET of a computational task is the maximum length of time the task could take to execute on a specific hardware platform.

5.1.21 Worst Case Response Time (WCRT)

The WCRT is the maximum time taken from the input to the sensor (or input device), to the output device (final element) completing its required action. This time period includes the time taken for the Programmable Electronic System to carry out any software processing under WCET and communicate with the sensors and final elements.

7 Plans and Data

The following plans and data are to be submitted for review, as applicable. For vessels less than 500 GT having a length equal or greater than 20 m (65 ft), the required plans submissions are in accordance with 4-9-11/5.

7.1 Specifications

A general description of the operation of the system is to be provided. This is to include the system configuration, general arrangements for the vessel and the layout of the propulsion machinery with essential auxiliaries, specifications of main equipment with information of manufacturer's name, type, rating and number of the equipment.

7.3 System Design Plans

7.3.1 Propulsion Control System

7.3.1(a) Schematic diagrams showing connections between all main components (units, modules) of the system, human machine interfaces (HMI) and interfaces with other systems.

- Propulsion control stations (e.g., from navigation bridge, centralized control station, etc.)
- Type and size of propulsion prime movers and auxiliary machinery and electric propulsion motors (if applicable)
- Independent local manual control
- Shaft turning gear interlocking arrangements
- Propulsion manual emergency shutdown
- Control station instrumentation
- Communications systems
- Essential auxiliary machinery and their controls, such as electrical power generating plant, hydraulic or pneumatic power generation, storage, vital auxiliary pumps, etc.
- Power supply arrangement

7.3.1(b) Operational descriptions for the following items:

- Starting of propulsion machinery
- Control transfer
- Critical speed

- Essential auxiliary machinery automatic starting arrangement if fitted
- Power management arrangements where specially required by the Rules

7.3.2 Propulsion Machinery Safety System

Safety systems descriptions may include a list of all monitored parameters with settings for implemented protective actions (e.g., automatic shutdown and automatic slowdown), schematic diagrams showing the connections between the safety devices, control and display units, alarm devices, human machine interface (HMI) and power supply arrangement, as appropriate, and operational descriptions for the following items:

- Initiation of automatic shutdown
- Initiation of automatic slowdown
- Initiation of automatic starting of standby units
- Override of automatic shutdown
- Override of automatic slowdown
- Re-start of propulsion machinery

7.3.3 Propulsion Machinery Monitoring System

Schematic diagrams showing the connections between the sensing devices, control and display units, alarm devices, human machine interfaces (HMI) and power supply arrangement, and description of monitoring systems including a list of alarms and displays including preset parameters for the propulsion machinery and all essential auxiliary machinery and systems the following stations:

- Centralized control station alarm and instrumentation
- Monitoring station in the engineers accommodation
- Navigation bridge instrumentation

7.3.4 Propulsion Boiler

Schematic diagrams and operational descriptions for the following:

- Prevention of excessive steam
- Automatic shutdown
- Automatic ignition
- Trial-for-ignition period
- Automatic burner light off
- Burner primary-air or atomizing steam
- Post purge
- Boiler limit systems
- Modulated air-fuel ratio

7.3.5 Failure Modes and Effect Analysis (FMEA)

Failure modes and effect analysis is to be submitted for review for vessels receiving **ACC**, **ACCU**, **ABCU**, **DPS-2** and **DPS-3** notations, and vessels with integrated propulsion control and automation system. The FMEA is to contain at least the following:

- System block diagrams showing system breakdown and components of interests.
- A tabulation of the following:
 - Systems and components of interests

- Potential failures modes
- Predictable cause associated with each failure mode
- Failure detection means
- Responses of the system to the failures
- Possible consequences of the failures
- Conclusions, comments or recommendations

7.3.6 Fire Safety Arrangements

Schematic diagrams and descriptions of the fire detection and alarm systems, fire precautions, fire extinguishing equipment, and fire fighting station arrangements.

7.3.7 Communication Systems

Schematic diagrams and arrangements of the internal communication systems.

7.3.8 Oil Mist Detection/Monitoring and Alarm

See 4-2-1/7.2.2 for the requirements.

7.3.9 Programmable Electronic System (PES)

The following are to be submitted, as appropriate:

- Block diagram showing the system configuration including the user interface, description of hardware specifications, hardware FMEA, fail-safe features, security arrangements, power supply, and independence of systems (control, monitoring and safety shutdown).
- Software logic flow chart, description of software functions, self-test features and documentation on quality standard of software development and testing.
- Calculations and/or methods used to determine the Worst Case Response Time (WCRT) for 4-9-3/Table 1 Category III Systems' alarms with respect to design data volume and CPU(s) capability including: data communication protocol(s) and the Worst Case Execution Time (WCET) of the alarm processing task(s). This requirement is also applicable to Category III Systems reduced to Category II, due to independent effective back up or other means of averting danger for the control functions (such as mitigation of alarms missing deadlines).
- For integrated systems the documentation are to be submitted verifying independence of the regular alarm, control and safety functions for each of the essential services. Refer to 4-9-1/7.3.5, 4-9-2/3.1.5, 4-9-9/15.3, 4-9-3/5.3, 4-9-3/5.5, 4-9-3/13.1.2, 4-9-4/5 and 4-9-4/7 of the Rules.
- For documentation of software and hardware, refer to 4-9-3/Tables 2 and 3.

7.3.10 Wireless Data Communication Equipment

The following documentation is to be submitted for wireless data communication equipment.

- i)* Documentation which demonstrates that the wireless data communication equipment provides an improvement in the safety of the vessel, compared to wired data communication. See 4-9-3/13.3.3.
- ii)* General details of the wireless system and equipment.
- iii)* Risk analysis. See 4-9-3/13.3.3(a).
- iv)* Evidence of type testing. See 4-9-3/13.3.3(b).
- v)* On-board test schedule. See 4-9-3/13.3.3(c).
- vi)* Details of manufacturer's recommended installation and maintenance practices. Network plan with arrangement and type of antennas and identification of location. Details of the wireless data communication network. See 4-9-3/13.3.3(d).

- vii) Specification of wireless communication system protocols and management functions. See 4-9-3/13.3.3(e).
- viii) Details of radio-frequency and power levels. See 4-9-3/13.3.3(f).
- ix) For functions that are provided with an alternative means of control, a description of the functions and a description of the alternative means of control. See 4-9-3/13.3.3(a).

7.5 Equipment Plans

Schematic diagrams with a list of major electrical, electronic, hydraulic and pneumatic equipment/components (including manufacturer's names, model names, material, ratings, degree of protection and permissible angles of inclination), function descriptions, construction plans, outline view and elevation details, certificates or test reports as appropriate attesting to the suitability to the intended services and operating conditions in compliance with the environmental criteria set forth in Section 4-9-8.

- Navigation bridge console
- Centralized control and monitoring console
- Safety systems and devices
- Computer based systems, see Section 4-9-3
- Hydraulic equipment
- Pneumatic equipment

7.7 Installation Plans

7.7.1 Installation Arrangements

Locations of centralized control station and remote control stations on the navigation bridge; arrangements of the centralized control station containing control consoles and other equipment, including glass windows, doors, and ventilation fitting, as applicable.

7.7.2 Electrical One-line Diagrams

Type, size and protection of cables between control and monitoring equipment.

7.7.3 Installation Methods

Installation methods for all power and automatic or remote control and monitoring (electrical, pneumatic and hydraulic). This is to include details of cable or pipe runs, separation of cables of different voltage rating and insulating rating, cable tray laying, deck or bulkhead penetration, prevention of magnetic interference, etc.

7.9 Test Programs and Operation Manuals

The requirements in this section are applicable for vessels with integrated propulsion control and automation systems installed.

7.9.1 Factory Acceptance Tests

Factory acceptance tests (FAT) are the test programs for testing at the manufacturers, to include "description of test configuration and test simulation methods, initial test condition, steps to perform the test, observations during the test and acceptance criteria for each test.

7.9.2 Test Program for Dock and Sea Trials

Test program for dock and sea trials is to include initial test condition, steps to perform the test, observations during the test and acceptance criteria for each test.

7.9.3 Operations Manual

For each vessel, operations manual is to be prepared and submitted solely for verification that the information in the manual, relative to the propulsion control system, is consistent with the design and information considered in the review of the system. One copy of the operations manual is to be kept onboard.

The operations manual is intended to provide guidance for the operator about the specific propulsion control installations and arrangements of the specific vessel. The operations manual is to include but not be limited to the following information.

- A description of all the systems associated with the propulsion control of the vessel, including backup systems and communication systems
- The block diagram showing how the components are functional related, as described in 4-9-1/7.3.1
- A description of the different operational modes and transition between modes.
- Operating instructions for the normal operational mode (and the operational modes after a failure) of the electrical or computer control systems, manual control system, manual local control to each equipment (thrusters, electric motors, electric drives or converters, electric generators, etc.)
- Operating instructions for the systems and equipment, indicated in the above paragraph, during failure conditions
- Maintenance and periodical testing procedure, acceptance criteria, fault identification and repair, list of the suppliers' service net, maintenance log.

9 Tests and Surveys

9.1 Installation Tests

Automatic or remote control and monitoring systems are to be subjected to tests witnessed by the Surveyor during and after installation onboard, as outlined in this Section.

9.3 Periodical Surveys

The continuance of **ACC**, **ACCU** or **ABCU** certification is subject to periodic survey of the automatic or remote control and monitoring systems installation, as outlined in Chapter 8 of the *ABS Rules for Survey After Construction (Part 7)*.

4

CHAPTER 9 Automation

SECTION 2 Essential Features Requirements

1 Application

The provisions of Section 4-9-2 apply to control systems, monitoring systems, alarm systems, safety systems, and automatic or remote controls on board vessels, where fitted.

3 Control Systems

3.1 Conceptual Requirements

The following are conceptual requirements for control system design in general and are to be complied with, except where specially exempted.

3.1.1 Fail-safe

A fail-safe concept is to be applied to the design of all control systems, manual emergency control systems and safety systems. In consideration of its application, due regard is to be given to the safety of individual machinery, the system of which the machinery forms a part and the vessel as a whole. 4-9-2/Table 1 shows the example of typical fail-safe states but is not exhaustive. Refer to 4-9-1/5.1.11 and 4-9-3/5.1.8 of the Rules.

TABLE 1
Typical Fail-safe States Example

<i>System or Component</i>	<i>Typical Fail-safe States</i>
Propulsion speed control	Maintain state
Controllable pitch propeller	Maintain state
Propulsion safety shut down	Maintain state and alarm
Alarm system	Annunciated
Cooling water valve	In most cases open

3.1.2 System Independence

Systems performing different functions (e.g., monitoring systems, control systems, and safety systems) are to be, as much as practicable, independent of each other such that a single failure in one will not render the others inoperative. Specifically, the shutdown function of the safety system is to be independent of control and monitoring systems. However, except for the shutdown functions and automatic start/changeover of the required pumps [see 4-9-6/13.3ii)], common sensors will be acceptable for all other functions.

3.1.3 Local Control

In general, local manual controls are to be fitted to enable safe operation during commissioning and maintenance, and to allow for effective control in the event of an emergency or failure of remote control. The fitting of remote controls is not to compromise the level of safety and operability of the local controls.

3.1.4 Remote Controls

Remote controls are to be arranged to provide the same degree of safety and operability as those provided for local controls. The effects of a control input are to be continuously receivable at the remote control station being in command.

3.1.5 Failure Mode and Effect Analysis (FMEA)

Failure modes and effects analysis (FMEA) may be carried out during system design to investigate if any single failure in control systems would lead to undesirable consequences such as loss of propulsion, loss of propulsion control, etc. The analysis may be qualitative or quantitative.

3.1.6 Transfer of Control

Transfer of controls from a remote control station under operation to other associated remote stations is to be possible by a request from the receiving station and acceptance by the station in operation, or vice versa. All control stations are to have indicators showing which station is in control.

3.1.7 Interlocks

Safety interlocks are to be provided to preclude damage to the controlled machinery, such as means fitted to disable the starting mechanism after designated unsuccessful starting attempts, or when the propulsion shaft turning gear being engaged. Safety interlocks in different parts of the systems are not to be conflict with each other.

3.1.8 Automatic Controls

Automatic control systems are to be designed to maintain the controlled machinery within pre-set parameters under normal working conditions and to ensure that the machinery operates in the correct sequence, time intervals, and stable over the entire control range. Deviation from these pre-set conditions is to force the sequential controls to a safe sequence stage that will not be detrimental to the machinery and overall safety of the vessel. In closed loop system, feedback failures are to initiate an alarm and to keep the system operating either at its present state or moving controlled to zero state. Additionally, adequate arrangements are to be included to disable the automatic control mode and restore manual controls.

3.3 Control System Design

Where an automatic control system is provided, it is to be designed to achieve safe and effective operation.

The design of automatic control systems for systems of essential services is to be such that loss of any automatic control features will automatically lead to shifting the level of control to the next lower step, or to the state of least consequences.

3.5 Control Station Hierarchy

A decreasing authority is to be assigned according to the following orders for ships with more than one control station:

- i) Local controls at the controlled equipment
- ii) Machinery space(s) control station(s), closest to the controlled equipment
- iii) Remote control station(s) outside of machinery spaces
- iv) Navigation bridge (or bridge wing) control station

The control station of higher authority is to be designed to include a supervisory means for transferring control from a station of lower authority at all times, and to block any unauthorized request from any station of lower authority.

For transfer of control between the control stations and the preference of the stations refer to 4-9-2/13.11 of the Rules.

3.7 Control Console Instrumentation

Control console instrumentation is to be sufficiently and clearly arranged as to provide for adequate control and status indication of the controlled machinery. Alarm indicators are to have a physical differentiation from other instrumentation.

5 Power Supply

5.1 General

Where auxiliary energy is required for the functions of control, monitoring and safety systems, power supply is to be arranged so as to ensure the functionalities and the degree of independencies defined in 4-9-2/3.1.2 for these systems at all time during operation. Power source for control, monitoring and safety systems may be electric, hydraulic or pneumatic or a combination thereof. Each power supply is to be monitored and its failure is to be alarmed.

5.3 Electric

Where power supply is electric, each of the control, monitoring and safety systems is to be supplied by a separate circuit. Each of these circuits is to be protected for short circuit and monitored for voltage failure.

5.5 Hydraulic

Where power supply is hydraulic, hydraulic pumps are to be fitted in duplicate. The reservoir is to be of sufficient capacity to contain all of the fluid when drained from the system, maintain the fluid level at an effective working level and allow air and foreign matter to separate out. The pump suction is to be sized and positioned to prevent cavitation or starvation of the pump. A duplex filter, which can be cleaned without interrupting the oil supply, is to be fitted on the discharge side of pumps. The hydraulic fluid is to be suitable for its intended operation. Hydraulic supplies to safety and control systems may be derived from the same source but are to be by means of separate lines.

5.7 Pneumatic

Compressed air for control and monitoring systems is to be supplied from at least two air compressors. The starting air system, where consisting of two air compressors, may be used for this purpose. The system is to be arranged such that a single failure will not result in the loss of air supply. The required air pressure is to be automatically maintained.

Means are to be provided to assure that the compressed air for control and monitoring systems is clean, dry and oil-free to a specification compatible with the control and monitoring equipment. In this regard, the compressors, cooling equipment, filters and dryers are to be selected and arranged as necessary to ensure the quality of the air supplied will comply with the standards or criteria identified by the manufacturers of the pneumatic equipment being installed in the system (e.g. max. solid particle size/density, max. dew point, max. oil content, etc.).

Air supplies to safety systems and control systems may be derived from the same source, but are to be by separate lines incorporating shutoff valves.

7 Monitoring/Alarm Systems

Monitoring/Alarm systems are to have the following detail features.

7.1 Independence of Visual and Audible Alarm Circuits

As much as practicable, a fault in the visual alarm circuits is not to affect the operation of the audible alarm circuits.

7.3 Audible Alarms

Audible alarms associated with machinery are to be distinct from other alarms such as the fire-alarm, general alarm, gas detection alarm, etc., and are to be of sufficient loudness to attract the attention of duty personnel. For spaces of unusually high noise level, a beacon light or similar, installed in a conspicuous place, is to supplement the audible alarm. However, red light beacons are only to be used for fire alarms.

7.5 Visual Alarms

Visual alarms are to be a flashing signal when first activated. The flashing display is to change to a steady display upon acknowledgment. The steady display is to remain activated, either individually or in the summarized fashion, until the fault condition is rectified. Other arrangements capable of attracting the operator's attention to an alarm condition in an effective manner will be considered.

7.7 Acknowledgment of Alarms

Newly activated alarms are to be acknowledged by manual means. This means is to mute the audible signal and change the flashing visual display to steady display. Other alarm conditions, occurring during the process of acknowledgment, are to be alarmed and displayed. The latter alarm is not to be suppressed by the acknowledgment of the former alarm.

The acknowledgment of the alarm at an associated remote control station is not to mute and steady the same alarm signals at the centralized control station.

7.9 Temporarily Disconnecting Alarms

Alarm circuits may be temporarily disabled, for example, for maintenance purposes, provided that such action is clearly indicated at the associated station in control and at the centralized control station, if fitted. Temporarily disabled alarm for initial startup of machinery is to be automatically reactivated after a preset time period. For **ACCU** fire alarm systems, see 4-9-6/21.5.2.

7.11 Built-in Alarm Testing

Audible alarms and visual alarm indicating lamps are to be provided with means of testing that can be operated without disrupting the normal operation of the monitoring systems. Such means are to be fitted in the associated remote stations.

7.13 Self-Monitoring

The monitoring system is to include a self-monitoring mechanism such that a fault (e.g., power failure, sensor failure, etc.) may be detected and alarmed. Additionally, the alarm systems are not to react to normal transient conditions or spurious signals.

9 Safety System

9.1 General Requirements

In addition to complying with 4-9-2/3.1.1 through 4-9-2/3.1.3 and 4-9-2/7, safety systems are also to comply with the following:

- i) Means are to be provided to indicate the detected abnormal parameters which cause the safety action.
- ii) Alarms are to be given on the navigation bridge, at the centralized control station and at local manual control position, as applicable, upon the activation of a safety system. Activation of a safety system is to be recorded.
- iii) Propulsion machinery shutdown by a safety system is not to be designed to restart automatically, unless first actuated by a manual reset.
- iv) A safety system for the protection of one machine unit is to be independent of that of the other units.

9.3 Automatic Safety Shutdown

To avert rapid deterioration of propulsion and auxiliary machinery, the following automatic shutdowns are to be provided, regardless of the mode of control: manual, remote or automatic. These shutdowns are not to be fitted with manual override.

- i) For all diesel engines:
 - Overspeed
 - Lube oil system failure

- ii) For all gas turbines (see 4-2-3/Table 1):
 - Failure of lubricating oil system
 - Failure of flame or ignition
 - High exhaust gas temperature
 - High compressor vacuum
 - Overspeed
 - Excessive vibration
 - Excessive axial displacement of rotors
- iii) For all steam turbines:
 - Failure of lubricating oil system
 - Overspeed
 - Back-pressure for auxiliary turbines
- iv) For all boilers:
 - Failure of flame
 - Failure of flame scanner
 - Low water level
 - Failure of forced draft pressure
 - Failure of control power
- v) For propulsion reduction gears:
 - Shutdown prime movers upon failure of reduction gear lubricating oil system.
 - Where prime movers are diesel engines, shutdown is mandatory for high speed or medium speed diesel engines coupled to a reduction gear.
- vi) For generators:
 - For generators fitted with forced lubrication system only: shutdown prime movers upon failure of generator lubricating oil system (see 4-8-3/3.11.3).
- vii) For propulsion DC motor
 - Overspeed [see 4-8-5/5.17.6(b)]

9.5 Remote Propulsion Control Safety System

9.5.1 General

In all cases, automatic safety shutdowns in 4-9-2/9.3 are to be provided. Other safety system functions, such as automatic startup of standby pump or automatic slowdown, as appropriate, may be provided.

9.5.2 Safety System Alarms

9.5.2(a) Threshold Warning for Safety System Activations. Where the propulsion machinery is capable of remote control from the navigation bridge, regardless of manned or unmanned machinery space, automation systems are to be designed in a manner such that a threshold warning of impending or imminent slowdown or shutdown of the propulsion system is given to the officer in charge of the navigational watch in time to assess navigational circumstances in an emergency.

In particular, the systems are to control, monitor, report, alert and take safety action to slowdown or shutdown propulsion while providing the officer in charge of the navigational watch an opportunity to manually intervene (override), except for those cases where manual intervention will result in total failure of the engine and/or propulsion equipment within a short time, for example, in the case of over speed.

9.5.2(b) *Alarms for Safety System Activations.* Activation of safety system to automatic slowdown or automatic shutdown of propulsion machinery is each to be arranged with individual alarm at remote propulsion control station. Audible alarm may be silenced at the control station, however, visual alarm is to remain activated until it is acknowledged in the machinery space.

9.5.3 Override of Safety System Functions

Automatic slowdowns and automatic shutdowns indicated in 4-9-6/Table 1A through 4-9-6/Table 6 may be provided with override, except that specified in 4-9-2/9.3. Automatic slowdowns and automatic shutdowns where provided in excess of those indicated in 4-9-6/Table 1A through 4-9-6/Table 6 are to be provided with override. Overrides are to be as follows:

- i) The activation of the override is to be alarmed and clearly identifiable at the remote propulsion control station and is to be so designed that it cannot be left activated.
- ii) Overrides fitted on the navigation bridge are to be operable only when the propulsion control is from the navigation bridge.
- iii) The override actuator is to be arranged to preclude inadvertent operation.

9.5.4 Restart of Propulsion Machinery

Propulsion machinery shutdown by safety system is not to resume operation until it is reset manually.

11 Remote Propulsion Control System Requirements

11.1 Propulsion and Maneuvering Application

The provisions of this section are applicable:

- Where it is intended that the propulsion machinery be directly controlled from the navigation bridge or from any remote propulsion control station within or outside the propulsion machinery space;
- Where, in lieu of manning the propulsion machinery space locally, it is intended to monitor it and to control and monitor the propulsion and auxiliary machinery by qualified personnel from a continuously manned centralized control station; or
- Where it is intended that the propulsion machinery space be periodically unmanned.

Provisions for remote control of steering gears and of athwartship or positioning thrusters are given in Section 4-3-4 and Section 4-3-5, respectively.

11.3 General Requirements

The remote propulsion control station is to be:

- i) As effective as local control
- ii) Provided with control of speed and direction of thrust of the propeller
- iii) Provided with instrumentation sufficient to provide the operator with information about the state of the propulsion machinery and the control system itself

11.5 System Design

In general, conceptual requirements in 4-9-2/3.1 are to be applied. Further requirements are provided in 4-9-2/9.5, 4-9-2/13, and 4-9-2/15 hereunder

11.7 System Power Supply

11.7.1 Power Source

Power supply requirements provided in 4-9-2/5, as applicable, are to be complied with. Electric power for control, monitoring and safety systems is to be fed from two feeders, one from the main switchboard or other suitable distribution board and the other from the emergency switchboard or an emergency distribution board. Alternatively, one of the feeders can be connected to a standby power supply from battery and uninterruptible power systems (UPS) having capacity for a service duration of at least 30 minutes, see 4-8-2/5.5, 4-8-3/5.9. The supply status of these feeders is to be displayed and the main power supply failure is to be alarmed. The electric power supply to each of the control, monitoring and safety systems is to be individually monitored. For vessels whose propulsion machinery spaces are intended for centralized or unattended operation (**ACC**, **ACCU** or **ABCU** notation), 4-9-5/3.5 is to be complied with.

In the event of power supply failure, the propulsion prime movers are to continue to operate at the last ordered speed and the propellers at the last ordered direction of thrust until local control is in operation or control power is safely resumed.

11.7.2 Power Supply Transfer

The two feeders are to be connected to a transfer switch in the remote control station. Power supply to controls, monitoring and safety systems may be commonly connected to the transfer switch, where power supply transfer for safety system is independent. The transfer between the power supplies may be effected by manual means at the remote control station. For vessels whose propulsion machinery spaces are intended for centralized or unattended operation (**ACC**, **ACCU** or **ABCU** notation), 4-9-5/3.5 is to be complied with.

11.7.3 System Protection

11.7.3(a) Electrical. Circuits are to be arranged so that a fault in one circuit will not cause maloperation or failure on another circuit or system. It is to be possible to isolate the faulted circuit. Additionally, systems are to be protected against accidental reversal of power supply polarities, voltage spikes and harmonic interference, and in no case is the system's total harmonic distortion to exceed 5%.

11.7.3(b) Hydraulic. Pipe systems subject to pressure build-up that may exceed the rated pressure of the pipe and associated components are to be provided with suitable pressure relief devices fitted on the pump's discharge side. Each relief valve is to be capable of relieving not less than full pump flow with a maximum pressure rise of not more than 10% of the relief valve setting.

11.7.3(c) Pneumatic. The requirements in 4-9-2/11.7.3(b) are to be complied with, as applicable.

13 Remote Propulsion Control on Navigation Bridge

13.1 General

Where propulsion machinery is to be controlled from the navigation bridge, means for control and monitoring are to be as provided in 4-9-2/Table 2. The following control and monitoring features are also to be provided. These requirements do not apply to bridge wing propulsion control stations.

13.3 Propeller Control

The speed, direction of thrust and, where applicable, the pitch of the propeller are to be fully controllable from the navigation bridge under all sailing conditions, including maneuvering. The control is to be performed by a single control device for each independent propeller with automatic performance of all associated services including, where necessary, means of preventing overload of the propulsion machinery. Where multiple propellers are designed to operate simultaneously, they may be controlled by one control device.

13.5 Ordered Speed and Direction

When under navigation bridge control, ordered speed and direction of propulsion machinery, including pitch of propellers, where applicable, are to be indicated at the local propulsion machinery control position, and at the centralized control station, if fitted.

13.7 Emergency Shutdown

A manually operated emergency-stopping device for the propulsion machinery is to be provided on the navigation bridge. This device is to be independent of the remote propulsion control system. The shutdown may only be activated by the deliberate action of the operator, and is to be so arranged as to prevent its inadvertent operation.

13.9 Starting of Propulsion Machinery

Where it is necessary to restart the propulsion machinery in order to reverse it to go astern, means to start the propulsion machinery is to be provided on the navigation bridge. In such cases, and in other cases where propulsion machinery can be started from a remote control station, the following are to be provided:

- i) An alarm to indicate a low level starting medium energy condition (e.g., a low starting air pressure) which is to be set at a level to permit further starting operation.
- ii) A display to indicate starting medium energy level (e.g., starting air pressure).
- iii) Where automatic starting of the propulsion machinery is fitted, the number of consecutive automatic attempts is to be limited in order to safeguard sufficient capacity for local manual starting.
- iv) Starting of the propulsion machinery is to be automatically inhibited where conditions exist which may damage the propulsion machinery (e.g., shaft-turning gear engaged, insufficient lubricating oil pressure, etc.). The activation of such inhibition is to be alarmed at the remote control station.

13.11 Transfer Between Remote Control Stations

Remote control of the propulsion machinery is to be possible only from one location at a time. At each location, there is to be an indicator showing which location is in control of the propulsion machinery. The following protocol is to be observed for transfer of control between stations:

- i) The transfer of propulsion control between stations is to take effect only with acknowledgment by the receiving station. This, however, does not apply to transfer of control between the centralized control station and the local manual control.
- ii) The transfer of propulsion control between the navigation bridge and the propulsion machinery space is to be possible only in the propulsion machinery space (i.e., at either the centralized control station or the local manual control position).
- iii) The centralized control station is to be capable of assuming propulsion control at any time or blocking orders from other remote control stations. However, where special operating requirements of the vessel prevail, override control over the centralized control station will be considered.
- iv) Propeller speed and direction of thrust are to be prevented from altering significantly when propulsion control is transferred from one control station to another.

13.13 Local Manual Control

Means are to be provided for local manual control so that satisfactory operation of the propulsion machinery can be exercised for lengthy periods in the event of the failure of the remote propulsion control system. For this purpose, indicators for propeller speed and direction of rotation (for fixed pitch propellers) or pitch position (for controllable pitch propellers) are to be provided at this local manual control station. The means of communication, as required by 4-8-2/11.5, is to be fitted also at this manual control station.

It is also to be possible to control auxiliary machinery, which are essential for propulsion and safety of the vessel, at or near the machinery concerned.

13.15 Communications Systems

For communication systems associated with propulsion control stations, the requirements in 4-8-2/11.5 are applicable.

15 Remote Propulsion Control Station Other than Navigation Bridge

15.1 General

Where the remote propulsion control station is provided at a location other than the navigation bridge, such station is to comply with requirements applicable to that at the navigation bridge, with the exception of the provision of telegraph.

15.3 Propulsion Machinery Space

Remote propulsion control stations fitted in vessels having the propulsion machinery space manned are to be provided with the alarms, displays and controls as listed in 4-9-2/Table 2, items A1 through C2 as a minimum.

Where a remote propulsion control station is provided in or in the vicinity of the propulsion machinery space for the purpose of full remote operation of a locally manned propulsion machinery space, such a station is to be fitted with:

- Remote propulsion control station, as in 4-9-2/15.1
- Alarms, displays and controls, as required in 4-9-5/Table 1
- Alarms and displays of 4-9-6/Table 1A through 4-9-6/Table 6A, as applicable

TABLE 2
Instrumentation and Controllers on Remote Propulsion Control Stations

System	Monitored/Controlled Parameter		Notes			
			A	D	C	
					[A= Alarm; D= Display; C= Controller/Actuator] [x= applies]	
Propulsion control & monitoring	A1	Propeller speed		x	x	
	A2	Propeller direction		x	x	
	A3	Propeller pitch		x	x	As applicable
	A4	Telegraph		x	x	Not applicable to certain vessels < 500 GT, see 4-8-2/11.5.2
	A5	Emergency shutdown of propulsion engine			x	To be protected from accidental tripping
	A6	Starting of propulsion engine			x	For reversible engines only
	A7	Stored starting energy level – low	x	x		For reversible engines and engines fitted with means of starting at remote control station
	A8	Inhibition of starting of propulsion engine	x			Where remote engine starting is fitted
	A9	Automatic shutdown activated	x			
	A10	Automatic slowdown activated	x			If provided
	A11	Safety system override	x	x	x	If fitted (see 4-9-2/9.5). To be of a design that cannot be left activated
	A12	Shaft turning gear engaged		x		To automatically inhibit starting of engine
	A13	Operating in barred speed range	x			
	A14	Threshold warning for safety system activations	x			For navigation bridge only (see 4-9-2/9.5.2(b)).
System monitoring	B1	Power source – fails	x	x		For non- ACC vessels, the failure alarm is applicable to main power source only. For ACC vessels, applicable to main and emergency power sources. See 4-9-5/3.5.
	B2	Individual power supply to control, monitoring and safety systems – fails	x	x		Alarm may be common. See 4-2-1/7.3.3i) for main power supply failure alarm for governor control system (no display is required)
	B3	Alarm system – disconnected		x		
	B4	Integrated computer-based system: data highway abnormal conditions	x			Alarm is to be activated before critical data overload.
	B5	Integrated computer-based system: duplicated data link – failure of one link	x			
Others	C1	Control station transfer		x	x	Display: to indicate the station in control. Control: to provide 1) transfer switch & 2) acknowledgment switch.
	C2	Air conditioning system – fails	x			If necessary for equipment environment control

TABLE 2 (continued)
Instrumentation and Controllers on Remote Propulsion Control Stations

<i>System</i>	<i>Monitored/Controlled Parameter</i>	<i>A</i>	<i>D</i>	<i>C</i>	<i>Notes</i> [A= Alarm; D= Display; C= Controller/Actuator] [x= applies]	
Additional requirements for Navigation Bridge for vessels assigned with ACCU, ABCU						
ACCU, ABCU	D1	Summary alarms – activated by alarm conditions in 4-9-5/Table 2 and 4-9-6/Table 1A through 4-9-6/Table 6.	x			
	D2	High voltage rotating machine – Stationary windings temperature – high	x			4-8-5/3.7.3(c)
	D3	Controllable pitch propeller hydraulic power unit run/start/stop		x	x	If standby unit is provided with automatic starting, such starting is to be alarmed.
	D4	Steam turbine automatic shaft rollover – activated		x	x	Control: to deactivate automatic shaft rollover.
	D5	Steam turbine shaft stopped – in excess of set period	x			
	D6	Boiler steam pressure – low	x			For propulsion and associated electric power generating machinery
	D7	Boiler control power – failure	x			For propulsion and associated electric power generating machinery
	D8	System power source: main and emergency feeder – status and failure	x	x		
	D9	Propulsion machinery space – fire detected	x			
	D10	Start main fire pump and pressurize fire main		x	x	4-7-3/1.5.5
	D11	Propulsion machinery space – bilge level high	x			
	D12	Start/stop and transfer switches			x	For ABCU vessels having non-integrated propulsion machinery

Display = display of the analog or digital signal for the monitored parameter. The display of the signal is to provide indication of the monitored parameter in engineering units (such as degrees, PSI, RPM, etc.) or status indication. The engineering unit is to effectively display the relevant information concerning the monitored parameter. An alternative engineering unit which provides equivalent effectiveness, may be considered.

4

CHAPTER 9 Automation

SECTION 3 Computer-based Systems

1 Application (1 July 2018)

Computer based systems where used for control, monitoring safety or internal communication systems are to comply with the provisions of Section 4-9-3, and are subject to the classification requirements regardless of **ACC**, **ACCU** or **ABCU** notation. See 4-9-1/7.3.9 for plans and data to be submitted for review. **Navigation systems and Radio-communication systems required by SOLAS Chapters IV and V and vessel loading instrument/stability computer are not in the scope of this Section.**

3 Definitions

3.1 Programmable Electronic System (PES)

A Programmable Electronic System is a system based on one or more programmable electronic devices, connected to (and including) input devices (e.g., sensors) and/or output devices/final elements (e.g., actuators), for the purposes of control, protection or monitoring. The term “PES” includes all elements in the system, including power supplies, extending from sensors or other input devices, via data highways or other communicating paths, to the actuators, or other output devices, associated software, peripherals and interfaces.

3.3 Interface

A transfer point at which information is exchanged. Examples of interfaces include: input/output interface (for interconnection with sensors and actuators); communications interface (to enable serial communications/networking with other computers or peripherals).

3.5 Peripheral

A device performing an auxiliary function in the system (e.g., printer, data storage device).

3.7 Software Module (1 July 2018)

A *Software Module* is a **standalone** group of program or code intended to accomplish a function.

3.9 Basic Software

Basic Software is software such as operating systems or other such software supporting application software for multiple functions (i.e., middleware or firmware), which enables:

- i) Running several modules under allocated priorities;
- ii) Detection of execution failures of individual modules;
- iii) Discrimination of faulty modules to allow for maintained operation of modules at least of the same or of a higher priority.

3.11 Application Software

Application Software is ship specific software to accomplish specific tasks other than just running the computer system and supported by the basic software.

3.13 Communication Node

A communication node is a point of interconnection to a data communication link.

3.15 Task Prioritization

Task prioritization is where individual application software modules allocated as tasks under an operating system as specified in 4-9-3/3.9 are not set up to perform operations related to more than one function. Tasks are assigned priorities appropriate to the functions served.

3.17 Other Terminology (1 July 2018)

See Definitions in 4-9-3A2/3.

5 Systems Requirements

5.1 General Requirements

5.1.1 System Security (1 July 2018)

Programmable electronic systems are to be provided with effective physical and/or logical security arrangements to prevent unintentional or unauthorized access to functions or alteration of configuration, programs or data by unauthorized personnel (see 4-9-3A2/19).

Alteration of parameters that may affect the system's performance are to be limited to authorized personnel by means of keyswitch, keycard, password or other approved methods.

5.1.2 Program and Memory Data

To preclude the possible loss or corruption of data as a result of power disruption, programs and associated memory data considered to be essential for the operation of the specific system are to be stored in non-volatile memory or a volatile memory with a secure uninterruptible power supply (UPS).

5.1.3 Start-up After Power Failure

The system's software and hardware is to be designed so that upon restoration of power supply after power failure, automatic or remote control and monitoring capabilities can immediately be available after the pre-established computer control access (sign-in) procedure has been completed.

5.1.4 Self-Monitoring

5.1.4(a) Function. Computer-based systems are to be self-monitoring and any incorrect operation or abnormal condition is to be alarmed at the computer workstation.

5.1.4(b) Temperature. The processing hardware (CPU, microprocessor etc.) of computer-based systems is to be designed to operate satisfactorily at an ambient temperature of 55°C (131°F), preferably without forced ventilation.

Where forced ventilation is necessary, an alarm warning of high temperature in the processing hardware is to be given.

5.1.5 Power Supply

The power supply is to be monitored for voltage failure and protected for short circuit. Where redundant computer systems are provided to satisfy 4-9-3/5.1.6, they are to be separately fed.

5.1.6 System Independence

Control, monitoring and safety systems are to be arranged such that a single failure or malfunction of the computer equipment will not affect more than one of these system functions. This is to be achieved by dedicated equipment for each of these functions within a single system, or by the provision of redundancy, or by other suitable means considered not less effective.

5.1.7 Response Time

Computer system's memory is to be of sufficient capacity to handle the operation of all computer programs as configured in the computer system. The time response for processing and transmitting data is to be such that an undesirable chain of events may not arise as a result of unacceptable data delay or response time during the computer system's worst data overload operating condition. For propulsion related system applications, the time limit on response delays for safety and alarm displays is not to exceed two (2) seconds. (The response delay is to be taken as the time between detection of an alarm or safety critical condition and the display of the alarm or actuation of the safety system.)

5.1.8 Fail-safe

Computer-based system is to be designed such that failure of any of the system's components will not cause unsafe operation of the process or the equipment it controls. Hardware and software serving vital and non-vital systems are to be arranged to give priority to vital systems.

5.1.9 Modifications

Any significant modification to the software or hardware for system category II and III is to be submitted for approval. In addition, modifications of parameters for system Category III by the manufacturer are to be approved by ABS. Any modifications made after a performance test witnessed by the Surveyor as per item 3.5, 3.6, and 3.7 of 4-9-3/Table 2 are to be documented and traceable. See also 4-9-3/5.1.1.

Note: A significant modification is a modification which influences the functionality and/or safety of the system.

5.1.10 Emergency Stops

Emergency stops, where required, are to be hard-wired and independent of any computer-based system.

5.3 FMEA

5.3.1 General Requirements (1 July 2018)

FMEA is to be used to determine that any component failure will not result in the complete loss of control, the unsafe shutdown of the process or equipment, or other undesirable consequences (see 4-9-3A2/7).

7 Systems Configuration (1 July 2018)

7.1 System Categories

Computer-based systems subject to classification requirements are to be assigned into the appropriate system category (I, II or III) according to the possible extent of the damage that may be caused by a single failure within the computer-based systems and the effect on system functionality, as shown in 4-9-3/Table 1.

TABLE 1
System Categories (1 July 2018)

<i>System Category</i>	<i>Effects of Failure</i>	<i>Typical System Functionality</i>
I	Failure will not lead to dangerous situations for human safety, safety of the vessel and/or threat to the environment.	Monitoring function for informational/administrative tasks
II	Failure could eventually lead to dangerous situations for human safety, safety of the vessel and/or threat to the environment.	Alarm and monitoring functions Control functions which are necessary to maintain the ship in its normal operational and habitable conditions
III	Failure could immediately lead to dangerous situations for human safety, safety of the vessel and/or threat to the environment.	Control functions for maintaining the vessel's propulsion and steering Vessel safety functions

7.3 Examples

Examples of assignment to system categories are shown in 4-9-3A2/5 but are not exhaustive.

9 Software

9.1 General Principle (1 July 2018)

The computer-based systems software design is to follow the Software Development Life Cycle (SDLC), a global top to bottom approach regarding software and the integration in a system, spanning the software lifecycle: from concept generation to design, development, verification & validation and final delivery. SDLC can be defined as the framework that describes the activities and deliverables performed at each stage of a software development project.

9.3 SDLC (1 July 2018)

**FIGURE 1
V-Model for SDLC**

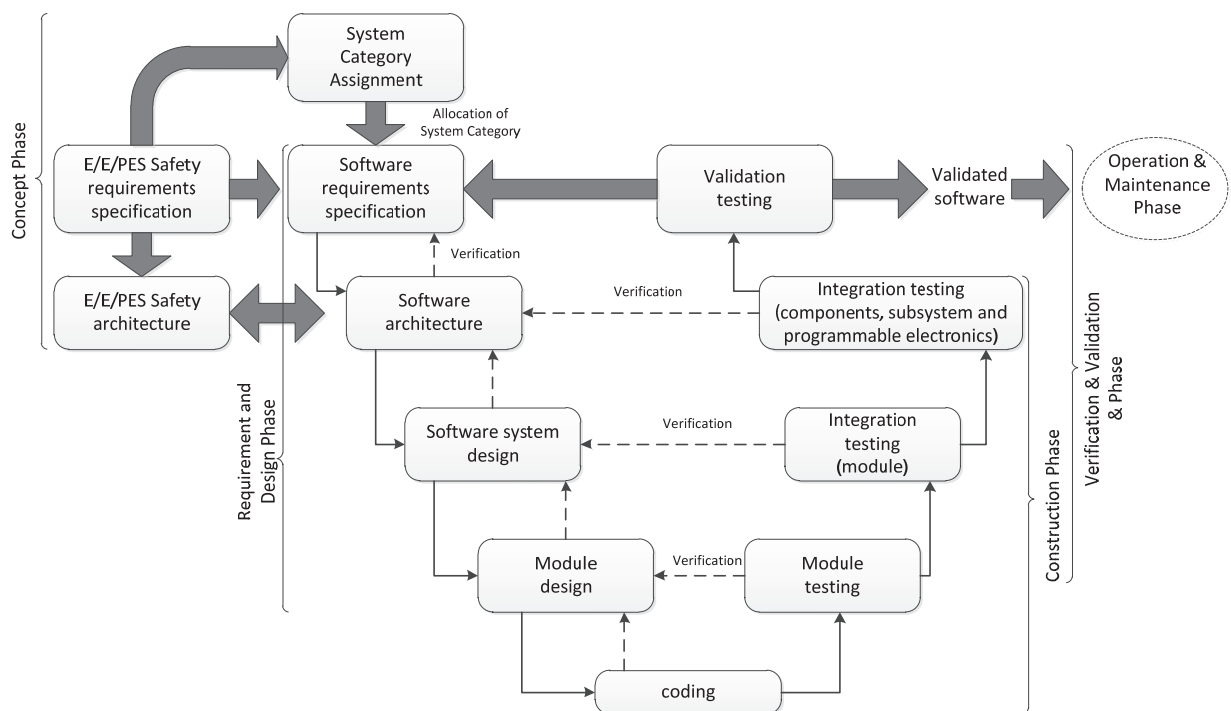

The Software Development Life Cycle (SDLC) covers the entire life of software development from concept to decommission of the computer-based system. The software development process can be represented by a life cycle model consisting of several stages. The modified system-categorized based V-Model of SDLC is shown in 4-9-3/Figure 1 where the original SDLC V-Model is from IEC 61508-3 (2010-04), *Functional safety of electrical/electronic/programmable electronic safety-related systems – Part 3: Software requirements*. The modified SDLC V-Model is comprised of a sequence of stages that overlap and are iterative. See 4-9-3A2/1 for industry standards that can be used for the development of hardware/software of computer based systems.

9.3.1 Concept Phase

The Concept Phase is the first stage among the SDLC which provides the direction, scope and overall picture of the computer-based system software development. The goals and objectives of the system are to be defined as well as strategies, tactics, policies, and constraints affecting the system.

The system category following the criteria in 4-9-3/7.1 is to be assessed and assigned to the computer-based system during this phase.

The main goal of this phase is to clearly define the requirements in the following aspects, as applicable:

- i) Quality plan for software
- ii) Analysis regarding existence and fulfillment of programming procedures for safety related functions

9.3.2 Requirement and Design Phase (1 July 2018)

Requirement and Design Phase is to focus on the software requirements specification, software architecture, system design and module design. During this phase, the requirements and detailed specification of all the software functions are developed, modeled and documented from Concept Phase.

The main goal of this phase is to produce the following two categories of requirements specification, either Software Requirements Specification (SRS) & Software Design Specification (SDS) or Functional Description Document (FDD).

- i) *Software Requirements Specification (SRS)*. The SRS is to specify the requirements for a software item and the methods to be used to ensure that each requirement has been met. It is used as the basis for design and qualification testing of a software item.
- ii) *Software Design Specification (SDS)*. The SDS is to describe the design of the computer-based system software. Typical contents include software architecture, control logic, data structures, input/output formats, interface descriptions, and algorithms.

OR

- iii) *Functional Description Document (FDD)*. The FDD describes the capabilities and functions that a computer-based system must be able to perform successfully. This document may be called a Functional Design Specification (FDS), Technical Description Document DCO's manual, etc., by different organizations.

At the end of this phase, failure analysis for safety related functions only is to be performed based on the system category assignment.

See 4-9-3A2/9.

At the end of this phase, failure analysis for safety related functions only is to be performed based on the system category assignment. See 4-9-3A2/7.

9.3.3 Construction Phase

Construction Phase consists of coding of the Software Modules, the SRS and SDS refinement, module test, subsystem test, system test, and integration test, etc. The major goal of this phase is to translate all the requirements specification to real software code. The program is built or coded during this phase. The software coding and testing are the major activities in this phase.

9.3.4 Verification and Validation (V&V) Phase

In V&V Phase the software program is verified to the FDD or SRS & SDS. This process is iterative and regressive to detect any new defect introduced by the correction of a previously detected and corrected defect(s). Closed loop testing, Software-in-the-loop and Hardware-in-the-loop are some of the recognized methodologies.

The computer-based system is validated during commission and sea trials and with a review of the system's performance compared against the functional requirement in Concept Phase. Interactions of hardware and software components are to be considered when testing the software in the V&V Plan.

The system testing plan is to be specified and submitted before the hardware and software test will be carried out. The testing plan is to at least include test schedule, test levels according to different system categories and test cases.

Verification is when the software is tested using a specification. Validation is when the user states that the computer-based system meets their expectations.

9.3.4(a) *Test Program*. Tests are to be carried out, and the evidence of quality assurance is to be maintained in accordance with 4-9-3/Table 2.

Where the Surveyor's witness is required in accordance with 4-9-3/11.9 and 4-9-3/9.3.4(b), the test procedure for hardware test and performance test for computer-based system of Category II and III is to be submitted for review. For these computer-based systems, the test procedure is to include the tests in 4-9-9/Table 2 and the required functions in Section 4-9-3 for verification.

9.3.4(b) *Performance Test.* For a computer-based system of Category II and III associated with a specific class notation (e.g., **ACC**, **ACCU**, **ABCU**, **DPS**, etc.), a performance test is to be witnessed by the Surveyor in accordance with item 3.5, 3.6, and 3.7 of 4-9-3/Table 2.

The performance test is not required to be witnessed by the Surveyor for computer-based systems of Category II, which are not associated with a specific class notation. However, the performance test is to be witnessed by the Surveyor for computer-based systems of Category III. The manufacturer is required to submit the performance test report to ABS regardless of the system category, when requested.

9.3.5 Operation and Maintenance Phase

Operation and Maintenance (O & M) Phase cover all operational and maintenance activities including scheduled and unscheduled upgrades and problem resolution activities. An O & M plan is to be prepared and to define a systematic and documented approach to the application software maintenance.

All the maintenance activities including software modification and upgrade are to be documented. Software modifications and upgrades for Category II and III computer-based system are to be submitted to ABS for review. The O & M plan extends to the requirement activities of the control system with replacement or recycling the hardware.

9.5 Software Documentation and Testing

All the tests and documentation associated with SDLC are shown in 4-9-3/Table 2. The required tests and documentation are based on the system category of the computer-based system. The detailed descriptions of the contents are shown in Appendix 4-9-3A1.

TABLE 2
SDLC Tests and Documentation (1 July 2018)

SDLC Phases	Item No.	Documentation	System Category		
			I	II	III
Concept Phase	1.1	Quality plan for software		S/M	S/M
	1.2	Analysis regarding existence and fulfillment of programming procedures for safety related functions			S
Requirement & Design Phase	2.1a	Software Requirements Specification (SRS)		M	M
	2.1b	Software Design Specification (SDS)		M	M
	2.2	Functional Description Document (FDD)		M	M
	2.3	Software Description		M	S
	2.4	Failure analysis for safety related functions only	M	M	S
Construction Phase	3.1	Quality control in production		M	M
	3.2	Module tests		M	S
	3.3	Subsystem tests		M	S
	3.4	System test		M	S
	3.5	Integration test		M	W
	3.6	Fault simulation		W	W
	3.7	Factory Acceptance Test	M	W	W
	3.8	Final test reports	M	M	S
	3.9	Evidence of software testing according to quality plan		M	S

TABLE 2 (continued)
SDLC Tests and Documentation (1 July 2018)

SDLC Phases	Item No.	Documentation	System Category		
			M	W	S
Verification & Validation Phase	4.1	On-board complete system test	M	W	W
	4.2	On-board integration test		W	W
	4.3	Traceability of software	M	M	S
Operation & Maintenance Phase	5.1	Operation & Maintenance Plan		M	M
	5.2	Software Version Record	M	S/W	S/W
	5.3	Software Modification and Upgrades Record	M	M	M
	5.4	Test after modifications	M	S/W	S/W

Notes:

- 1 M = Evidence kept by manufacturer and upon request checked by ABS.
- 2 S = Evidence to be checked by ABS.
- 3 W = To be witnessed by the Surveyor.
- 4 All evidence may be subject to review and therefore, upon request, is to be submitted for review.
- 5 Definitions and notes relating to 4-9-3/Table 2 are given in Appendix 4-9-3A1.
- 6 System categories are defined in 4-9-3/Table 1.
- 7 Tests after modifications for Category II and III depend on the level of modification and subject to ABS review Engineers' judgment, whether the tests need to be witnessed by surveyors.
- 8 In 'Requirement and Design Phase', either FDD or SRS & SDS are to be submitted if required according to the system category, If the software is already a production software, FDD can replace SRS or SDS document.

11 Hardware

11.1 Design for Ease of Maintenance

The design and layout of the hardware is to ensure ease of access to interchangeable parts for repairs and maintenance. Each replaceable part is to be simple to replace and is to be constructed for easy and safe handling. All replaceable parts are to be so designed that it is not possible to connect them incorrectly or to use incorrect replacements. Where this is not practicable, the replaceable parts and their mounting location, including their means of electrical connection, are to be clearly marked.

11.3 User Interface and Input Devices

11.3.1 General

Input devices are to have clearly marked functions and, as far as practicable, are to be arranged to avoid conceivable inadvertent errors in their operations.

11.3.2 Security

Input devices, such as keyboard, which can be used to effect changes to equipment or processes under control, are to be provided with security arrangement, such as password, so as to limit access to authorized personnel only.

Where a single action of, for example, pressing of a key is able to cause dangerous operating conditions or malfunctions, measures such as use of two or more keys are to be taken to prevent execution by a single action.

11.3.3 Control Status

Where control action can be effected from more than one station, conflicting control station actions are to be prevented by means of interlock or warning. Control status is to be indicated at all stations.

11.5 Visual Display Unit

11.5.1 General

The size, color and density of text and graphic information displayed on a visual display unit are to be such that it may be easily read from the normal operator position under all operational lighting conditions. The brightness and contrast are to be capable of being adjusted.

11.5.2 Alarm Display

Where alarms are displayed by means of visual display unit, they are to appear in the sequence as the incoming signals are received. Alarming of the incoming fault signals is to appear on the screen, regardless of the mode the computer or the visual display unit is in.

11.5.3 Propulsion Monitoring

Where a computer is used as the operator interface to display monitoring parameters, the centralized control station is to be provided with at least two computers, including keyboards and monitors, unless other means of display are provided capable of displaying the same information.

11.5.4 Color Monitor

The failure of a primary color is not to prevent an alarm from being distinctly indicated.

11.7 Graphical Display

11.7.1 General

Information is to be presented clearly and intelligibly, according to its functional relations. Display presentations are to be restricted to the data which is directly relevant for the user.

11.7.2 Alarms

Alarms are to be clearly distinguishable from other information and are to be visually and audibly presented with priority over other information, regardless of the mode the computer or the visual display unit is in.

11.9 Hardware Documentation and Testing

All computer hardware of module, sub-system or system level in Category II or III subject to classification requirements are to be qualified in accordance with Section 4-9-9, except for printer, data recording, logging device or similar.

Type tests according to 4-9-9/Table 1 and Surveyor's witness for the tests in 4-9-9/13.1i), ii) and iii) are to be carried out for the computer hardware associated with notations **ACC, ACCU, ABCU, DPS**, etc.

Surveyor's witness in 4-9-9/13 is not required for the computer hardware that is not associated with a specific class notation (e.g., **ACC, ACCU, ABCU, DPS**, etc.). In this case, the test report witnessed and approved by another IACS Member Society for compliance with 4-9-9/Table 1 (or IACS UR E10) is acceptable.

4-9-3/Table 3 shows the hardware related tests and documentation.

TABLE 3
Tests and Documentation

Item No.	Tests and Evidence	System Category		
		I	II	III
1	Inspection of components (only Hardware) from sub-suppliers		M	M
2	Hardware description		M	S
3	Type tests according to 4-9-9/Table 1		W	W
4	Wireless Data Communication Test	W	W	W

13 Data Communication

13.1 Data Communication

13.1.1 Data Communication Network

13.1.1(a) General. The requirements in 4-9-3/13.1 are applicable to the system of Category II and III using shared data communication network to transfer data between distributed programmable electronic equipment or systems.

13.1.1(b) Monitoring of the Network. The data communication network is to be continuously monitored to detect failures on the communication network itself and data communication failure on nodes connected to the network. Any detected abnormal condition is to be alarmed at the centralized control station and on the navigation bridge.

13.1.1(c) Prevention of Overloading. Safeguards are to be provided to prevent unacceptable data transmission delays (overloading of network). Alarm is to be activated prior to a critical data overload condition.

13.1.1(d) Integrity of Data. Means are to be provided to ensure the integrity of data and provide timely recovery of corrupted or invalid data.

13.1.2 Duplicated Data Communication Network

13.1.2(a) Duplication of the Network. When the same data communication network is used for two or more essential functions (e.g., propulsion control and generator control), this network is to be duplicated, and each is to be routed as far apart from the other as practical. The duplicate network is for standby purpose only and not to be used to reduce traffic in the online network.

13.1.2(b) Monitoring of the Network. Duplicated data communication network is to be arranged so that upon the failure of the online network, the standby network is automatically connected to the system. Switching between duplicated networks is not to disturb data communication or continuous functioning of the system. The failure of one network is to be alarmed at the centralized control station and on the navigation bridge.

13.1.3 Connection Failure

A complete failure in connectivity between component systems and the data highway is not to affect individual functionality of the component systems.

Where a single component failure results in loss of data communication, means are to be provided to automatically restore data communication.

Loss of a data communication network is not to affect the ability to operate essential services by alternate means.

13.3 Wireless Data Communication

Wireless data communication will be specially considered depending upon the purpose.

13.3.1 Non-essential and Recreational Purposes, Entirely Within the Living Accommodations

Wireless data communication used for non-essential and recreational purposes, entirely within the living accommodations, will be specially considered provided it is demonstrated that there is no detrimental effect on essential services. Further documentation is to be submitted for review which demonstrates compliance with 4-9-3/13.3.3(c), 4-9-3/13.3.3(e) and 4-9-3/13.3.3(f).

13.3.2 Non-essential and Recreational Purposes

Wireless data communication used for non-essential and recreational purposes, within the living accommodations and outside of the living accommodations, will be specially considered provided there is no detrimental effect on essential services. Further documentation is to be submitted for review which demonstrates compliance with 4-9-3/13.3.3(a) through 4-9-3/13.3.3(f).

13.3.3 Vessel Services (Non-Recreational Purposes)

Wireless data communication used for vessel services (such as essential services, category I systems, category II systems, category III systems, etc.) will be specially considered provided the use of the wireless data communications results in an improvement in the safety of the vessel, compared to wired data communication. Documentation which demonstrates an improvement in safety is to be submitted for review. Further documentation is to be submitted for review which demonstrates compliance with 4-9-3/13.3.3(a) through 4-9-3/13.3.3(f).

Note: For assignment of system categories, see 4-9-3/7.1. Since a failure of a category I system should not lead to a dangerous situation and failure of a category II system could eventually lead to a dangerous situation, an improvement in the safety of the vessel will be more difficult to demonstrate for wireless data communication used in category II system, compared to category I systems. Since a failure of a category III system may immediately lead to an accident with catastrophic severity, wireless systems and equipment are unlikely to be permitted in category III systems.

13.3.3(a) Risk Analysis. A suitable risk analysis (such as an Failure Modes and Effects Analysis (FMEA)) is to be performed which demonstrates that an interruption or failure in the wireless data communication will not lead to a hazardous situation.

Note: Consideration is to be given to the possibility of corrupted data and intermittent failures with comparatively long recovery times between interruptions.

13.3.3(b) Type Testing. The wireless equipment is to meet the environmental type testing requirements of 4-9-9/13.1 and 4-9-9/Table 1 based on the proposed location of installation.

13.3.3(c) Wireless Data Communication Tests. The wireless data communication is to not cause interference with any vessel systems. This is applicable to all wireless data communication equipment (even wireless data communication equipment for non-essential services). See the tests required by 4-9-3A1/13.

13.3.3(d) Wireless Data Communication Network. The wireless data communication network is to meeting the requirements of 4-9-3/5.3.2, 4-9-3/13.1.1, 4-9-3/13.1.2 and 4-9-3/13.1.3.

13.3.3(e) Wireless System Protocols. Wireless data communication is to follow recognized international wireless system protocols that incorporate the following.

- i) Message integrity.* Fault prevention, detection, diagnosis and correction so that the received message is not corrupted or altered when compared to the transmitted message.
- ii) Configuration and device authentication.* Only devices that are included in the wireless system are to be permitted to connect to the wireless system.
- iii) Message encryption.* Protection of the confidentiality and criticality of the data content.
- iv) Security management.* Protection of network assets, prevention of unauthorized access to network assets.

13.3.3(f) Radio-Frequency and Power Level. The wireless system is to comply with the radio-frequency and power level requirements of the International Telecommunications Union and flag state requirements.

Note: Consideration is to be given to system operation in the event of port state and local requirements that pertain to the use of radio-frequency transmission prohibiting the operation of a wireless data communication system due to radio-frequency and power level restrictions.

13.3.3(g) Alternative Means of Control. Functions that are required to operate continuously to provide essential services dependent on wireless data communication are to be provided with an alternative means of control that can be brought into action within an acceptable period of time.

4

CHAPTER 9 Automation

SECTION 3 Appendix 1 – Definitions and Notes Relating to SDLC and Hardware Test and Evidence Documentation in 4-9-3/Tables 2 and 3

1 Concept Phase

1.1 **Quality Plan for Software** (1 July 2018)

A plan for software lifecycle activities is to be produced which defines relevant procedures, responsibilities and system documentation, including configuration management **and as a minimum, all of material required in 4-9-3A2/23.**

1.3 **Analysis Regarding Existence and Fulfillment of Programming Procedures for Safety Related Functions**

Specific assurance methods are to be planned for verification and validation of satisfaction of requirements:

- Diverse programs
- Program analysis and testing to detect formal errors and discrepancies to the description
- Simple structure

3 Requirements & Design Phase

3.1 **Software Requirements Specification (SRS)** (1 July 2018)

The SRS is to address the following information, at a minimum, recommended in IEEE 830 – *IEEE Recommended Practice for Software Requirements Specifications* (See 4-9-3A2/1 for alternative standards):

- *Functionality.* What is the software supposed to do?
- *External Interfaces.* How does the software interact with personnel, the system's hardware, other hardware, and other software?
- *Performance.* What is the speed, availability, response time, recovery time of various software functions, etc.?
- *Attributes.* What are the reusability, correctness, maintainability, security, etc., considerations?
- *Design Constraints.* What constraints are imposed on this implementation?
- *Other.* Are there any required standards in effect, implementation language, policies for database integrity, resource limits, operating environment(s), etc.?

3.3 **Software Design Specification (SDS)** (1 July 2018)

The software detailed design is to be evaluated using these criteria recommended in the IEEE 12207.0-1996 *Standard for Information Technology – Software life cycle processes* (See 4-9-3A2/1 for alternative standards):

- Traceability to the requirements of the software item
- External consistency with the architectural design

- Internal consistency between software components (modules, programs)
- Appropriateness of design methods and standards used
- Feasibility testing
- Feasibility of operations and maintenance

3.5 Functional Description Document (FDD)

The FDD defines the capabilities and functions that a System must be able to perform successfully. It is to include the following aspects, as applicable:

- Sufficient functions descriptions
- Description of fail-safe states
- Number and description of Human Machine Interfaces
- Number and description of interfaces (data collection, SCADA systems...)

3.7 Software Description

Software is to be described:

- Description of the basic and communication software installed in each hardware unit
- Description of application software (not program listings)
- Description of functions, performance, constraints and dependencies between modules or other components

3.9 Failure Analysis for Safety Related Functions Only (For Example FMEA) (1 July 2018)

The analysis is to be carried out using appropriate means:

- Fault tree analysis
- Risk analysis
- Failure Modes and Effects Analysis (FMEA) or Failure Mode, Effects and Criticality Analysis (FMECA)

Loss of a data link is to be specifically addressed in the analysis. The purpose is to demonstrate that for single failures, systems will fail to safety and that systems in operation will not be lost or degraded beyond acceptable performance criteria for system Category III.

In addition to the above for the FMEA or FMECA requirements of the safety related functions of computer based systems, see additional FMEA or FMECA requirements of Subsection 2/11 of the ABS *Guide for Dynamic Positioning Systems* for **DPS** notation, and 4-9-1/7.3.5 and 4-9-2/3.1.1 for **ACC**, **ABCU** or **ACCU** notation.

5 Construction Phase

5.1 Quality Control in Production (1 July 2018)

Evidence of quality assurance measures on production. See 4-9-3A2/23.

5.3 Module Tests

Software module tests are to provide evidence that each module performs its intended function and does not perform unintended functions.

5.5 Subsystem Tests

Subsystem testing is to verify that modules interact correctly to perform the intended functions and do not perform unintended functions.

5.7 System Tests

System testing is to verify that subsystems interact correctly to perform the functions in accordance with specified requirements and do not perform unintended functions.

5.9 Integration Tests (1 July 2018)

Integration testing for computer-based systems is to be carried out using satisfactorily tested system software, and as far as practicable intended system components to verify correct functionality has been achieved. See 4-9-3A2/11.

5.11 Fault Simulation (1 July 2018)

Faults are to be simulated as realistically as possible to demonstrate appropriate system fault detection and system response. The results of any required failure analysis are to be observed. See 4-9-3A2/11.

5.13 Factory Acceptance Test (FAT)

Factory acceptance testing is to be carried out in accordance with a test program. Testing is to be based on demonstrating that the computer-based system fulfills the requirements specified in Section 4-9-6.

5.15 Final Test Reports

Reports from testing of the finished product and documentation of the test results.

5.17 Evidence of Software Testing According to Quality Plan (1 July 2018)

Procedures for verification and validation activities are to be established:

- Methods of testing
- Test programs producing
- Simulation

See 4-9-3A2/9.

7 Verification & Validation Phase

7.1 Complete System Test (1 July 2018)

Testing is to be performed on the completed system comprising actual hardware components with the final application software, in accordance with an approved test program. See 4-9-3A2/15.

7.3 Onboard Integration Tests (1 July 2018)

Onboard testing is to verify that correct functionality has been achieved with all systems integrated. See 4-9-3A2/15.

7.5 Traceability of Software

Modification of program contents and data, as well as change of version, has to be carried out in accordance with a procedure and is to be documented.

9 Operation & Maintenance Phase

9.1 Operation & Maintenance Plan

The O&M Plan is to include the following items, as applicable:

- The plan is to define what constitutes operation and maintenance.
- The plan is to define where operation and maintenance occur (e.g., on the asset, in a shipyard, at the vendors manufacturing facility, remotely via a manufacturers' asset network access).

- The plan is to define when specific operations and maintenance occur; (e.g., scheduled testing of BOP equipment, replacement of obsolete PLCs, and preventative maintenance schedules for all equipment).
- The plan is to describe the operation and maintenance activities to be performed (e.g., preventative maintenance procedures, expendable goods replacement, software backup and restore).
- The plan is to address system testing and configuration documentation updates following configuration changes, repairs, and upgrades.
- The plan is to address expected life and end-of-life replacement, upgrade and retirement.

9.3 Software Version Record

Software versions are to be uniquely identified. It can be identified by number, date or other appropriate means. Software version control is to be established through software configuration management system.

A revision history is to be documented for the software function that includes the data and a description of the change. The document is to be available for surveyor check.

9.5 Software Modification and Upgrades Record (1 July 2018)

Any software modification is to be made evident by changing the relevant version identifier and is to be documented by the manufacturer. Subsequent significant modifications to the software and hardware for system categories II and III are to be submitted for approval.

Note: A significant modification is a modification which influences the functionality and/or safety of the system.

Additional documentation may be required for systems of category III. The documentation is to include a description of the methods of test and required test results.

Software upgrades are to be recorded and kept on board for Surveyor to check. See 4-9-3A2/17.

9.7 Tests After Modifications

Modifications to approved systems are to be notified in advance.

Regression test is recommended to be used to test the “modified” software for new defects that may have been introduced during the coding to correct a previously known or detected defect. Regression test is to include complete testing of all inputs to and outputs from the changed software module that interfaces with Category II or Category III system.

11 Hardware Documentation and Testing

11.1 Hardware Description

Hardware is to be described.

- System block diagram, showing the arrangement, input and output devices and interconnections
- Connection diagrams
- Details of input and output devices
- Details of power supplies

11.3 Inspection of Components (Only Hardware) from Sub-suppliers

Proof that components and/or sub-assemblies conform to specification.

11.5 Type Tests

Type tests according to 4-9-9/Table 1.

Special consideration may be given to tests witnessed and approved by another IACS member society. See 4-9-3/11.9.

13 Wireless Data Communication Tests

Tests during harbor and sea trials are to be conducted to demonstrate that radio-frequency transmission from wireless data communication equipment does not cause failure of any equipment and does not cause the wireless data communication equipment itself to fail as a result of electromagnetic interference during expected operating conditions.

Notes:

- 1 Where electromagnetic interference caused by wireless data communication equipment is found to be causing failure of equipment or systems, the layout and/or equipment is to be changed to prevent further failures from occurring.
- 2 In the unlikely case when wireless data communication is permitted in systems of category III, the level of witnessing will be determined during review. The scope of the testing for systems of category III will be more extensive than for systems of category II.

PART

4

CHAPTER 9 Automation

SECTION 3 Appendix 2 – On Board Use and Application of Computer-based Systems (1 July 2018)

1 References

The following identified standards can be used for the development of hardware/software of computer-based systems. Other industry standards may be considered:

- IEC 61508: Functional safety of electrical/electronic/programmable electronic safety-related systems
- ISO/IEC 12207: Systems and software engineering – Software life cycle processes
- ISO 9001:2008 Quality Management Systems – Requirements
- ISO/IEC 90003: Software engineering - Guidelines for the application of ISO 9001:2008 to computer software
- IEC 60092-504: Electrical installations in ships – Part 504: Special features – Control and instrumentation
- ISO/IEC 25000: Systems and software engineering – Systems and software Quality Requirements and Evaluation (SQuaRE) - Guide to SQuaRE
- ISO/IEC 25041: Systems and software engineering – Systems and software Quality Requirements and Evaluation (SQuaRE) - Evaluation guide for developers, acquirers and independent evaluators
- IEC 61511: Functional safety – Safety instrumented systems for the process industry sector
- ISO/IEC 15288: Systems and software engineering – system life cycle process

3 Definitions

3.1 Stakeholders

3.1.1 Owner

The Owner is the party responsible for contracting the system integrator and/or suppliers to provide a hardware system including software according to the owner's specification. The Owner could be the Ship Builder Integrator (Builder or Shipyard) during initial construction. After vessel delivery, the owner may delegate some responsibilities to the vessel operating company.

3.1.2 System Integrator

The role of system integrator is to be filled by the yard unless an alternative organization is specifically contracted for or assigned this responsibility. The system integrator is responsible for the integration of systems and products provided by suppliers into the system according to the requirements specified herein and for providing the integrated system. The system integrator may also be responsible for integration of systems in the vessel.

If there are multiple parties performing system integration at any one time a single party is to be responsible for overall system integration and coordinating the integration activities. If there are multiple stages of integration different System Integrators may be responsible for specific stages of integration but a single party is to be responsible for defining and coordinating all of the stages of integration.

3.1.3 Supplier

The Supplier is any contracted or subcontracted provider of system components or software under the coordination of the System Integrator or Shipyard. The supplier is responsible for providing programmable devices, sub-systems or systems to the system integrator. The supplier provides a description of the software functionality that meets the Owner’s specification, applicable international and national standards, and the requirements specified herein.

3.3 Objects

4-9-3A2/Figure 1 shows the hierarchy and relationships of a typical computer-based system.

FIGURE 1
Typical Computer-based System (1 July 2018)

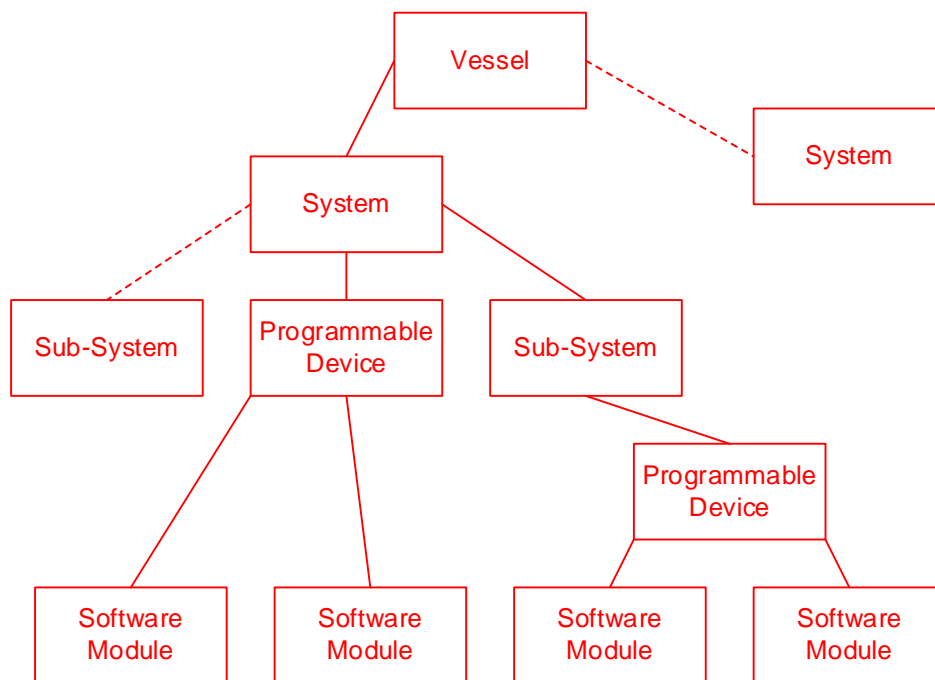

Note: Dashed lines on drawing indicate branches not yet developed.

3.3.1 Object Definitions

Vessel: Ship or offshore unit where the system is to be installed.

System: Combination of interacting programmable devices and/or sub-systems organized to perform one or more specified actions. See 4-9-3/3.1.

Sub-system: Identifiable part of a system, which may perform a specific function or set of functions.

Programmable Device: Physical component where software is installed.

Software Module: See 4-9-3/3.7.

3.5 Simulation Tests

Control system testing where the equipment under control is partly or fully replaced with simulation tools, or where parts of the communication network and lines are replaced with simulation tools.

5 System Categories

5.1 Systems Typically Belonging to Category III

- Propulsion system of a ship, meaning the means to generate and control mechanical thrust in order to move the ship (devices used only during maneuvering, such as bow tunnel thrusters, are not in the scope of this requirement)
- Steering system control system
- Electric power system (including power management system)
- Ship safety systems covering fire detection and fighting, flooding detection and fighting, internal communication systems involved in evacuation phases, ship systems involved in operation of life saving appliances equipment
- Dynamic positioning system of equipment classes 2 and 3 according to IMO MSC/Circ.645 or MSC.1/Circ.1580.
- Drilling systems

The exact category is dependent on the risk assessment for all operation scenarios.

5.3 Systems Typically Belonging to Category II

- Liquid cargo transfer control system
- Bilge level detection and associated control of pumps
- Fuel oil treatment system
- Ballast transfer valve remote control system
- Stabilization and ride control systems
- Alarm and monitoring systems for propulsion systems

The exact category is dependent on the risk assessment for all operation scenarios.

7 Risk Assessment of the System

This step to determine the risk to the system throughout the lifecycle by identifying and evaluating the hazards associated with each function of the system. This document is to normally be submitted by the System Integrator or the Supplier, including data coming from other suppliers.

IEC/ISO31010 “Risk management – Risk assessment techniques” may be applied in order to determine method of risk assessment. The method of risk assessment is to be agreed by ABS. Based on the risk assessment, a revised system category may be called for between ABS and the system supplier.

Where the risks associated with a computer-based system are well understood, it is permissible for the risk assessment to be omitted. However, in such cases the supplier or the system integrator is to provide a justification for the omission. The justification should give consideration to:

- Manner in which the risks were discovered.
- The equivalence of the context of use of the current computer-based system and the computer-based system initially used to determine the risks.
- The adequacy of existing control measures in the current context of use.

9 Code Production and Testing

The following documentation is to be provided for Category II and III systems:

- Software modules functional description and associated hardware description for programmable devices. This is to be provided by Supplier and System Integrator
- Evidence of verification (detection and correction of software errors) for software modules, in accordance with the selected software development standard. Evidence requirements of the selected software standard might differ depending on how critical the correct operation of the software is to the function it performs (i.e., IEC 61508 has different requirements depending on SILs, similar approaches are taken by other recognized standard). This is to be supplied by the Supplier and System Integrator.
- Evidence of functional tests for programmable devices at the software module, sub-system, and system level. This is to be supplied by the Supplier via the System Integrator. Functional testing is to be designed to test the provisions of features used by the software but provided by the operating system, function libraries, customized layer of software and any set of parameters.

11 Integration Testing before Installation on Board

Intra-system integration testing is to be performed between system and sub-system software modules before being integrated on board. The objective is to confirm that software functions are properly executed, that the software and the hardware it controls interact and function properly together and that software systems react properly in case of failures. Faults are to be simulated as realistically as possible to demonstrate appropriate system fault detection and system response. The results of any required failure analysis are to be observed. Functional and failure testing can be demonstrated by simulation tests.

For Category II and III systems testing see 4-9-3/9.3.4. The following documentation is to be provided:

- Functional description of software.
- List and versions of software installed in system.
- User manual including instructions for use during software maintenance.
- List of interfaces between system and other ship systems.
- List of standards used for data links.
- Additional documentation as requested by ABS to demonstrate the adequacy of failure test case applied.

13 Approval of Programmable Devices for Category II and III

- Approval of programmable devices integrated inside a system is to be delivered to the system integrator or supplier. Approval can be granted on case by case basis, or as part of the ABS Type Approval Program (see 4-9-8/13.5).
- Limited approval: Sub-systems and programmable devices may be approved for limited applications with service restrictions by ABS when the ship system where they will be integrated is not known. In this case, requirements and additional drawings, details, tests reports and surveys related to the Standard declared by the Supplier may be required by ABS.

15 Final Integration and Onboard Testing

Simulation tests are to be undertaken before installation, when it is found necessary to check safe interaction with other computerized systems and functions that could not be tested previously.

Onboard tests are to confirmed that a computer-based system in its final environment, integrated with all other systems with which it interacts:

- Performs the functions it was designed for
- Reacts safely in case of failures originated internally or by devices external to the system
- Interact safely with other systems implemented on board vessel

For final integration and onboard testing of Category II and III systems see 4-9-3/Table 2.

17 Modifications During Operation

17.1 Responsibilities

Organizations in charge of software modifications are to be clearly declared by Owner to ABS. A System integrator is to be designated by the Owner and is to fulfil requirements mentioned in Section 4-9-3. Limited life cycle steps may be admitted for modifications already considered and accepted in the scope of initial approval.

At the vessel level, it is the responsibility of Owner to manage traceability of these modifications; the achievement of this responsibility is to be supported by system integrators updating the Software Registry. This Software Registry is to contain:

- List denoting types and versions of software installed in systems required in 4-9-3A2/11.
- Results of security scans as described in 4-9-3A2/19.

17.3 Change Management

The owner is to ensure that necessary procedures for software and hardware change management exist on board, and that any software modification/upgrade are performed according to the procedure. All changes to computer-based systems in the operational phase are to be recorded and be tracked.

19 System Security

The Owner, system integrator and suppliers are to adopt security policies and include them in their quality systems and procedures.

For Category I, II, and III systems, physical and logical security measures are to be put in place to prevent unauthorized or unintentional modification of software, whether undertaken at the physical system or remotely.

Prior to installation, all artefacts, software code, executables and the physical medium used for installation on the vessel are to be scanned for viruses and malicious software. Results of the scan are to be documented and kept with the Software Registry.

21 Requirements for Data Links for Category II and III Systems

21.1 General Requirements

- Loss of a data link is to be specifically addressed in risk assessment analysis. See 4-9-3A1/3.9.
- A single failure in data link hardware is to be responded to automatically in order to restore the proper working of system. For Category III systems a single failure in data link hardware is not to influence the proper working of the system. See 4-9-3/13.1.
- Characteristics of data link is to prevent overloading in any operational condition of system. See 4-9-3/13.1.1(c).
- The data link is to be self-checking, detecting failures on the link itself and data communication failures on nodes connected to the link. Detected failures are to initiate an alarm. See 4-9-3/13.1.

21.3 Specific Requirements for Wireless Data Links

21.3.1 Category II Systems

Category III systems are not to use wireless data links unless specifically considered by ABS on the basis of an engineering analysis carried out in accordance with an International or National Standard acceptable to the Society. See Note in 4-9-3/13.3.3.

21.3.2 Other Categories of Systems

Other categories of systems may use wireless data links with requirements in 4-9-3/13.3.3(e), 4-9-3/13.3.3(f) and 4-9-3A1/13.

23 Quality System

System integrators and suppliers are to operate a quality system regarding software development and testing and associated hardware such as ISO 9001 taking into account ISO 90003.

Satisfaction of this requirement is to be demonstrated by either the quality system being certified as compliant to the recognized standard by an organization with accreditation under a national accreditation scheme, or ABS confirming compliance to the standard through a specific assessment (see Appendix 1-1-A3 and the *ABS Guide for Integrated Software Quality Management*).

This quality system is to include:

- i) Relevant procedures regarding responsibilities, system documentation, configuration management and competent staff.
- ii) Relevant procedures regarding software lifecycle and associated hardware:
 - Organization set in place for acquisition of related hardware and software from suppliers.
 - Organization set in place for software code writing and verification.
 - Organization set in place for system validation before integration in the vessel.
- iii) Approval of quality system:
 - A specific procedure for verification of software code of Category II and III at the level of systems, sub-systems and programmable devices and modules.
 - Check points for Category II and III systems (see 4-9-3/Table 2).
 - Specific procedure for software modification and installation on board the vessel defining interactions with owners.

25 Involvement of System Supplier, System Integrator and Owner

<i>Requirement</i>	<i>Supplier Involved</i>	<i>System Integrator Involved</i>	<i>Owner Involved</i>	<i>Category I</i>	<i>Category II</i>	<i>Category III</i>
Quality Plan	X	X			See 4-9-3/Table 2 (1.1)	See 4-9-3/Table 2 (1.1)
Risk assessment report		X		See 4-9-3/Table 2 (2.4)	See 4-9-3/Table 2 (2.4)	See 4-9-3/Table 2 (2.4)
Software modules functional description and associated hardware description	X (if necessary)	X			See 4-9-3/Table 2 (2.2)	See 4-9-3/Table 2 (2.2)
Evidence of verification of software code	X (if necessary)	X			See 4-9-3A1/5.17	See 4-9-3A1/5.17

<i>Requirement</i>	<i>Supplier Involved</i>	<i>System Integrator Involved</i>	<i>Owner Involved</i>	<i>Category I</i>	<i>Category II</i>	<i>Category III</i>
Evidence of functional tests for elements included in systems of Category II and III at the level of software module, sub-system and system	X	X			See 4-9-3A1/5.17	See 4-9-3A1/5.17
Test programs and procedures for functional tests and failure tests		X			See 4-9-3/9.3.4	See 4-9-3/9.3.4
Factory acceptance test event including functional and failure tests	X	X			See 4-9-3A1/5.13	See 4-9-3A1/5.13
Test program for simulation tests for final integration		X			See 4-9-3/9.3.4	See 4-9-3/9.3.4
Simulation tests for final integration		X			See 4-9-3/Table 2 (3.7)	See 4-9-3/Table 2 (3.7)
Test program for onboard tests (includes wireless network testing)		X			See 4-9-3/9.3.4	See 4-9-3/9.3.4
Onboard integration tests (includes wireless network testing)		X			See 4-9-3/Table 2 (4.2)	See 4-9-3/Table 2 (4.2)
<ul style="list-style-type: none"> • List and versions of software installed in system • Functional description of software • User manual including instructions during software maintenance • List of interfaces between system and other ship systems 		X			See 4-9-3/Table 2 (4.3, 5.1, 5.2)	See 4-9-3/Table 2 (4.3, 5.1, 5.2)
Updated Software Registry		X	X		See 4-9-3/Table 2 (5.3)	See 4-9-3/Table 2 (5.3)
Procedures and documentation related to Security Policy					See 4-9-3/Table 2 (5.1)	See 4-9-3/Table 2 (5.1)
Test reports according to Section 4-9-8 requirements	X	X			See 4-9-3/Table 3 (3)	See 4-9-3/Table 3 (3)

See 4-9-3/Table 2.

1 Definitions

1.1 IAS

An Integrated Automation System (IAS) is a combination of computer-based systems with redundant architecture, which are interconnected in order to allow communication between computer systems; between computer systems and monitoring, control, and vessel management systems; and to allow centralized access to information and/or command/control. For example, an integrated system may consist of systems capable of performing passage execution (e.g., steering, speed control, traffic surveillance, voyage planning); machinery management and control (e.g., power management, machinery monitoring, fuel oil/lubrication oil transfer); cargo operations (e.g., cargo monitoring, inert gas generation, loading/discharging); etc.

Functions are integrated to reduce the need for hardware and software functions and to reduce interface requirements.

1.3 Module Technology

The IAS comprises different functions modules and the system can be expandable by adding more modules of different functions. The function module includes hardware module and software module. Module technology is based on the identical basic software platform, free flow of information. It reduces spare parts.

3 System Requirements

In addition to the relevant requirements in Sections 4-9-2 and 4-9-3 the following is to be complied with:

3.1 Effective Operation

Operation with an integrated automation system is to be at least as effective as it would be with individual stand-alone equipment or systems.

3.3 Integrated Automation System Failure

Failure of one part of the integrated automation system (individual module, equipment or subsystem) is to not affect the functionality of other parts, except for those functions directly dependent on the defective part.

3.5 Multi-function Displays and Controls

Where multi-function displays and controls are used, they are to be redundant and interchangeable. The number of units at control stations is to be sufficient to ensure that all functions may be provided with any one unit out of operation, taking into account any functions which are required to be continuously available

3.7 Hardware Redundancy

Common hardware in an integrated automation system serving many subsystems (e.g., monitor, keyboard, microprocessor, etc.) is to be duplicated or otherwise provided with a means of backup.

3.9 Interfaces

Standard interfaces are to be used for the data exchange between the different systems. The network is to be designed in compliance with an international standard such as IEC 61158 or IEC 61784. See also 4-9-3/13.

3.11 Control Redundancy

An alternative means of operation, independent of the integration, is to be available for all essential functions.

5 FMEA

Where the integration involves control functions for essential services or safety functions, including fire, passenger, crew, and ship safety, an FMEA is to be carried out. The FMEA is to demonstrate that the integrated system will 'fail-safe', and that essential services in operation will not be lost or degraded.

7 Documentation

Documentation is to be submitted to demonstrate that the installed integrated automation system has been designed, manufactured and tested in accordance with 4-9-1/7 and 4-9-4/3. This documentation is to be submitted by a single party responsible for the integration.

4

CHAPTER 9 Automation

SECTION 5 ACC Notation

1 Application

Where, in lieu of manning the propulsion machinery space locally, it is intended to monitor the propulsion machinery space and to control and monitor the propulsion and auxiliary machinery from a continuously manned centralized control station, such a station is to meet the provisions of 4-9-5/3. These provisions cover propulsion machinery during start-up, navigating and maneuvering, and do not cover operations in port or at mooring or anchorage.

The notation **ACC** will be assigned upon verification of compliance and upon satisfactory tests and trials carried out in accordance with the provisions of 4-9-5/9 in the presence of a Surveyor.

For purposes of assigning **ACC**, remote propulsion control from the navigation bridge is not mandatory. However, if fitted, requirements of 4-9-5/3, as applicable to navigation bridge, are to be met.

3 System Requirements

3.1 General

In general, the centralized control station is to be:

- i)* As effective as a propulsion machinery space under local supervision and operation;
- ii)* Provided with remote control of propulsion machinery;
- iii)* Provided with means to monitor the states of the propulsion machinery space, the propulsion, auxiliary and other machinery, as appropriate; and
- iv)* Provided with means to effect, manually or automatically, corrective actions, such as starting of a standby pump, in the event of a fault in the machinery plant.

3.3 System Design

In general, conceptual requirements in 4-9-2/3.1 are applicable. Specific details are provided in 4-9-5/7 through 4-9-5/15. FMEA (4-9-2/3.1.5) is to be conducted to demonstrate that control, monitoring and safety systems are so designed that any single failure will not result in the loss of propulsion control, the loss of propulsion or other undesirable consequences. The FMEA report is to be submitted for review.

3.5 System Power Supply

3.5.1 Power Source

Electrical power supply is to meet the requirements of 4-9-2/5.3. In addition, power for control, monitoring and safety systems is to be fed from two feeders, one from the main switchboard or other suitable distribution board, and the other from the emergency switchboard or an emergency distribution board. The supply status of these feeders is to be displayed and their failure is to be alarmed at the centralized control station.

3.5.2 Power Supply Transfer

The two feeders are to be connected to a transfer switch in the centralized control station. Power supply to controls, monitoring and safety systems may be commonly connected to the transfer switch. The transfer between the power supplies is to be effected automatically upon failure of a supply and by manual means at the centralized control station. Power transfer is to be achieved without a break in power supply.

5 Location of Centralized Control Station

The centralized control station is to be located within, or adjacent to, the propulsion machinery space. Consideration will be given to this station being located away from the propulsion machinery space, provided its operation and monitoring of the propulsion machinery and propulsion machinery space is to be as effective as if it were located either within or adjacent to the propulsion machinery space.

Where this station is in an enclosure located in or adjacent to machinery space, at least two means of access, separated as remote from each other as practicable, are to be provided. Where fitted, glass windows forming parts of the boundaries, are to be of shatter-resistance type (e.g., laminated glass or wire mesh embedded glass).

7 Remote Controls from Centralized Control Station

Necessary controls to operate the propulsion machinery and its associated auxiliary systems are to be provided in the centralized control station. This includes the following control functions.

- i) Remote propulsion control, as provided in Section 4-9-2
- ii) Put on-line a standby generator, as described in 4-9-5/13.9.1
- iii) Start, stop and transfer auxiliaries necessary for the operation of propulsion and power generation machinery, as described in 4-9-5/13.13

All required controls are shown in the “C” column of 4-9-5/Table 1.

9 Monitoring in Centralized Control Station

9.1 Instrumentation

Alarms and displays for monitoring propulsion and auxiliary machinery and for propulsion machinery space are to be provided in the centralized control station, as specified in “A” and “D” columns of 4-9-5/Table 1 and in “A” and “D” columns of 4-9-6/Table 1A through 4-9-6/Table 6, as applicable. Alternative monitored parameters, which may provide equal effectiveness, will be considered.

9.3 Operator Interface

Where a computer is used as the operator interface to display monitoring information, the centralized control station is to be provided with at least two computers, including keyboards and monitors, unless other means of display are provided capable of displaying the same information.

9.5 Engineer’s Alarm

Where alarms are not acknowledged at the centralized control station in a pre-set period of time (e.g., 2 minutes), the system is to activate the engineers’ alarm audible in the engineers’ accommodations (see also 4-9-6/19.1).

11 Safety System

Safety system functions are to be in accordance with 4-9-2/9.5. As a minimum, safety shutdowns specified in 4-9-2/9.3 are to be provided. Where desired, safety system functions specified in “Auto start”, “Auto slowdown” and “Auto shutdown” columns in 4-9-6/Table 1A through 4-9-6/Table 6 may be provided. Override of safety system functions is to be as in 4-9-2/9.5.3.

13 Specific Requirements for Propulsion and Auxiliary Machinery

The following are requirements for control, monitoring and safety systems applicable to individual propulsion and auxiliary machinery plant supplemental to those of 4-9-5/7 through 4-9-5/11 above.

13.1 Propulsion Diesel Engines

Alarms and displays (“A” and “D” columns) in 4-9-6/Table 1A and 4-9-6/Table 1B are applicable. Safety system functions (Auto start, Auto shutdown, and Auto slowdown columns) in these tables are not mandatory for assigning **ACC** notation, except for automatic shutdowns required in 4-9-2/9.3.

13.3 Propulsion Gas Turbines

Alarms and displays (“A” and “D” columns) in 4-9-6/Table 3 are applicable. Safety system functions (Auto start, Auto shutdown, and Auto slowdown columns) in these tables are not mandatory for assigning **ACC** notation, except for automatic shutdowns required in 4-9-2/9.3.

13.5 Propulsion Steam Turbines

Alarms and displays (“A” and “D” columns) in 4-9-6/Table 2 are applicable. Safety system functions (Auto start, Auto shutdown, and Auto slowdown columns) in these tables are not mandatory for assigning **ACC** notation, except for automatic shutdowns required in 4-9-2/9.3. The following are also to be complied with.

13.5.1 Guardian Valve Operation

The astern guardian valve is to open automatically as a result of a throttle trip or a maneuvering signal, such as the actuation of a specific switch or by movement of the throttle control into the maneuvering range. Failure of the guardian valve to open is to be alarmed at the centralized control station.

13.5.2 Sea Water Main Circulating Pump

Where scoop circulation is provided for the main condenser, a low water supply situation is to be alarmed to allow manual starting of the main circulating pump. Alternatively, the pump may be automatically started as vessel speed reduces or as required by the design of the cooling system for satisfactory operation of the propulsion machinery.

13.7 Electric Propulsion

Alarms and displays (“A” and “D” columns) in 4-9-6/Table 4 are applicable. Safety system functions (Auto start, Auto shutdown, and Auto slowdown columns) in these tables are not mandatory for assigning **ACC** notation, except for automatic shutdowns required in 4-9-2/9.3.

13.9 Generators and Electrical Systems

Alarms and displays (“A” and “D” columns) in 4-9-5/Table 1 and 4-9-6/Table 6 are applicable. Safety system functions (Auto shutdown column) in 4-9-6/Table 6 are not mandatory for assigning **ACC** notation, except for automatic shutdowns required in 4-9-2/9.3. The following are also to be complied with.

13.9.1 Starting of Generators

In addition to complying with 4-8-2/3.11 for automatically restoring power to equipment necessary for propulsion, steering and safety, arrangements are to be provided to enable manually starting, stopping, synchronizing, paralleling and placing in service any generator from a single location. This location is to be at the main switchboard or may be at the centralized control console, if the main switchboard is located in the centralized control station.

13.9.2 Monitoring of Generators

Where the main switchboard is not located in the centralized control station, alarms and displays for monitoring the generators and main switchboard, as indicated in 4-9-5/Table 1, are to be provided in the centralized control station.

13.11 Boilers and Fired Equipment

13.11.1 Propulsion Boilers and Auxiliary Boilers Supporting Propulsion

In addition to the safety shutdowns required in 4-9-2/9.3 and 4-4-1/11.5.1 and 4-4-1/11.5.2, the following provisions are to be complied with:

- i)* For propulsion boilers, alarms and displays (“A” and “D” columns) in 4-9-6/Table 5A.
- ii)* For auxiliary boilers, necessary to support operation of propulsion (including power generation) alarms and displays (“A” and “D” columns) in 4-9-6/Table 5B. See also 4-9-5/13.11.2.
- iii)* For boilers fitted with automatic control, the provisions of 4-4-1/11.5.3.

Except when in local control, remote override of safety shutdowns specified in 4-9-2/9.3 and 4-4-1/11.5.1 is not permitted.

13.11.2 Monitoring of Auxiliary Boilers

Auxiliary boilers necessary to support operation of propulsion, including ship service electric power supply, may be fitted with a summary alarm and display located in the centralized control and monitoring station in lieu of 4-9-5/13.11.ii), provided:

- i)* The boiler is fitted with automatic control.
- ii)* The boiler is fitted with local control station and is not intended for remote control.
- iii)* The local control station is fitted with all controls, safety provisions, alarms and displays in 4-9-6/Table 5B (except that salinity alarm and display may be provided at the centralized control and monitoring station).
- iv)* The centralized control and monitoring station is provided with the display for “boiler running”, and summary alarms for “boiler abnormal” and “boiler shutdown”. The “boiler abnormal” alarm is to be activated by any of the alarms listed in 4-9-6/Table 5B.

13.11.3 Other Fired Equipment

Fired auxiliary boilers not related to supporting the operation of propulsion machinery are to comply with the requirements in 4-4-1/11.5.1 and 4-4-1/11.5.2. If the boiler is fitted with automatic control, 4-4-1/11.5.3 is also to be complied with.

Thermal oil boilers and incinerators are to meet 4-4-1/13.3.2 and 4-4-1/15.3, respectively.

13.13 Propulsion Auxiliaries

The centralized control station is to be provided with means to remotely start and stop auxiliary pumps associated with the operation of the following:

- Propulsion engine
- Electrical power generators
- Controllable pitch propellers
- Propulsion boilers and boilers supporting propulsion (including power generation)
- Fuel oil transfer system

Automatic transferring of vital auxiliary pumps, where fitted, is to be alarmed at the centralized control station.

15 Propulsion Machinery Space

15.1 Fuel Oil System Arrangements

15.1.1 Fuel Oil Settling and Service Tanks

Low level conditions of fuel oil settling and daily service tanks are to be alarmed at the centralized control station. Where automatic filling is provided, the arrangements are to include automatic pump shutdown and start-up at predetermined high and low levels, respectively. In such cases, fuel oil high level alarm is also to be provided.

15.1.2 Fuel Oil Overflow and Drain Tanks

Fuel oil overflow tanks and fuel oil drain tank receiving fuel oil from drip pans, spill trays and other leakage containment facilities are to be fitted with a high level alarm at the centralized control station.

15.1.3 Fuel Oil Heating

Fuel oil tanks provided with heating arrangements and fuel oil heaters are to be fitted with the following alarms at the centralized control station. See also 4-6-4/13.5.7 and 4-6-4/13.7.4.

- i)* High temperature alarm and temperature display for the heated fuel oil in the settling and service tanks.
- ii)* Fuel oil high temperature (or low viscosity) alarm, or a low flow alarm at the heater outlet. This alarm may be omitted if a fuel oil high temperature alarm required by 4-9-6/Table 1A through 4-9-6/Table 6 monitors the fuel oil high temperature for the heaters also.
- iii)* High temperature alarm for the fluid heating medium (steam, thermal oil, etc.) for fuel oil tanks or fuel oil heater, where the maximum temperature of the heating medium would exceed 220°C (428°F).

15.1.4 Use of Cargo as Propulsion Fuel

Vessels carrying liquefied natural gases that utilize methane as fuel in propulsion machinery spaces are to meet the provisions of Section 5C-8-16. The monitoring of gas supply, shutoff valve and propulsion machinery space ventilation, as required therein, are to be fitted at the centralized control station.

15.3 Bilge Level Monitoring

15.3.1 Bilge Level

The propulsion machinery space is to be provided with two independent systems to detect excessive rise of bilge water in the bilges or bilge wells. The arrangements including the number of sensors and locations are to be such that accumulation of bilge water may be detected at the various angles of vessel's heel and trim during and following any single fault to a sensor, wire, or control and monitoring system component. The alarm is to be given in the centralized control station.

For a machinery space with one bilge well port, one bilge well center, and one bilge well starboard, two bilge level sensors are required in each bilge well such that a fault in one sensor, wire, or control and monitoring system component does not prevent detection and alarm of high bilge level at various angles of vessel's heel and trim.

15.3.2 Bilge Pump

Where the bilge pumps are arranged for automatic operation, means are to be provided to indicate, at the centralized control station, when the pump is operating more frequently than would normally be expected, or when the pump is operating for an excessive length of time. Additionally, attention is to be given to oil pollution prevention requirements.

15.5 Fire Safety

15.5.1 Fire Detection and Alarm Systems

Propulsion machinery space is to be provided with a fixed fire detection and alarm system complying with 4-7-2/1.13.1 (or Regulation II-2/7 of SOLAS 1974). This fixed fire detection and alarm system may be combined with other fire detection and alarm systems required on board the vessel. The fire control panel is to be located on the navigation bridge or in the fire fighting station, if fitted. If located in the fire fighting station, a repeater panel is to be fitted on the navigation bridge. Propulsion machinery space fire is to be alarmed in the centralized control station.

15.5.2 Fire Main System

In order to provide immediate water delivery from the fire main system at a suitable pressure, provisions are to be made to remotely start one of the main fire pumps at the navigation bridge, unless the fire main is permanently pressurized. See 4-7-3/1.5.5 (or Regulation II-2/10.2.1.2.2.2 of SOLAS).

The remote starting is to be provided also at the fire control station, if fitted. Alternatively, means provided at fire fighting station to start the emergency fire pump, as in 4-9-6/21.3ix), may be considered as satisfying this requirement.

17 Equipment

Components, equipment, subsystems, etc., used in control, monitoring and safety systems of propulsion machinery, propulsion boilers and vital auxiliary pumps are to be designed and tested in accordance with the provisions in Section 4-9-9.

TABLE 1
Instrumentation and Controllers in Centralized Control Station –
All Propulsion and Auxiliary Machinery

<i>System</i>	<i>Monitored/Controlled Parameter</i>		<i>A</i>	<i>D</i>	<i>C</i>	<i>Notes</i> [A= Alarm; D= Display; C= Controller/Actuator] [x= applies]
Propulsion control and monitoring	A1	As in 4-9-2/Table 2 items A1 through C2, with follow additional features	x	x	x	Following items of 4-9-2/Table 2 are to be modified: - Item A4: additional telegraph is not required for centralized control station. - Item A6: starting of propulsion engine is required for all engine types - Item C1: acknowledgement switch for transfer of control station is not required in centralized control station
	A2	System power supply main and emergency feeders: failure, status and transfer	x	x	x	
	A3	Propulsion engine auxiliaries and boiler auxiliaries – status and start/stop		x	x	Automatic start/stop, if fitted, is to be alarmed. Applicable to propulsion boilers and boilers supporting propulsion.
	A4	Controllable pitch propeller (CPP) hydraulic power unit start/stop		x	x	
	A5	CPP hydraulic oil pressure – low and high	x			High-pressure alarm is required only if required by design. See 4-3-3/5.13.4(b)
	A6	CPP hydraulic oil temperature – high	x			If it is a system design feature
	A7	CPP hydraulic oil tank level – low	x			
	A8	Steam turbine shaft stopped – excess of set period	x			
	A9	Steam turbine shaft rollover – activated		x	x	To be activated automatically for ACCU
Electric Power Generating Plant	B1	Starting, paralleling & putting generator on line			x	Not required if main switchboard is located in the centralized control station
	B2	Generator running		x		
	B3	Voltage – high and low	x	x		
	B4	Current – high	x	x		
	B5	Frequency – high and low	x	x		
	B6	Failure of on-line generator	x			
	B7	Generator engine auxiliaries start/stop		x	x	Automatic start/stop, if fitted, is to be alarmed
	B8	Bearing lub oil inlet pressure – low	x	x		Automatic shutdown prime mover. 4-8-3/3.11.3.
	B9	Generator cooling inlet pump or fan motor – fails	x			4-8-3/3.11.4
	B10	Generator cooling medium temp. – high	x	x		4-8-3/3.11.4
High voltage rotating machine	C1	Stationary windings temperature – high	x			4-8-5/3.7.3(c)

TABLE 1 (continued)
Instrumentation and Controllers in Centralized Control Station –
All Propulsion and Auxiliary Machinery

<i>System</i>	<i>Monitored/Controlled Parameter</i>		<i>A</i>	<i>D</i>	<i>C</i>	<i>Notes</i> [A= Alarm; D= Display; C= Controller/Actuator] [x= applies]
Fuel oil system	D1	Settling and service tank level – low and high	x			High level alarm required only if automatic filling is provided, or if ACCU
	D2	Overflow tank and drain tank level – high	x			
	D3	Transfer pump start/stop		x	x	Start/stop may be automatic.
	D4	Heated fuel oil in settling and service tank, fuel oil temperature – high	x	x		4-6-4/13.5.7(b), 4-9-5/15.1.3i)
	D5	Fuel oil tank heating medium temperature – high	x			4-6-4/13.5.7(c), 4-9-5/15.1.3iii)
	D6	Fuel oil heater, fuel oil temperature – high (or viscosity – low) or flow – low	x			4-6-4/13.7.4(b), 4-9-5/15.1.3ii)
	D7	Fuel oil heater, heating medium temperature – high	x			4-6-4/13.7.4(c), 4-9-5/15.1.3iii)
Stern tube lub. oil	E1	Tank level – low	x			
Boiler, thermal oil heater, incinerator, etc.	F1	Automatic shutdown	x			Propulsion boilers and auxiliary boilers supporting propulsion are to meet 4-9-6/Table 5A and 4-9-6/Table 5B
Propulsion machinery space	G1	Bilge level – high	x			
	G2	Bilge pump status	x	x		Alarm applicable to automatically started bilge pump that starts/stops excessively or running unduly long
	G3	Fire detected	x			
	G4	Air condition system – fails	x			If necessary for equipment environmental control

Display = display of the analog or digital signal for the monitored parameter. The display of the signal is to provide indication of the monitored parameter in engineering units (such as degrees, PSI, RPM, etc.) or status indication. The engineering unit is to effectively display the relevant information concerning the monitored parameter. An alternative engineering unit which provides equivalent effectiveness, may be considered.

4

CHAPTER 9 Automation

SECTION 6 ACCU Notation

1 Application

Where it is intended that the propulsion machinery space be periodically unattended and that propulsion machinery be controlled primarily from the navigation bridge and from a centralized control and monitoring station installed within, or adjacent to, a periodically unattended propulsion-machinery space, the provisions of 4-9-6/3 and 4-9-6/5 are to be complied with. These provisions cover propulsion machinery during start-up, navigating and maneuvering, but do not cover operations in port or at mooring or anchorage.

The notation **ACCU** will be assigned upon verification of compliance and upon satisfactory tests and trials carried out in accordance with the provisions of Section 4-9-10 in the presence of a Surveyor.

3 System Requirements

3.1 General

In general, the vessel is to be fitted with:

- i)* A remote propulsion control station on the navigation bridge complying with 4-9-6/1 with capability to monitor the propulsion machinery space and the machinery plant
- ii)* A centralized control station complying with Section 4-9-5, which is to be further provided with safety system functions capable of taking automated corrective actions in the event of a fault in the machinery plant; such a station may be periodically unattended
- iii)* A monitoring station in the engineers' quarters capable of alarming any undesirable state of the propulsion machinery space and of the machinery plant
- iv)* A fire fighting station with means to effect rapid response to control fire in the propulsion machinery space

These stations are to comply also with the provisions of 4-9-6/5 through 4-9-6/21 hereunder.

3.3 Duration of Unattended Operation

The extent of automation, monitoring and remote control is to be such as to allow unattended propulsion machinery space operations for at least 24 hours. For duration less than 24 hours, the limitation will be noted in the classification record.

3.5 System Criteria

In general, conceptual requirements in 4-9-2/3.1 are applicable. Specific details are provided in 4-9-6/5 through 4-9-6/21. FMEA (4-9-2/3.1.5) is to be conducted to demonstrate that control, monitoring and safety systems are so designed that any single failure will not result in the loss of propulsion control, the loss of propulsion or other undesirable consequences. The FMEA report is to be submitted for review.

3.7 System Power Supply

System power supply is to comply with 4-9-5/3.5. In addition, the power supply status display and the alarm of the failure of either power source are also to be provided at the navigation bridge.

5 Navigation Bridge

Remote propulsion control is to be provided on the navigation bridge. The required controls and associated alarms and displays are to comply with 4-9-2/13 and 4-9-2/Table 2. Additional alarms, displays and controls, as specified at the lower half of 4-9-2/Table 2, are also to be provided.

7 Location of Centralized Control Station

Location of centralized control station is to comply with 4-9-5/5.

9 Remote Control from Centralized Control Station

Remote controls of propulsion and auxiliary machinery from the centralized control station are to comply with 4-9-5/7. See also “C” column of 4-9-5/Table 1.

11 Monitoring in Centralized Control Station

Monitoring in centralized control station is to comply with 4-9-5/9. Alarms and displays (“A” and “D” columns) in 4-9-6/Table 1A through 4-9-6/Table 6 and 4-9-5/Table 1, as applicable, are to be provided. Engineer’s alarms are to comply with 4-9-6/19 hereunder.

13 Safety Systems

13.1 General

To allow for unattended operation, the centralized control station is to be provided with safety system functions specified in “Auto start”, “Auto slowdown” and “Auto shutdown” columns of 4-9-6/Table 1A through 4-9-6/Table 6. The following features are also applicable.

13.3 System Design

In addition to complying with 4-9-2/9.1, the following are applicable in order to safeguard continued operation of machinery:

- i) Safety system is to be designed to take the least drastic action first in response to a fault, and when this fails to avert the situation, to intervene sequentially with more drastic actions. The system is to incorporate ability to automatically start a standby pump, or automatic slowdown or automatic shutdown of propulsion machinery, as applicable.
- ii) For propulsion machinery (4-9-6/Table 1A through 4-9-6/Table 5A), automatic start/ changeover, automatic slowdown and automatic shutdown systems are to be independent of monitoring and control systems. However, common sensors as specifically indicated in these tables may be allowed.
- iii) In lieu of automatic slowdown, illuminated warning sign “reduced power” with audible alarm may be provided on the navigation bridge to allow manual slowdown to be effected.
- iv) Overrides for safety system actions are to comply with 4-9-2/9.5.3.

13.5 Automatic Start and Changeover

In the event of detecting low or the loss of system pressure, as specified in 4-9-6/Table 1A through 4-9-6/Table 3 and 4-9-6/Table 5A (in “Auto start” column), automatic startup of and changeover to the standby pumps, which are essential to maintain the running of the propulsion machinery, are to be provided.

Where power is automatically restored following a blackout as per 4-8-2/3.11, auxiliaries that are essential for propulsion and maneuvering are to be automatically started. In order not to overload the generator while the motors are starting, means such as sequential starting are to be provided where necessary.

13.7 Automatic Slowdown

Automatic slowdown, where indicated in 4-9-6/Table 1A, 4-9-6/Table 1B and 4-9-6/Table 2, is to be provided in order to maintain the continuous operation of the propulsion machinery in the event of specified alarm conditions.

13.9 Automatic Shutdown

Automatic shutdowns are to be provided, where indicated in 4-9-6/Table 1A through 4-9-6/Table 5A, to protect the propulsion machinery from serious damage. Where automatic shutdown is indicated in these tables as a requirement along with 4-9-6/13.5 or 4-9-6/13.7 or both, the intent is that either 4-9-6/13.5 or 4-9-6/13.7 or both is to be activated first; and if the state of the propulsion machinery does not improve, then 4-9-6/13.9 is to be activated.

15 Specific Requirements for Propulsion and Auxiliary Machinery

The following are requirements for control, monitoring and safety systems of individual propulsion and auxiliary machinery plant supplemental to those of 4-9-6/9 through 4-9-6/13 above.

15.1 Automatic Starting of Propulsion Auxiliaries

Where power is automatically restored following a blackout as per 4-8-2/3.11, auxiliaries that are essential for propulsion and maneuvering are to be automatically started. In order not to overload the generator while the motors are starting, means such as sequential starting are to be provided where necessary.

15.3 Propulsion Steam Turbine

In addition to the safety system functions in 4-9-6/Table 2 and in the event of loss of lubricating oil, automatic or manual means are to be provided to allow braking steam to be applied to the turbine.

15.5 Boilers

15.5.1 Propulsion Boilers

Propulsion boilers are to be capable of automatically and safely satisfying the steam requirements demanded from the boiler under normal evaporation between minimum and maximum firing rates and be able to maintain complete and stable combustion at the minimum rate of firing or during any sudden change in steam demand. In addition to 4-4-1/11.5.1 through 4-4-1/11.5.3 and 4-9-6/Table 5A, the following are to be complied with.

15.5.1(a) Prevention of excessive steam. To prevent a build-up of excessive propulsion boiler steam which might occur when all burners are in service and the burners are at the minimum firing rate, one of the following arrangements, or equivalent, is to be provided.

- i) Burner sequencing, which may require automatic control of one or more, but not necessarily all, burners in the boiler.
- ii) An automatic steam dump system unloading to a condenser of adequate size.
- iii) For long-term port operation at low loads, the excess burner capacity may be secured.

15.5.1(b) Starting inhibition. Means are to be provided to prevent boiler start up whenever unsafe firing conditions (e.g., forced draft failure, low water level) exist. Such conditions are to be alarmed. Means are also to be provided to prevent startup following a shutdown, unless manually reset.

15.5.1(c) *Boiler control program.* Automatically started boilers are to be provided with a programmed control. The programmed control is to be designed to cycle the boiler in accordance with a predetermined sequence and, in addition to the automatic boiler purge in 4-9-6/15.5.1(b), is to include the following events:

- i) Ignition timing: ignition (spark coming on) is to precede the opening of the fuel valve.
- ii) Modulated air fuel ratio: where it is necessary to cut burners in and out to handle the load on the boiler, and controls are provided to modulate the air-fuel ratio, the automatic boiler purge period is to start with the modulating control in the high-firing position (air registers in maximum opening position) and ignition is not to be turned on until the modulating control has returned to the low-firing position (air registers in minimum opening position).

15.5.2 Other Boilers and Fired Equipment

Fired auxiliary boilers necessary to support operation of propulsion (including power generation) are to comply with 4-9-5/13.11.1ii), 4-9-5/13.11.1iii) and 4-9-5/13.11.2. Other boilers and fired equipment are to comply with 4-9-5/13.11.3.

17 Propulsion Machinery Space

The provisions of 4-9-5/15 are to be met. In addition, where automatic filling is provided, each of the fuel oil settling or service tanks is to be of a capacity sufficient for at least eight (8) hours operation at normal power.

Where automatic filling is not provided, the capacity of each of these tanks is to be sufficient for at least 24 hours operation at normal power. Otherwise, a time limitation will be noted in the classification record.

19 Monitoring Station in the Engineers' Quarters

19.1 Engineers' Public Space and Engineers' Cabins

At least one alarm monitoring station is to be provided in the engineers' public space, such as the officers' lounge or officers' mess room. Where the engineer on-duty is assigned to work in a specific space, such as the ship's office or engineers' office, then such a space is also to be provided with duty alarm monitoring station. In addition, duty alarm monitoring station is to be provided in each engineer's cabin hard-wired through a selector switch so arranged as to ensure connection to at least one of these cabins. Each station is to be provided with:

- An alarm for fire in the propulsion machinery space
- An alarm for high bilge water level in the propulsion machinery space
- A summary-alarm to be activated by any of the alarm conditions listed in 4-9-6/Table 1A through 4-9-6/Table 6 and 4-9-5/Table 1

The fire alarm is to have a separate visual display and a distinct sound from the summary alarm, and other alarms, where fitted. Selector switch is not to be provided for fire alarm.

19.3 Muting the Audible Alarms

All alarms in 4-9-6/19.1 are to be silenced only at the centralized control station. Alternatively, arrangements may be made to silence the summary and the bilge alarms at the alarm monitoring stations in the engineers' public space or at a selected engineer's cabin, provided the associated visual alarm is not extinguished. The arrangements are to be such that if the audible alarm is not also silenced manually at the centralized control station in a preset period of time (e.g., two (2) minutes), the system is to activate the engineer's alarm (see 4-8-2/11.7.2).

19.5 Communication

The communication system required by 4-8-2/11.5.1 is to include the engineer's accommodation area.

21 Fire Safety

21.1 Fire Fighting Station

A fire-fighting station is to be provided and to be located outside the propulsion machinery space. However, consideration may be given to the installation of the fire-fighting control station within the room housing the centralized control station, provided that the room's boundary common with the propulsion machinery space, including glass windows and doors, is insulated to A-60 standard. The doors opening into the propulsion machinery space are to be self-closing. The ventilation system to the room is to be separate from other systems serving the propulsion machinery space and the ventilation inlet is to be taken from a safe space outside the propulsion machinery space. There is to be a protected access, insulated to A-60 standard, from the room to the open deck.

21.3 Controls at Fire Fighting Station

The fire-fighting station is to be provided with remote manual controls for the operations detailed in the following list:

- i)* Shutdown of ventilation fans serving the machinery space. See 4-8-2/11.9.1.
- ii)* Shutdown of fuel oil, lubricating oil and thermal oil system pumps. See 4-8-2/11.9.2.
- iii)* Shutdown of forced and induced draft fans of boilers, inert gas generators and incinerators, and of auxiliary blowers of propulsion diesel engines. See 4-8-2/11.9.3.
- iv)* Closing of propulsion machinery space fuel oil tanks suction valves. This is to include other forms of fuel supply, such as gas supply valves in LNG carriers
- v)* Shutdown of fixed local application fire fighting systems, see 4-7-2/1.11.2, before activation of a high-expansion foam fire extinguishing system, see 4-7-3/5.1, to avoid adverse water action on the foam.
- vi)* Closing of propulsion machinery space skylights, openings in funnels, ventilator dampers and other openings. Where the propulsion machinery space is protected by a high-expansion foam fire extinguishing system complying with 4-7-3/5.1, the remote means of closing the upper level ventilation openings is not required from the fire-fighting station, provided the lower edge of the door is located 1 meter (3.3 ft) above the highest point of any fire risk objects. For closing of openings see 4-7-2/1.9.7.
- vii)* Closing of propulsion machinery space watertight, weathertight and fire-resistant doors. Self-closing doors with no hold back arrangements may be excluded. Where the propulsion machinery space is protected by a high-expansion foam fire extinguishing system complying with 4-7-3/5.1, the remote control of the doors fitted on machinery casings which are exposed to weather decks is not required, provided the lower edge of the door is located 1 meter (3.3 ft) above the highest point of any fire risk objects.
- viii)* Starting of emergency generator where it is not arranged for automatic starting.
- ix)* Starting of a fire pump located outside of the propulsion machinery space, including operation of all necessary valves, to pressurize the fire main. However, valves located near the pump need not be provided with remote operation from the firefighting station, if they are kept locked open (LO), or closed (LC), as appropriate, to provide immediate water supply to the fire main. The position of the valves (open or closed) is to be clearly marked. Where the sea chest valve is located in the same compartment as the fire pump and the sea chest valve is kept locked open, a high-level bilge alarm is to be fitted in the fire pump space. If the sea chest is located in a different space than the compartment containing the fire pump, then a high-level bilge alarm is to be fitted in the fire pump space, as well as the compartment containing the sea chest, in order to detect possible flooding in each of these spaces. The high-level bilge alarm is to sound in the centralized control station. Starting of one of the main fire pumps is also to be provided on the navigation bridge (see 4-9-5/15.5.2).
- x)* Actuation of the fixed fire extinguishing system for the propulsion machinery space. This release is to be manual and not initiated automatically by signals from the fire-detecting system.

21.5 Fire Detection and Alarm Systems

21.5.1 General

The propulsion machinery space is to be provided with a fixed fire detection and alarm system complying with 4-7-2/1.13.1. This fixed fire detection and alarm system may be combined with other fire detection and alarm systems required onboard the vessel. The fire control panel is to be located on the navigation bridge or in the fire fighting station. If located in the fire fighting station, a repeater panel is to be fitted on the navigation bridge. Propulsion machinery space fire is to be alarmed in the centralized control station.

21.5.2 Temporarily Disconnecting Alarms

A fire detector loop or detector(s) covering the unattended machinery space may be temporarily disabled, for example, for maintenance purposes, provided that such action is to be clearly indicated at the fire control panel and at the centralized control station described in 4-9-6/21.5.1. Disabled loop or detectors are to be reactivated automatically after a preset time period.

21.5.3 Fire Alarm Call Points

Manually operated fire alarm call points are to be provided at the following locations:

- Centralized control station
- Passageways leading to the propulsion machinery spaces
- Navigation bridge

21.7 Portable Fire Extinguishers

In addition to the portable fire extinguishers located in the machinery space, as required by 4-7-2/1, and the spare charges, as required by 4-7-3/15.1.2, an equal number of portable extinguishers, as required by 4-7-2/1, are to be provided. These extinguishers are to be stored in or in the vicinity of the fire-fighting station, or at the entrance to the propulsion machinery space

Where, in lieu of spare charges, duplicated portable extinguishers are provided to satisfy the requirement of 4-7-3/15.1.2, these duplicated extinguishers may be considered to have satisfied the above requirement, provided that they are stored as indicated above.

23 Equipment

Components, equipment, subsystems, etc., used in control, monitoring and safety systems of propulsion machinery, propulsion boilers and vital auxiliary pumps are to be designed and tested in accordance with the provisions of Section 4-9-9.

TABLE 1A
Instrumentation and Safety System Functions in Centralized Control Station –
Slow Speed (Crosshead) Diesel Engines

System	Monitored Parameter		A	D	Auto Slow down	Auto Start	Auto Shut down	Notes [A = alarm. D = display. x = apply.]
Sensors	Common or separate		c	c	c	s	s	c = common; s = separate
Fuel oil	A1	Fuel oil after filter (engine inlet), pressure – low	x	x		x		
	A2	Fuel oil before injection pumps, temp. – high (or viscosity – low)	x					
	A3	Fuel oil before injection pumps, temp. – low (or viscosity – high)	x					
	A4	Leakage from high pressure pipes	x					
	A5	Fuel oil service tank, level – low	x					High level alarm is also required if without suitable overflow arrangements.
	A6	Common rail fuel oil pressure – low	x					
Lubricating oil	B1	Lub. oil to main bearing and thrust bearing, pressure – low	x	x	x	x	x	.
	B2	Lub. oil to crosshead bearing, pressure – low	x	x	x	x	x	If of a different system.
	B3	Lub. oil to camshaft, pressure – low	x			x	x	If of a different system.
	B4	Lub. oil to camshaft, temp. – high	x					If of a different system.
	B5	Lub. oil inlet, temp. – high	x					
	B6	Thrust bearing pads temp. or bearing outlet temp. – high	x		x		x	
	B7	Oil mist in crankcase, mist concentration – high; or Bearing temperature – high; or Alternative arrangements	x		x			For engines having a power of 2250 kW (3000 hp) and above or having a cylinder bore of more than 300 mm (11.8 in.). See 4-2-1/7.2.
	B8	Each cylinder lubricator, flow rate – low	x		x			
	B9	Lub. oil tanks, level – low	x					Where separate lubricating oil systems are installed (e.g. camshaft, rocker arms, etc.), individual level alarms are required for all the tanks.
	B10	Common rail servo oil pressure – low	x					
Turbocharger	C1	Lub. oil inlet, pressure – low	x					Unless provided with a self-contained lubricating oil system integrated with the turbocharger
	C2	Lub. oil outlet (each bearing), temp. – high	x					Where outlet temperature from each bearing cannot be monitored due to the engine/turbocharger design, alternative arrangements may be accepted. Continuous monitoring of inlet pressure and inlet temperature in combination with specific intervals for bearing inspection in accordance with the turbocharger manufacturer's instructions may be accepted as an alternative.
	C3	Speed	x	x				Alarm Activation for High Speed only required for turbochargers of categories B and C

TABLE 1A (continued)
Instrumentation and Safety System Functions in Centralized Control Station –
Slow Speed (Crosshead) Diesel Engines

System	Monitored Parameter	A	D	Auto Slow down	Auto Start	Auto Shut down	Notes [A = alarm. D = display. x = apply.]
Piston cooling	D1 Coolant inlet, pressure – low	x		x	x		The slow down is not required if the coolant is oil taken from the main cooling system of the engine.
	D2 Coolant outlet (each cylinder), temp. – high	x		x			
	D3 Coolant outlet (each cylinder), flow – low	x		x			Where outlet flow cannot be monitored due to engine design, alternative arrangements may be accepted.
	D4 Coolant in expansion tank, level – low	x					
Sea water cooling	E1 Sea water cooling, pressure – low	x			x		
Cylinder fresh water cooling	F1 Water inlet, pressure – low	x		x	x		
	F2 Water outlet from each cylinder, temp. – high; or common water outlet, temp. – high	x		x			Sensing at common water outlet is permitted for cylinder jackets fitted with common cooling space without intervening stop valves.
	F3 Oily contamination of engine cooling water system.	x					Where engine cooling water is used in fuel and lubricating oil heat exchangers.
	F4 Cooling water expansion tank, level – low	x					
Compressed air	G1 Starting air before main shutoff valve, pressure – low	x	x				
	G2 Control air, pressure – low	x					
	G3 Safety air, pressure – low	x					
Scavenge air	H1 Scavenge air receiver, pressure		x				
	H2 Scavenge air box, temp. – high (fire)	x		x			
	H3 Scavenge air receiver water level – high	x					
Exhaust gas	I1 Exhaust gas after each cylinder, temp. – high	x	x	x			
	I2 Exhaust gas after each cylinder, deviation from average, temp. – high	x					
	I3 Exhaust gas before each turbocharger, temp. – high	x	x				
	I4 Exhaust gas after each turbocharger, temp. – high	x	x				
Fuel valve coolant	J1 Coolant, pressure – low	x			x		
	J2 Coolant, temp. – high	x					
	J3 Coolant expansion tank, level – low	x					
Engine	K1 Speed/direction of rotation		x				
	K2 Rotation – wrong way	x					
	K3 Engine overspeed	x				x	
Power	L1 Control, alarm or safety system, power supply failure	x					

TABLE 1A (continued)
Instrumentation and Safety System Functions in Centralized Control Station –
Slow Speed (Crosshead) Diesel Engines

Display	=	display of the analog or digital signal for the monitored parameter. The display of the signal is to provide indication of the monitored parameter in engineering units (such as degrees, PSI, RPM, etc.) or status indication. The engineering unit is to effectively display the relevant information concerning the monitored parameter. An alternative engineering unit which provides equivalent effectiveness, may be considered.
Auto slowdown	=	automatic slowdown of diesel engine, along with activation of suitable alarm.
Auto start	=	automatic starting of a standby pump, along with activation of suitable alarm.
Auto shutdown	=	automatic stopping of the diesel engines, along with activation of suitable alarm.

TABLE 1B
Instrumentation and Safety System Functions in Centralized Control Station –
Medium and High Speed (Trunk Piston) Diesel Engines

System	Monitored Parameter	A	D	Auto Slow down	Auto Start	Auto Shut down	Notes [A = alarm. D = display. x = apply.]
Sensors	Common or separate	c	c	c	s	s	c = common; s = separate
Fuel oil	A1 Fuel oil after filter (engine inlet), pressure – low	x	x		x		
	A2 Fuel oil before injection pumps, temp. – high (or viscosity – low)	x					For heavy fuel oil burning engines only.
	A3 Fuel oil before injection pumps, temp. – low (or viscosity – high)	x					For heavy fuel oil burning engines only.
	A4 Leakage from high pressure pipes	x					
	A5 Fuel oil service tank, level – low	x					High level alarm is also required if without suitable overflow arrangements.
	A6 Common rail fuel oil pressure – low	x					
Lubricating oil (diesel engine)	B1 Lub. oil to main bearing and thrust bearing, pressure – low	x	x		x	x	
	B2 Lub. oil filter differential, pressure – high	x	x				
	B3 Lub. oil inlet, temp. – high	x	x				
	B4 Oil mist in crankcase, mist concentration – high; or Bearing temperature - high; or Alternative arrangements	x				x	For engines having a power of 2250 kW (3000 hp) and above or having a cylinder bore of more than 300 mm (11.8 in.). Single sensor having two independent outputs for initiating alarm and for shutdown will satisfy independence of alarm and shutdown. See 4-2-1/7.2.
	B5 Each cylinder lubricator, flow rate – low	x		x			If necessary for the safe operation of the engine.
	B6 Common rail servo oil pressure – low	x					
Lubricating oil (other than diesel engine)	B7 Reduction gear lub. oil inlet pressure – low	x	x	x	x	x	Shutdown is to affect all power input to gear
Sea water cooling	C1 Sea water cooling system pressure – low	x	x		x		
Cylinder fresh water cooling	D1 Water inlet, pressure – low or flow – low	x	x	x	x		
	D2 Water outlet (general), temp. – high	x	x	x			Two separate sensors are required for alarm and slowdown.
	D3 Cooling water expansion tank, level – low	x					
Compressed air	E1 Starting air before shutoff valve, pressure – low	x	x				
	E2 Control air pressure – low	x	x				
Scavenge air	F1 Scavenge air receiver temp. – high	x					

TABLE 1B (continued)
Instrumentation and Safety System Functions in Centralized Control Station –
Medium and High Speed (Trunk Piston) Diesel Engines

System	Monitored Parameter		A	D	Auto Slow down	Auto Start	Auto Shut down	Notes
								[A = alarm. D = display. x = apply.]
Exhaust gas	G1	Exhaust gas after each cylinder, temp. – high	x	x	x			For engine power > 500 kW/cylinder
	G2	Exhaust gas after each cylinder, deviation from average, temp. – high	x					For engine power > 500 kW/cylinder
Engine	H1	Speed		x				
	H2	Overspeed	x				x	
Power	J1	Control, alarm or safety system, power supply failure	x					
Turbocharger	K1	Turbocharger lub. oil inlet pressure – low	x					Unless provided with a self-contained lubricating oil system integrated with the turbocharger
	K2	Turbocharger lub. oil outlet temp., each bearing – high	x					Where outlet temperature from each bearing cannot be monitored due to the engine/ turbocharger design, alternative arrangements may be accepted. Continuous monitoring of inlet pressure and inlet temperature in combination with specific intervals for bearing inspection in accordance with the turbocharger manufacturer’s instructions may be accepted as an alternative.
	K3	Speed of turbocharger	x	x				Alarm Activation for High Speed only required for turbochargers of categories B and C

Display = display of the analog or digital signal for the monitored parameter. The display of the signal is to provide indication of the monitored parameter in engineering units (such as degrees, PSI, RPM, etc.) or status indication. The engineering unit is to effectively display the relevant information concerning the monitored parameter. An alternative engineering unit which provides equivalent effectiveness, may be considered.

Auto slowdown = automatic slowdown of diesel engine, along with activation of suitable alarm.

Auto start = automatic starting of a standby pump, along with activation of suitable alarm.

Auto shutdown = automatic stopping of the diesel engines, along with activation of suitable alarm.

TABLE 2
Instrumentation and Safety System Functions in Centralized Control Station – Propulsion Steam Turbines

System	Monitored Parameter	A	D	Auto Slow down	Auto Start	Auto Shut down	Notes (see also bottom of table) [A = alarm. D = display. x = apply.]
Sensors	Common or separate	c	c	c	s	s	c = common; s = separate
Lubricating oil	A1 Pressure at bearing inlets – low	x	x		x	x	For turbines, gears and thrust bearings.
	A2 Temp. at bearing inlet – high	x	x				For turbines, gears and thrust bearings.
	A3 Bearing temp. or bearing oil outlet temp. – high	x	x				For turbines, gears and thrust bearings.
	A4 Filter differential pressure – high	x					
	A5 Gravity tank and sump levels – low	x	x				
Lubricating oil cooling medium	B1 Pressure or flow – low	x	x		x		
	B2 Temp. at outlet – high	x					
	B3 Expansion tank level – low	x	x				
Sea water	C1 Pressure or flow – low	x	x		x		
	C2 Pump – auto starting and running		x				For vessels fitted with sea inlet scoops
	C3 Scoop valve – open/close		x				For vessels fitted with sea inlet scoops.
Steam	D1 Pressure at throttle – low	x				x	
	D2 Pressure, ahead chest		x				
	D3 Pressure, astern chest		x				
	D4 Pressure, gland seal		x				
	D5 Gland seal exhaust fan – failure	x					
	D6 Astern guardian valve – position		x				
	D7 Astern guardian valve – fail to open	x					In response to throttle trip or maneuvering signal.
Condensate	E1 Condenser level – high	x	x			x	
	E2 Condenser level – low	x	x				
	E3 Condensate pump pressure – low	x			x		
	E4 Condenser vacuum – low	x	x			x	
	E5 Salinity – high	x	x				
Turbine	F1 Vibration Level – high	x		x			
	F2 Axial Displacement – large	x				x	
	F3 Speed		x				
	F4 Overspeed	x				x	
	F5 Shaft rollover – activated		x				
	F6 Shaft stopped – excess of set period	x					Shaft rollover to be activated manually or automatically
Power	G1 Throttle control system power failure	x					

- Display = display of the analog or digital signal for the monitored parameter. The display of the signal is to provide indication of the monitored parameter in engineering units (such as degrees, PSI, RPM, etc.) or status indication. The engineering unit is to effectively display the relevant information concerning the monitored parameter. An alternative engineering unit which provides equivalent effectiveness, may be considered.
- Auto slowdown = automatic slowdown of turbine, with activation of suitable alarm.
- Auto start = automatic starting of standby pump in the system, with activation of suitable alarm.
- Auto shutdown = automatic closing of ahead steam throttle valve, with activation of suitable alarm; but to allow admission of steam to astern turbine for braking purposes.

TABLE 3
Instrumentation and Safety System Functions in Centralized Control Station –
Propulsion Gas Turbines

System	Monitored Parameter	A	D	Auto Start	Auto Shut down	Notes (see also bottom of table) [A = alarm. D = display. x = apply.]
Sensors	Common/separate	c	c	s	s	c = common sensor; s = separate sensor
Fuel oil	A1 Pressure or flow – low	x	x			
	A2 Temperature – high and low (or viscosity – low and high)	x	x			For heavy fuel oil.
Lubricating oil	B1 Inlet pressure – low	x	x	x	x	For turbines, reduction gears and thrust bearings
	B2 Inlet temperature – high	x	x			For turbines, reduction gears and thrust bearings
	B3 Main bearing temp. or main bearing oil outlet temp. – high	x	x			For turbines, reduction gears and thrust bearings
	B4 Filter differential pressure – high	x				
	B5 Tank level – low	x	x			
Cooling medium	C1 Pressure or flow – low	x	x			
	C2 Temperature – high	x				
Starting	D1 Stored starting energy level – low	x				
	D2 Ignition failure	x			x	
Combustion	E1 Combustion or flame failure	x			x	
Exhaust gas	F1 Temperature – high	x	x		x	
Turbine	G1 Vibration level – high	x			x	
	G2 Rotor axial displacement – large	x			x	Auto shutdown may be omitted for rotors fitted with roller bearings
	G3 Overspeed	x			x	
	G4 Vacuum at compressor inlet – high	x			x	
Control System	H1 Control, alarm or safety system, power supply failure	x				

Display = display of the analog or digital signal for the monitored parameter. The display of the signal is to provide indication of the monitored parameter in engineering units (such as degrees, PSI, RPM, etc.) or status indication. The engineering unit is to effectively display the relevant information concerning the monitored parameter. An alternative engineering unit which provides equivalent effectiveness, may be considered.

Auto start = automatic starting of standby pump in the system, with activation of suitable alarm.

Auto shutdown = automatic closing of main fuel valve, with activation of suitable alarm.

TABLE 4A
Instrumentation and Safety System Functions in Centralized Control Station –
Electric Propulsion

<i>System</i>	<i>Monitored Parameter</i>		<i>A</i>	<i>D</i>	<i>Auto Shut down</i>	<i>Notes</i> [A = Alarm; D = Display; x = apply]
Propulsion Generator	A1	Bearing lub. oil inlet pressure – low	x	x	x	Prime mover automatic shutdown
	A2	Voltage – off-limits	x	x		To read all phases and at least one bus
	A3	Frequency – off-limits	x	x		
	A4	Current		x		To read all phases
	A5	Stationary windings temperature – high	x	x		To read all phases; for generators >500 kW
	A6	Main generator circuit breakers – open/close		x		
	A7	Generator running		x		
	A8	Failure of on-line generator	x			
	A9	Transfer of standby generator	x			
	A10	Generator cooling medium temperature – high	x	x		If applicable
	A11	Failure of generator cooling pump or fan motor	x			If applicable
	A12	Field voltage and current		x		For DC generator
	A13	Inter-pole winding temperature – high	x	x		For DC generator
Propulsion Motor - AC	B1	Bearing, lub. oil inlet pressure – low	x	x	x	
	B2	Armature voltage – off-limits	x	x		To read all phases and at least one bus
	B3	Field voltage		x		
	B4	Frequency – off-limits	x	x		
	B5	Armature current		x		To read all phases
	B6	Field current		x		For synchronous motors
	B7	Ground lights or similar		x		
	B8	Stationary windings temperature – high	x	x		To read all phases; for motors > 500 kW
	B9	Motor circuit breakers – open/close		x		
	B10	Motor running		x		
	B11	Failure of on-line motor	x			
	B12	Transfer of standby motor	x			
	B13	Motor cooling medium temperature – high	x	x		If applicable
	B14	Failure of cooling pump or fan motor	x			If applicable
Propulsion Motor - DC	C1	Bearing lub. oil inlet pressure – low	x	x	x	
	C2	Armature voltage – off-limits	x	x		
	C3	Field voltage		x		
	C4	Armature current		x		
	C5	Field current		x		
	C6	Ground lights or similar		x		
	C7	Motor circuit breakers – open/close		x		
	C8	Motor running		x		
	C9	Motor overspeed	x		x	
	C10	Failure of on-line motor	x			
	C11	Transfer of standby motor	x			
	C12	Motor cooling medium temperature – high	x	x		If applicable
	C13	Failure of cooling pump or fan motor	x			If applicable

TABLE 4A (continued)
Instrumentation and Safety System Functions in Centralized Control Station –
Electric Propulsion

<i>System</i>	<i>Monitored Parameter</i>		<i>A</i>	<i>D</i>	<i>Auto Shut down</i>	<i>Notes</i> [<i>A = alarm. D = display. x = apply. </i>]
Propulsion SCR	D1	Voltage		x		
	D2	Current		x		
	D3	Overload (high current)	x			Alarms before protective device is activated
	D4	Open/close position for assignment switches		x		
	D5	SCR cooling medium temperature – high	x	x		If applicable
	D6	Failure of SCR cooling pump or fan motor	x			If applicable
	D7	Inter-phase reactor temperature, high	x	x		
Transformer	E1	Transformer winding temperature – high	x	x		For each phase

Display = display of the analog or digital signal for the monitored parameter. The display of the signal is to provide indication of the monitored parameter in engineering units (such as degrees, PSI, RPM, etc.) or status indication. The engineering unit is to effectively display the relevant information concerning the monitored parameter. An alternative engineering unit which provides equivalent effectiveness, may be considered.

TABLE 4B
Instrumentation and Safety System Functions in Centralized Control Station –
Generator Prime Mover for Electric Propulsion

Systems	Monitored Parameters		A	D	Auto Start	Auto Shut down	Notes [A = alarm. D = display. x = apply.]
<i>Trunk Piston Type Diesel Engines</i>							
Fuel oil	F1	Fuel oil after filter (engine inlet), Pressure – low	x	x	x		
	F2	Fuel oil before injection pumps, temp. – high (or viscosity – low)	x				For heavy fuel oil burning engines only.
	F3	Fuel oil before injection pumps, temp. – low (or viscosity – high)	x				For heavy fuel oil burning engines only.
	F4	Leakage from high pressure pipes	x				
	F5	Fuel oil service tank, level – low	x				High level alarm is also required if without suitable overflow arrangements.
	F6	Common rail fuel oil pressure – low	x				
Lubricating oil	G1	Lub. oil to main bearing, pressure – low	x	x	x	x	
	G2	Lub. oil filter differential, pressure – high	x	x			
	G3	Lub. oil inlet, temp. – high	x	x			
	G4	Oil mist in crankcase, mist concentration – high; or Bearing temperature – high; or Alternative arrangement	x			x	For engines having a power of 2250 kW (3000 hp) and above or cylinder bore of more than 300 mm (11.8 in.). Single sensor having two independent outputs for initiating alarm and for shutdown will satisfy independence of alarm and shutdown. See 4-2-1/7.2.
	G5	Each cylinder lubricator, flow rate – low	x				If necessary for the safe operation of the engine.
	G6	(2010) Common rail servo oil pressure – low	x				
Sea cooling water	H1	Sea water cooling system pressure – low	x	x	x		
Cylinder fresh water cooling	J1	Water inlet, pressure – low or flow – low	x	x	x		
	J2	Water outlet (general), temp. – high	x	x			
	J3	Cooling water expansion tank, level – low	x				
Compressed air	K1	Starting air before shutoff valve, pressure – low	x	x			
	K2	Control air pressure – low	x	x			
Exhaust gas	L1	Exhaust gas after each cylinder, temp. – high	x	x			For engine power > 500 kW/cylinder

TABLE 4B (continued)
Instrumentation and Safety System Functions in Centralized Control Station –
Generator Prime Mover for Electric Propulsion

Systems	Monitored Parameters		A	D	Auto Start	Auto Shut down	Notes
							[A = alarm. D = display. x = apply.]
Turbocharger	M1	Turbocharger oil inlet pressure – low	x				Unless provided with a self-contained lubricating oil system integrated with the turbocharger
	M2	Turbocharger oil outlet temp., each bearing – high	x				Where outlet temperature from each bearing cannot be monitored due to the engine/ turbocharger design, alternative arrangements may be accepted. Continuous monitoring of inlet pressure and inlet temperature in combination with specific intervals for bearing inspection in accordance with the turbocharger manufacturer’s instructions may be accepted as an alternative.
	M3	Speed of turbocharger	x				Alarm Activation for High Speed only required for turbochargers of categories B and C.
Engine	N1	Over speed	x			x	
Power Supply	P1	Main	x	x			
	P2	Emergency	x				
<i>Gas Turbines</i>							
Fuel oil	Q1	Pressure or flow – low	x	x			
	Q2	Temperature – high and low (or viscosity – low and high)	x	x			For heavy fuel oil.
Lubricating oil	R1	Inlet pressure – low	x	x	x	x	
	R2	Inlet temperature – high	x	x			
	R3	Bearing temp. or bearing oil outlet temp. – high	x	x			
	R4	Filter differential pressure – high	x				
	R5	Tank level – low	x	x			
Cooling medium	S1	Pressure or flow – low	x	x			
	S2	Temperature – high	x				
Starting	T1	Stored starting energy level – low	x				
	T2	Ignition failure	x			x	
Combustion	U1	Combustion or flame failure	x			x	
Exhaust gas	V1	Temperature – high	x	x		x	
Turbine	W1	Vibration level – high	x			x	
	W2	Rotor axial displacement – large	x			x	Auto shutdown may be omitted for rotors fitted with roller bearings
	W3	Overspeed	x			x	
	W4	Vacuum at compressor inlet – high	x			x	
Power Supply	Z1	Main	x	x			
	Z2	Emergency	x				

Display = display of the analog or digital signal for the monitored parameter. The display of the signal is to provide indication of the monitored parameter in engineering units (such as degrees, PSI, RPM, etc.) or status indication. The engineering unit is to effectively display the relevant information concerning the monitored parameter. An alternative engineering unit which provides equivalent effectiveness, may be considered.

Auto start = automatic starting of a standby pump, along with activation of suitable alarm.

Auto shutdown = automatic stopping of the diesel engines and gas turbine, along with activation of suitable alarm.

TABLE 5A
Instrumentation and Safety System Functions in Centralized Control Station – Propulsion Boiler

System		Monitored Parameters	A	D	Auto Start	Auto Shut down	Notes [A = alarm. D = display. x = apply.]
Sensors		Common/separate	c	c	s	s	c = common sensor; s = separate sensor
Feed water	A1	Atmospheric drain tank level – high and low	x	x			
	A2	Dearator level – high and low	x	x			
	A3	Dearator pressure – high and low	x	x			
	A4	Feed water pump pressure – low	x	x	x		
	A5	Feed water temperature – high	x	x			
	A6	Feed water outlet salinity – high	x	x			
Boiler Drum	B1	Water level – high and low	x	x			
	B2	Water level – low-low	x			x	
Steam	C1	Pressure – high and low	x	x			
	C2	Superheater outlet temperature – high	x	x			
Air	D1	Forced draft pressure – failure	x			x	See 4-9-2/9.3iv)
	D2	Rotating air heater motor – failure	x				If provided
	D3	Air register – open/close		x			
	D4	Fire in boiler casing	x	x			
Fuel oil	E1	Pump pressure at outlet – low	x	x	x		
	E2	Heavy fuel oil temperature – high (or viscosity – low)	x	x			
	E3	Heavy fuel oil temperature – low (or viscosity – high)	x	x			
	E4	Master fuel oil valve – open/close		x			
Burner	F1	Burner valve – open/close		x			Individual
	F2	Atomizing medium pressure – off-limits	x	x			
	F3	Ignition or flame of burners – fails	x	x		x	For multiple burners, flame failure of a single burner is to shut down the corresponding burner fuel valves. Shutdown is to be achieved within 6 seconds following flame extinguishment.
	F4	Flame scanner – fails	x			x	For multiple burners fitted with individual flame scanner, failure of flame scanner is to shut down the corresponding burner fuel valves.
	F5	Uptake gas temperature – high	x				For fire detection
Power	G1	Control system power supply – fails	x	x		x	Automatic closing of fuel valve(s)

Display = display of the analog or digital signal for the monitored parameter. The display of the signal is to provide indication of the monitored parameter in engineering units (such as degrees, PSI, RPM, etc.) or status indication. The engineering unit is to effectively display the relevant information concerning the monitored parameter. An alternative engineering unit which provides equivalent effectiveness, may be considered.

Auto start = automatic starting of standby pump in the system, with activation of suitable alarm.

Auto shutdown = automatic closing of fuel valve, with activation of suitable alarm.

TABLE 5B
Instrumentation and Safety System Functions in Centralized Control Station –
Auxiliary Boiler

System	Monitored Parameters		A	D	Auto Shut down	Notes
						[A = alarm. D = display. x = apply.]
Feedwater	A1	Feedwater outlet salinity – high	x	x		
Boiler drum	A2	Water level – high	x			
	A3	Water level – low	x	x	x	
Steam	A4	Pressure – high and low	x	x		
	A5	Superheater outlet temperature – high	x	x		
Air	A6	Supply air pressure – failure	x		x	See 4-9-2/9.3iv), Alarm for draft fan failure is acceptable
	A7	Fire in boiler air supply casing	x			Excessive high temperature alarm at boiler air supply casing is acceptable
Fuel oil	A8	Pump outlet pressure – low	x	x		
	A9	Temperature – high and low (or viscosity – low and high)	x	x		For heavy fuel oil only
Burner	A10	Fuel oil valves – open/close		x		Individual valves (see Note 1)
	A11	Ignition or flame – fails	x	x	x	Individual; see 4-9-6/Table 5A
	A12	Flame scanner – fails	x		x	Individual; see 4-9-6/Table 5A
	A13	Uptake gas temp. – high	x			
Power	A14	Control system power supply – fails	x		x	

Display = display of the analog or digital signal for the monitored parameter. The display of the signal is to provide indication of the monitored parameter in engineering units (such as degrees, PSI, RPM, etc.) or status indication. The engineering unit is to effectively display the relevant information concerning the monitored parameter. An alternative engineering unit which provides equivalent effectiveness, may be considered.

Notes:

- 1 Applicable only to auxiliary boilers with multiple burners.
- 2 See also 4-9-5/13.11.2 for summary alarms.

TABLE 6
Instrumentation and Safety System Functions in Centralized Control Station –
Auxiliary Turbines and Diesel Engines

System	Monitored System & Parameters		A	D	Auto Shut down	Notes [A = alarm. D = display. x = apply.]	
Diesel Engine	Lubricating oil	A1	Bearing oil inlet pressure – low	x	x	x	
		A2	Bearing inlet oil temperature – high	x	x		
		A3	Oil mist in crankcase, mist concentration – high; or bearing temperature – high; or alternative arrangements	x		x	For engines having a power of 2250 kW (3000 hp) and above or having a cylinder bore more than 300 mm (11.8 in.). Single sensor having two independent outputs for initiating alarm and for shutdown will satisfy independence of alarm and shutdown. See 4-2-1/7.2.
		A4	Common rail servo oil pressure – low	x			
	Cooling medium	A5	Pressure or flow – low	x	x		
		A6	Temperature at outlet – high	x	x		
		A7	Expansion tank level – low	x			
	Fuel oil	A8	Fuel oil leakage from injection pipe	x			
		A9	Fuel oil temp. – high and low (or viscosity – low and high)	x			For heavy fuel oil only
		A10	Service tank level – low	x			
		A11	Common rail fuel oil pressure - low	x			
	Starting medium	A12	Energy level – low	x	x		
	Exhaust	A13	Exhaust gas temperature after each cylinder – high	x			For engines having a power of more than 500 kW/cyl.
	Speed	A14	Overspeed	x		x	
	Turbocharger	A15	High speed	x			Alarm Activation for High Speed only required for turbochargers of categories B and C
Steam Turbine	Lubricating oil	B1	Bearing oil inlet pressure – low	x	x	x	
		B2	Bearing oil inlet temperature – high	x	x		
		B3	Bearing temperature or bearing oil outlet temperature – high	x	x		
	Lub. oil cooling medium	B4	Pressure or flow – low	x	x		
		B5	Temperature at outlet – high	x			
		B6	Expansion tank level – low	x			
	Sea water	B7	Pressure or flow – low	x	x		
	Steam	B8	Pressure at inlet – low	x	x		
	Condensate	B9	Condenser vacuum – low	x	x	x	
		B10	Condensate pump pressure – low	x	x		
	Rotor	B11	Axial displacement – large	x		x	
		B12	Overspeed	x		x	

TABLE 6 (continued)
Instrumentation and Safety System Functions in Centralized Control Station –
Auxiliary Turbines and Diesel Engines

<i>System</i>	<i>Monitored System & Parameters</i>		<i>A</i>	<i>D</i>	<i>Auto Shut down</i>	<i>Notes</i> [<i>A = alarm. D = display. x = apply. </i>]	
Gas Turbine	Lubricating oil	C1	Inlet pressure inlet – low	x	x	x	
		C2	Inlet temperature – high	x	x		
		C3	Bearing temp. or oil outlet temp. – high	x	x		
		C4	Filter differential pressure	x			
	Cooling medium	C5	Pressure or flow – low	x	x		
		C6	Temperature – high	x			
	Fuel oil	C7	Pressure, inlet – low	x	x		
		C8	Temp. – high and low (or viscosity – low and high)	x			For heavy fuel oil only
	Exhaust gas	C9	Temperature – high	x			
	Combustion	C10	Combustion or flame failure	x		x	
	Starting	C11	Ignition failure	x		x	
		C12	Stored starting energy level – low	x			
	Turbine	C13	Vibration level – high	x		x	
		C14	Axial displacement – high	x		x	Auto shutdown may be omitted for rotors fitted with roller bearings
		C15	Overspeed	x		x	
		C16	Vacuum at compressor inlet – high	x		x	

Display = display of the analog or digital signal for the monitored parameter. The display of the signal is to provide indication of the monitored parameter in engineering units (such as degrees, PSI, RPM, etc.) or status indication. The engineering unit is to effectively display the relevant information concerning the monitored parameter. An alternative engineering unit which provides equivalent effectiveness, may be considered.

4

CHAPTER 9 Automation

SECTION 7 Vessels with Compact Propulsion Machinery Spaces

1 ABCU Notation

1.1 General

The requirements in this Section apply to vessels capable of operating as **ACCU** classed vessels but because of their compact propulsion-machinery space design are not fitted with the means to control the propulsion and its associated machinery from a centralized location within the propulsion-machinery space. Except as noted herein, the requirements in Sections 4-9-1, 4-9-2, 4-9-5, 4-9-6, as applicable, are to be complied with.

The notation **ABCU** will be assigned upon verification of compliance and upon satisfactory tests and trials carried out in accordance with the provisions of Section 4-9-10 in the presence of a Surveyor.

1.3 Station in Navigation Bridge

Controls, alarms and displays as listed in 4-9-6/5 are to be provided on the station in the navigation bridge. See 4-9-2/13 and 4-9-2/Table 2. For vessels having nonintegrated propulsion machinery, the means for starting, stopping and transferring vital auxiliary pumps (see 4-9-6/13.5) are to be fitted at the station in the navigation bridge and may also be fitted in the centralized station.

1.5 Centralized Monitoring Station

The requirements in 4-9-6/11 are applicable. The station is to include displays and alarms needed for the monitoring of the propulsion machinery and associated ship's service systems, electrical power generating machinery, and monitoring of propulsion-machinery space. The monitoring system is to provide the same degree of equivalency as if the propulsion-machinery space was manned. See 4-9-6/Table 1 through 4-9-6/Table 4 and 4-9-5/Table 1 for required alarms and displays to be fitted at this station.

1.7 Communications

Communications, as required in 4-9-2/13.15, are also to include the centralized monitoring station in the propulsion-machinery space.

4

CHAPTER 9 Automation

SECTION 8 Special Systems

1 Control and Monitoring of Doors and Hatches

1.1 Application

This section provides requirements for monitoring and control of the doors (watertight bulkhead doors, shell doors and external doors) and hatches, as indicated below.

1.1.1 Sliding Watertight Doors that are Used While at Sea, Meeting the Requirements in 3-2-9/9.1
The requirements in 4-9-8/1.3 are to be complied with.

1.1.2 Watertight Access Doors and Access Hatch Covers, Normally Closed at Sea, Meeting the Requirements in 3-2-9/9.3 and 3-2-15/17.3
The requirements in 4-9-8/1.5 are to be complied with.

1.1.3 Bow Doors, Inner Doors, Side Shell Doors and Stern Doors Meeting the Requirements in 3-2-16/3
The requirements in 4-9-8/1.7 are to be complied with.

1.1.4 External Doors Meeting the Requirements in 3-2-15/17.1 and 3-2-16/1
The requirements in 4-9-8/1.9 are to be complied with.

The requirements for monitoring and control of the doors in passenger vessels are given in 5C-7-5/17.

1.3 Doors Used While at Sea

1.3.1 Control of Doors

Where designed for power operation, doors are to be capable of being remotely closed from the bridge and are also to be operable locally from each side of the bulkhead. Each power-operated sliding door is to be provided with an individual hand-operated mechanism.

Where designed for power operation, a single failure in the electric or hydraulic power-operated system, excluding the hydraulic actuator, is not to prevent the hand operation of any door. Where necessary for power operation of the door, means to start hydraulic unit, or equivalent arrangement, is to be provided at the navigation bridge, and at each remote control position, if provided, and local control position.

1.3.2 Monitoring of Doors

Displays are to be provided at control position showing whether the doors are open or closed.

Display and alarm systems are to be self-monitoring such that any failure in the system (e.g., power failure, sensor failure, etc.) will be detected and alarmed at the navigation bridge control position.

Effective means of testing of monitoring systems are to be provided.

1.3.3 Closing Alarm of Doors

Each power-operated sliding door is to be provided with an audible alarm which will sound whenever the door is closed remotely and which is to sound for at least five seconds but no more than ten seconds before the door begins to move and is to continue sounding until the door is completely closed.

1.3.4 Electrical Power Supply

The electrical power required for power-operated doors is to be supplied from the emergency switchboard either directly or through a distribution board situated above the bulkhead deck. The associated control and monitoring circuits are to be supplied from the emergency switchboard, either directly or through a distribution board situated above the bulkhead deck. The power circuits for power-operated doors are to be separate from power supply to any other systems.

Availability of the power supplies is to be continuously monitored on the load side of the feeder's protective device. Loss of any such power supply is to activate an audible and visual alarm at the navigation bridge control position.

1.3.5 Arrangements of Electric Power, Control and Monitoring Circuits

Electric power, control and monitoring circuits are to be protected against fault in such a way that a failure in one door circuit will not cause a failure in any other door circuits. Short circuits or other faults in alarm or display circuits of a door are not to result in a loss of power operation of that door.

A single electrical failure in the power operating or control system of a power-operated door is not to result in opening of a closed door.

1.3.6 Electrical Equipment

As far as practicable, electrical equipment and components for watertight doors are to be situated above the freeboard deck and outside hazardous areas.

The enclosures of electrical components necessarily situated below the freeboard deck are to provide suitable protection against the ingress of water, as follows:

- Electrical motors, associated circuits and control components: protected to IPX7 standard
- Door position indicators and associated circuit components: protected to IPX8 standard (The water pressure testing of the enclosure is to be based on the pressure that may occur at the location of the component during flooding for a period of 36 hours)
- Door movement warning signals: protected to IPX6 standard

Enclosures of other electrical components are to be in accordance with 4-8-3/Table 2.

1.3.7 Hydraulic System

The hydraulic system is to be in accordance with 4-6-7/3.

The hydraulic system is to be dedicated to the operation of the doors. The system is to be designed such that the possibility of a single failure in the hydraulic piping adversely affecting the operation of more than one door is minimized.

1.5 Access Doors/Hatches Normally Closed at Sea

Doors and hatches fitted with gaskets and dogs are to be provided with means of indicating locally and on the bridge whether they are open or secured closed. For this purpose, all dogs are to be monitored individually. When all dogs are linked to a single acting mechanism, then only the monitoring of a single dog is required.

The power supply to the monitoring system is to be in accordance with 4-9-8/1.3.4 and the monitoring system is to be self-monitoring in accordance with 4-9-8/1.3.2.

1.7 Bow Doors, Inner Doors, Side Shell Doors and Stern Doors

1.7.1 Securing Arrangement

1.7.1(a) Hydraulic Securing Devices. Where hydraulic securing devices are applied, the system is to be mechanically lockable in the closed position. In the event of a loss of hydraulic fluid, the securing devices are to remain locked.

The hydraulic system for securing and locking devices is to be isolated from other hydraulic circuits when in the closed position.

1.7.2 Remote Control

Where bow doors and inner doors give access to a vehicle deck, or where side shell doors or stern doors are located partially or totally below the freeboard deck with a clear opening area greater than 6 m² (65 ft²), an arrangement for remote control from a position above the freeboard deck is to be provided allowing closing and opening of the doors and associated securing and locking of every door. The operating panels for doors are to be accessible to authorized persons only. A notice plate giving instructions to the effect that all securing devices are to be closed and locked before leaving harbor is to be placed at each operating panel and is to be supplemented by warning indicator lights, as required by 4-9-8/1.7.3(b)ii).

1.7.3 Monitoring

1.7.3(a) General. The following requirements for displays, water leakage protection and door surveillance are required for vessels fitted with bow doors and inner doors. The requirements also apply to vessels fitted with side shell doors or stern doors in the boundary of special category spaces or ro-ro spaces through which such spaces may be flooded.

The requirements are not applicable to ro-ro cargo vessels where no part of the side shell doors or stern doors is located below the uppermost waterline and the area of the door opening is not greater than 6 m² (65 ft²).

1.7.3(b) Displays and Alarms. The display system and the alarm system are to be of self-monitoring type and in accordance with the following. Also, the alarm system is to be designed on the fail-safe principle. See 4-9-8/1.7.3(b)v).

i) *Location and Type.* Separate indicator lights are to be provided on the navigation bridge and on each operating panel to show that the doors are closed and that their locking devices are properly positioned.

The display panel on the navigation bridge is to be equipped with a mode selection function "harbor/sea voyage", arranged so that an audible and visible alarm is given on the navigation bridge if, in the sea voyage condition, the doors are not closed or any of the securing devices are not in the correct position. Display of the open/closed position of every door and every securing and locking device is to be provided at the operating panels.

ii) *Indicator Lights.* Indicator lights are to be designed so that they cannot be manually turned off. The display panel is to be provided with a lamp test function.

iii) *Power Supply.* The power supply for the display system is to be independent of the power supply for operating and closing the doors and is to be provided with a back-up power supply from the emergency source of power or other secure power supply (e.g., UPS).

iv) *Protection of Sensors.* Sensors are to be protected from water, ice formation and mechanical damage.

v) *Fail Safe Principle.* The alarm/indicator system is considered designed on a fail-safe principle when the following are provided, as applicable.

1) The indicator panel is provided with:

- A power failure alarm
- An earth failure alarm
- A lamp test
- Separate indication for door closed, door locked, door not closed and door not locked.

2) Limit switches electrically closed when the door is closed (when more limit switches are provided, they may be connected in series)

3) Limit switches electrically closed when securing arrangements are in place (when more limit switches are provided, they may be connected in series)

- 4) Two electrical circuits (also in one multicore cable), one for the indication of door closed/not closed and the other for door locked/not locked.
- 5) In the case of dislocation of limit switches, indication to show: not closed/not locked/securing arrangements not in place, as appropriate.

1.7.4 Leakage Monitoring

1.7.4(a) Bow Doors and Inner Doors. For vessels fitted with bow and inner doors, a water leakage detection system with audible alarm and television surveillance is to be arranged to provide an indication to the navigation bridge and to the engine control room of leakage through the inner door. See 4-9-8/1.7.3(b)v).

1.7.4(b) Side Shell Doors and Stern Doors. For passenger vessels fitted with side shell or stern doors, a water leakage detection system with audible alarm and television surveillance is to be arranged to provide an indication to the navigation bridge and to the engine control room of leakage through any of the doors.

For cargo vessels fitted with side shell or stern doors, a water leakage detection system with audible alarm is to be arranged to provide an indication to the navigation bridge of leakage through any of the doors. See 4-9-8/1.7.3(b)v).

1.7.4(c) Drainage. A drainage system is to be arranged in the area between the bow door and ramp or where no ramp is fitted between the bow door and inner door. The system is to be equipped with an audible alarm function to the navigation bridge being set off when the water levels in these areas exceed 0.5 m (1.6 ft) or the high water level alarm, whichever is the lesser. See 4-9-8/1.7.3(b)v).

1.7.5 Door Surveillance

Between the bow door and the inner door, a television surveillance system is to be fitted with a monitor on the navigation bridge and in the engine control room. The system is to monitor the position of doors and a sufficient number of their securing devices. Special consideration is to be given for the lighting and contrasting color of objects under surveillance.

1.7.6 Electrical Equipment

Electrical equipment are to comply with 4-9-8/1.3.6.

1.7.7 Hydraulic System

Hydraulic system is to comply with 4-9-8/1.3.7.

1.9 External Doors/Openings

1.9.1 External Openings Below Damaged Waterline

External openings meeting the requirements in 3-2-15/17.1 are to be fitted with displays on the navigation bridge showing whether the closing appliances are open or secured closed.

For the openings fitted with gaskets and dogs, all dogs are to be monitored individually. When all dogs are linked to a single acting mechanism, then only the monitoring of a single dog is required.

The power supply to the monitoring system is to be in accordance with 4-9-8/1.3.4 and the monitoring system is to be self-monitoring in accordance with 4-9-8/1.3.2.

1.9.2 Cargo, Gangway or Fueling Ports

The ports in the side shell below the freeboard or superstructure deck are to be fitted with displays on the navigation bridge showing whether the closing appliances are open or secured closed.

For ports fitted with gaskets and dogs, all dogs are to be monitored individually. When all dogs are linked to a single acting mechanism, then only the monitoring of a single dog is required.

For the compartment between the port and the second door, if provided, a water leakage detection system with audible alarm is to be arranged to provide an indication to the navigation bridge of leakage through any of the doors.

The power supply to the monitoring system is to be in accordance with 4-9-8/1.3.4 and the monitoring system is to be self-monitoring in accordance with 4-9-8/1.3.2.

4

CHAPTER 9 Automation

SECTION 9 Equipment

1 Application

The requirements of 4-9-9/1 through 4-9-9/13 apply to equipment that are components of the control, monitoring and safety systems of propulsion machinery, propulsion boilers, vital auxiliary pumps and the electrical power generating plant including its prime mover for vessels to be assigned with **ACC**, **ACCU** or **ABCU** notation.

Remote propulsion controls fitted on vessels not receiving notations are to be in accordance with 4-9-9/15.

3 Environmental Test Conditions

Control, safety and monitoring equipment is to be designed such that it will successfully withstand the test conditions stipulated in 4-9-9/Table 1, as applicable.

Upon request by the manufacturer, equipment designed to environmental conditions in excess of those in 4-9-9/Table 1 may be tested to such conditions and certified accordingly.

5 Environmentally Controlled Space

Where equipment is designed to operate only in a temperature-regulated environment, the temperature regulating system (such as air-conditioner) is to be backed up by a stand-by unit. Failure of the system is to be alarmed.

7 Electric and Electronic Equipment

Electric and electronic equipment that are components of control, safety and monitoring systems are to be designed and constructed in accordance with the provisions of Section 4-8-3, and specifically as follows:

Material design	as per 4-8-3/1.7
Electrical characteristics	as per 4-8-3/1.9
Enclosures	as per 4-8-3/1.11
Accessibility	as per 4-8-3/1.13
Insulation material	as per 4-8-3/1.15
Wiring and cables	as per 4-8-3/5.3.6 and 4-8-3/9

9 Hydraulic Equipment

Hydraulic equipment is to be suitable for the intended service, compatible with the working fluid and is to be in accordance with the provisions of 4-6-7/3. The hydraulic fluid is to be non-flammable or have a flash point above 157°C (315°F).

11 Pneumatic Equipment

Pneumatic equipment is to be suitable for the intended service and is to be in accordance with the provisions of 4-6-7/5.

13 Equipment Tests

13.1 Prototype Environmental Testing

The following tests are to be carried out as a prototype testing in the presence of the Surveyor:

- i) Power supply variation test (item 1 in 4-9-9/Table 1)
- ii) Vibration test (item 5 in 4-9-9/Table 1)
- iii) Inclination test (item 6 in 4-9-9/Table 1)

Other prototype environmental tests specified in 4-9-9/Table 1 are to be conducted by the manufacturers; acceptance will be based on review of manufacturer's certified test reports by ABS. Omission of certain tests may be considered, taking into consideration the location of installation, functionality, contained devices, etc. of the equipment.

In general, field sensors (e.g., pressure transmitters) and field devices (e.g., solenoid valves), circuit breakers and cables may be exempted from tests specified in 4-9-9/Table 1.

For computer-based systems, the equipment to be tested includes microprocessors, storage devices, power supply units, signal conditioners, analog/digital converters, computer monitors (visual display units), keyboards, etc. but may exclude printer, data recording or logging device not required in this section.

13.3 Production Unit Certification

After assembled to a complete assembly unit or subassembly unit, each production unit of equipment used in control, monitoring and safety systems is to be tested at the manufacturer's shop in the presence of the Surveyor to verify the tests in 4-9-9/Table 2.

13.5 Type Approval Program

Refer to 4-1-1/3.3 of the *Marine Vessel Rules*.

15 Equipment

Remote propulsion controls fitted on vessels not receiving notations are to be in accordance with the following requirements.

15.1 Electrical Equipment

The requirements in 4-9-9/7 are applicable.

15.3 Computer Based Equipment

Requirements in Section 4-9-3 are applicable. Equipment type tests in 4-9-3/13.3, duplication of equipment and duplication of data links in integrated systems in 4-9-3/5.3 and duplication of monitor in centralized control station in 4-9-3/11.5 are not applicable.

15.5 Hydraulic and Pneumatic Equipment

The requirements of 4-9-9/9 and 4-9-9/11 are applicable in general. However, flash point limitation on hydraulic fluids is applicable only to vessels to be assigned with **ACC**, **ACCU**, or **ABCU** notations.

15.7 Acceptance Tests

All equipment is to be performance tested in the presence of a Surveyor in accordance with 4-9-9/Table 2 either in the shop or after installation. All installations are to be functionally tested to the satisfaction of the surveyor on board and during sea trials, see Section 4-9-10.

TABLE 1
Type Tests for Control, Monitoring and Safety Equipment

No	TEST	PROCEDURE ACCORDING TO: [See Note 7]	TEST PARAMETERS	OTHER INFORMATION																														
1.	Power supply variations (a) electric	---	<p style="text-align: center;"><i>AC Supply</i></p> <table border="1" style="width: 100%; border-collapse: collapse;"> <thead> <tr> <th style="width: 33%;">Combination</th> <th style="width: 33%;">Voltage variation permanent (%)</th> <th style="width: 33%;">Frequency variation permanent (%)</th> </tr> </thead> <tbody> <tr><td style="text-align: center;">1</td><td style="text-align: center;">+ 6</td><td style="text-align: center;">+ 5</td></tr> <tr><td style="text-align: center;">2</td><td style="text-align: center;">+ 6</td><td style="text-align: center;">- 5</td></tr> <tr><td style="text-align: center;">3</td><td style="text-align: center;">- 10</td><td style="text-align: center;">- 5</td></tr> <tr><td style="text-align: center;">4</td><td style="text-align: center;">- 10</td><td style="text-align: center;">+ 5</td></tr> </tbody> </table> <table border="1" style="width: 100%; border-collapse: collapse;"> <thead> <tr> <th style="width: 33%;">Combination</th> <th style="width: 33%;">Voltage transient 1.5 s (%)</th> <th style="width: 33%;">Frequency transient 5 s (%)</th> </tr> </thead> <tbody> <tr><td style="text-align: center;">5</td><td style="text-align: center;">+ 20</td><td style="text-align: center;">+ 10</td></tr> <tr><td style="text-align: center;">6</td><td style="text-align: center;">- 20</td><td style="text-align: center;">- 10</td></tr> </tbody> </table> <p style="text-align: center;"><i>DC Supply</i></p> <table border="1" style="width: 100%; border-collapse: collapse;"> <tbody> <tr><td style="width: 66%;">Voltage tolerance continuous</td><td style="text-align: center;">± 10%</td></tr> <tr><td style="width: 66%;">Voltage cyclic variation</td><td style="text-align: center;">5 %</td></tr> <tr><td style="width: 66%;">Voltage ripple</td><td style="text-align: center;">10%</td></tr> </tbody> </table> <p><i>Electric battery supply:</i> +30% to -25% for equipment connected to charging battery or as determined by the charging / discharging characteristics, including ripple voltage from the charging device; +20% to -25% for equipment not connected to the battery during charging</p>	Combination	Voltage variation permanent (%)	Frequency variation permanent (%)	1	+ 6	+ 5	2	+ 6	- 5	3	- 10	- 5	4	- 10	+ 5	Combination	Voltage transient 1.5 s (%)	Frequency transient 5 s (%)	5	+ 20	+ 10	6	- 20	- 10	Voltage tolerance continuous	± 10%	Voltage cyclic variation	5 %	Voltage ripple	10%	
Combination	Voltage variation permanent (%)	Frequency variation permanent (%)																																
1	+ 6	+ 5																																
2	+ 6	- 5																																
3	- 10	- 5																																
4	- 10	+ 5																																
Combination	Voltage transient 1.5 s (%)	Frequency transient 5 s (%)																																
5	+ 20	+ 10																																
6	- 20	- 10																																
Voltage tolerance continuous	± 10%																																	
Voltage cyclic variation	5 %																																	
Voltage ripple	10%																																	
2.	Power supply variations (Continued) (b) Pneumatic and hydraulic	---	Pressure: ± 20% Duration: 15 minutes																															
3.	Dry heat	IEC 60068-2-2	Temperature: 55°C (131°F) ± 2°C (3.6°F) Duration: 16 hours Or Temperature: 70°C (158°F) ± 2°C (3.6°F) Duration: 16 hours [See Note 1]	Equipment operating during conditioning and testing; Functional test during the last hour at the test temperature. For equipment specified for increased temperature the dry heat test is to be conducted at the agreed test temperature and duration.																														
3A.	Dry heat – Higher Temp (see Note 8) (Optional Test)	IEC 60068-2-2	Temperature: 70°C (158°F) ± 2°C (3.6°F) Duration: 16 hours [See Note 8]	Equipment operating during conditioning and testing; Functional test during the last hour at the test temperature;																														

TABLE 1 (continued)
Type Tests for Control, Monitoring and Safety Equipment

No	TEST	PROCEDURE ACCORDING TO: [See Note 7]	TEST PARAMETERS	OTHER INFORMATION
4.	Damp heat	IEC 60068-2-30 - Test Db	Temperature: 55°C (131°F) Humidity: 95% Duration: 2 cycles 2 x (12 + 12 hours)	Measurement of insulation resistance before test; The test shall start with 25°C ± 3°C and at least 95% humidity; Equipment operating during the complete first cycle and switched off during second cycle, except for functional test; Functional test during the first 2 hours of the first cycle at the test temperature and during the last 2 hours of the second cycle at the test temperature. Duration of the second cycle can be extended due to more convenient handling of the functional test. Recovery at standard atmosphere conditions; Insulation resistance measurements and performance test.
5.	Vibration	IEC 60068-2-6, Test Fc	2.0 (+3/-0) Hz to 13.2 Hz – amplitude ±1 mm (0.039 in.) 13.2 Hz to 100 Hz – acceleration ±0.7 g For severe vibration conditions, e.g., on diesel engines, air compressors, etc.: 2.0 Hz to 25 Hz – amplitude ±1.6 mm (0.063 in.) 25.0 Hz to 100 Hz – acceleration ±4.0 g <i>Note:</i> <i>More severe conditions may exist for example on exhaust manifolds or fuel oil injection systems of diesel engines. For equipment specified for increased vibration levels, the vibration test is to be conducted at the agreed vibration level, frequency range and duration.</i> <i>Values may be required to be in these cases</i> <i>40 Hz to 2000 Hz – acceleration ± 10.0g at 600 °C duration 90 min.</i>	Duration: 90 minutes at 30 Hz in case of no resonance conditions; Duration: 90 minutes for each resonance frequency at which $Q \geq 2$ is recorded; During the vibration test, functional tests are to be carried out; Tests to be carried out in three mutually perpendicular planes; It is recommended as guidance that Q does not exceed 5; Where sweep test is to be carried out instead of the discrete frequency test and a number of resonant frequencies are detected close to each other duration of the test is to be 120 min. Sweep over a restricted frequency range between 0.8 and 1.2 times the critical frequencies can be used where appropriate. <i>Note: Critical frequency is a frequency at which the equipment being tested may exhibit:</i> <ul style="list-style-type: none"> • malfunction and/or performance deterioration • mechanical resonances and/or other response effects occur, for example, chatter

TABLE 1 (continued)
Type Tests for Control, Monitoring and Safety Equipment

No	TEST	PROCEDURE ACCORDING TO: [See Note 7]	TEST PARAMETERS				OTHER INFORMATION		
6.	Inclination	IEC 60092-504	Static 22.5°				a) Inclined at an angle of at least 22.5° to the vertical; b) Inclined to an angle of at least 22.5° on the other side of the vertical and in the same plane as in (a); c) Inclined to an angle of at least 22.5° to the vertical and in plane at right angles to that used in (a); d) Inclined to an angle of at least 22.5° on the other side of the vertical and in the same plane as in (c) <i>Note: The duration of testing in each position should be sufficient to fully evaluate the behavior of the equipment.</i>		
			Dynamic 22.5°				Using the directions defined in a) to d) above, the equipment is to be rolled to an angle of 22.5° each side of the vertical with a period of 10 seconds. The test in each direction is to be carried out for not less than 15 minutes <i>Note: These inclination tests are normally not required for equipment with no moving parts.</i>		
7.	Insulation resistance	---	Rated supply voltage (V)	Test voltage (DC voltage) (V)	Min. Insulation Resistance		Insulation resistance test is to be carried out before and after: damp heat test, cold test, salt mist test, and high voltage test; <ul style="list-style-type: none"> • between all phases and earth; • and where appropriate, between the phases. <i>U_n</i> is the rated (nominal) voltage. <i>Note: Certain components e.g., for EMC protection may be required to be disconnected for this test. For high voltage equipment, reference is made to 4-8-5/3.</i>		
			$U_n \leq 65$	$2 \times U_n$ (min. 24 V)	Before test (MΩ)	After test (MΩ)		10	1.0
			$U_n > 65$	500	100	10			

TABLE 1 (continued)
Type Tests for Control, Monitoring and Safety Equipment

No	TEST	PROCEDURE ACCORDING TO: [See Note 7]	TEST PARAMETERS		OTHER INFORMATION
8.	High voltage	---	Rated voltage U_n (V) Up to 65 66 to 250 251 to 500 501 to 690	Test voltage [AC voltage 50 or 60 Hz] (V) $2 \times U_n + 500$ 1500 2000 2500	Separate circuits are to be tested against each other and all circuits connected with each other tested against earth; Printed circuits with electronic components may be removed during the test; Period of application of the test voltage: 1 minute
9.	Cold	IEC 60068-2-1	Temperature: +5°C (41°F) ± 3°C (5.4°F) Duration: 2 hours Or Temperature: -25°C (-13°F) ± 3°C (5.4°F) Duration: 2 hours [See Note 2]		Initial measurement of insulation resistance; Equipment not operating during conditioning and testing, except for functional test; Functional test during the last hour at the test temperature; Insulation resistance measurement and the functional test after recovery.
10.	Salt mist	IEC 60068-2-52 Test Kb	Four spraying periods with a storage of 7 days after each.		Initial measurement of insulation resistance and initial functional test; Equipment not operating during conditioning of the test specimen; Functional test on the 7 th day of each storage period; Insulation resistance measurement and performance test: 4 to 6 hours after recovery [See Note 3] On completion of exposure, the equipment shall be examined to verify that deterioration or corrosion (if any) is superficial in nature.
11.	Electrostatic discharge	IEC 61000-4-2	Contact discharge: 6 kV Air discharge: 2 kV, 4 kV, 8 kV Interval between single discharges: 1 sec. Number of pulses: 10 per polarity According to test level 3.		To simulate electrostatic discharge as may occur when persons touch the appliance; The test is to be confined to the points and surfaces that can normally be reached by the operator; Performance Criterion B [See Note 4].

TABLE 1 (continued)
Type Tests for Control, Monitoring and Safety Equipment

No	TEST	PROCEDURE ACCORDING TO: [See Note 7]	TEST PARAMETERS	OTHER INFORMATION
12.	Electro-magnetic field	IEC 61000-4-3	<p>Frequency range: 80 MHz to 2 GHz Modulation*: 80% AM at 1000 Hz Field strength: 10 V/m</p> <p>Frequency sweep rate: $\leq 1.5 \times 10^{-3}$ decades/s (or 1% / 3 sec) According to test level 3.</p>	<p>To simulate electromagnetic fields radiated by different transmitters;</p> <p>The test is to be confined to the appliances exposed to direct radiation by transmitters at their place of installation.</p> <p>Performance criterion A [See Note 5]</p> <p>* If for tests of equipment, an input signal with a modulation frequency of 1000 Hz is necessary, a modulation frequency of 400 Hz may be chosen.</p>
13	Conducted Low Frequency		<p>AC: Frequency range: rated frequency to 200th harmonic; Test voltage (rms): 10% of supply to 15th harmonic reducing to 1% at 100th harmonic and maintain this level to the 200th harmonic, minimum 3 V (rms), maximum 2 W</p> <p>DC: Frequency range: 50 Hz – 10 kHz; Test voltage (rms): 10% of supply, maximum 2 W</p>	<p>To simulate distortions in the power supply system generated for instance, by electronic consumers and coupled in as harmonics;</p> <p>Performance criterion A [See Note 5]</p> <p>See 4-9-9/Figure 1 for test set-up. For keeping max. 2 W, the voltage of the test signal may be lower.</p>
14.	Conducted Radio Frequency	IEC 61000-4-6	<p>AC, DC, I/O ports and signal/control lines: Frequency range: 150 kHz – 80 MHz Amplitude: 3 V rms [See Note 6] Modulation **: 80% AM at 1000 Hz Frequency sweep range: $\leq 1.5 \times 10^{-3}$ decades/sec. (or 1% / 3 sec.) According to test level 2.</p>	<p>Equipment design and the choice of materials are to simulate electromagnetic fields coupled as high frequency into the test specimen via the connecting lines.</p> <p>Performance criterion A [See Note 5].</p> <p>** If for tests of equipment, an input signal with a modulation frequency of 1000 Hz is necessary, a modulation frequency of 400 Hz should be chosen.</p>
15.	Electrical Fast Transients/Burst	IEC 61000-4-4	<p>Single pulse rise time: 5ns (between 10% and 90% value) Single pulse width: 50 ns (50% value) Amplitude (peak): 2 kV line on power supply port/earth; 1kV on I/O data control and communication ports (coupling clamp); Pulse period: 300 ms; Burst duration: 15 ms; Duration/polarity: 5 min According to test level 3.</p>	<p>Arcs generated when actuating electrical contacts;</p> <p>Interface effect occurring on the power supply, as well as at the external wiring of the test specimen;</p> <p>Performance criterion B [See Note 4].</p>

TABLE 1 (continued)
Type Tests for Control, Monitoring and Safety Equipment

No	TEST	PROCEDURE ACCORDING TO: [See Note 7]	TEST PARAMETERS	OTHER INFORMATION
16.	Surge	IEC 61000-4-5	Test applicable to AC and DC power ports Open-circuit voltage: Pulse rise time: 1.2 μ s (front time) Pulse width: 50 μ s (time to half value) Amplitude (peak): 1 kV line/earth; 0.5 kV line/line Short-circuit current: Pulse rise time: 8 μ s (front time) Pulse width: 20 μ s (time to half value) Repetition rate: \geq 1 pulse/min Number of pulses: 5 per polarity Application: continuous According to test level 2.	Interference generated for instance, by switching "ON" or "OFF" high power inductive consumers; Test procedure in accordance with figure 10 of the standard for equipment where power and signal lines are identical; Performance criterion B [See Note 4].
17.	Radiated Emission	CISPR 16-2-3	For equipment installed in the bridge and deck zone: Frequency range: Quasi peak Limits: 0.15 – 0.3 MHz 80 – 52 dB μ V/m 0.3 – 30 MHz 52 – 34 dB μ V/m 30 – 2000 MHz 54 dB μ V/m except for: 156 – 165 MHz 24 dB μ V/m For equipment installed in the general power distribution zone: Frequency range: Quasi peak Limits: 0.15 – 30 MHz 80 – 50 dB μ V/m 30 – 100 MHz 60 – 54 dB μ V/m 100 – 2000 MHz 54 dB μ V/m except for: 156 – 165 MHz 24 dB μ V/m	Procedure in accordance with the standard but distance 3 m (10 ft) between equipment and antenna Alternatively, the radiation limit at a distance of 3 m from the enclosure port over the frequency 156 MHz to 165 MHz shall be 30 dB micro-V/m peak.
18.	Conducted Emission	CISPR 16-2-1	Test applicable to AC and DC power ports For equipment installed in the bridge and deck zone: Frequency range: Limits: 10 – 150kHz 96 – 50 dB μ V 150 – 350 kHz 60 – 50 dB μ V 350 kHz – 30 MHz 50 dB μ V For equipment installed in the general power distribution zone: Frequency range: Limits: 10 – 150 kHz 120 – 69 dB μ V 150 – 500 kHz 79 dB μ V 0.5 – 30 MHz 73 dB μ V	

TABLE 1 (continued)
Type Tests for Control, Monitoring and Safety Equipment

<i>No</i>	<i>TEST</i>	<i>PROCEDURE ACCORDING TO: [See Note 7]</i>	<i>TEST PARAMETERS</i>	<i>OTHER INFORMATION</i>
19.	Flame retardant	IEC 60092-101 or IEC 60695-11-5	<p>Flame application: 5 times 15 sec each. Interval between each application: 15 sec. or 1 time 30 sec.</p> <p>Test criteria based upon application.</p> <p>The test is performed with the Equipment Under Test (EUT) or housing of the EUT applying needle-flame test method.</p>	<p>The burnt out or damaged part of the specimen by not more than 60 mm long.</p> <p>No flame, no incandescence or in the event of a flame or incandescence being present, it shall extinguish itself within 30 sec. of the removal of the needle flame without full combustion of the test specimen.</p> <p>Any dripping material shall extinguish itself in such a way as not to ignite a wrapping tissue.</p> <p>The drip height is 200 mm ± 5 mm.</p>

Notes:

- 1 Equipment to be mounted in consoles, housing, etc. together with other equipment are to be tested with 70°C (158°F).
- 2 For equipment installed in non-weather protected locations or cold locations, test is to be carried out at -25°C (-13°F).
- 3 Salt mist test is to be carried out for equipment installed in weather exposed areas.
- 4 Performance criterion B (for transient phenomena): The equipment under test is to continue to operate as intended after the tests. No degradation of performance or loss of function is allowed as defined in the technical specification published by the manufacturer. During the test, degradation or loss of function or performance which is self-recoverable is, however, allowed but no change of actual operating state or stored data is allowed.
- 5 Performance criterion A (for continuous phenomena): The equipment under test is to continue to operate as intended during and after test. No degradation of performance or loss is allowed as defined in relevant equipment standard and the technical specification published by the manufacturer.
- 6 For equipment installed on the bridge and deck zone, the test levels are to be increased to 10 V rms for spot frequencies, in accordance with IEC 60945 at 2, 3, 4, 6.2, 8.2, 12.6, 16.5, 18.8, 22, 25 MHz.
- 7 Alternative equivalent testing procedures may be accepted, provided the requirements in the other columns are complied with.
- 8 When requested, equipment which has undergone the higher temperature and duration test will be recognized accordingly in the PDA certificate (see Appendix 1-1-A3). The purpose of introducing the optional 3HT test is for the convenience of equipment manufacturers should their clients request evidence that the equipment has been tested to the higher temperature requirements noted in Item 3A of the Table.
- 9 As used in this document, and in contrast to a complete performance test, a functional test is a simplified test sufficient to verify that the EUT has not suffered any deterioration caused by the individual environmental tests.

FIGURE 1
Test Set-up for Conducted Low Frequency Test
 (See Test No. 13 of 4-9-9/Table 1)

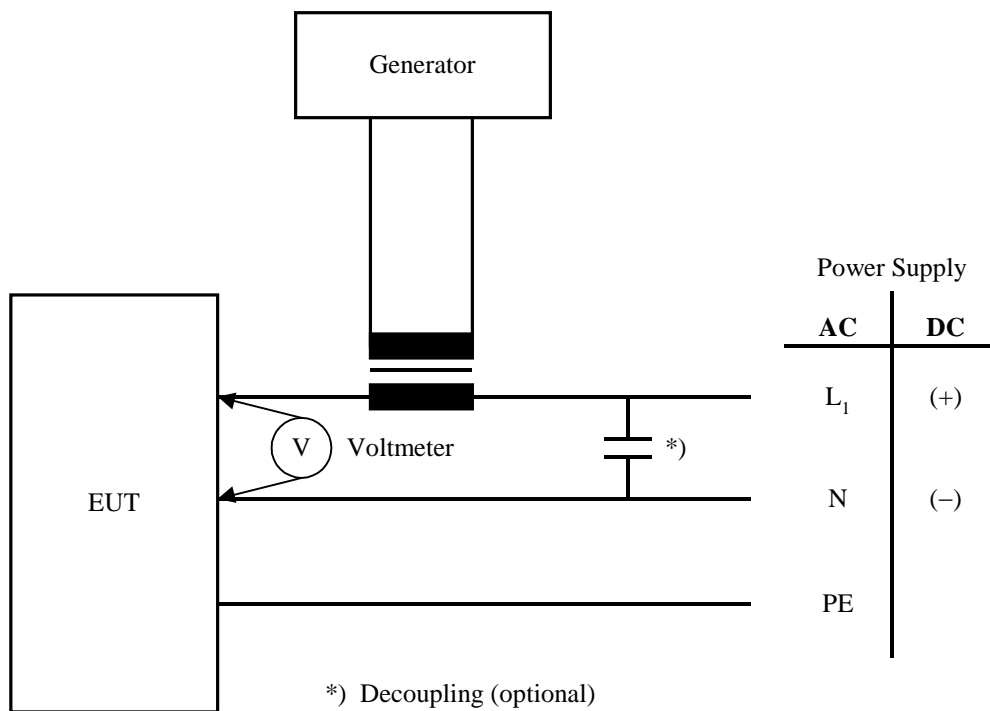

TABLE 2
Tests for Unit Certification of Control, Monitoring and Safety Equipment

<i>No</i>	<i>TEST</i>	<i>PROCEDURE ACCORDING TO: [See Note]</i>	<i>TEST PARAMETERS</i>	<i>OTHER INFORMATION</i>
1.	Visual inspection	---	---	Conformance to drawings, design data Quality of workmanship and construction
2.	Performance test	<p>Manufacturer's performance test program based upon specification and relevant Rule requirements.</p> <p>When the EUT is required to comply with an international performance standard (e.g., protection relays), verification of requirements in the standard are to be part of the performance testing required in this initial test and subsequent performance tests after environmental testing where required by 4-9-9/ Table 1.</p>	<p>Standard atmosphere conditions</p> <p>Temperature: 25°C (77°F) ± 10°C (18°F)</p> <p>Relative humidity: 60% ± 30%</p> <p>Air pressure: 96 kPa (0.98 kgf/cm², 13.92 psi) ± 10 kPa (0.10 kgf/cm², 1.45 psi)</p>	<p>Confirmation that operation is in accordance with the requirements specified for particular system or equipment;</p> <p>Checking of self-monitoring features;</p> <p>Checking of specified protection against an access to the memory;</p> <p>Checking against effect of unerroneous use of control elements in the case of computer systems.</p>
3.	External Power supply failure	---	3 interruptions during 5 minutes; switching-off time 30 s each case	<p>The time of 5 minutes may be exceeded if the equipment under test (EUT) needs a longer time for startup, for example, booting sequence.</p> <p>For equipment which requires booting, one additional power supply interruption during booting is to be performed.</p> <p>Verification of:</p> <ul style="list-style-type: none"> the specified action of equipment upon loss and restoration of supply; possible corruption of program or data held in programmable electronic systems, where applicable.

Note: Alternative equivalent testing procedures may be accepted, provided the requirements in the other columns are complied with.

4

CHAPTER 9 Automation

SECTION 10 Installation, Tests and Trials

1 General

Control equipment and instrumentation are to be so placed or protected as to minimize the likelihood of sustaining damage from the accumulation of dust, oil vapors, steam or dripping liquids, or from activities around their location.

3 Equipment Arrangements and Installation

3.1 Ranges in Ambient Temperatures

For the selection and installation of equipment associated with control and monitoring systems, a temperature range of 5°C (41°F) to 55°C (131°F) is to be considered for machinery space, control rooms, accommodations and navigation bridge. When equipment is located inside panels or cubicles, consideration is to be given to the temperature rise inside those panels due to the dissipation of heat from its own components. See also 4-9-9/Table 1, Note 1.

Where compliance with the above temperature ranges cannot be met, consideration will be given to the installation of equipment per 4-9-9/3.11.

3.3 Electromagnetic Avoidance

In general, the installation of equipment associated with automatic or remote control and monitoring systems in areas of unusual electromagnetic sources is to be avoided. Where the values per 4-9-9/Table 1 may be exceeded, appropriate measures are to be implemented to reduce the effects of electromagnetic and conducted interference. Description of the preventive measures to be followed is to be submitted for review.

3.5 Moisture Condensation

Installation of equipment in locations where ambient temperature fluctuations can lead to accumulation of moisture condensation inside equipment enclosure is to be avoided unless the equipment is protected by, for instance, space heaters, or such equipment is to be designed and constructed to function in this environment.

3.7 Signal Cables Installation

To avoid electromagnetic noise caused by circulating currents, the conductive shield and cable armor is to be grounded only at one end of the cable.

To avoid possible signal interference, signal cables occupying the same cable tray, trunk or conduit with power cables are to be effectively shielded.

3.9 Electrical Grounding

Automatic or remote control and monitoring systems are not to have common earth conductors with systems of higher voltage level.

3.11 Harsh Environment

Electrical equipment which may be adversely affected by the exposure to temperatures lower than those for which they are designed are to be provided with suitable heating arrangements so that they may be readily operated when needed. See 4-9-10/3.1.

3.13 Protection Against Falling Liquids or Leakage of Fluid Medium

Electrical equipment is not to be installed in the same compartment or cabinet containing equipment or pipes carrying water, oil or steam unless effective measures are taken in order to protect the electrical equipment from possible fluid leakage (i.e., welded connections, physical isolation together with suitable draining arrangements, etc.).

3.15 Measuring and Sensing Devices

The installation of measuring and sensing elements is to permit their easy access for functional testing or replacement.

3.17 Marking

All units, controllers, actuators, displays, terminal strips, cable and test points, etc., are to be clearly and permanently marked. Their systems and system's functions are to be included so that they can be easily identified in associated drawings and instrument lists.

5 Sea Trials and Dockside Trials

During sea trial, or dockside trials, as applicable, the following tests, as appropriate, are to be carried out to the satisfaction of the Surveyor.

5.1 Propulsion Remote Control

5.1.1 Control Functions

The ability to effectively control the propulsion from the remote propulsion control station is to be demonstrated during sea trials, or at dockside. These trials are to include:

- Propulsion control transfer
- Propulsion starting
- Verification of propulsion control responses
- Response to propulsion control power failure
- Automatic propulsion shutdown
- Automatic propulsion slowdown
- Actuation of propulsion emergency stop devices
- For turbine-driven vessel, actuation of the shaft turning device

5.1.2 Throttle Response

Response of propulsion machinery to throttle control demands is to be tested during sea-trial to demonstrate that no part of the plant or engine is jeopardized by the rate at which the throttle is moved from one extreme position to the other.

5.3 Local Manual Control

5.3.1 Propulsion Machinery

Independent manual local control of the propulsion machinery is to be demonstrated during trials. This is to include demonstration of independent manual control through the full maneuvering range and transfer from automatic control.

5.3.2 Propulsion Boiler

Independent manual local control of the boilers is to be demonstrated during the tests or trial to the satisfaction of the Surveyor. This is to include demonstration of independent manual control through the full maneuvering range and transfer from automatic control.

5.5 Vessels Receiving ACC Notation

In addition to the tests required in 4-9-10/5.1 and 4-9-10/5.3, vessels with a centralized control station are to be tested, as follows, during sea trial or during the dock trial as appropriate.

After the propulsion machinery has been running for at least two (2) hours, the machinery is to be operated over its full range of power to demonstrate the adequacy of all control systems. The propulsion machinery is to be run for at least an additional four (4) hours, for a total minimum of six (6) hours duration. The following tests are to be included:

- All alarm points and displays
- Operations of automatic controlled machinery
- Transfer of standby auxiliary
- Remote control of auxiliary machinery
- Fire detection system
- Bilge alarm

5.7 Vessels Receiving ACCU Notation

In addition to the tests required in 4-9-10/5.1, 4-9-10/5.3 and 4-9-10/5.5, vessels intended to be operated with periodically unattended machinery space are to be tested, as follows.

5.7.1 Loss of Generator Tests

The loss of electric power (see 4-9-6/15.1) is to be simulated with the main engine running and simulated loss of generator to test:

- Automatic restoration of electric power by standby generator(s);
- Automatic starting of vital auxiliaries; and
- Starting and restoration of control of propulsion prime mover from the centralized control station or the navigation bridge, as appropriate.

5.7.2 Fire Fighting Control Function Tests

All controls provided at the fire fighting station (4-9-6/21.3) are to be functionally tested.

5.7.3 Full Functional Test

After the propulsion machinery has been running for at least two (2) hours, the machinery is to be operated over its full range of power to demonstrate the adequacy of all control systems. The propulsion machinery is to be run for at least four (4) more hours; in total a minimum duration of six (6) hours. During this period, the ability to control the machinery functions correctly for all loads and engine maneuvers without any manual intervention in the propulsion machinery space for four (4) hours is to be demonstrated.

5.9 Vessels Receiving ABCU Notation

In addition to the trials per 4-9-7/5.7, successful operation of the propulsion machinery is to be demonstrated with the propulsion-machinery space unattended for a period of at least 12 hours.

4

CHAPTER 9 Automation

SECTION 11 Vessels Less Than 500 GT Having a Length Equal to or Greater Than 20 m (65 ft)

1 General

The requirements contained in this Section are intended for vessels less than 500 GT having a length equal to or greater than 20 m (65 ft). Vessels having a length less than 20 m (65 ft) will be specially considered.

Note: **ACCU** or **ABCU** class notation may be granted to vessels of < 500 GT and a length of 20 m (65 ft) $\leq l \leq 46$ m (150 ft), provided that the applicable requirements in Sections 4-9-1, 4-9-2, 4-9-5, 4-9-6 and 4-9-10 are met.

3 Definitions

See 4-9-1/5.

5 Plans to be Submitted

Plans and specifications are to be submitted in accordance with 4-9-1/7 for approval and are to include the following information.

- i) Machinery arrangement plans showing location of control stations in relation to controlled units;
- ii) Arrangements and details of control consoles, including front views, installation arrangements together with schematic diagrams for all power, control and monitoring systems, including their functions; and a list of alarms/displays, as required in 4-9-11/15.5.
- iii) Type and size of all electrical cables and wiring associated with the control systems, including voltage rating, service voltage and currents together with overload and short-circuit protection;
- iv) Description of all alarm and emergency tripping arrangements; functional sketches or description of all special valves, actuators, sensors and relays;
- v) Schematic plans and supporting data of fire-protection and extinguishing systems, including fire-detection and alarm systems and bilge high water alarms.
- vi) Schematic plans of hydraulic or pneumatic control systems.

7 Electrical Cables and Console Wiring

In general, cables are to be used external to the consoles and they are to be of the marine type in accordance with the applicable parts of Part 4, Chapter 8. Cables in accordance with other standards which are not less effective will be considered. Cables and console wiring for control and monitoring are to be of the flame-retarding type and are to be stranded, except that solid conductors may be used in low-energy circuit where they are properly supported and not subject to undue vibration or movements.

9 Alarms

The alarm system is to be able to indicate more than one fault at the same time and be so arranged that acceptance of one fault is not to inhibit another alarm. Audible alarms are to be maintained until they are acknowledged, and visual indication is to remain until the fault is corrected.

11 Safety System

Safety systems are to be of the fail-safe type and are to respond automatically to fault conditions that may endanger the machinery or safety of the crew. This automatic action is to cause the machinery to take the least drastic action first, as appropriate, by reducing its normal operating output or switching to a stand-by machinery and last, by stopping it, i.e., disrupting source of fuel or power supply, etc. However, the propulsion machinery is to automatically shut down upon a loss of lubricating oil or an overspeed condition, and such conditions are to be alarmed. Where arrangements for overriding the shutdown of the main propelling machinery are fitted, these are to be as to preclude inadvertent activation. Visual means shall be provided to show whether or not it has been activated.

13 Bridge Control of Propulsion Machinery

13.1 General

The requirements in 4-9-2/13.1 through 4-9-2/13.9 are applicable.

13.3 Local Control

It is to be possible to control the propelling machinery locally in the case of failure in any part of the automatic or remote control systems.

13.5 Bridge Control Indicators

Indicators for the following items are to be fitted on the navigation bridge:

- i) Propeller speed and direction where fixed pitch propellers are fitted;
- ii) Propeller speed and pitch position where controllable pitch propellers are fitted;
- iii) For air-started engines, an alarm is to be provided to indicate low starting air pressure and is to be set at a level which still permits main engine starting operation;
- iv) An alarm is to be provided for low control fluid pressure for controllable pitch propellers.

15 Requirements for Periodically Unattended Propulsion Machinery Spaces

15.1 Fire Protection

15.1.1 Fire Prevention

15.1.1(a) Piping for high pressure fuel injection and return piping on main and auxiliary engines is to be effectively shielded and secured to prevent fuel or fuel mist from reaching a source of ignition on the engine or its surroundings. Leakages from such piping are to be collected in a suitable drain tank provided with high level alarm audible at the navigation bridge.

15.1.1(b) Drip trays for collecting fuel and lubricating oil are to be fitted below pumps, heaters, burners, tanks not forming part of the vessel's structure, etc., with connections to a suitable drain tank with high level alarm audible at the navigation bridge.

15.1.1(c) Where daily service fuel oil tanks are filled automatically or by remote control, means are to be provided to prevent overflow spillages. Similar consideration is to be given to other equipment which treat flammable liquids automatically (e.g., fuel oil purifiers), which whenever practicable shall be installed in special space reserved for purifiers and their heaters.

15.1.1(d) Where fuel oil daily service tanks or settling tanks are fitted with heating arrangements, a high temperature alarm, audible at the navigation bridge, is to be provided if the flashpoint of the fuel oil can be exceeded.

15.1.2 Fire Detection

A fire detection system is to be provided for the machinery spaces.

15.3 Protection Against Flooding

Bilges in machinery spaces are to be provided with a high level alarm in such a way that the accumulation of liquids is detected at normal angles of trim and heel. The detection system is to initiate an audible and visual alarm on the navigation bridge.

15.5 Alarms and Displays

The following alarms and displays are to be provided at the navigation bridge.

	<i>Items</i>	<i>Display</i>	<i>Alarm</i>
1	L.O. Pressure to main engine and reduction gear	Pressure	Low
2	Engine coolant	Temperature	High
3	Starting air (if applicable) pressure		Low
4	Propeller Speed	RPM	
5	Propeller Direction	Ahead	
6	or	Astern	
7	Pitch	Pitch	
8	Steering gear motor		Stopped
9	Control power	Available	Failure
10	Generator voltage	Volt ⁽¹⁾	
11	Generator current	Amps ⁽¹⁾	
12	Fuel oil day tanks	Level ⁽¹⁾	Low
13	Fuel oil tanks heater temperature [see 4-9-11/15.1.1(d)]		High
14	Oil collection tank [see 4-9-11/15.1.1(a) & 4-9-11/15.1.1(b)]	Level ⁽¹⁾	High
15	Bilge level	Light ⁽¹⁾	High
16	Fire alarm	Light ⁽¹⁾	Fire

Note:

- 1 As an alternative, these displays may be provided locally.