



GUIDE FOR BUILDING AND CLASSING

**HIGH SPEED CRAFT
FEBRUARY 2012**

**PART 3
HULL CONSTRUCTION AND EQUIPMENT**

**American Bureau of Shipping
Incorporated by Act of Legislature of
the State of New York 1862**

**Copyright © 2012
American Bureau of Shipping
ABS Plaza
16855 Northchase Drive
Houston, TX 77060 USA**

Hull Construction and Equipment**CONTENTS**

CHAPTER 1	General	1
	Section 1	Definitions
		4
	Section 2	General Requirements
		12
	Section 3	Direct Analysis Methods
		19
	Section 4	Guide for Finite Element Analysis
		31
CHAPTER 2	Hull Structures and Arrangements	34
	Section 1	Primary Hull Strength
		45
	Section 2	Design Pressures
		57
	Section 3	Plating
		70
	Section 4	Internals
		88
	Section 5	Hull Structural Arrangement
		100
	Section 6	Arrangement, Structural Details and Connections
		106
	Section 7	Keels, Stems, Shaft Struts, and Propeller Nozzles
		122
	Section 8	Rudders
		128
	Section 9	Protection of Deck Openings
		146
	Section 10	Protection of Shell Openings
		154
	Section 11	Bulwarks, Rails, Ports, Portlights, Windows, Ventilators, Tank Vents and Overflows
		167
	Section 12	Protective Coatings
		178
	Section 13	Welding, Forming and Weld Design
		182
	Appendix 1	Guidelines for Calculating Bending Moment and Shear Force in Rudders and Rudder Stocks
		186
	Appendix 2	Guide on Analysis of the Cross Deck Structure of a Multi-hull Craft
		191
	Appendix 3	Alternative Method for Determination of "V" Shaft Strut Requirements
		195
CHAPTER 3	Subdivision and Stability	197
	Section 1	General Requirements
		198
	Appendix 1	Onboard Computers for Stability Calculations
		200
CHAPTER 4	Fire Safety Measures	207
	Section 1	Structural Fire Protection
		208

CHAPTER 5	Equipment.....	210
Section 1	Anchoring and Mooring Equipment	212
Appendix 1	Alternative Standard for the Required Anchor Size.....	230
CHAPTER 6	Navigation.....	231
Section 1	Visibility.....	232
CHAPTER 7	Testing, Trials and Surveys During Construction – Hull.....	236
Section 1	Tank, Bulkhead and Rudder Tightness Testing	237
Section 2	Trials	242
Section 3	Surveys	243

This Page Intentionally Left Blank

PART
3

CHAPTER **1** **General**

CONTENTS

SECTION 1	Definitions.....	4
1	Application	4
3	Length	4
3.1	Scantling Length (L)	4
3.3	Freeboard Length (L_f).....	4
5	Breadth.....	4
7	Depth.....	5
9	Draft for Scantlings	5
11	Decks	5
11.1	Freeboard Deck.....	5
11.3	Bulkhead Deck	5
11.5	Strength Deck.....	5
11.7	Superstructure Deck.....	5
13	Superstructure	5
15	Deckhouses	5
17	Displacement and Block Coefficient	6
17.1	Displacement.....	6
17.3	Block Coefficient (C_b).....	6
19	Gross Tonnage	6
21	Deadweight (DWT)	6
23	Significant Wave Height.....	6
25	Speed.....	6
27	Rabbit Line (Fiber Reinforced Plastic).....	6
29	Administration	6
31	Passenger Craft	7
33	Cargo Craft	7
35	Passenger	7
37	Place of Refuge	7
39	Crewboat.....	7
39.1	Industrial Personnel.....	7
41	Fiber-Reinforced Plastic (FRP)	7
41.1	Reinforcement	7
43.3	Resin	9
43.5	Laminate.....	10
43.7	Encapsulation.....	11
45	Units	11
	FIGURE 1.....	4

SECTION 2	General Requirements	12
1	Materials.....	12
1.1	Selection of Material Grade	12
1.3	Note for the Users.....	13
3	Workmanship	13
5	Design	14
5.1	Continuity.....	14
5.3	Openings	14
5.5	Brackets.....	15
5.7	Structural Design Details	17
5.9	Termination of Structural Members.....	17
7	Effective Width of Plating	17
7.1	FRP Laminates.....	17
7.3	Steel and Aluminum Plating.....	18
TABLE 1	Material Grades.....	12
TABLE 2	Material Class of Structural Members.....	13
TABLE 3A	Brackets (Steel).....	16
TABLE 3B	Brackets (Aluminum).....	16
FIGURE 1	14
FIGURE 2	14
FIGURE 3	14
FIGURE 4	Bracket	15
FIGURE 5	Effective Width of FRP Plating	18
SECTION 3	Direct Analysis Methods.....	19
1	General	19
3	Loading Conditions	19
3.1	General.....	19
3.3	Environmental and Service Conditions.....	19
3.5	Loading Conditions for Direct Analysis	20
5	Motion Predictions	21
5.1	Model Testing.....	21
5.3	Accelerations from Direct Analysis	22
7	Load Predictions	22
7.1	Global Loads	22
7.3	Local Loads	23
9	Structural Response	25
9.1	Global Response	25
9.3	Local Response	26
11	Structural Acceptability	28
11.1	Beam, Grillage, or Plane Frame Analysis	28
11.3	Finite Element Analysis	28
TABLE 1	Sea States.....	19

SECTION 4	Guide for Finite Element Analysis	31
1	General	31
3	Structural Modeling	31
3.1	Finite Element Types.....	31
3.3	Model Types.....	31
3.5	Modeling Guidance	32
3.7	Boundary Conditions	32
3.9	Loads.....	32
3.11	Stress Criteria.....	32
TABLE 1	Finite Element Type	31
TABLE 2	Stress Limits for Plate Element Models	33

PART
3

CHAPTER **1** **General**

SECTION **1** **Definitions**

1 **Application**

The following definitions of terms apply throughout the requirements in this Guide.

3 **Length**

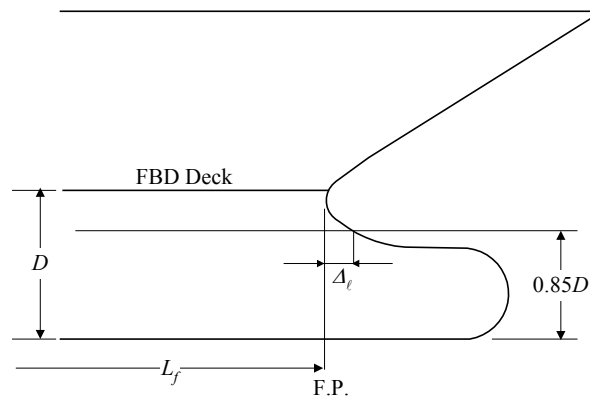
3.1 **Scantling Length (L)**

L is the distance in meters (feet) on the summer load line from the fore side of the stem to the centerline of the rudder stock. For use with the Rules, L is not to be less than 96% and need not be greater than 97% of the length on the summer load line. The forward end of L is to coincide with the fore side of the stem on the waterline on which L is measured.

3.3 **Freeboard Length (L_f)**

L_f is the distance in meters (feet) on a waterline at 85% of the least molded depth measured from the top of the keel from the fore side of the stem to the centerline of the rudder stock or 96% of the length on that waterline, whichever is greater. Where the stem is a fair concave curve above the waterline at 85% of the least molded depth and where the aftmost point of the stem is above the waterline, the forward end of the length, L_f , is to be taken at the aftmost point of the stem above that waterline. See 3-1-1/Figure 1.

FIGURE 1



5 **Breadth**

B is the greatest molded breadth, in meters (feet).

Breadth used in 3-2-1/1.1.1 for craft which have flare or tumblehome, is the mean breadth of the waterline breadth and the maximum breadth between the waterline and main deck at the longitudinal center of flotation (LCF).

7 Depth

D is the molded depth, in meters (feet), measured at the middle of the length L , from the molded keel line to the top of the freeboard deck beams at the side of the craft. On craft with rabbeted keel construction, D is to be measured from the rabbet line. In cases where watertight bulkheads extend to a deck above the freeboard deck and are to be recorded in the *Record* as effective to that deck, D is to be measured to the bulkhead deck.

9 Draft for Scantlings

d is the draft, in meters (feet), measured at the middle of the length L from the molded keel or the rabbet line at its lowest point to the estimated summer load waterline or the design load waterline in the displacement mode.

11 Decks

11.1 Freeboard Deck

The freeboard deck is normally the uppermost continuous deck having permanent means for weathertight closing of all openings in its weather portions, and below which all openings in the craft side are equipped with permanent means for watertight closure.

In cases where a craft is designed for a special draft considerably less than that corresponding to the least freeboard obtainable under the International Load Line Regulations, the freeboard deck for the purpose of the Rules may be taken as the lowest actual deck from which the draft can be obtained under those regulations.

11.3 Bulkhead Deck

The bulkhead deck is the highest deck to which watertight bulkheads extend and are made effective.

11.5 Strength Deck

The strength deck is the deck which forms the top of the effective hull girder at any part of its length. See Section 3-2-1.

11.7 Superstructure Deck

A superstructure deck is a deck above the freeboard deck to which the side shell plating extends or of which the sides are fitted inboard of the hull side not more than 4% of the breadth, B . Except where otherwise specified, the term superstructure deck where used in this Guide refers to the first such deck above the freeboard deck.

13 Superstructure

A superstructure is an enclosed structure above the freeboard deck having side plating as an extension of the shell plating, or not fitted inboard of the hull side more than 4% of the breadth B .

15 Deckhouses

A deckhouse is an enclosed structure above the freeboard deck, having side plating set inboard of the hull side-shell plating more than 4% of the breadth B of the craft.

17 Displacement and Block Coefficient

17.1 Displacement

The displacement Δ , is the mass displacement of the craft in the design condition in metric tons (long tons), unless otherwise specifically noted.

17.3 Block Coefficient (C_b)

C_b is the block coefficient obtained from the following equation:

$$C_b = \Delta / 1.025LB_{wl}d \quad (\text{SI \& MKS units})$$

$$C_b = 35\Delta / LB_{wl}d \quad (\text{US units})$$

where

$$\Delta = \text{molded displacement, as defined in 3-1-1/17.1}$$

$$L = \text{scantling length, as defined in 3-1-1/3}$$

$$d = \text{draft, as defined in 3-1-1/9}$$

$$B_{wl} = \text{greatest molded breadth at the design load line}$$

19 Gross Tonnage

The measurement of the internal volume of spaces within the craft as defined by the International Convention on Tonnage Measurement of Ships, 1969.

21 Deadweight (DWT)

For the purpose of this Guide, deadweight (DWT), is the difference, in metric tons (long tons), between the displacement of the craft at its summer load line or the craft with all tanks filled, maximum cargo loaded, maximum stores, and personnel or passengers and their effects on board, in water having a specific gravity of 1.025, and the unloaded weight of the craft. For the purpose of this Guide, the unloaded weight is the displacement of the craft, in metric tons (long tons), with no cargo, fuel, lubricating oil, ballast water, fresh water nor feed water in tanks, no consumable stores, and no personnel or passengers nor their effects.

23 Significant Wave Height

Significant wave height is the average height of the one-third highest observed wave heights over a given period.

25 Speed

Speed is the design speed in knots with the craft running ahead at the maximum continuous rated shaft rpm and at the summer load waterline. Operational speed is 90% of design speed.

27 Rabbet Line (Fiber Reinforced Plastic)

The rabbet line is the line intersection between the outside of a craft's bottom and a craft's keel. Where there is no keel, the rabbet line is the bottom of the craft.

29 Administration

The government of the state whose flag the craft is intended to fly.

31 Passenger Craft

Any craft which carries more than twelve passengers. See also 5-1-1/13.

33 Cargo Craft

Any craft other than a passenger craft, which is capable of maintaining the main functions of safety systems of unaffected spaces after damage in any one compartment on board. See also 1-2-2/1.

35 Passenger

A passenger is every person other than the master and members of the crew or other persons employed or engaged in any capacity on board a craft on the business of that craft, and a child under one year of age.

37 Place of Refuge

Any naturally or artificially sheltered area which may be used as shelter by a craft under conditions likely to endanger its safety.

39 Crewboat

A craft specifically fitted for the transferring/transporting of industrial personnel in the offshore oil and gas industry between a shore base facility and the offshore oil and offshore gas installations and vice versa. Crewboats may also carry cargo, however, are not considered as a Passenger Craft. See also Section 5-2-1

39.1 Industrial Personnel

Every person carried onboard a Crewboat for the sole purpose of carrying out the business or functions of the offshore installations. See also Section 5-2-1

41 Fiber-Reinforced Plastic (FRP)

FRP consists of two basic components: a glass-filament or other material fiber reinforcement and a plastic, or resin, in which the reinforcing material is imbedded.

41.1 Reinforcement

Reinforcement is a strong, inert material bonded into the plastic to improve its strength, stiffness and impact resistance. Reinforcements are usually fibers of glass (a lime-alumina-silicate composition having a low alkali content) or other approved material such as aramid or carbon fiber, in a woven or non-woven form, with a strong adhesive bond to the resin.

41.1.1 Strand

A bundle of continuous filaments combined in a single, compact unit.

41.1.2 Roving

A band or ribbon of parallel strands grouped together.

41.1.3 Yarn

A twisted strand or strands suitable for weaving into a fabric.

41.1.4 Binder

The agent applied in small quantities to bond the fibers in mat form.

41.1.5 Coupling Agent

An active water soluble chemical that allows resin to adhere to glass.

- 41.1.6 Chopped-strand Mat
A blanket of randomly oriented chopped-glass strands held together with binder.
- 41.1.7 Woven Roving
A coarse fabric woven from rovings.
- 41.1.8 Cloth
A fabric woven from yarn
- 41.1.9 Peel-Ply
An “E” glass fabric that does not have any coupling agent applied, used as a protective covering on a laminate being prepared for a secondary bond to keep foreign particles from adhering to the surface.
- 41.1.10 Uni-directional
A woven or non-woven reinforcement with substantially more fibers in one principal axis of the reinforcing ply.
- 41.1.11 Double Biased
A woven or non-woven reinforcement with fibers primarily at +45° to the principal axes of the reinforcing ply.
- 41.1.12 Knitted or Stitched Fabrics
Two or more layers of unidirectional fabrics that are stitched together.
- 41.1.13 Bi-axial Fabric
A stitched or knitted reinforcement with fibers primarily in the two principal axes of the reinforcing ply.
- 41.1.14 Tri-axial Fabric
A stitched or knitted reinforcement with fibers running in one principal axis of the ply and in addition, with fibers running at + and -45° to the warp.
- 41.1.15 Ply Principal Axes
The two principal axes of a reinforcing ply are the axis that is parallel to the warp and the axis that is parallel to the fill.
- 41.1.16 Warp
The roving or yarn running lengthwise in woven fabric (in the “roll direction”).
- 41.1.17 Fill, Weft or Woof
The roving or yarn running at right angles to the warp in a woven fabric.
- 41.1.18 “E” glass
A family of glass reinforcement material of aluminoborosilicate composition and having high electrical resistivity.
- 41.1.19 “S” glass
A family of glass reinforcement material of magnesium aluminosilicate composition that contains a higher silicon content and provides higher strength and stiffness properties than “E” glass.
- 41.1.20 Kevlar
An aramid fiber reinforcement.
- 41.1.21 Carbon Fiber
A reinforcement material made of mostly carbon produced by the pyrolysis of organic precursor fibers in an inert environment.

43.3 Resin

Resin is a highly reactive synthetic that in its initial stage is a liquid, but upon activation is transformed into a solid.

43.3.1 Accelerator

A material that, when mixed with a catalyst or resin, speeds the cure time.

43.3.2 Additive

A substance added to another substance, usually to improve properties, such as plasticizers, initiators, light stabilizers and flame retardants.

43.3.3 Catalyst or Initiator

A material that is used to activate resin, causing it to harden.

43.3.4 Crazeing

Hairline cracks, either within or on the surface of resin, caused by mechanical or thermal stresses.

43.3.5 Cure

To change resin from a liquid to a solid.

43.3.6 Cure time

The time required for resin to change from a liquid to a solid after a catalyst has been added.

43.3.7 Exothermic Heat

The heat given off as the result of the action of a catalyst on resin.

43.3.8 Filler

A material added to resin to modify its working properties or other qualities, or to lower densities.

43.3.9 Gel

A partially cured resin in a semi-solid state similar to gelatin in consistency.

43.3.10 Gel Time

The time required to change a flowable, liquid resin into a nonflowing gel.

43.3.11 Inhibitor

A material that retards activation or initiation of resin, thus extending shelf life or influencing exothermic heat or gel time.

43.3.12 Polymerization

The reaction that takes place when resin is activated or initiated.

43.3.13 Pot Life

The length of time that a catalyzed resin remains workable.

43.3.14 Shelf Life

The length of time that an uncatalyzed resin maintains its working properties while stored in a tightly sealed, opaque container.

43.3.15 Tack

The degree of stickiness of the resin.

43.3.16 Thixotropy

The property or phenomenon, exhibited by some resins, of becoming jelly-like at rest but becoming fluid again when stirred or agitated. This facilitates the application of the resin to inclined or vertical surfaces

43.3.17 Polyester Resin

A thermosetting resin that is formed by combining saturated and unsaturated organic acids. Such as orthophthalic and isophthalic acids.

43.3.18 Vinylester Resin

A thermosetting resin that consists of a polymer chain and an acrylate or methacrylate termination.

43.3.19 Epoxy

A resin that contains one or more of the epoxide groups.

43.5 Laminate

A laminate is a material composed of successive bonded layers, or plies, of resin and fiber or other reinforcing substances.

43.5.1 Bi-directional Laminate

A laminate having essentially the same strength and elastic properties in the two plane principal axes. Bi-directional laminates may be constructed of bi-axial, double bias, tri-axial, mat or unidirectional reinforcing layers, or a combination of any of these.

43.5.2 Uni-directional Laminate

A laminate with substantially more of the fibers in the plane of the laminate oriented in one of the two principal axis of the laminate plane so that the mechanical properties along that axis are appreciably higher than along the other natural axis.

43.5.3 Sandwich Laminate

A laminate consisting of two fiber reinforced plastic skins attached to a non-structural or structural core (see 3-1-1/47.7 "Encapsulation").

43.5.4 Barcol Hardness

A measurement of the hardness of a laminate and thereby the degree of completion of the cure.

43.5.5 Delamination

The separation of the layers of material in a laminate.

43.5.6 Gel Coat

The first resin applied to mold when fabricating a laminate to provide a smooth protective surface for the laminate.

43.5.7 Layup

The process of applying to a mold the layers of resin and reinforcing materials that make up a laminate. These materials are then compressed or densified with a roller or squeegee to eliminate entrapped air and to spread resin evenly. Also a description of the component materials and geometry of a laminate.

43.5.8 Verified Minimum Mechanical Property

The mechanical properties, in Part 2, Chapter 6, of laminates differing from the basic, verified by the appropriate test(s) listed in 2-6-1/Table 1.

43.5.9 Laminate Principal Axes

The two principal axes of a square or rectangular plate panel are for the application of this Guide those perpendicular and parallel to the plate panel edges.

43.5.10 Vacuum Bagging

A method used to apply a uniform pressure over an area by applying a vacuum to that area.

43.5.11 Resin Impregnation

A process of construction for large layers of fabric that consists of running a roll of fabric through a resin bath to completely saturate the fabric.

43.5.12 Resin Transfer Molding

A closed mold method that mechanically pumps resin through dry fabric previously placed in the mold.

43.5.13 Resin Infusion

A method of FRP construction that uses a vacuum to pull catalyzed resin through dry fabric.

43.5.14 Primary Bond

The bond that is formed between two laminated surfaces when the resin on both surfaces has not yet cured.

43.5.15 Secondary Bond

The bond that is formed between two laminated surfaces when the resin on one of the two surfaces has cured.

43.5.16 Post Cure

The act of placing a laminate in an autoclave and raising the temperature to assist in the cure cycle of the resin.

43.5.17 Autoclave

A large oven used in post curing large laminated parts.

43.7 Encapsulation

The containment of a core material, such as softwoods, plywood, balsa, PVC (cross linked) or linear polymer, within FRP laminates. The cores may be structurally effective or ineffective.

43.7.1 Bedding Putty

Material used to adhere the core material to the FRP skins.

43.7.2 Scores

Slits cut into the core material to aid in forming the core to complex shapes.

45 Units

This Guide is written in three systems of units: SI units, MKS units and US customary units. Each system is to be used independently of any other system.

Unless indicated otherwise, the format of presentation in this Guide of the three systems of units is as follows:

SI units (MKS units, US customary units)

PART
3

CHAPTER **1 General**

SECTION **2 General Requirements**

1 Materials

This Guide is intended for welded craft constructed of steel, welded craft constructed of aluminum, and fiber reinforced plastic (FRP) craft; complying with the requirements of Part 2, Chapters 1 and 2, 5, and 6, respectively. The use of materials other than those specified in Part 2, Chapters 1, 2, 5, and 6 and the corresponding scantlings will be specially considered.

1.1 Selection of Material Grade

For craft 61 m (200 ft) and over in length, steel materials are not to be lower grades than those required by 3-1-2/Table 1 for the material class given in 3-1-2/Table 2 for the particular location.

**TABLE 1
Material Grades**

Thickness (<i>t</i>) mm (in.)	Material Class	
	<i>I</i>	<i>II</i>
$t \leq 15$ ($t \leq 0.60$)	A ⁽¹⁾ , AH	A, AH
$15 < t \leq 20$ ($0.60 < t \leq 0.79$)	A, AH	A, AH
$20 < t \leq 25$ ($0.79 < t \leq 0.98$)	A, AH	B, AH
$25 < t \leq 30$ ($0.98 < t \leq 1.18$)	A, AH	D, AH
$30 < t \leq 35$ ($1.18 < t \leq 1.38$)	B, AH	D, AH
$35 < t \leq 40$ ($1.38 < t \leq 1.57$)	B, AH	D, AH
$40 < t \leq 51$ ($1.57 < t \leq 2.00$)	D, AH	E, DH

Notes:

- 1 ASTM A36 steel otherwise tested and certified to the satisfaction of ABS may be used in lieu of Grade A for a thickness up to and including 12.5 mm (0.5 in.) for plate and 15 mm (0.6 in.) for sections.

TABLE 2
Material Class of Structural Members

<i>Structural members</i>	<i>Material Class</i>	
	<i>Within 0.4L Amidships</i>	<i>Outside 0.4L Amidships</i>
Shell		
Bottom plating including keel plate	II	A ⁽³⁾ /AH
Bilge strake	II	A ⁽³⁾ /AH
Side Plating	I	A ⁽³⁾ /AH
Sheer Strake at strength deck ⁽¹⁾	II	A ⁽³⁾ /AH
Decks		
Strength deck plating ⁽²⁾	II	A ⁽³⁾ /AH
Stringer plate in strength deck ⁽¹⁾	II	A ⁽³⁾ /AH
Strength deck strake on tankers at longitudinal bulkhead	II	A ⁽³⁾ /AH
Strength deck plating within line of hatches and exposed to weather, in general	I	A ⁽³⁾ /AH
Longitudinal Bulkheads		
Lowest strake in single bottom craft	I	A ⁽³⁾ /AH
Uppermost strake including that of the top wing tank	II	A ⁽³⁾ /AH
Other Structures in General		
External continuous longitudinal members and bilge keels	II	A ⁽³⁾ /AH
Stem frames, rudder horns, rudders, shaft brackets	-	I
Strength members not referred to in above categories and above local structures	A ⁽³⁾ /AH	A ⁽³⁾ /AH

Notes:

- 1 A radius gunwale plate may be considered to meet the requirements for both the stringer plate and the sheer strake, provided it extends suitable distances inboard and vertically. For formed material see 2-4-1/3.13.
- 2 Plating at the corners of large hatch openings are to be specially considered.
- 3 ASTM A36 steel otherwise tested and certified to the satisfaction of ABS may be used in lieu of Grade A for thickness up to and including 12.5 mm (0.5 in.) for a plate and 40 mm (1.57 in.) for sections.

1.3 Note for the Users

The attention of users is drawn to the fact that when fatigue loading is present, the effective strength of higher-strength steel in a welded construction may not be greater than that of ordinary-strength steel. Precautions against corrosion fatigue to higher strength steel and aluminum alloy materials may also be necessary.

3 Workmanship

All workmanship is to be of commercial marine quality and acceptable to the Surveyor. Welding is to be in accordance with the requirements of Part 2, Chapter 4, Appendix 2-5-A1, Part 2, Chapter 14, and Section 3-2-13.

5 Design

5.1 Continuity

Care is to be taken to provide structural continuity. Changes in scantlings are to be gradual, such that the maximum angle from horizontal is 45° , see 3-1-2/Figure 1. Strength members are not to change direction abruptly, such that the maximum change in direction is 45° , see 3-1-2/Figure 2. Where primary structural members terminate at another structural member, tapering of the primary member or tapering brackets may be required beyond the other structural member, as indicated in 3-1-2/Figure 3, and as required in 3-2-5/1. Stanchions and bulkheads are to be aligned to provide support and to minimize eccentric loading. Major appendages outside the hull and strength bulkheads in superstructures are to be aligned with major structural members within the hull.

FIGURE 1

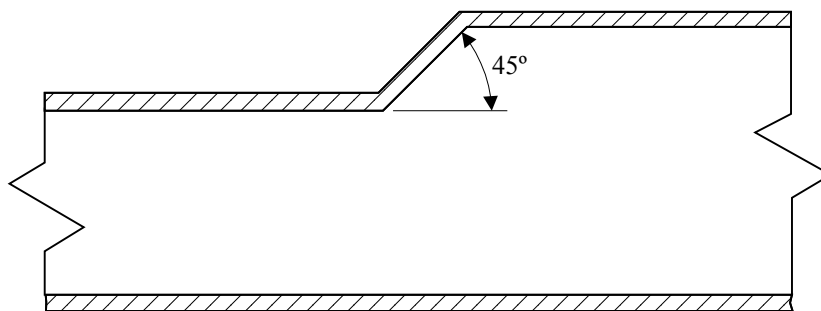


FIGURE 2

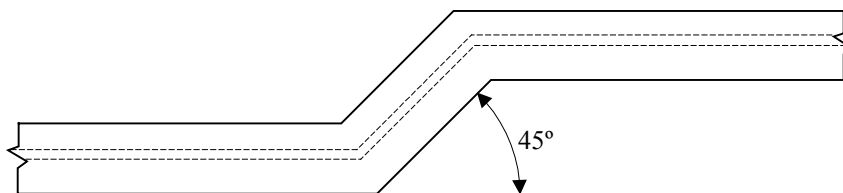
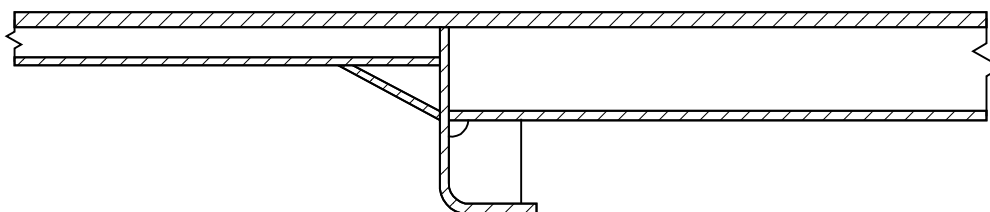


FIGURE 3



5.3 Openings

The structural arrangements and details are to be in accordance with Section 3-2-6. In general, major openings such as doors, hatches, and large vent ducts are to be avoided in the hull in close proximity to the gunwale. Corners of openings in strength structures are to have generous radii. Compensation may be required for openings.

5.5 Brackets

5.5.1 Steel Brackets

Where brackets are fitted having thicknesses as required by 3-1-2/Table 3A and faces at approximately 45 degrees with the bulkhead deck or shell, and the bracket is supported by a bulkhead, deck or shell structural member, the length of each member, ℓ , may be measured at a point 25% of the extent of the bracket beyond the toe of the bracket as shown in 3-1-2/Figure 4. The minimum overlap of the bracket arm along the stiffener is not to be less than obtained from the following equation:

$$x = 1.4y + 30 \text{ mm} \qquad x = 1.4y + 1.2 \text{ in.}$$

where

x = length of overlap along stiffener, in mm (in.)

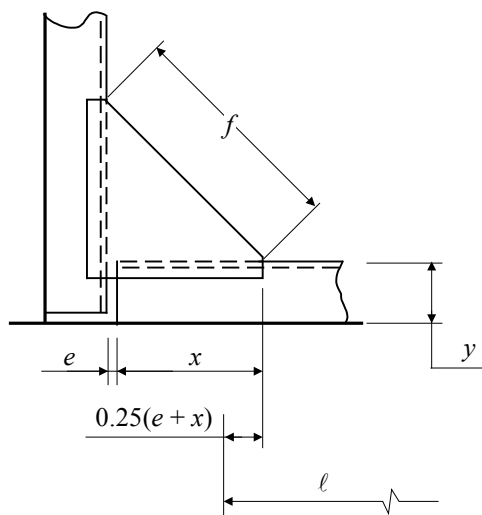
y = depth of stiffener, in mm (in.)

Where a bracket laps a member, the amount of overlap generally is to be 25.5 mm (1 in.).

5.5.2 Aluminum Brackets

Aluminum brackets are to comply with 3-1-2/5.5.1 except that the thicknesses are given in 3-1-2/Table 3B.

**FIGURE 4
Bracket**



**TABLE 3A
 Brackets (Steel)**

<i>Thickness</i>			
<i>Length of Face, f, mm</i>	<i>Millimeters</i>		<i>Width of Flange, mm</i>
	<i>Plain</i>	<i>Flanged</i>	
Not exceeding 305	5.0	—	—
Over 305 to 455	6.5	5.0	40
Over 455 to 660	8.0	6.5	50
Over 660 to 915	11.0	8.0	65
Over 915 to 1370	14.0	9.5	75

<i>Thickness</i>			
<i>Length of Face f, in.</i>	<i>Inches</i>		<i>Width of Flange, in.</i>
	<i>Plain</i>	<i>Flanged</i>	
Not exceeding 12	$\frac{3}{16}$	—	—
Over 12 to 18	$\frac{1}{4}$	$\frac{3}{16}$	1½
Over 18 to 26	$\frac{5}{16}$	$\frac{1}{4}$	2
Over 26 to 36	$\frac{7}{16}$	$\frac{5}{16}$	2½
Over 36 to 54	$\frac{9}{16}$	$\frac{3}{8}$	3

**TABLE 3B
 Brackets (Aluminum)**

<i>Thickness</i>			
<i>Length of Face, f, mm</i>	<i>Millimeters</i>		<i>Width of Flange, mm</i>
	<i>Plain</i>	<i>Flanged</i>	
Not exceeding 305	7.0	—	—
Over 305 to 455	9.5	7.0	40
Over 455 to 660	11.5	9.5	50
Over 660 to 915	16.0	11.5	65
Over 915 to 1370	20.0	13.5	75

<i>Thickness</i>			
<i>Length of Face f, in.</i>	<i>Inches</i>		<i>Width of Flange, in.</i>
	<i>Plain</i>	<i>Flanged</i>	
Not exceeding 12	$\frac{1}{4}$	—	—
Over 12 to 18	$\frac{3}{8}$	$\frac{1}{4}$	1½
Over 18 to 26	$\frac{7}{16}$	$\frac{3}{8}$	2
Over 26 to 36	$\frac{5}{8}$	$\frac{7}{16}$	2½
Over 36 to 54	$\frac{13}{16}$	$\frac{9}{16}$	3

5.7 Structural Design Details

The designer is to give consideration to the following:

5.7.1

The thickness of internals in locations susceptible to rapid corrosion.

5.7.2

The proportions of built-up members to comply with established standards for buckling strength.

5.7.3

The design of structural details such as noted below, against the harmful effects of stress concentrations and notches:

- i)* Details of the ends, the intersections of members and associated brackets.
- ii)* Shape and location of air, drainage or lightening holes.
- iii)* Shape and reinforcement of slots or cutouts for internals.
- iv)* Elimination or closing of weld scallops in way of butts, “softening” of bracket toes, reducing abrupt changes of section or structural discontinuities.

5.7.4

Proportions and thickness of structural members to reduce fatigue response due to engine, propeller or wave-induced cyclic stresses, particularly for higher-strength steels.

Standard construction details based on the above considerations are to be indicated on the plans or in a booklet submitted for review and comment.

5.9 Termination of Structural Members

Unless permitted elsewhere in this Guide, structural members are to be effectively connected to the adjacent structures in such a manner to avoid hard spots, notches and other harmful stress concentrations. Where members are lightly loaded and not required to be attached at their ends, special attention is to be given to the end taper, by using brackets or by a sniped end of not more than 30°. Bracket toes or sniped ends are to be kept within 25 mm (1.0 in.) of the adjacent member and the depth at the toe or snipe end is generally not to exceed 15 mm (0.60 in.). Where a strength deck or shell longitudinal terminates without end attachment, it is to extend into the adjacent transversely framed structure or stop at a local transverse member fitted at about one transverse frame space beyond the last floor or web that supports the longitudinal.

7 Effective Width of Plating

The section modulus and moment of inertia of stiffening members are provided by the member and a portion of the plating to which it is attached. The effective width is as given in the following paragraphs. The section modulus and moment of inertia of a shape, bar, fabricated section, or laid-up member not attached to plating is that of the member only.

7.1 FRP Laminates

Where the plating is an FRP single-skin laminate, the maximum effective width of plating for floors, frames, beams and bulkhead stiffeners is not to exceed either the stiffening member spacing or the width obtained from the following equation, whichever is less. See 3-1-2/Figure 5.

$$w = 18t + b$$

where:

- w = effective width of plating, in mm (in.)
- t = thickness of single skin plating, in mm (in.)
- b = net width of stiffening member, in mm (in.), but not more than $18t$

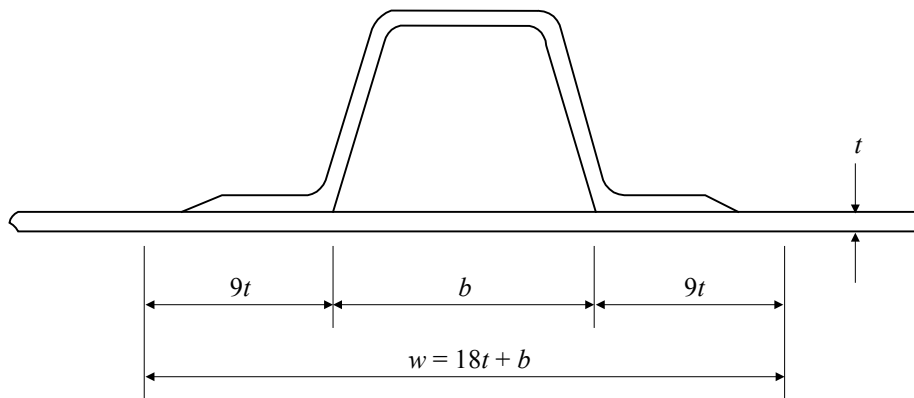
Where the plating is an FRP sandwich laminate with a flexurally and compressively ineffective (balsa, cross linked PVC, or linear polymer) core, t in the above equation is the thickness of a single skin laminate having the same moment of inertia per unit width as the two skins of the sandwich about the neutral axis of the sandwich, excluding the core.

For a stiffening member along an opening, the maximum effective width of plating is equal to either one-half the stiffening member spacing or the width obtained from the following equation, whichever is less.

$$w = 9t + b$$

where w , t and b are as defined above.

FIGURE 5
Effective Width of FRP Plating



7.3 Steel and Aluminum Plating

7.3.1 Primary Structural Members

The effective width of plating for deep supporting members is to equal to the lesser of either one half the sum of spacing on each side of the member, 0.33 times the unsupported span, ℓ , or 750 mm (30 in.). For girders and webs along hatch openings, the effective width of plating is to be half of that obtained from the above. Due account is to be taken in regards to plate buckling, see 3-2-3/1.1.

7.3.2 All Other Structural Members

The maximum effective width of plating is equal to either one-half the sum of spacing on each side of the member or the width obtained from the following equation, whichever is less.

Steel Members $w = 80t$

Aluminum Members $w = 60t$

where

w = effective width of plating, in mm (in.)

t = thickness of single skin plating, in mm (in.)

For a stiffening member along an opening, the maximum effective width of plating is one-half of the effective width given above.

PART

3

CHAPTER **1** **General**

SECTION **3** **Direct Analysis Methods**

1 **General**

This Section states requirements for a variety of direct analysis methods that can be used in lieu of or in conjunction with the specific requirements given in Sections 3-2-1, 3-2-2, 3-2-3, and 3-2-4 or to meet the requirements in 1-1-4/5. If the structure of the craft complies with 3-1-3/3.5, 3-1-3/5.3, 3-1-3/7.1.2, 3-1-3/7.3, 3-1-3/9.1, 3-1-3/9.3.3, and 3-1-3/11.3 of this section and the requirements in Sections 3-2-1, 3-2-2, 3-2-3, and 3-2-4 it will be eligible to receive the **SH-DLA** Class Notation. For guidance on the **SH-DLA** class notation not given in this Section, see the ABS *Guidance Notes on Structural Direct Analysis for High-Speed Craft*.

3 **Loading Conditions**

3.1 **General**

The loading conditions considered should include all intended operational conditions of the craft as specified by the Designer. These operating conditions are to be defined by significant wave height, wave period, and maximum operating speed. 3-1-3/Table 1 is to be used when the significant wave height is given in terms of Sea States. When the wave period is not given, the most probable modal period is to be used in the analysis.

TABLE 1
Sea States

<i>Sea State</i>	<i>Significant Wave Height m (ft)</i>
0-1	0.10 (0.3)
2	0.50 (1.6)
3	1.25 (4.1)
4	2.5 (8.2)
5	4 (13.1)
6	6 (19.7)
7	9 (29.5)
8	14 (45.9)
>8	>14 (45.9)

3.3 **Environmental and Service Conditions**

3.3.1 **General**

The environmental condition is anticipated to be described by appropriate sets of wave data. The sources and reliability of this data are to be submitted. The wave parameters used in the analysis are to be selected and documented based on the conditions given in the craft specification. If these parameters are to be used in conjunction with the requirements in 3-1-3/3.5, 3-1-3/5.3, 3-1-3/7.1.2, 3-1-3/7.3, 3-1-3/9.1, 3-1-3/9.3.3, and 3-1-3/11.3, then they should be compatible with the stochastic response and extreme value prediction methods.

3.3.2 Types of Wave Spectra

3.3.2(a) *Deep-water Ocean Waves.* Two-parameter spectra, such as the Bretschneider or P-M wave spectral formulations, are to be used. If the swell and wave components are known to interact, a bi-modal Ochi-Hubble spectrum is to be used. Directional spreading appropriate to coastal conditions is also to be applied.

3.3.2(b) *Shallow-water Waves.* Wave conditions that include the effects of bathymetry, wind field, coastal contours of the region are to be used. For fetch-limited sea conditions, JONSWAP spectrum or a modified version of the spectrum is to be used.

3.5 Loading Conditions for Direct Analysis

3.5.1 Dominant Load Parameters

A list of *Dominant Load Parameters* (DLP) is to be developed. This will include select motion and load effect parameters. Other loads, such as those due to wave impacts on the bow and stern, flare and bottom slamming, wet-deck slamming (multi-hulls) and vibration effects on local structural strength, have to be treated separately. Considerations for slamming analysis are given in 3-1-3/3.5.7.

3.5.2 Load Cases

Load cases are defined by a combination of craft loading conditions, a set of global motion and load effect parameters set forth in terms of each of the DLPs, other load components accompanying the DLPs and an equivalent wave system for the specified DLP. Justification for load cases selected for use in the structural analysis is to be submitted to ABS for review.

3.5.3 Analyses of Ship Motions, Wave Loads, and Extreme Values

Calculations are to be made using the spectral analysis-based approach, which by definition relies on the use of *Response Amplitude Operators* (RAOs). Each RAO is to be calculated for regular waves of unit amplitude for a range of wave frequencies and wave headings that will be given below.

3.5.4 Essential Features of Spectral Analysis of Motions and Loads

3.5.4(a) *General Modeling Considerations.* The model of the hull should include the masses of all equipment, vehicles and supporting structure. There is also to be sufficient compatibility between the hydrodynamic and structural models so that the application of fluid pressures onto the finite element mesh of the structural model can be done appropriately.

For the load component types and structural responses of primary interest, software formulations derived from linear idealizations are deemed to be sufficient. The capabilities and limitations of the software are to be known, and in cases where the software is not known to ABS, it may be necessary to demonstrate the adequacy of the software.

3.5.4(b) *Diffraction-Radiation Methods.* Computations of the wave-induced motions and loads are to be carried out through the application of seakeeping analysis codes utilizing three-dimensional potential flow based diffraction-radiation theory. Computation of the hydrodynamic pressures should take account of, as a minimum, all six degree-of-freedom rigid-body motions of the hull. These codes may be based either on linear (small) wave and motion amplitude assumptions or nonlinear (large) amplitude motion and wave formulations.

3.5.4(c) *Panel Model Development.* The Rankine source panel method is recommended for solving the hydrodynamic boundary value problem.

3.5.4(d) *Motion and Load-Effect Response Amplitude Operators.* For each loading condition, RAOs of all the selected DLPs are to be calculated. The RAOs are to represent the pertinent range of wave headings (β), in increments not exceeding 15 degrees. A range of wave frequencies is to be considered based on the route-specific wave conditions (see 3-1-3/3.3). The nominal range is 0.2 rad/s to 1.8 rad/s in increments of 0.05 rad/s.

The worst frequency-heading (ω , β) combination is to be determined from an examination of the RAOs for each DLP. Only the heading β_{\max} and the wave frequency ω_e at which the RAO of the DLP is a maximum, need to be used in DLA or direct analysis.

3.5.5 Extreme Values Analysis

Extreme value analysis is to be performed for each DLP to determine the maximum values. An extreme value method that follows the so-called long-term approach is to be used. The use of a validated short-term extreme value approach, which is appropriate to the craft type and route-specific environmental data, will also be considered. The supplementary use of such a short-term approach to confirm or test the sensitivity of the long-term based design values is recommended.

The relevant value to be obtained from the long-term response analysis is the most probable extreme value (MPEV) having a probability of level of 10^{-8} in terms of wave encounters.

3.5.6 Equivalent Wave

For each load case, an equivalent wave is to be determined which simulates the magnitude and location of the extreme value of the dominant load component of the load case.

The amplitude of the equivalent wave is to be determined using the extreme values of the DLP (see 3-1-3/3.5.4) and the RAO of that DLP occurring at the wave frequency and wave heading corresponding to the maximum amplitude (peak) of the RAO. The amplitude of the equivalent wave is given by:

$$a_{wj} = MPEV_j / Max RAO_j$$

where

a_{wj} = wave amplitude

$MPEV_j$ = Most Probable Extreme Value of the j^{th} DLP at a probability level equivalent to the design criterion

$Max RAO_j$ = maximum amplitude of the j^{th} DLP's RAO

3.5.7 Slamming Loads

Loads due to slamming and wave impact on craft hulls are categorized into global slamming effects and local slam-induced structural response.

3.5.7(a) Global Slamming Effects. The simplified formulae given in Section 3-2-1 may be used to account for global slamming effects in the preliminary design stage. For detailed analysis, a direct time-domain simulation involving short-term predictions are to be used for the global strength assessment of monohulls. In most cases involving high speeds, the absolute motions or relative motions will be of such large amplitude that nonlinear calculations will be required. In catamarans, wet deck slam-induced global whipping effects of the hull is to be assessed using methods that account for coupling of the symmetric and anti-symmetric modes of responses. These calculations will require time-domain analysis methods.

3.5.7(b) Local Impact Loads. Panel structures with horizontal flat or nearly flat surfaces such as a wet deck of a multi-hull craft will need to be hydroelastically modeled, where in the dynamics of the fluid and the elastic response of the plate and stiffeners are simultaneously modeled.

5 Motion Predictions

5.1 Model Testing

Craft hull motions and accelerations obtained from scale model tests may be used to validate motions predicted by computer programs. Model testing is required to be performed and reported to ABS when loads are being submitted in lieu of the loads determined in Section 3-2-2 or other loads determined by ABS. The model is to accurately represent the structure that is to be built in both principal particulars and hull geometry.

5.1.1 Testing Program

The model is to be tested over a range of speeds, headings, and wave characteristics (height, length, and period), as indicated by ABS. When this is not specified, the testing program is to include the following:

5.1.1(a) *Speeds.* The model is to be tested at the minimum speed required by ABS and the maximum achievable speed of the craft for a particular wave profile and heading.

5.1.1(b) *Headings.* The model is to be tested in head, beam, quartering, and following seas.

5.1.1(c) *Wave Parameters.* The model is to be tested in both deep water and shallow water wave conditions. These are defined in 3-1-3/3.3.2. For craft that are limited to operation in coastal regions (Coastal Craft and Riverine Craft), deep water wave profile testing is not required.

5.1.2 Model Measurements and Reporting

The parameters listed below are to be measured and reported based on the model test program. Some of the parameters listed may be derived through statistical analysis of measured data obtained from testing. When statistical analysis is used, the methods of analysis employed are to be indicated in the report.

5.1.2(a) *Vertical or Heave Acceleration.* The significant, $1/10^{\text{th}}$ highest, or $1/100^{\text{th}}$ highest vertical acceleration at the longitudinal center of gravity, bow, and stern are to be reported. The accelerometer is to be adjusted such that the acceleration due to gravity is not measured. The $1/100^{\text{th}}$ highest vertical acceleration at the longitudinal center of gravity may be used in place of n_{cg} in 3-2-2/1 and 3-2-2/3.

5.1.2(b) *Roll Acceleration.* The significant roll acceleration about a longitudinal axis through the center of gravity and the maximum roll angle are to be reported.

5.1.2(c) *Pitch Angle and Acceleration.* The significant coupled pitch-and-heave acceleration at the bow and the stern and the maximum pitch angle are to be reported.

5.3 Accelerations from Direct Analysis

5.3.1 General

The wave-induced craft motions may be determined by direct analysis. When this analysis is not performed by ABS, it is to be verified by model testing as indicated in 3-1-3/5.3.

5.3.2 Global Accelerations

Global accelerations are to be determined using the loading conditions indicated in 3-1-3/3.5 above. The $1/100^{\text{th}}$ highest vertical (heave) acceleration at the longitudinal center of gravity may be used in place of n_{cg} in Sections 3-2-1 and 3-2-2.

5.3.3 Local Accelerations

Local accelerations at points where the lightship weight of the structure, (non-liquid cargo), are located, including deck-mounted equipment, should be calculated to determine the inertia loads. For vehicle decks, wheel loading should be applied. An evenly distributed load equivalent to the weight of the vehicles may be used. The acceleration RAO at a location of interest is to be calculated to account for all translational and rotational components of motions.

The components of the gravitational acceleration in the craft's coordinate system are to be included.

7 Load Predictions

7.1 Global Loads

As a minimum, the still-water hogging and sagging moments and shear forces, the wave-induced hogging and sagging moments and shear forces and the slam-induced moments and shear force, are to be determined for monohull craft. Multi-hulled craft are to have the transverse bending moment, the torsional (or pitch connecting) moment and the transverse shear force determined in addition to the moments and shear forces determined for monohull craft. These loads are to be reported so that they can be used in conjunction with the requirements in 3-1-3/9 or Section 3-2-1.

7.1.1 Computation of Global Load Effects

7.1.1(a) Still-water Bending Moment and Shear Force. The still-water bending moments and shear forces are to be calculated in the light load, half load, and full load conditions. The light load condition consists of all components of the craft (structure, machinery, piping equipment, outfitting, wiring, interiors, paint, etc.) plus 10% of tank and cargo capacity. The half load condition is to include all components of the craft plus 50% of the tank and cargo capacity. The full load condition consists of all components of the craft plus 100% of the tank and cargo capacity. The distribution of the load is to capture all major weight discontinuities, and no single weight distribution segment is to be greater than $0.20L$.

7.1.1(b) Wave-Induced Longitudinal Bending Moment and Shear Force. The wave-induced bending moments and shear forces can be determined by using the environmental conditions outlined in 3-1-3/3.3.

7.1.1(c) Transverse Bending Moment and Shear Force – Multi-hulled Craft. The transverse bending moment and shear force may be determined by distributing the weights and loads athwartships across the craft and using the environmental conditions outlined in 3-1-3/3.3

7.1.1(d) Torsion Bending Moment. The torsional bending moment may be determined by distributing the weights and loads on segments of the hull sliced at a 45° angle from centerline and using the environmental conditions outlined in 3-1-3/3.3.

7.1.1(e) Slamming Induced Bending Moment and Shear Force. The slam induced bending moment and shear force may be calculated by applying the acceleration determined in 3-1-3/5 or in 3-2-2/1 to the lumped masses developed for 3-1-3/7.2.1(a).

7.1.2 Global Loads from Computations

Global loads from computer software programs are to be developed by loading the structure as outlined in 3-1-3/3.5. The computer program is to be capable of determining the moments and shear forces in 3-1-3/7.1 or developing loads that can be used in conjunction with finite element methods as outlined in 3-1-3/9.1.

7.3 Local Loads

Loads that differ from the pressure loads developed in Section 3-2-2 may be used to determine the required scantlings in conjunction with the requirements in 3-1-3/9.3 or Sections 3-2-3 and 3-2-4. These loads are to be developed under the loading conditions in 3-1-3/3 and the following subparagraphs.

7.3.1 External Hydrodynamic Pressure

The hydrodynamic pressures at selected points on the external contours of the hull sections, are to be calculated in regular waves.

7.3.1(a) External Pressure Components. The total hydrodynamic pressure is to include the pressure components due to waves and the components due to craft motion. Components of the hydrodynamic pressure are to be calculated from the panel model analysis of 3-1-3/3.5.3.

7.3.1(b) Pressures Accompanying the Dominant Load Parameter and Their Distribution. The external pressure is to be calculated either as a complex number or in terms of the amplitude and phase. Then, ‘simultaneously’ acting pressures over the wetted surface can be represented in the form:

$$P = (A)(a_w)\sin(\omega_e t + \epsilon_l)$$

where

P	=	simultaneous pressure
A	=	amplitude of the pressure RAO
a_w	=	equivalent wave amplitude
ω_e	=	frequency of the equivalent wave when the RAO of the dominant load component of the load case reaches its maximum
t	=	time under consideration.
ϵ_l	=	phase angle of the (other) load component’s RAO

7.3.1(c) *Pressure Loading for Finite Element Models.* The hydrodynamic pressure can be linearly interpolated to obtain the nodal pressures for the finite element models required for structural analysis.

7.3.1(d) *Pressure Loading for Guide Requirements.* For pressures that are to be used in conjunction with the requirements in Sections 3-2-3 and 3-2-4 for determining the local scantlings, the hydrodynamic pressures are to be resolved into kN/m² (tf/m², psi).

7.3.2 Internal Tank Pressure

Liquid pressures in the cargo tanks are to be calculated and applied to the structural model used in finite element analysis. Both static and dynamic pressures should be included in the analysis, assuming that there is no relative motion between the tank and the contained fluid.

7.3.2(a) *Pressure Components.* The internal tank pressure is to account for both the quasi-static and motion-induced (dynamic) pressure components. The quasi-static component results from gravity and should include craft roll and pitch rotations. The dynamic component is to be developed from the accelerations in the liquid at the tank boundary caused by the hull's motions in six degrees of freedom. These are to be obtained from motion analysis as specified in 3-1-3/3.

The total instantaneous internal tank pressure for each of the tank boundary points is to be calculated by combining the inertial and quasi-static components as follows:

$$p = p_o + \rho h_t [(g_x + a_x)^2 + (g_y + a_y)^2 + (g_z + a_z)^2]^{1/2}$$

where

- p = total instantaneous internal tank pressure at a tank boundary point
- p_o = vapor pressure or the relief valve pressure setting
- ρ = fluid density, cargo or ballast
- h_t = total pressure head defined by the height of the projected fluid column in the direction of the total instantaneous acceleration vector
- $a_{x,y,z}$ = longitudinal, lateral, and vertical wave-induced accelerations relative to the craft's axis system at a point on a tank's boundary
- $g_{x,y,z}$ = longitudinal, lateral, and vertical components of gravitational accelerations relative to the craft's axis system at a tank boundary point

7.3.2(b) *Roll and Pitch Motions.* The influence of ship motions on tank pressures is to be taken into account using the maximum pitch and roll angles. As reflected in the previous formulations, the inclination of the tank due to craft roll and pitch is to be considered in the calculation of the hydrostatic pressure. The direction of gravitational forces in the ship-fixed coordinate system varies with roll and pitch, resulting in a change in pressure head and a corresponding change in the static pressure.

7.3.2(c) *Simultaneously Acting Tank Pressure.* At each wave condition, for each load case described in 3-1-3/3.5, simultaneously acting tank pressures (quasi-static and dynamic) are to be calculated. Each wave condition is defined by wave amplitude, frequency, heading angle and wave crest position, as explained in 3-1-3/3.5. Using the wave amplitude and phase angle determined based on the RAO of a DLP, the simultaneously acting tank pressure is to be calculated for the instant when the maximum value of the DLP occurs. These internal tank pressures are to be used in the structural finite element model.

7.3.3 Inertia Force of Lumped Structural Mass

The inertia force, or point load, of a structural mass, such as deck equipment or cargo, can be determined by the following equation:

$$F = m(A_t)$$

where

$$\begin{aligned} F &= \text{inertial load of the item} \\ m &= \text{mass of the lumped weight of the structural member} \\ A_t &= \text{amplitude of the acceleration RAO} \end{aligned}$$

For finite element models, the inertia forces in three (global) directions are to be calculated and applied. For a first-principles analysis, the inertia force in the vertical direction is to be calculated and applied.

9 Structural Response

9.1 Global Response

The global bending moments developed in 3-1-3/7.1 can either be applied to the requirements in 3-2-1/1.1.2(e), 3-2-1/1.5, 3-2-1/1.9.4, and 3-2-1/3.5 or to a global finite element model as outlined in this paragraph.

9.1.1 General

The load cases of 3-1-3/3.5 are to be applied to the global structural analysis model described in 3-1-3/9.1.4. Each load case is to include the hydrostatic and still-water load components that have not otherwise been directly included in the load component determination performed in accordance with 3-1-3/7.3.1 and 3-1-3/7.3.3. These hydrostatic or still-water components are to be included in the hydrostatics analysis.

9.1.2 Equilibrium Check

The model of the hull girder structure should be close to equilibrium when all the loads (static and dynamic) are applied.

The unbalanced forces in the model's global axis system for each load case need to be determined and resolved. The magnitudes of the unbalanced forces, and the procedure used to balance the structural model in equilibrium is to be fully documented.

9.1.3 General Modeling Considerations

To the maximum extent practicable, the overall model of the hull structure should be comprised of the entire hull. There is also to be sufficient compatibility between the hydrodynamic and structural models so that the application of fluid pressures onto the finite element mesh of the structural model can be done appropriately.

For the load component types and structural responses of primary interest, analysis software formulations derived from linear idealizations are sufficient. Enhanced bases of analysis may be required so that non-linear loads, such as hull slamming, may be required. The adequacy of the selected software is to be demonstrated to the satisfaction of ABS.

The results of overall (global) model analysis are to be directly employed in the creation and analysis of the required finer mesh, local structural models. Appropriate boundary conditions determined in the larger scale model are to be imposed in the local models to assure appropriate structural continuity and load transfer between the various levels of models.

9.1.4 Analysis of the Global Hull Structure

The global structural and load model is to be as detailed and complete as possible. The stress results of the global model are used only to assess the hull girder plating of the deck (and wet deck for multi-hulled craft), side shell, bottom, inner bottom, longitudinal bulkheads, transverse bulkheads and stools or deck box girders. The main supporting members of the hull girder may be evaluated using 2-D fine-mesh local models. In developing the 3-D global finite element model, the following requirements apply:

- i) The finite element model is to include all primary load-carrying members. Secondary structural members which may affect the overall load distribution are also to be included.
- ii) Structural idealization is to be based on the stiffness and anticipated response of the structure, not wholly on the geometry of the structure itself.
- iii) The relative stiffness between associated structural members and their anticipated response under the specified loading is to be considered.
- iv) A judicious selection of nodes, elements, and degrees of freedom is to be made to represent the stiffness and mass properties of the hull, while keeping the size of the model and required data generation within manageable limits. Lumping of plating stiffeners, use of equivalent plate thickness, and other techniques may be used for this purpose.
- v) The finite elements, whose geometry, configuration, and stiffness closely approximate the actual structure, can typically be of three types:
 - Truss or bar elements with axial stiffness only
 - Beam elements with axial, shear, and bending stiffness
 - Membrane plate elements, either triangular or quadrilateral.
- vi) When possible, the finite element structure is to be based on the use of gross or as-built scantlings.

9.3 Local Response

The local loads developed in 3-1-3/7.3 may be used in conjunction with the scantling requirements in Sections 3-2-3 and 3-2-4. For local structure that forms a grillage, or that is arranged in a manner not indicative of the principles given in the other Sections of this Guide, or structure that is being examined in conjunction with a finite element analysis may be reviewed using the following:

9.3.1 Non-Prismatic Beam Analysis

Beams that do not have uniform cross-sections may be analyzed using a non-prismatic beam program. The adequacy of the selected software is to be demonstrated to the satisfaction of ABS. In developing the non-prismatic beam model, the following requirements apply:

- i) The program is to be capable of calculating the shear and bending moment at all locations along the length of the beam.
- ii) Section properties of the beam are to be inputted into the program to resemble the actual construction of the beam and are to have a maximum segment length of 300 mm (1 foot).
- iii) The loads for the beam may be derived from Section 3-2-2 or 3-1-3/7.
- iv) The boundary conditions of the beam are to reflect the structural arrangement.

9.3.2 Grillage or Plane Frame Analysis

Structure that forms a grillage, or an area of structure that is arranged in a manner that is different from the principles of this Guide, may be analyzed using a grillage or plane frame analysis program. The adequacy of the selected software is to be demonstrated to the satisfaction of ABS. In developing the grillage or plane frame model, the following requirements apply:

- i) The beam elements in the model are to be arranged to reflect all of the structure in the area under consideration.
- ii) The program is to be capable of applying off-axis loads to the elements and nodes.
- iii) The program is to be capable of calculating and reporting the bending moments and shear forces at each node.
- iv) The loads for the model may be derived from Section 3-2-2 or 3-1-3/7.
- v) The boundary conditions of the model are to reflect the structural arrangement. Boundary conditions that model symmetry will be specially considered.

9.3.3 Local Fine Mesh Model from Global 3-D Model

Detailed local stresses are to be determined by fine mesh FEM analysis of local structures, based on the results of the global 3-D analysis.

The requirements for developing the 3-D coarse mesh global model in 3-1-3/9.3.4 are also applicable to the development of the 2-D fine-mesh models. In developing the 2-D fine mesh model, the following requirements apply:

- i) The mesh size of the 2-D finite element model are to be determined by adequately modeling the stiffness of the individual structural members forming the local structure.
- ii) In modeling a local transverse structure, the web plating is modeled by membrane plates, using both quadrilateral and triangular elements. Stiffeners on the web plating, such as panel breakers, tripping brackets, flat bar stiffeners, etc., and the face plates of the webs are modeled by rod elements of equivalent cross sectional areas. Where face plates on brackets are tapered at the ends, the area of the rod elements should be reduced accordingly. The out-of-plane hull girder plating (i.e., deck, side shell, bottom shell, girders, etc.) is also to be modeled by rod elements, using an appropriate effective width.
- iii) The mesh size used should be adequate to represent the overall stiffness of the considered local structure as a whole, such that smooth stress distributions in the structure can be obtained.
- iv) Finer meshes are to be used in the probable high stressed areas in order to obtain more accurate stress distributions for these areas. The use of a uniform mesh with smooth transition and with avoidance to abrupt changes in mesh sizes is recommended.
- v) In laying out the mesh, the shapes of membrane elements created are to be as regular as possible. The aspect ratios of plate elements are to be kept within 2:1. Elements with an aspect ratio higher than 5:1 may be used for convenience of modeling in way of low stress areas, or areas of low interest.
- vi) The grid line spacing and element sizes for the transverse section can be determined by the spacing of the longitudinals on the bottom shell, inner bottom, and topside tank. The grid lines can either be in line with the longitudinals, or for a finer mesh, an additional one division can be added between the longitudinal spacing.
- vii) Cutout openings for longitudinals and access holes need not be considered in the 2-D models. This is also applies to all lightening holes or other small openings in the webs.
- viii) The stiffeners, panel breakers, and ribs that prevent local buckling that are parallel to the principal direction of stress are to be included in the model.

Boundary displacements obtained from the 3-D global analysis are to be used as boundary conditions in the fine mesh analysis. As applicable, the fine mesh models are to include at least the following local structures:

- A number of transverse web frames
- Centerline longitudinal girder
- Side longitudinal girder
- Horizontal stringers of watertight transverse bulkhead
- Other areas of high stress indicated from the 3-D global analysis.

Where the 3-D global analysis is not comprehensive enough to determine adequately the total stress in the longitudinal plating (e.g., deck and shell) and transverse bulkhead plating of the craft, additional analyses may be required. Such analyses may not require the performance of fine mesh FEM analysis, where the needed results can be provided by another acceptable method.

9.3.4 Local Fine Mesh Model without Global 3-D Model

Structure that forms a grillage or an area of structure that is arranged in a manner different from the principles of the Guide may be analyzed using a local finite element model. The adequacy of the selected software is to be demonstrated to the satisfaction of ABS. In developing the local finite element model, the following requirements apply:

- i) The requirements in 3-1-3/9.3.4 are to be applied as applicable.
- ii) The loads for the model may be derived from Section 3-2-2 or 3-1-3/7.
- iii) The boundary conditions of the model are to reflect the structural arrangement. Boundary conditions that model symmetry will be specially considered.

11 Structural Acceptability

11.1 Beam, Grillage, or Plane Frame Analysis

The allowable bending stress for elements in beam, grillage or plane frame models is given in 3-2-4/Table 1 or 3-2-4/Table 2. The allowable shear stress for aluminum and steel elements is $0.5\tau_y$ ($0.75\tau_y$ for bottom primary structures) where τ_y is the minimum shear yield strength of the material. For aluminum structure, τ_y is to be in the welded condition. The allowable shear stress for composite members is $0.4\tau_u$, where τ_u is the lesser of the ultimate shear strength in either the warp or fill of the web laminate.

11.3 Finite Element Analysis

11.3.1 General

The adequacy of the finite element analysis results is to be assessed for the failure modes of material yielding and buckling. The requirements in this section are for steel, aluminum and FRP craft. The acceptance criteria for craft constructed of other materials will be specially considered.

11.3.2 Yielding

For a plate element subjected to biaxial stress, a specific combination of stress components, rather than a single maximum normal stress component constitutes the limiting condition. In this regard, the total equivalent stress is to be based on the Hencky von-Mises criterion as the following equation:

$$\sigma_e = [\sigma_x^2 + \sigma_y^2 - \sigma_x\sigma_y + 3\tau_{xy}^2]^{1/2}$$

where

- σ_x = normal stress in the x coordinate direction of the element
- σ_y = normal stress in the y coordinate direction of the element
- τ_{xy} = in-plane shearing stress

The total equivalent stress (Hencky von-Mises stress) is to be less than or equal to the following design stress:

Steel:	$0.95\sigma_y$
Aluminum:	$0.85\sigma_y$
FRP:	$0.37\sigma_u$

where σ_y is the yield strength for steel structures or the welded yield strength for aluminum structure, and σ_u is the ultimate tensile or compressive strength of the laminate, whichever is less.

Component stresses (σ_x , σ_y , τ_{xy}) are to be less than or equal to allowable local structure design stress.

11.3.3 Design Global Hull Girder Stresses

The design stresses are as follows:

- Global Longitudinal Strength of All Hull Types

$$\sigma_a = \text{design longitudinal bending stress, } f_p/CQ \text{ N/mm}^2 \text{ (kgf/mm}^2, \text{ psi)}$$

$$\tau_a = \text{design shear stress, } 110/Q \text{ N/mm}^2 \text{ (1.122/Q tf/cm}^2, \text{ 7.122/Q Ltf/in}^2)$$

$$f_p = 17.5 \text{ kN/cm}^2 \text{ (1.784 tf/cm}^2, \text{ 11.33 Ltf/in}^2)$$

$$C = \begin{cases} 1.0 & \text{for steel craft} \\ 0.90 & \text{for aluminum craft} \\ 0.80 & \text{for fiber-reinforced plastic craft} \end{cases}$$

Q for steel:

$$Q = \begin{cases} 1.0 & \text{for ordinary strength steel} \\ 0.78 & \text{for grade H32 steel} \\ 0.72 & \text{for grade H36 steel} \end{cases}$$

Q for aluminum:

$$Q = 0.9 + q_5 \text{ but not less than } Q_o$$

$$q_5 = 115/\sigma_y \text{ (12}/\sigma_y, \text{ 17000}/\sigma_y)$$

$$Q_o = 635/(\sigma_y + \sigma_u) \text{ [65}/(\sigma_y + \sigma_u), \text{ 92000}/(\sigma_y + \sigma_u)]$$

$$\sigma_y = \text{minimum yield strength of unwelded aluminum in N/mm}^2 \text{ (kgf/mm}^2, \text{ psi)}$$

(not to be greater than $0.7\sigma_u$)

$$\sigma_u = \text{minimum ultimate strength of welded aluminum in N/mm}^2 \text{ (kgf/mm}^2, \text{ psi)}$$

Q for fiber reinforced plastic:

$$Q = 400/0.75\sigma_u \text{ (41}/0.75\sigma_u, \text{ 58000}/0.75\sigma_u)$$

$$\sigma_u = \text{minimum ultimate tensile or compressive strength, whichever is less, verified by approved test results, in N/mm}^2 \text{ (kgf/mm}^2, \text{ psi)}. \text{ See Section 2-6-5.}$$

Strength properties in the longitudinal direction of the craft are to be used.

- Global Transverse Strength of Multihulls

$$\sigma_a = \text{design transverse bending stress, } 0.66\sigma_y \text{ for aluminum and steel craft and } 0.33\sigma_u \text{ for FRP craft, in N/mm}^2 \text{ (kgf/mm}^2, \text{ psi)}$$

$$\sigma_{ab} = \text{design torsional or combined stress, } 0.75\sigma_y \text{ for aluminum and steel craft and } 0.367\sigma_u \text{ for FRP craft, in N/mm}^2 \text{ (kgf/mm}^2, \text{ psi)}$$

$$\tau_a = \text{design transverse shear stress, } 0.38\sigma_y \text{ for aluminum and steel craft and } 0.40\tau_u \text{ for FRP craft, in N/mm}^2 \text{ (kgf/mm}^2, \text{ psi)}$$

$$\sigma_y = \text{minimum yield strength of the material, in N/mm}^2 \text{ (kgf/mm}^2, \text{ psi)}. \text{ For aluminum the yield strength is to be for the unwelded condition and not to be greater than } 0.7\sigma_{uw}$$

$$\sigma_u = \text{minimum tensile or compressive strength, whichever is less, in N/mm}^2 \text{ (kgf/mm}^2, \text{ psi)}$$

$$\sigma_{uw} = \text{ultimate tensile strength of material in the welded condition, in N/mm}^2 \text{ (kgf/mm}^2, \text{ psi)}$$

- δ_m = maximum deflection for FRP craft, $(\sigma_d/E)L_p$, in m (in.)
- τ_u = minimum ultimate through thickness shear strength, in N/mm² (kgf/mm², psi)
- L_l = mean span of cross structure, in cm (in.), as indicated in 3-2-A2/Figure 2
- E = tensile or compressive modulus of the FRP laminate, whichever is lesser, in N/mm² (kgf/mm², psi)

PART

3

CHAPTER 1 General

SECTION 4 Guide for Finite Element Analysis

1 General

The intent of this section is to provide guidance on the use on fine element methods (FEM) for evaluating linear response of hull structural components, equipment foundations and reinforcement structure to applied loads.

Finite element methods can be applied with varying level of detail and complexity to determine stress levels, deflection magnitudes and other parameters of structural components. The choice of the type of finite element and evaluation criteria should match the desired level of detail, loading scenario, boundary conditions and complexity of the structural component.

3 Structural Modeling

3.1 Finite Element Types

The choice of the type of finite element is guided by the complexity of the structural system or component being analyzed, the level of detail desired and the outcomes measured. Two node line element and three or four membrane/plate element are considered sufficient for representation of a structure and requirements in this appendix assumes the use of such element types in the models. Higher order elements may also be applied. Details of basic element types are given in 3-1-4/Table 1.

TABLE 1
Finite Element Type

Rod (or truss) element	Line element with axial stiffness only and constant cross-sectional area along length of the element
Beam element	Line element with axial, torsional and bi-directional shear and bending stiffness and with constant properties along the length of the element
Membrane (or plane-stress) element	Plate element with in-plane stiffness and with constant thickness
Shell (or bending plate) element	Plate element with in-plane and out-of-plane bending stiffness and with constant thickness

3.3 Model Types

3.3.1 Beam/Grillage Model

Beam/grillage models comprise of entirely of beam and rod elements, and are suitable for the solution of simple to more elaborate beam problems of one, two or three-dimensional configuration. Examples where such models could be applied are for deck beams, girders, floors, and bulkhead stiffening. Such models provide bending moment and shear force distributions, axial, bending and shear stresses, and deflection magnitudes.

3.3.2 Plate Element Model

Plate element models are applied in cases where a precise representation of the geometry of the structural component or system is necessary, the complexity of the structure warrants it, or when the desired structural response cannot be determined from beam or grillage models.

3.5 Modeling Guidance

- i) The model should include, as applicable, all primary load-carrying members of the structure being analyzed. Secondary structural members that may significantly affect load distributions and local response of the primary members may also be appropriately included in the model.
- ii) For beam elements, cross sectional properties are to be based on that of effective width of the attached plating. The effective width of plating of beam elements is not to exceed the sum of one-half of the spacing on either side of the structural member or $1/3$ of the unsupported span of the member, whichever is less.
- iii) Plate element meshing is to follow the stiffening system as far as practicable. The mesh size used should be adequate to represent the overall stiffness of the considered structure. For meshing of large systems such as deck, shell or bulkhead plate/framing systems, the mesh size is to not exceed the spacing between the frames. The mesh should be progressively and smoothly refined to capture structural details where important or found necessary.
- iv) At least three elements are to be used, where practical, to model webs of primary supporting members such as girders, transverses, stringers and floors. Rod elements may be used to model flanges of primary supporting members and brackets. The cross sectional area of rods representing sniped or tapered flanges is to be considered proportionally using an average area over the length of the element.
- v) The aspect ratio of plate elements, in general, is not to exceed three. The use of triangular plate elements is to be kept to a minimum.
- vi) Shell elements are to be used for plate elements subjected to lateral loading.

3.7 Boundary Conditions

Boundary conditions applied are to reflect, as closely as possible, the actual support conditions of the structure.

The extent of model should be sufficient to establish proper boundary conditions. Where the model has been extended to points well away from the areas of interest within the model, boundary conditions may be reasonably simplified, for example assuming fully fixed conditions for plate elements models.

3.9 Loads

Loads applied on a model are to be as required by the relevant rule or the design loads of the structural member, whichever is greater.

In addition to static loads, other loads such as hull girder and dynamic loads arising out of acceleration, ship motion, etc. are to be considered where applicable and relevant.

In typical cases, it is not necessary to consider the self weight of the structure, unless it is expected to be a significant component of the loads acting on the structure.

Loads are to be applied in a manner so as to match, as closely as possible, the expected distribution and manifestation of the load within the structure in the actual situation.

3.11 Stress Criteria

Unless otherwise specified in this Guide or relevant regulations, individual stress components and, as applicable, direct combinations of such stresses in beam or grillage models are not to exceed the allowable stress F .

$$F = F_y/FS$$

where

F_y = specified minimum yield strength of the material

FS = Factor of Safety

For static loadings:

- = 1.67 for axial or bending stress
- = 2.50 for shear stress

For loads combining static and dynamic:

- = 1.25 for axial or bending stress
- = 1.88 for shear stress

For plate element models, and unless otherwise specified in this Guide or relevant regulations, the Von-Mises equivalent stress is not to exceed the limits specified in 3-2-20/Table 2 for the specific mesh size.

TABLE 2
Stress Limits for Plate Element Models

Mesh Size	Stress Limit
1 × stiffener spacing (SS)	0.90 $S_m F_y$
$\frac{1}{2} \times SS$	0.95 $S_m F_y$
$\frac{1}{3} \times SS$	1.00 $S_m F_y$
$\frac{1}{4} \times SS$ ⁽¹⁾	1.06 $S_m F_y$
$\frac{1}{5} \times SS \sim \frac{1}{10} \times SS$ ⁽¹⁾	1.12 $S_m F_y$

Notes:

- 1 Stress limits greater than 1.00 $S_m F_y$ are to be restricted to small areas in way of structural discontinuities.
- 2 S_m = 1.0 for mild steel
 = 0.95 for HT 32
 = 0.908 for HT 36
- 3 For intermediate mesh size, the stress limit may be obtained by linear interpretation
- 4 For longitudinally effective structure that is modeled without the hull girder loads, the allowable stresses are to be decreased by 10%

PART
3

CHAPTER **2 Hull Structures and Arrangements**

CONTENTS

SECTION 1	Primary Hull Strength.....	45
1	Longitudinal Hull Girder Strength – Monohulls	45
1.1	Section Modulus	45
1.3	Extension of Midship Section Modulus	49
1.5	Moment of Inertia.....	49
1.7	Section Modulus and Moment of Inertia Calculation.....	50
1.9	Hull Girder Shear Strength Calculation – For Craft 61 m (200 ft) in Length and Over	51
1.11	Hull Girder Torsional Loads	53
3	Primary Hull Strength – Twin-Hulled Craft.....	53
3.1	Longitudinal Hull Girder Strength.....	53
3.3	Catamaran Transverse Loadings.....	53
3.5	Transverse Strength for Catamarans and Surface Effect Craft	54
3.7	Items Included in Transverse Moment of Inertia and Section Modulus Calculation	54
3.9	Craft with More Than Two Hulls	55
3.11	Hull Girder Torsional Loads	55
5	Strength Considerations for Hydrofoil Borne Craft	55
5.1	Longitudinal Strength.....	55
5.3	Calculation of Loads from Hydrofoil Appendages.....	55
7	Effective Decks	56
9	Operating Manual	56
TABLE 1	Minimum Vertical Acceleration.....	48
TABLE 2	Factor, <i>K</i>	50
FIGURE 1	Sign Convention	47
FIGURE 2	Distribution Factor <i>M</i>	49
FIGURE 3	Distribution Factor <i>F</i> ₁	51
FIGURE 4	Distribution Factor <i>F</i> ₂	52
SECTION 2	Design Pressures	57
1	Monohulls.....	57
1.1	Bottom Design Pressure	57
1.3	Side and Transom Structure, Design Pressure	60
3	Multi-Hull and Surface Effect Craft	61
3.1	Bottom Design Pressure.....	62
3.3	Side and Transom Structure, Design Pressure	62
3.5	Wet Deck or Cross Structure	63

5	Deck Design Pressures – All Craft	64
7	Superstructures and Deckhouses – All Craft.....	64
9	Bulkhead Structure, Design Pressure – All Craft.....	64
9.1	Tank Boundaries	64
9.3	Watertight Boundaries	64
11	Operational Loads.....	65
11.1	Human Loads.....	65
11.3	Helicopter Decks	65
TABLE 1	Design Significant Wave Heights, $h_{1/3}$, and Speeds, V	59
TABLE 2	Minimum Values for F_D ($L \leq 24$ m, 79 ft).....	59
TABLE 3	Deck Design Pressures, p_d	66
TABLE 4	Superstructures and Deckhouses Design Pressures	66
FIGURE 1	Deadrise, Flare, and Entry Angles	60
FIGURE 2	Decks, Superstructures, and Deckhouse Pressures	67
FIGURE 3	Design Area Factor F_D	67
FIGURE 4	Vertical Acceleration Distribution Factor K_V	68
FIGURE 5	Vertical Acceleration Distribution Factor F_V	68
FIGURE 6	Wet Deck Pressure Distribution Factor F_I	69

SECTION 3 Plating **70**

1	Aluminum or Steel.....	70
1.1	General.....	70
1.3	Thickness	70
1.5	Buckling Criteria	73
1.7	Water Jet Tunnels and Transverse Thruster Tubes	76
1.9	Decks Provided for the Operation or Stowage of Vehicles	76
3	Aluminum Extruded Planking, Sandwich Panels and Corrugated Panels	77
3.1	Aluminum Extruded Planking	77
3.3	Sandwich Panels.....	78
3.5	Corrugated Panels	79
5	Fiber Reinforced Plastic.....	79
5.1	General.....	79
5.3	Fiber Reinforcement.....	80
5.5	Single Skin Laminate.....	80
5.7	Sandwich Laminate	82
7	Plating Subject to Specific Payloads	86

TABLE 1	Aspect Ratio Coefficient for Isotropic Plates.....	71
TABLE 2	Design Stress, σ_a , Aluminum and Steel.....	71
TABLE 3	Buckling Coefficients m_1 and m_2	75
TABLE 4	Design Stresses for FRP, σ_a	81
TABLE 5	Aspect Ratio Coefficient for Isotropic Plates.....	82
TABLE 6	Coefficient ν for FRP Sandwich Panels Shear Strength.....	85

TABLE 7	Core Shear Design Strength.....	85
TABLE 8	87
FIGURE 1	Values for β	77
FIGURE 2	Extruded Planking.....	78
SECTION 4	Internals.....	88
1	Aluminum and Steel.....	88
1.1	General.....	88
1.3	Strength and Stiffness.....	88
1.5	Elastic Buckling of Longitudinal Members.....	90
1.7	Corrugated Panels.....	94
1.9	Web Thickness.....	95
1.11	Attachments.....	95
1.13	Direct Analysis Methods.....	96
1.15	Decks Exposed to Vehicle Loads.....	96
1.17	Tripping Brackets and Stiffeners.....	96
3	Fiber Reinforced Plastic.....	96
3.1	General.....	96
3.3	Fiber Reinforcement.....	96
3.5	Strength and Stiffness.....	96
3.7	Proportions.....	97
3.9	Buckling.....	97
3.11	Tripping Brackets and Stiffeners.....	98
5	Stanchions.....	98
5.1	General.....	98
5.3	Stanchion Analysis.....	98
5.5	Stanchion Load.....	98
5.7	Permissible Load.....	98
5.9	FRP Stanchions.....	99
5.11	Support by Bulkheads.....	99
7	Internals Subject to Specific Payloads.....	99
TABLE 1	Design Stress, σ_a	89
TABLE 2	Maximum Stresses.....	99
FIGURE 1	Transverse Side Frame.....	89
FIGURE 2	Transverse Side Frame.....	89
FIGURE 3	Corrugated Bulkhead.....	94
FIGURE 4	Corrugated Bulkhead End Connections.....	94
SECTION 5	Hull Structural Arrangement.....	100
1	Structural Arrangement – All Materials.....	100
1.1	Framing, Webs, Girders, and Non-tight Structural Bulkheads.....	100
1.3	Watertight Bulkheads.....	101
1.5	Tanks.....	103

1.7	Decks	103
1.9	Means of Escape.....	103
1.11	Double Bottoms.....	104
1.13	Doors, Hatches, Scuttles, and Manhole Covers.....	104
1.15	Helicopter Decks	104
1.17	Compensation	105
3	Structural Arrangements – Additional Requirements for Steel and Aluminum Alloys	105
3.1	Shell Plating	105
5	Structural Arrangements – Additional Requirements for Fiber Reinforced Plastic Hulls	105
5.1	Tanks.....	105
FIGURE 1	Reference Point of Vessels with Bulbous Bow	102
FIGURE 1A	103
FIGURE 1B	103

SECTION 6 Arrangement, Structural Details, and Connections 106

1	Structural Details.....	106
1.1	Aluminum and Steel	106
1.3	Fiber Reinforced Plastic	107
3	Welded and Mechanical Connections	114
3.1	Steel and Aluminum	114
3.3	Fiber Reinforced Plastic	114
3.5	Backing Bars and Tapping Plates	116
5	FRP Deck-to-Hull Joints.....	116
5.1	Weather Joints	116
5.3	Interior Joints.....	116
7	FRP Shell Details	118
7.1	Keels	118
7.3	Chines and Transoms	119

TABLE 1	Deck-to-Hull Joints	117
---------	---------------------------	-----

FIGURE 1	Piping or Opening through Foam Filled Space.....	107
FIGURE 2	Proportions of Stiffeners	108
FIGURE 3	Premolded FRP Form	109
FIGURE 4	Premolded Stiffener	109
FIGURE 5	Connection of Longitudinals to Transverses.....	110
FIGURE 6	Engine Foundations	111
FIGURE 7	Deck Fittings	112
FIGURE 8	Through Hull Penetration – Solid Laminate	112
FIGURE 9	Through Hull Penetration – Sandwich Laminate	113
FIGURE 10	Boundary Angles for FRP Components.....	114
FIGURE 11	Examples of Deck-to-Hull Weather Joints	118
FIGURE 12a	Plate Keel in One-piece Hull	118

	FIGURE 12b	Plate Keel in Hull Molded in Halves	119
	FIGURE 13	Vertical Keel or Skeg.....	119
	FIGURE 14a	Chine or Transom – Single Skin Construction	119
	FIGURE 14b	Chine or Transom – Sandwich Construction	120
	FIGURE 14c	Stepped Chine – Foam Wedge Option	120
	FIGURE 14d	Stepped Chine – Putty Radius.....	121
SECTION 7	Keels, Stems, Shaft Struts, and Propeller Nozzles.....		122
1	Materials.....		122
	1.1	Ordinary Strength Steels	122
	1.3	High Strength Steels and Aluminum Alloys	122
	1.5	Fiber Reinforced Plastic.....	122
3	Keels		122
	3.1	Bar Keels.....	122
	3.3	Plate Keels	123
5	Stems		123
	5.1	Bar Stems.....	123
	5.3	Plate Stems	123
7	Stern Frames		123
9	Shaft Struts		123
	9.1	General.....	123
	9.3	V Strut.....	124
	9.5	I Strut.....	124
	9.7	Strut Length	124
	9.9	Strut Barrel	124
11	Propeller Nozzles		125
	11.1	Application	125
	11.3	Design Pressure	125
	11.5	Nozzle Cylinder.....	125
	11.7	Nozzle Section Modulus	126
	11.9	Welding Requirement.....	127
	TABLE 1	Coefficient c	125
	TABLE 2	Coefficient ε	125
	TABLE 3	Coefficient c_n	126
	TABLE 4	Corrosion Allowance t_c	126
	FIGURE 1	Propeller Nozzle Section View.....	127
SECTION 8	Rudders		128
1	General		128
	1.1	Application	128
	1.3	Rudder and Rudder Stock Materials.....	128
	1.5	Expected Torque	128
	1.7	Rudder Stops.....	129

3	Rudder Design Force	129
3.1	Rudder Blades without Cutouts	129
3.3	Rudder Blades with Cutouts	129
5	Rudder Design Torque.....	132
5.1	General.....	132
5.3	Rudder Blades without Cutouts	132
5.5	Rudders Blades with Cutouts	133
5.7	Trial Conditions	133
7	Rudder Stocks	133
7.1	Upper Rudder Stocks	133
7.3	Lower Rudder Stocks	133
7.5	Rudder Stock Sealing.....	134
7.7	Bending Moments	134
9	Flange Couplings	135
9.1	General.....	135
9.3	Horizontal Couplings	136
9.5	Vertical Couplings	136
11	Tapered Stock Couplings.....	137
11.1	Coupling Taper.....	137
11.3	Keyed Fitting	138
11.5	Keyless Fitting	138
11.7	Locking Nut	138
13	Pintles	139
13.1	General.....	139
13.3	Diameter.....	139
13.5	Shear and Bearing Forces.....	140
15	Supporting and Anti-Lifting Arrangements.....	140
15.1	Bearings	140
15.3	Rudder Carrier.....	142
15.5	Anti Lifting Devices.....	142
17	Double Plate Rudder.....	142
17.1	Strength.....	142
17.3	Side, Top and Bottom Plating.....	144
17.5	Diaphragm Plates.....	144
17.7	Watertightness	144
19	Single Plate Rudders	145
19.1	Mainpiece Diameter	145
19.3	Blade Thickness	145
19.5	Arms.....	145
21	Shelled Rudder Blades	145
TABLE 1A	Coefficient k_c for Ordinary Rudders.....	130
TABLE 1B	Coefficient k_c for High-Lift/Performance Rudders	130
TABLE 2	Coefficient k_ℓ	132
TABLE 3	Coefficient α	132
TABLE 4	Minimum Bearing Force B_{\min}	139
TABLE 5	Bearing Reaction Force	141
TABLE 6	Allowable Bearing Surface Pressure	142

FIGURE 1	Rudder Blade without Cutouts	131
FIGURE 2	Rudder Blade with Cutouts	131
FIGURE 3	Tapered Couplings.....	137
FIGURE 4.....		143

SECTION 9 Protection of Deck Openings 146

1	General	146
3	Position of Deck Openings.....	146
5	Hatchway Coamings, Companionway Sills and Access Sills	146
5.1	Coaming and Sill Heights	146
7	Enclosed Superstructures.....	147
7.1	Closing Appliances	147
7.3	Sills of Access Openings	147
7.5	Means of Access	147
9	Hatchways Closed by Covers of Steel and Fitted with Gaskets and Clamping Devices	147
9.1	Strength of Covers.....	147
9.3	Means for Securing Weathertightness.....	148
9.5	Flush Hatch Covers	148
11	Hatchways Closed by Portable Covers in Lower Decks or within Fully Enclosed Superstructures	148
11.1	General.....	148
11.3	Steel Covers	148
11.5	Wheel Loading.....	148
13	Hatchways Closed by Covers of Materials Other Than Steel.....	148
15	Small Hatches on the Exposed Fore Deck	149
15.1	Application	149
15.3	Strength	149
15.5	Primary Securing Devices	149
15.7	Requirements for Primary Securing.....	149
15.9	Secondary Devices.....	150
17	Hatchways within Open Superstructures	152
19	Hatchways within Deckhouses	152
21	Machinery Casings	153
21.1	Arrangement.....	153
21.3	Scantlings	153
23	Miscellaneous Openings in Freeboard and Superstructure Decks	153
23.1	Manholes and Scuttles	153
23.3	Other Openings	153
23.5	Escape Openings	153
23.7	Chain Pipe Opening.....	153

TABLE 1	Coamings and Sill Heights.....	146
---------	--------------------------------	-----

TABLE 2	Scantlings for Small Steel Hatch Covers on the Fore Deck	150
---------	---	-----

FIGURE 1	Arrangement of Stiffeners	151
FIGURE 2	Example of Primary Securing Method	152

SECTION 10	Protection of Shell Openings	154
1	Cargo, Gangway, or Fueling Ports	154
1.1	Construction	154
1.3	Location	154
3	Bow Doors, Inner Doors, Side Shell Doors and Stern Doors	154
3.1	General	154
3.3	Arrangement	154
5	Securing, Locking and Supporting of Doors	155
5.1	Definitions	155
7	Securing and Supporting Devices	155
7.1	General	155
7.3	Bow Doors	155
7.5	Side Shell and Stern Doors	155
9	Securing and Locking Arrangement	156
9.1	General	156
9.3	Operation	156
9.5	Indication/Monitoring	156
11	Tightness	157
11.1	Bow Doors	157
11.3	Inner Doors	157
11.5	Side Shell and Stern Doors	157
13	Bow Door Scantlings	157
13.1	General	157
13.3	Primary Structure	157
13.5	Secondary Stiffeners	157
13.7	Plating	157
13.9	Securing and Supporting Devices	157
13.11	Visor Door Lifting Arms and Supports	158
15	Inner Door Scantlings	158
15.1	General	158
15.3	Primary Structure	158
15.5	Securing and Supporting Devices	158
17	Side Shell Door and Stern Door Scantlings	159
17.1	General	159
17.3	Primary Structure	159
17.5	Secondary Stiffeners	159
17.7	Plating	159
17.9	Securing and Supporting Devices	159
19	Bow Door Design Loads	160
19.1	External Pressure	160
19.3	External Forces	161
19.5	Visor Door Forces, Moments and Load Cases	162
19.7	Side-Opening Door Load Cases	164

21	Inner Door Design Loads	164
21.1	External Pressure	164
21.3	Internal Pressure	164
23	Side Shell and Stern Doors.....	164
23.1	Design Forces for Primary Members	164
23.3	Design Forces for Securing or Supporting Devices of Doors Opening Inwards.....	164
23.5	Design Forces for Securing or Supporting Devices of Doors Opening Outwards.....	164
25	Allowable Stresses.....	165
25.1	Primary Structure and Securing and Supporting Devices.....	165
25.3	Steel Securing and Supporting Devices Bearing Stress	165
25.5	Tensile Stress on Threaded Bolts.....	166
27	Operating and Maintenance Manual.....	166
27.1	Manual.....	166
27.3	Operating Procedures.....	166
FIGURE 1	Entry and Flare Angles	160
FIGURE 2	Definition of α_m and β_m	162
FIGURE 3	Visor Type Bow Door	163

SECTION 11	Bulwarks, Rails, Ports, Portlights, Windows, Ventilators, Tank Vents and Overflows	167
1	Bulwarks and Guard Rails	167
1.1	Location and Heights.....	167
1.3	Strength of Bulwarks.....	167
1.5	Guard Rails.....	167
1.7	Guard Rail Scantling Correction	169
1.9	Life Lines	170
3	Freeing Ports.....	170
3.1	Basic Area for Craft More Than 24 meters (79 feet) in Length	170
3.3	Basic Area for Craft Less Than 24 meters (79 feet) in Length.....	170
3.5	Trunks, Deckhouses and Hatchway Coamings	171
3.7	Superstructure Decks	171
3.9	Open Superstructures.....	171
3.11	Details of Freeing Ports	171
5	Portlights	171
5.1	Location	171
5.3	Construction	171
5.5	Testing.....	172
7	Windows.....	172
7.1	Construction	172
7.3	Testing.....	174
9	Ventilators, Tank Vents and Overflows.....	174
9.1	General.....	174
9.3	Ventilators.....	174
9.5	Tank Vents and Overflows.....	175
9.7	Ventilators, Tank Vents and Overflows on the Fore Deck	175

TABLE 1	Thickness of Tempered or Toughened Monolithic Glass Portlights	172
TABLE 2	173
TABLE 3	174
TABLE 4	760 mm (30 in.) High Tank Vents and Overflows Thickness and Bracket Standards	176
TABLE 5	900 mm (35.4 in.) High Ventilator Thickness and Bracket Standards.....	177
FIGURE 1	Guardrail Stanchion	168
FIGURE 2	Guardrail Stanchion	169

SECTION 12 Protective Coatings 178

1	General	178
3	Preparation	178
5	Protection of Steel.....	178
5.1	Preparation.....	178
5.3	All Spaces	178
5.5	Salt Water Ballast Space.....	178
5.7	Oil Spaces.....	178
7	Protection of Aluminum.....	179
7.1	General.....	179
7.3	Preparation.....	179
7.5	Coatings	179
7.7	Faying Surfaces – Aluminum to Aluminum.....	179
7.9	Faying Surface between Aluminum and Other Metals	179
7.11	Faying Surface between Aluminum and Non-metals.....	180
7.13	Corrosion of Wet Spaces.....	180
7.15	Service at Elevated Temperatures	180
7.17	Cathodic Protection for Corrosion Prevention	180
7.19	Stray Current Protection.....	180
7.21	Bi-material Joints.....	180
9	Protection of Fiber Reinforced Plastic	181
9.1	General.....	181
9.3	Preparation.....	181
9.5	Tanks.....	181
9.7	Cathodic Protection.....	181

SECTION 13 Welding, Forming and Weld Design 182

1	Fillet Welds	182
1.1	General.....	182
1.3	Tee Connections	182
1.5	Fillet Sizes and Spacing	183
1.7	Thin Plating	183
1.9	Length and Arrangement of Fillet	183
1.11	Fillet Weld Arrangements	183
3	Bi-material Joints	184
5	Alternatives	184

TABLE 1	Weld Factor <i>C</i>	185
FIGURE 1	184
APPENDIX 1	Guidelines for Calculating Bending Moment and Shear Force in Rudders and Rudder Stocks	186
1	Application.....	186
3	Spade Rudders	186
3.1	Rudder.....	186
3.3	Lower Stock.....	187
3.5	Moment at Top of Upper Stock Taper.....	187
3.7	Bearing Reaction Forces	187
5	Rudders Supported by Shoe-piece	188
5.1	Shear Force, Bending Moment and Reaction Forces	188
7	Rudders Supported by a Horn with One Pintle.....	189
7.1	Shear Force, Bending Moment and Reaction Forces	189
FIGURE 1	Spade Rudder	188
FIGURE 2	Rudder Supported by Shoe-piece.....	189
FIGURE 3	Rudder Supported by a Horn with One Pintle.....	190
APPENDIX 2	Guidance on Analysis of the Cross Deck Structure of a Multi-Hull Craft.....	191
1	Transverse Bending and Shear Stress.....	191
3	Center of Torsional Rotation	192
5	Maximum Bending Stress on Each Element	193
5.1	Deflection.....	193
5.3	Bending Moment.....	193
5.5	Maximum Stress.....	193
5.7	Maximum Shear Stress on Each Element	194
FIGURE 1	Typical Geometry of Centerline Section of Cross Deck.....	191
FIGURE 2	Span of Cross Structure	192
APPENDIX 3	Alternative Method for the Determination of “V” Shaft Strut Requirements.....	195
1	General	195
3	Loads and Moments Acting on Strut.....	195
5	Required Section Modulus of Strut at the Barrel	196
7	Required Section Modulus of Strut at the Hull.....	196
9	Requirements for Struts Constructed of Aluminum	196
FIGURE 1	Strut Dimensions.....	195

PART

3CHAPTER **2** **Hull Structures and Arrangements**SECTION **1** **Primary Hull Strength****1** **Longitudinal Hull Girder Strength – Monohulls**

The equations are, in general, valid for craft having breadths, B , not greater than twice their depths, D , as defined in Section 3-1-1. Finite element analysis of the longitudinal hull girder strength is an acceptable alternate analysis to the requirements in 3-2-1/1 through 3-2-1/5. The failure criteria, seaway loads, and finite element method is to be submitted for review.

1.1 **Section Modulus****1.1.1** All Craft

The required hull girder section modulus SM at amidships is to be not less than given by the following equation:

$$SM = C_1 C_2 L^2 B (C_b + 0.7) K_3 C Q \quad \text{cm}^2\text{-m (in}^2\text{-ft)}$$

where

$$\begin{aligned} C_1 &= 0.044L + 3.75 && L < 90 \text{ m} \\ &= 10.75 - \left(\frac{300 - L}{100} \right)^{1.5} && 90 \text{ m} \leq L \end{aligned}$$

$$\begin{aligned} C_1 &= 0.0134L + 3.75 && L < 295 \text{ ft} \\ &= 10.75 - \left(\frac{984 - L}{328} \right)^{1.5} && 295 \text{ ft} \leq L \end{aligned}$$

$$C_2 = 0.01 \text{ (0.01, } 1.44 \times 10^{-4}\text{)}$$

$$L = \text{length of craft, in m (ft), as defined in Section 3-1-1}$$

$$B = \text{breadth, in m (ft), as defined in Section 3-1-1}$$

$$V = \text{maximum speed in calm water, in knots, for the loading condition under consideration}$$

$$C_b = \text{block coefficient at the design draft, based on the length, } L, \text{ measured on the design load waterline. } C_b \text{ is not to be taken as less than 0.45 for } L < 35 \text{ m (115 ft) or 0.6 for } L \geq 61 \text{ m (200 ft). } C_b \text{ for lengths between 35 m (115 ft) and 61 m (200 ft) is to be determined by interpolation.}$$

$$K_3 = \left(0.70 + 0.30 \left[\frac{V/\sqrt{L}}{2.36} \right] \right) \quad \text{SI/MKS units,}$$

$$\left(0.70 + 0.30 \left[\frac{V/\sqrt{L}}{1.30} \right] \right) \quad \text{US Units;}$$

K_3 is not to be taken less than 1, nor more than 1.30.

$$C = \begin{array}{ll} 1.0 & \text{for steel craft} \\ 0.90 & \text{for aluminum craft} \\ 0.80 & \text{for fiber-reinforced plastic craft} \end{array}$$

Q for steel:

$$= \begin{array}{ll} 1.0 & \text{for ordinary strength steel} \\ 0.78 & \text{for grade H32 steel} \\ 0.72 & \text{for grade H36 steel} \end{array}$$

For other steel grades:

$$Q_{other} = 490/(\sigma_y + 0.66\sigma_u) [50/(\sigma_y + 0.66\sigma_u), 70900/(\sigma_y + 0.66\sigma_u)], \text{ where } \sigma_y \text{ is not to be greater than } 70\% \sigma_u$$

Q for aluminum:

$$= 0.9 + q_5 \text{ but not less than } Q_o$$

$$q_5 = 115/\sigma_y, (12/\sigma_y, 17000/\sigma_y)$$

$$Q_o = 635/(\sigma_y + \sigma_u), (65/(\sigma_y + \sigma_u), 92000/(\sigma_y + \sigma_u))$$

$$\sigma_y = \text{minimum yield strength of unwelded aluminum in N/mm}^2 \text{ (kgf/mm}^2, \text{ psi)} \\ \text{(not to be greater than } 0.7\sigma_u)$$

$$\sigma_u = \text{minimum ultimate strength of welded aluminum in N/mm}^2 \text{ (kgf/mm}^2, \text{ psi)}$$

Q for fiber reinforced plastic:

$$= 400/0.75\sigma_u, (41/0.75\sigma_u, 58000/0.75\sigma_u)$$

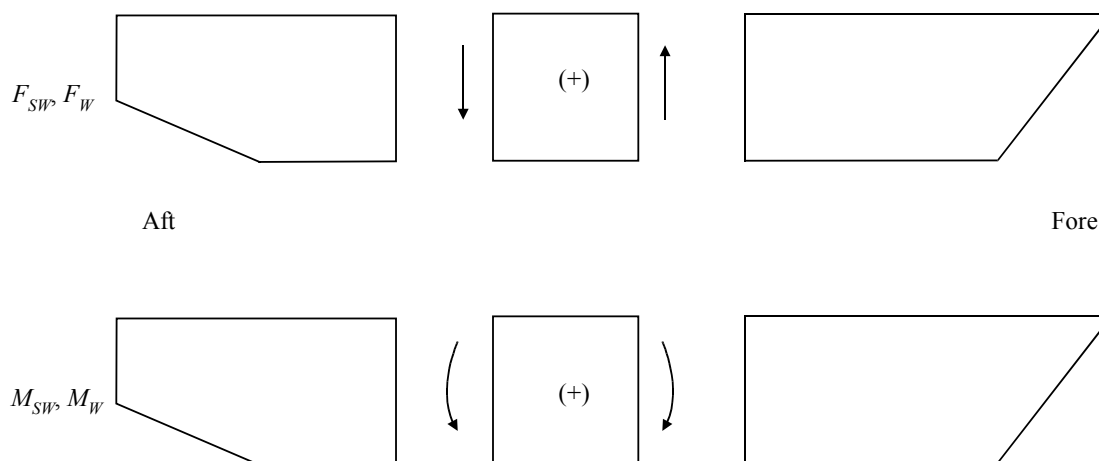
$$\sigma_u = \text{minimum ultimate tensile or compressive strength, whichever is less, verified by approved test results, in N/mm}^2 \text{ (kgf/mm}^2, \text{ psi). See Section 2-6-5. Strength properties in the longitudinal direction of the craft are to be used.}$$

1.1.2 Craft 61 m (200 ft) in Length and Over

In addition to meeting the above criteria in 3-2-1/1.1.1, craft of 61 m (20 ft) in length or greater are to comply with the following requirements:

1.1.2(a) Sign Convention of Bending Moment and Shear Force. The sign convention of bending moment and shear force is as shown in 3-2-1/Figure 1.

**FIGURE 1
 Sign Convention**



1.1.2(b) *Wave Bending Moment Amidships.* The wave bending moment, expressed in kN-m (tf-m, Ltf-ft), may be obtained from the following equations:

$$M_{ws} = -k_1 C_1 L^2 B (C_b + 0.7) \times 10^{-3} \quad \text{Sagging Moment}$$

$$M_{wh} = +k_2 C_1 L^2 B C_b \times 10^{-3} \quad \text{Hogging Moment}$$

where

$$k_1 = 110 \text{ (11.22, 1.026)}$$

$$k_2 = 190 \text{ (19.37, 1.772)}$$

C_1 , L , B and C_b are as defined in 3-2-1/1.1.1.

1.1.2(c) *Still Water Bending Moment.* The maximum still water bending moment in both the hogging and sagging condition is to be submitted. In case the detailed information is not available in the early stages of design, or the still water bending moment is not required to be submitted, the still water bending moment in kN-m (Ltf-ft) can be determined by the following:

$$M_{sws} = 0 \quad \text{Sagging Moment}$$

$$M_{swh} = 0.375 f_p C_1 C_2 L^2 B (C_b + 0.7) \quad \text{Hogging Moment}$$

where

$$f_p = 17.5 \text{ kN/cm}^2, \text{ (1.784 tf/cm}^2, \text{ 11.33 Ltf/in}^2\text{)}$$

C_1 , C_2 , L , B , C_b are as defined in 3-2-1/1.1.

1.1.2(d) *Slamming Induced Bending Moment.* The slamming induced bending moment in kN-m (Ltf-ft) can be determined by the following equation:

$$M_{s\ell} = C_3 \Delta (1 + n_{cg}) (L - \ell_s) \text{ kN-m (tf-m, Ltf-ft)}$$

where

$$C_3 = 1.25 \text{ (0.125, 0.125)}$$

$$\Delta = \text{full load displacement, in metric tons (long tons)}$$

$$\ell_s = \text{length of slam load, in m (ft)}$$

$$= A_R / B_{wl}$$

$$A_R = 0.697\Delta/d \text{ m}^2 \text{ (} 25\Delta/d \text{ ft}^2\text{)}$$

$$B_{wl} = \text{waterline breadth at the LCG, in m (ft)}$$

$$n_{cg} = \text{maximum vertical acceleration as defined in 3-2-2/1.1, but } (1 + n_{cg}) \text{ is not to be taken less than indicated in 3-2-1/Table 1.}$$

L is as defined in 3-2-1/1.1.1.

TABLE 1
Minimum Vertical Acceleration

Δ (metric tons, long tons)	Minimum Vertical Acceleration, $(n_{cg} + 1)$ (g)
180 (177)	3
400 (394)	2
≥ 1200 (1181)	1

Note: Intermediate values of n_{cg} are to be determined by interpolation.

1.1.2(e) *Section Modulus*. The required hull-girder section modulus for $0.4L$ amidships is to be obtained from the following equation:

$$SM = \frac{M_t CQ}{f_p} \text{ cm}^2\text{-m (in}^2\text{-ft)}$$

where

$$M_t = \text{maximum total bending moment. To be taken as the greatest of the following:}$$

$$= M_{swh} + M_{wh}$$

$$= -M_{sws} - M_{ws}$$

$$= M_{sl}$$

$$M_{swh} = \text{maximum still-water bending moment in the hogging condition, in kN-m (tf-m, Ltf-ft), as determined in 3-2-1/1.1.2(c).}$$

$$M_{sws} = \text{maximum still water bending moment in the sagging condition, in kN-m (tf-m, Ltf-ft), as determined in 3-2-1/1.1.2(c).}$$

$$M_{wh} = \text{maximum wave induced bending moment in the hogging condition, in kN-m (tf-m, Ltf-ft), as determined in 3-2-1/1.1.2(b).}$$

$$M_{ws} = \text{maximum wave induced bending moment in the sagging condition, in kN-m (tf-m, Ltf-ft), as determined in 3-2-1/1.1.2(b).}$$

$$M_{sl} = \text{maximum slamming induced bending moment, in kN-m (tf-m, Ltf-ft), as determined in 3-2-1/1.1.2(d).}$$

$$f_p = 17.5 \text{ kN/cm}^2, (1.784 \text{ tf/cm}^2, 11.33 \text{ Ltf/in}^2)$$

C and Q are as defined in 3-2-1/1.1.1.

Consideration may be given to a seakeeping analysis based on craft speed and sea state to determine M_{ws} and M_{wh} .

1.3 Extension of Midship Section Modulus

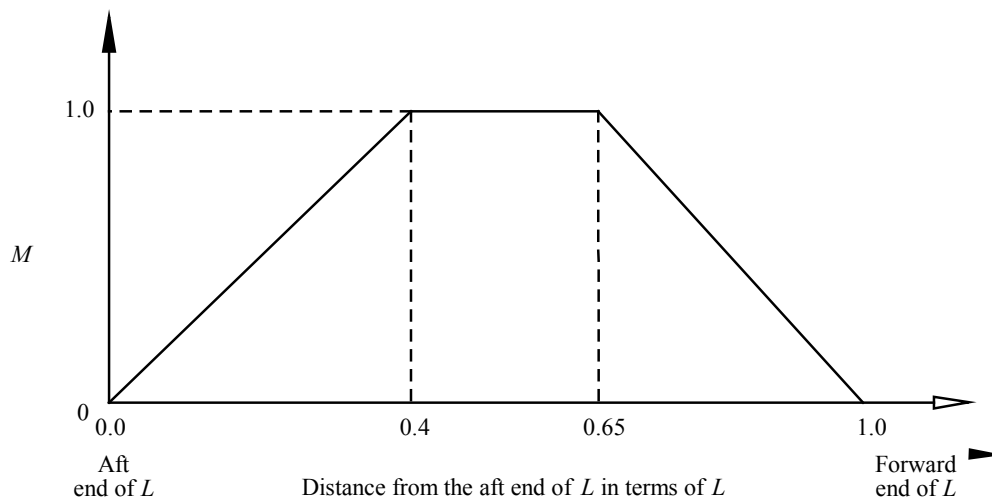
Where the still-water bending moment envelope is not submitted or where 3-2-1/1.1.1 governs, the scantlings of all continuous and all effectively developed longitudinal material are to be maintained throughout $0.4L$ amidships and may be gradually tapered beyond. The area of the strength deck and other effective decks comprising of plating and longitudinal members may be reduced linearly from $0.4L$ amidships to the ends. The ends of all continuous and effectively developed longitudinal members are to terminate with back-up brackets extending to and attached to an adjacent transverse member. The bracket is to extend for a distance not less than the depth of the member.

Structure that is not continuous throughout the midships $0.4L$ and beyond, but is effectively developed by brackets and welding to provide continuity of area, may be taken to contribute to the hull girder section modulus, provided the buckling strength required by 3-2-4/1.5 is maintained in way of the brackets.

Where the scantlings are based on the envelope curve of still-water bending moments, items included in the hull-girder section modulus amidships are to be extended as necessary to meet the hull-girder section modulus required at the location being considered, taking into account the distance required for the member to become fully effective (See 3-2-1/1.7.2).

The envelope curve of M_{ws} and M_{wh} may be obtained by multiplying the midship value by the distribution factor M in 3-2-1/Figure 2.

FIGURE 2
Distribution Factor M



1.5 Moment of Inertia

The hull-girder moment of inertia, I , at amidships is to be not less than given by the following equation:

$$I = \frac{L}{QC} \frac{SM}{K} \text{ cm}^2\text{-m}^2 \text{ (in}^2\text{-ft}^2\text{)}$$

where

SM = required hull-girder section modulus in 3-2-1/1.1.1 or 3-2-1/1.1.2, whichever is greater, in $\text{cm}^2\text{-m}$ ($\text{in}^2\text{-ft}$)

K = factor dependent on the material and craft length as given in 3-2-1/Table 2 below

L , C and Q are as defined in 3-2-1/1.1.1.

TABLE 2
Factor, K

L (m, ft)	Steel	Aluminum	FRP (Basic Laminate)
Restricted Service $L < 61$ m (200 ft)	50	13.33	1.8
Unrestricted Service $L \leq 61$ m (200 ft)	40	13.33	1.8
All Craft $L > 61$ m (200 ft)	33.3	11.1	1.5

Note: For fiber reinforced plastic laminates that are greater than the ABS basic laminate (as defined in Part 2, Section 6) the value for K can be adjusted by the ratio of E_o/E_b where:

E_o = the elastic modulus of the actual hull laminate in N/mm²
 (kgf/mm², psi)

E_b = 6890 N/mm² (703 kgf/mm², 1,000,000 psi)

1.7 Section Modulus and Moment of Inertia Calculation

1.7.1 Items Included in the Calculation

In general, the following items may be included in the calculation of the section modulus and moment of inertia provided they are continuous or effectively developed within midship $0.4L$, have adequate buckling strength, and are gradually tapered beyond the midship $0.4L$.

- Deck plating (strength deck and other effective decks)
- Shell and inner bottom plating
- Deck and bottom girders
- Plating and longitudinal stiffeners of longitudinal bulkheads
- All longitudinals of deck, sides, bottom, and inner bottom. See also 3-2-5/1.1.1

1.7.2 Effective Areas Included in the Calculation

In general, the net sectional areas of longitudinal strength members are to be used in the hull girder section modulus calculations, except that small isolated openings need not be deducted provided the openings and the shadow area breadths of other openings in any one transverse section do not reduce the section modulus by more than 3%. The breadth or depth of such openings is not to be greater than 25% of the breadth or depth of the member in which it is located with a maximum of 75 mm (3 in.) for scallops. The shadow area of an opening is the area forward and aft of the opening enclosed by the lines tangential to the corners of the opening intersecting each other to form an included angle of 30 degrees.

1.7.3 Section Modulus to the Deck or Bottom

The section modulus to the deck or bottom is obtained by dividing the moment of inertia by the distance from the neutral axis to the molded deck at side amidships or baseline, respectively. Where a long deckhouse or superstructure is considered as part of the hull girder, the section modulus to the deck is obtained by dividing the moment of inertia by the distance from the neutral axis to the top of the bulwark, deckhouse or superstructure.

1.7.4 Breaks

Craft having partial superstructures are to be specially strengthened in way of breaks to limit the local increase in stresses at these locations. The main deck plate and side shell plate thickness is to be increased a minimum of 25%, but the increase need not exceed 6.5 mm (0.25 in.). This increase is to extend well beyond the break in both directions in such a fashion to provide a long gradual taper. Where breaks of the superstructure (e.g., long forecastle) are appreciably beyond the amidships $0.5L$, these requirements may be modified. Gangways, large freeing ports and other openings in the shell or bulwarks are to be kept well clear of breaks, and any holes which must be unavoidably be cut in the plating are to be kept as small as possible and are to be circular or oval in form.

1.9 Hull Girder Shear Strength Calculation – For Craft 61 m (200 ft) in Length and Over

1.9.1 General

The nominal total shear stresses due to still-water and wave-induced loads are to be based on the maximum algebraic sum of the shear force in still-water, F_{sw} , the wave-induced shear force, F_w , and the slam induced shear force, F_{sb} , at the location being considered. The thickness of the side shell is to be such that the nominal total shear stress as obtained by 3-2-1/1.9.3 are not greater than $11.0/Q$ kN/cm² ($1.122/Q$ tf/cm², $7.122/Q$ Ltf/in²) where Q is as defined in 3-2-1/1.1.1. Consideration is also to be given to the shear buckling strength of the side shell plating.

1.9.2 Wave Shear Forces

The envelopes of maximum shearing forces induced by waves, F_w , as shown in 3-2-1/Figures 3 and 4 may be obtained from the following equations:

$$F_{wp} = +kF_1C_1LB(C_b + 0.7) \times 10^{-2} \quad \text{For positive shear force}$$

$$F_{wn} = -kF_2C_1LB(C_b + 0.7) \times 10^{-2} \quad \text{For negative shear force}$$

where

- F_{wp}, F_{wn} = maximum shearing force induced by wave, in kN (tf, Ltf)
- k = 30 (3.059, 0.2797)
- F_1 = distribution factor as shown in 3-2-1/Figure 3
- F_2 = distribution factor as shown in 3-2-1/Figure 4

C_1, L, B and C_b are as defined in 3-2-1/1.1.1.

FIGURE 3
Distribution Factor F_1

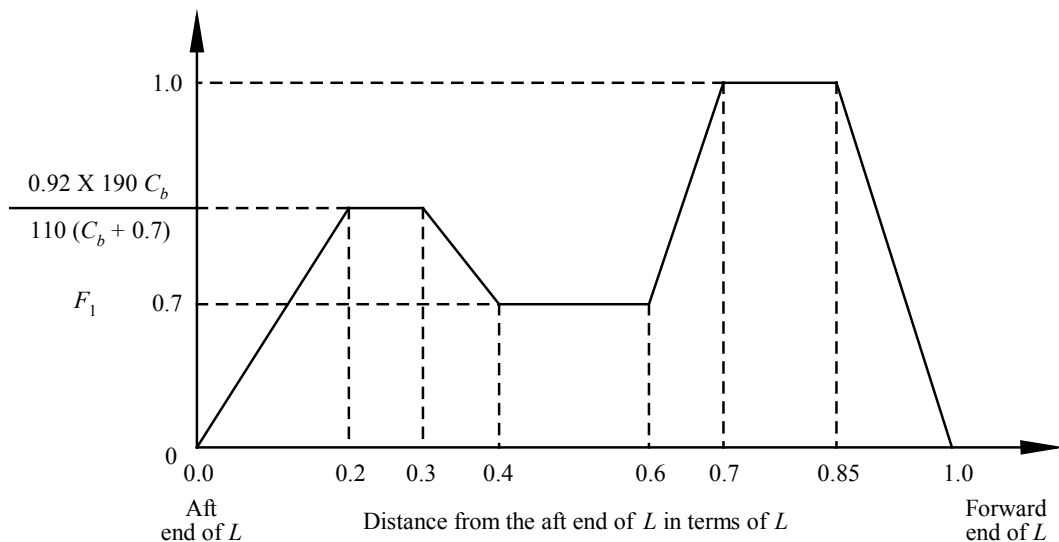
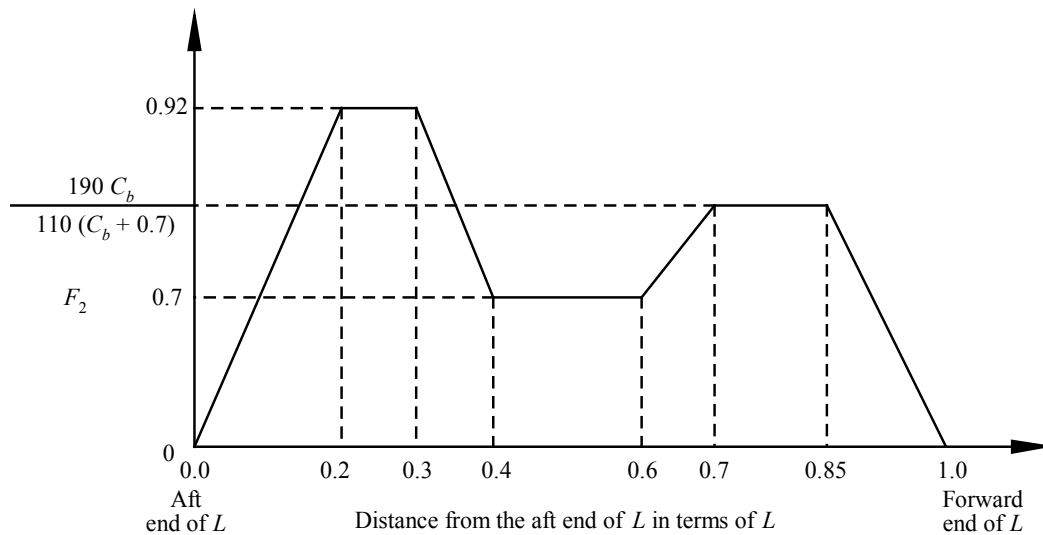


FIGURE 4
Distribution Factor F_2



1.9.3 Slam Induced Shear Force

The slamming induced shear force can be determined by the following equation:

$$F_{sl} = C_4 F_1 \Delta (n_{cg} + 1) \text{ kN (tf, Ltf)} \quad \text{for positive shear force}$$

$$F_{sl} = C_4 F_2 \Delta (n_{cg} + 1) \text{ kN (tf, Ltf)} \quad \text{for negative shear force}$$

where

$$C_4 = 4.9 (0.5)$$

$$\Delta = \text{full load displacement in metric tons (long tons)}$$

$$n_{cg} = \text{maximum vertical acceleration as defined in 3-2-2/1.1}$$

1.9.4 Shear Strength

For craft without continuous longitudinal bulkheads, the nominal total shear stress f_s in the side shell plating may be obtained from the greater of the following equations:

$$f_s = (F_{sw} + F_w) m / 2t_s I$$

$$f_s = F_{sl} m / 2t_s I$$

where

$$f_s = \text{nominal total shear stress, in kN/cm}^2 \text{ (tf/cm}^2, \text{ Ltf/in}^2\text{)}$$

$$I = \text{moment of inertia of the hull girder section, in cm}^4 \text{ (in}^4\text{), at the section under consideration}$$

$$m = \text{first moment about the neutral axis, of the area of the effective longitudinal material between the horizontal level at which the shear stress is being determined and the vertical extremity of effective longitudinal material, taken at the section under consideration, in cm}^3 \text{ (in}^3\text{)}$$

$$t_s = \text{thickness of the side shell plating, at the position under consideration, in cm (in.)}$$

$$F_{sw} = \text{hull-girder shearing force in still-water, in kN (tf, Ltf)}$$

$$F_w = F_{wp} \text{ or } F_{wm} \text{ as specified by 3-2-1/1.9.2, depending upon loading}$$

$$F_{sl} = \text{slam induced shear force, in kN (Ltf), as indicated in 3-2-1/1.9.3. The slam induced shear force is to be applied in both the hogging and sagging conditions}$$

1.9.5 Shearing Strength for Craft with Two or Three Longitudinal Bulkheads

For craft having continuous longitudinal bulkheads the total shear stresses in the side shell and longitudinal bulkhead plating are to be calculated by an acceptable method. In determining the still-water shear force, consideration is to be given to the effect of non-uniform athwartship distribution of loads. The methods described in Appendix 3-2-A1 of the *ABS Rules for Building and Classing Steel Vessels* may be used as a guide in calculating the nominal total shear stress f_s related to the shear flow in the side shell or longitudinal bulkhead plating. Alternative methods of calculation will also be considered. One acceptable method is shown in Appendix 5C-2-A1 of the *ABS Rules for Building and Classing Steel Vessels*.

1.9.6 Hull Girder Shear Strength – FRP Craft

Hull girder shear strength will be specially considered on fiber reinforced plastic craft over 24 m (79 ft) in length.

1.9.7 Craft of Unusual Proportion

Craft having unusual proportions will be specially considered.

1.11 Hull Girder Torsional Loads

Torsional calculations may be required for craft with large deck openings. Racking load calculations may be required for craft with tall superstructures.

3 Primary Hull Strength – Twin-Hulled Craft

3.1 Longitudinal Hull Girder Strength

The following applies to catamarans, surface effect craft, and similar configuration twin hulled craft.

The longitudinal strength requirements for twin-hulled craft are as given in 3-2-1/1.1, with the following modifications:

- i) B is to be taken as the sum of the waterline breadths of each hull.
- ii) For craft less than 61 m (200 ft), longitudinal shear strength need not be considered unless they have unusual or highly concentrated loads. For craft over 61 m (200 ft) the shear strength will be specially considered.
- iii) Items as listed in 3-2-1/1.7 may be included in the longitudinal strength calculation for the total cross section of the hulls, with the addition of the cross deck bridging structure. Consideration is to be given to the length over which the cross-deck structure becomes fully effective.

3.3 Catamaran Transverse Loadings

The transverse primary hull loadings are determined by the following equations:

$$M_{tb} = K_1 \Delta B_{cl} (1 + n_{cg}) \quad \text{kN-m (kgf-m, ft-lbs)}$$

$$M_{tt} = K_2 \Delta L (1 + n_{cg}) \quad \text{kN-m (kgf-m, ft-lbs)}$$

$$Q_t = K_1 \Delta (1 + n_{cg}) \quad \text{kN (kgf, lbs)}$$

where

- M_{tb} = design transverse bending moment acting upon the cross structure connecting the hulls
- M_{tt} = design torsional moment acting upon the transverse structure connecting the hulls
- Q_t = design vertical shear force acting upon the transverse structure connecting the hulls
- K_1 = 2.5 (0.255, 0.255)
- K_2 = 1.25 (0.1275, 0.1275)
- Δ = craft displacement in tonnes (kg, lbs).

- B_{cl} = distance between the hull centerlines, in meters (feet)
- L = length of craft, in meters (feet), as defined in 3-1-1/3.
- n_{cg} = vertical acceleration at the craft's center of gravity, see 3-2-2/1.1, but $(1 + n_{cg})$ is not to be taken less than indicated in 3-2-1/Table 1.

3.5 Transverse Strength for Catamarans and Surface Effect Craft

3.5.1 Direct Analysis

The design loads that are to be applied to the structure are the transverse bending moment, M_{tb} , the torsional moment, M_{tr} , and vertical shear force, Q_v , as defined in 3-2-1/3.3 and the longitudinal bending moments as given in 3-2-1/1.1.2. The requirements for the direct analysis are given in Section 3-1-3.

3.5.2 Analysis for Simple Structures

Guidance for the analysis of cross deck structures that are symmetrical forward and aft of a transverse axis at amidships can be found in Appendix 3-2-A2.

3.5.3 Design Stresses and Deflections

Regardless of the method of analysis used, the design stresses are as follows:

- σ_a = design transverse bending stress, $0.66\sigma_y$ for aluminum and steel craft and $0.33\sigma_u$ for FRP craft, in N/mm^2 (kgf/mm², psi)
- σ_{ab} = design torsional or combined stress, $0.75\sigma_y$ for aluminum and steel craft and $0.367\sigma_u$ for FRP craft, in N/mm^2 (kgf/mm², psi)
- τ_a = design transverse shear stress, $0.38\sigma_y$ for aluminum and steel craft and $0.40\tau_u$ for FRP craft, in N/mm^2 (kgf/mm², psi)
- σ_y = minimum yield strength of the material, in N/mm^2 (kgf/mm², psi). For aluminum the yield strength is to be for the unwelded condition and not to be greater than $0.7\sigma_{uw}$
- σ_u = minimum tensile or compressive strength, whichever is less, in N/mm^2 (kgf/mm², psi)
- σ_{uw} = ultimate tensile strength of material in the welded condition, in N/mm^2 (kgf/mm², psi)
- δ_m = maximum deflection for FRP craft, $(\sigma_d/E)L_I$, in m (in.)
- τ_u = minimum ultimate through thickness shear strength, in N/mm^2 (kgf/mm², psi)
- L_I = mean span of cross structure, in cm (in.), as indicated in 3-2-A2/Figure 2
- E = tensile or compressive modulus of the FRP laminate, whichever is lesser, in N/mm^2 (kgf/mm², psi)

3.7 Items Included in Transverse Moment of Inertia and Section Modulus Calculation

The following items may be included in the calculation of the transverse section modulus and moment of inertia provided that are continuous or effectively developed over the entire breadth of the cross structure or wet deck, and have adequate buckling strength:

- Deck plating, main deck and bottom plating of wet deck
- Transverse stiffeners on wet deck
- Transverse bulkheads or web frames which span the wet deck, and are effectively developed into the hulls
- Transverse box beams, that are effectively developed into the hulls
- Continuous transom plating and attached horizontal stiffeners

In general, the effective sectional area of the deck for use in calculating the section modulus is to exclude hatchways and other large openings in the deck.

Superstructures and house tops are generally not to be included in the calculation of sectional properties of the cross structure. Craft having unusual configuration such as cross-deck structure out-of-line with the main hull structure will be specially considered.

3.9 Craft with More Than Two Hulls

Transverse and torsional strength of craft with more than two hulls will be specially considered.

3.11 Hull Girder Torsional Loads

Torsional calculations may be required for craft with large deck openings. Racking load calculations may be required for craft with high superstructures.

5 Strength Considerations for Hydrofoil Borne Craft

5.1 Longitudinal Strength

The hull weight curve showing full load, lightship and partial load (if more severe) is to be submitted. The support reactions for each of the hydrofoils are to be shown. The resulting shear and bending moment diagrams, as derived from these curves, are to be submitted for approval.

Hull deflection under the condition of maximum bending moment is not to exceed 1/200 of the distance between the forward and aft foil attachment points.

5.3 Calculation of Loads from Hydrofoil Appendages

The maximum forces transmitted by any hydrofoil to the craft structure is given by the following equations:

$$F_L = C_U C_L V^2 A_P$$

$$F_D = C_U V^2 (C_{DF} A_{FF} + C_{DS} A_{FS}) + (\text{Wetted surface drag})$$

where

F_L = maximum lift force on craft exerted by hydrofoil, in kgf (lbs). This force is assumed to act perpendicular to the plane of the foil.

F_D = maximum drag force on craft exerted by hydrofoil plus strut, in kgf (lbs). This force is assumed to act directly aft from the center of the foil.

C_U = 13.847 (2.835)

C_L = peak coefficient of lift for the foil selected.

C_{DF} = peak coefficient of drag for the foil selected.

C_{DS} = peak coefficient of drag for the strut section selected.

V = maximum craft speed, in knots.

A_P = plan view area of foil, in m² (ft²)

A_{FF} = frontal area of foil, in m² (ft²)

A_{FS} = frontal area of strut, in m² (ft²)

Total drag of the foil and strut (or similar appendage) is given by the drag term F_D that includes the frictional drag coefficient, as a function of wetted surface and Reynolds number.

The strength of the foils and struts are to be based on F_L and F_D and the resulting bending moments, shear forces, and vertical forces. The strength of the connections of the struts to the hull is to be based on the bending moments, shear forces, and vertical forces applied through the struts. A factor of safety on the yield strength of the material (aluminum use the as-welded condition) is to be not less than 2.0. Calculations of the bending moment, shear forces, and stiffness, are to be carried out and submitted by the designer.

Additionally, calculations supporting the “Fail-Safe” performance of each foil attachment structure are to be submitted.

Watertight integrity of the shell is to be maintained in the event of a collision of the hydrofoil appendages with a solid object in the water. A design safety factor of 2.0 on the yield strength or 3.0 on the ultimate strength of the foil strut bearing is to be used to assess the strength of the foil for the collision condition.

7 Effective Decks

To be considered effective for use in calculating the hull girder section modulus, the thickness of the deck plating is to comply with the requirements of Section 3-2-3. The deck areas are to be maintained throughout the midship $0.4L$ and may be gradually reduced to one half their midship value at $0.15L$ from the ends. Only that portion of deck which is continuous through the transverse structure may be considered effective.

9 Operating Manual

Craft are to be furnished with an operating manual providing guidance on:

- i) Means of identifying that the Manual is for the subject craft including principle particulars of the vessel.
- ii) Loading conditions on which the design of the craft has been based, including cargo loading on decks, loading ramps, and double bottoms.
- iii) There should also be evidence of approved loading and stability conditions on board the craft. These should preferably be included in the operating manual. If they are a separate document, they should be referenced in the operating Manual.
- iv) Maximum approved speed and associated displacement.
- v) Service Limitations, any scope of operations and/or operational limits as applicable such as distance from port of refuge.
- vi) Maximum operational speeds for the various sea-states (significant wave heights) in which the craft is intended to operate, in conjunction with the **OE** notation (see 1-1-1/7).
- vii) Permissible limits of still-water bending moments and shear forces, for craft 61m (200 ft) in length or greater.
- viii) Position and application of watertight and weathertight (doors, hatches etc.) closing appliances necessary to meet the Load Line assignment; identification of doors and hatches to be kept closed at sea; information on storm shutters and their use; location of emergency escapes.
- ix) From the aspect of the Flag Administration, depending on the Administration to which the craft is flagged, there will also be a need for other items to be included such as safety plan, fire fighting procedures, means of escape, evacuation procedures, operation of life saving appliances, and requirements for safe operation of the vessel.

CHAPTER 2 Hull Structures and Arrangements

SECTION 2 Design Pressures

1 Monohulls

The bottom and side pressures are to be checked using the displacement (Δ), speed (V), draft (d), and running trim (τ) in the full load, half load, and light load conditions. If the craft is receiving a freeboard assignment, the parameters used in the full load condition are to coincide with the assigned freeboard. If the craft is not receiving a freeboard assignment, the parameters used in the full load condition are to correspond to the condition of the craft with the maximum operating deadweight. The parameters used in the half load condition are to correspond to the condition of the craft with 50% of the maximum operating deadweight, and the parameters used in the light load condition are to correspond to the condition of the craft with 10% of the maximum operating deadweight plus the maximum speed of the craft.

1.1 Bottom Design Pressure

The bottom design pressure is to be the greater of those, as given in the following equations, for the location under consideration. Bottom structure design pressures are dependent upon the service in which the craft operates. The bottom design pressure applies to hull bottoms below the chines or the upper turn of the bilge.

1.1.1 Bottom Slamming Pressure

$$p_{bcg} = \frac{N_1 \Delta}{L_w B_w} [1 + n_{cg}] F_D \quad \text{kN/m}^2 \text{ (tf/m}^2, \text{ psi)}$$

$$p_{bxx} = \frac{N_1 \Delta}{L_w B_w} [1 + n_{xx}] \left[\frac{70 - \beta_{bx}}{70 - \beta_{cg}} \right] F_D \quad \text{kN/m}^2 \text{ (tf/m}^2, \text{ psi)}$$

1.1.2 Bottom Slamming for Craft Less Than 61 meters (200 feet)

The design pressure may be:

$$p_{bxx} = \frac{N_1 \Delta}{L_w B_w} [1 + n_{cg}] F_D F_V \quad \text{kN/m}^2 \text{ (tf/m}^2, \text{ psi)}$$

1.1.3 Hydrostatic Pressure

$$p_d = N_3 (0.64H + d) \quad \text{kN/m}^2 \text{ (tf/m}^2, \text{ psi)}$$

where

$$p_{bcg} = \text{bottom design pressure at LCG, kN/m}^2 \text{ (tf/m}^2, \text{ psi)}$$

$$p_{bxx} = \text{bottom design pressure at any section clear of LCG, kN/m}^2 \text{ (tf/m}^2, \text{ psi)}$$

$$p_d = \text{bottom design pressure based on hydrostatic forces, kN/m}^2 \text{ (tf/m}^2, \text{ psi)}$$

n_{cg} = the vertical acceleration of the craft as determined by a model test, theoretical computation, or service experience (see Section 3-1-3). If this information is not readily available during the early stages of design, the following formula utilizing the average 1/100 highest vertical accelerations at LCG can be used:

$$n_{cg} = N_2 \left[\frac{12h_{1/3}}{B_w} + 1.0 \right] \tau [50 - \beta_{cg}] \frac{V^2 (B_w)^2}{\Delta} \text{ g's}$$

note that g's are the dimensionless ratio of the acceleration at sea level (9.8m/s², 32.2 ft/s²).

The vertical acceleration, n_{cg} , is typically not to be taken greater than the following:

$$n_{cg} = 1.39 + k_n \frac{V}{\sqrt{L}}$$

for speeds greater than $18\sqrt{L}$ ($9.94\sqrt{L}$) the maximum n_{cg} is 6.0 g (7.0 g for search and rescue type craft). The vertical accelerations are typically not to be taken less than 1.0 g for craft lengths less than 24 m (79 ft) and 2.0 g for craft lengths less than 12 m (39 ft). Intermediate values can be determined by interpolation. The vertical acceleration will need to be specially considered for craft fitted with seat belts or special shock mitigation seats.

k_n = 0.256 (0.463)

n_{xx} = average of the 1/100 highest vertical accelerations, at any section clear of LCG, in g's. Can be determined by the following equation:

$$= n_{cg} K_v$$

N_1 = 0.1 (0.01, 0.069)

N_2 = 0.0078 (0.0078, 0.0016)

N_3 = 9.8 (1.0, 0.44)

Δ = displacement at design waterline, in kg (lbs), see 3-2-2/1

L_w = craft length on the waterline with the craft at the design displacement and in the displacement mode, in m (ft)

B_w = maximum waterline beam, in m (ft)

H = wave parameter, $0.0172L + 3.653$ m ($0.0172L + 11.98$ ft), generally not to be taken less than the maximum survival wave height for the craft

$h_{1/3}$ = significant wave height, m (ft), see 3-2-2/Table 1

τ = running trim at V , in degrees, but generally not to be taken less than 4° for craft $L < 50$ m (165 ft), nor less than 3° for $L > 50$ m (165 ft). Special consideration will be given to designers values predicted from model tests.

β_{cg} = deadrise at LCG, degrees, generally not to be taken less than 10° nor more than 30°.

β_{bx} = deadrise at any section clear of LCG, in degrees, not to be taken less than 10° nor greater than 30°, see 3-2-2/Figure 1.

V = craft design speed in knots, see 3-2-2/Table 1

F_D = design area factor given in 3-2-2/Figure 3 for given values of A_D and A_R . Generally not to be taken less than 0.4. See 3-2-2/Table 2 for minimum values of F_D for craft less than 24 m (79 ft) in length.

- F_V = vertical acceleration distribution factor given in 3-2-2/Figure 5.
- K_V = vertical acceleration distribution factor given in 3-2-2/Figure 4.
- A_D = design area, cm² (in²). For plating it is the actual area of the shell plate panel but not to be taken as more than $2.5s^2$. For longitudinals, stiffeners, transverses and girders it is the shell area supported by the longitudinal stiffener, transverse or girder; for transverses and girders the area used need not be taken less than $0.33\ell^2$.
- A_R = reference area, cm² (in²), $6.95\Delta/d$ cm² ($1.61\Delta/d$ in²).
- s = spacing of longitudinals or stiffeners, in cm (in.)
- ℓ = unsupported span of internals, in cm (in.). See 3-2-4/1.3.1.
- d = stationary draft, in m (ft), vertical distance from outer surface of shell measured at centerline to design waterline at middle of design waterline length, but generally not to be taken as less than $0.04L$. See 3-2-2/1.

TABLE 1
Design Significant Wave Heights, $h_{1/3}$, and Speeds, V

	Operational Condition	
	$h_{1/3}$	V
High Speed Craft	4 m (13 ft)	$V_m^{(2)}$
Coastal Craft	2.5 m (8.5 ft)	$V_m^{(2)}$
Riverine Craft	0.5 m (1.75 ft)	$V_m^{(2)}$

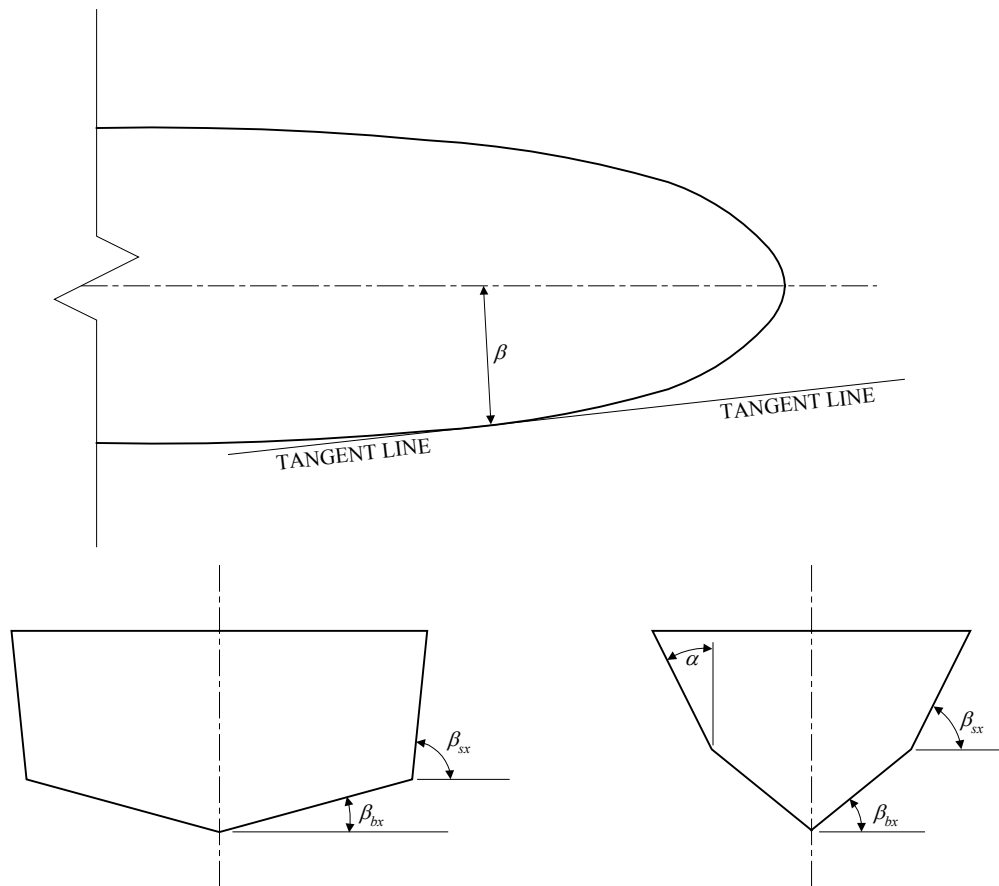
Notes:

- 1 Not to be taken less than $L/12$
- 2 V_m = maximum speed for the craft in the design condition specified in 3-2-2/1

TABLE 2
Minimum Values for F_D ($L \leq 24$ m, 79 ft)

s mm (in.)	F_D
250 (9.75)	0.85
500 (16.75)	0.75
750 (29.5)	0.60
1000 (39.25)	0.50
1250 (49.25)	0.40

FIGURE 1
Deadrise, Flare, and Entry Angles



1.3 Side and Transom Structure, Design Pressure

The side design pressure, p_s , is to be not less than given by the equations:

1.3.1 Slamming Pressure

$$p_{sxx} = \frac{N_1 \Delta}{L_w B_w} [1 + n_{xx}] \left[\frac{70 - \beta_{sx}}{70 - \beta_{cg}} \right] F_D \quad \text{kN/m}^2 \text{ (tf/m}^2, \text{ psi)}$$

1.3.2 Hydrostatic Pressure

$$p_s = N_3 (H_s - y) \quad \text{kN/m}^2 \text{ (tf/m}^2, \text{ psi)}$$

1.3.3 Fore End

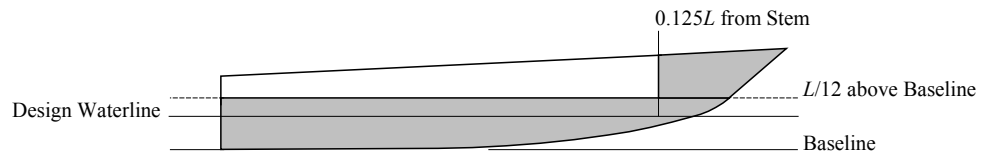
$$p_{sf} = 0.28 F_a C_F N_3 (0.22 + 0.15 \tan \alpha) (0.4 V \sin \beta + 0.6 \sqrt{L})^2 \quad \text{kN/m}^2 \text{ (tf/m}^2)$$

$$p_{sf} = 0.92 F_a C_F N_3 (0.22 + 0.15 \tan \alpha) (0.4 V \sin \beta + 0.33 \sqrt{L})^2 \quad \text{psi}$$

where L is generally not to be taken less than 30 m (98 ft)

where

p_{sxx} = side design slamming pressure at any section clear of LCG, in kN/m^2 (tf/m^2 , psi). For craft greater than 24 m (79 ft) in length, the side design slamming pressure applies both along the entire length below $L/12$ above baseline and to the region forward of $0.125L$



p_s = side design pressure due to hydrostatic forces, in kN/m^2 (tf/m^2 , psi), but is not to be taken less than the following:
 = $0.05N_3L$ kN/m^2 (tf/m^2 , psi) at or below $L/15$ above the base line or any height above base line forward of $0.125L$ from the stem
 = $0.033N_3L$ kN/m^2 (tf/m^2 , psi) above $L/15$ above the base line, aft of $0.125L$ from the stem

P_{sf} = side design pressure for forward of $0.125L$ from the stem.

H_s = $0.083L + d$ in meters (feet), but it is not to be taken less than $D + 1.22$ ($D + 4$) for craft less than 30 m (100 ft)
 = $0.64H + d$ in meters (feet) for craft over 30 m (100 ft); where H is defined in 3-2-2/1.1

y = distance above base line of location being considered, in m (ft)

L = craft length as defined in 3-1-1/3

β_{sx} = deadrise of side at any section clear of LCG, in degrees, not to be taken greater than 55° , see 3-2-2/Figure 1

C_F = $0.0125L$ for $L < 80$ m ($0.00381L$ for $L < 262$ ft)
 = 1.0 for $L \geq 80$ m (262 ft)

F_a = 3.25 for plating and 1.0 for longitudinals, transverses and girders

α = flare angle, the angle between a vertical line and the tangent to the side shell plating, measured in a vertical plane at 90° to the horizontal tangent to the side shell, see 3-2-2/Figure 1.

β = entry angle, the angle between a longitudinal line, parallel to the centerline and the horizontal tangent to the side shell, see 3-2-2/Figure 1.

N_1 , N_3 , Δ , L_w , B_w , V , n_{xx} , β_{cg} , H , d and F_D are as defined in 3-2-2/1.1.

3 Multi-Hull and Surface Effect Craft

The bottom and side pressures are to be checked using the displacement (Δ), speed (V), draft (d) and running trim (τ) in the full load, half load and lightship conditions. If the craft is receiving a freeboard assignment, the parameters used in the full load condition are to coincide with the approved freeboard assignment. If the craft is not receiving a freeboard assignment, the parameters used in the full load condition are to correspond to the maximum operating deadweight. The parameters used in the half load condition are to correspond to 50% of the maximum operating deadweight, and the parameters used in the lightship condition are to correspond to 10% of the maximum operating deadweight plus the maximum speed of the craft. The on-cushion speed is to be used for surface effect craft.

3.1 Bottom Design Pressure

The bottom design pressure is to be the greater of the following equations, for the location under consideration. Bottom design pressures are dependent upon the service in which the craft operates. The bottom design pressure applies to hull bottoms below the chines or the upper turn of the bilge for catamarans, trimarans or other multihulled craft and surface effect craft. Bottoms of twin hull surface effect craft shall be considered as catamaran hulls for the purpose of calculation of the bottom slamming pressure.

3.1.1 Bottom Slamming Pressure

$$p_{bcg} = \frac{N_1 \Delta}{L_w N_h B_w} [1 + n_{cg}] F_D \quad \text{kN/m}^2 \text{ (tf/m}^2 \text{, psi)}$$

$$p_{bxx} = \frac{N_1 \Delta}{L_w N_h B_w} [1 + n_{xx}] \left[\frac{70 - \beta_{bx}}{70 - \beta_{cg}} \right] F_D \quad \text{kN/m}^2 \text{ (tf/m}^2 \text{, psi)}$$

3.1.2 Bottom Slamming for Craft Less Than 61 meters (200 feet)

The design pressure may be:

$$p_{bxx} = \frac{N_1 \Delta}{L_w N_h B_w} [1 + n_{cg}] F_D F_V \quad \text{kN/m}^2 \text{ (tf/m}^2 \text{, psi)}$$

3.1.3 Hydrostatic Pressure

$$p_d = N_3 (0.64H + d) \quad \text{kN/m}^2 \text{ (tf/m}^2 \text{, psi)}$$

where

n_{cg} = the vertical acceleration of the craft as determined by a model test, theoretical computation, or service experience (see Section 3-1-3). If this information is not readily available during the early stages of design, the following formula utilizing the average 1/100 height vertical accelerations at LCG can be used:

$$n_{cg} = N_2 \left[\frac{12h_{1/3}}{N_h B_w} + 1.0 \right] \tau \left[50 - \beta_{cg} \right] \frac{V^2 (N_h B_w)^2}{\Delta} \quad \text{g's}$$

The maximum and minimum vertical accelerations defined in 3-2-2/1.1 are applicable to multihull craft.

B_w = maximum waterline beam of one hull, in m (ft)

N_h = number of hulls

p_{bcg} , p_{bxx} , N_1 , N_2 , N_3 , Δ , L_w , V , F_V , n_{xx} , β_{bx} , β_{cg} , H , d and F_D are as defined in 3-2-2/1.1.

3.3 Side and Transom Structure, Design Pressure

The side design pressure, p_s , is to be not less than given by the equations:

3.3.1 Slamming Pressure

$$p_{sxx} = \frac{N_1 \Delta}{L_w N_h B_w} [1 + n_{xx}] \left[\frac{70 - \beta_{sx}}{70 - \beta_{cg}} \right] F_D \quad \text{kN/m}^2 \text{ (tf/m}^2 \text{, psi)}$$

3.3.2 Hydrostatic Pressure

$$p_s = N_3 (H_s - y) \quad \text{kN/m}^2 \text{ (tf/m}^2 \text{, psi)}$$

3.3.3 Fore End

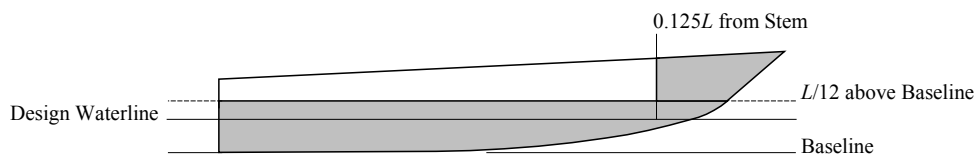
$$p_{sf} = 0.28 F_a C_F N_3 (0.22 + 0.15 \tan \alpha) (0.4V \sin \beta + 0.6 \sqrt{L})^2 \quad \text{kN/m}^2 \text{ (tf/m}^2 \text{)}$$

$$p_{sf} = 0.92 F_a C_F N_3 (0.22 + 0.15 \tan \alpha) (0.4V \sin \beta + 0.33 \sqrt{L})^2 \quad \text{psi}$$

where L is generally not to be taken less than 30 m (98 ft)

where

p_{sxx} = side design slamming pressure at any section clear of LCG, in kN/m^2 (tf/m^2 , psi). For craft greater than 24 m (79 ft) in length, the side design slamming pressure applies both along the entire length below $L/12$ above baseline and to the region forward of $0.125L$



p_s = side design pressure due to hydrostatic forces, in kN/m^2 (tf/m^2 , psi), but is not to be taken less than the following:

= $0.05N_3L$ kN/m^2 (tf/m^2 , psi) at or below $L/15$ above the base line or at any height above base line forward of $0.125L$ from the stem.

= $0.033N_3L$ kN/m^2 (tf/m^2 , psi) above $L/15$ above the base line, aft of $0.125L$ from the stem.

p_{sf} = side design pressure for forward of $0.125L$ from the stem.

y = distance above base line, m (ft), of location being considered.

L = craft length, as defined in 3-1-1/3

F_a = 3.25 for plating and 1.0 for longitudinals, transverses and girders

C_F = $0.0125L$ for $L < 80$ m ($0.00381L$ for $L < 262$ ft)

= 1.0 for $L \geq 80$ m (262 ft)

α = flare angle, the angle between a vertical line and the tangent to the side shell plating, measured in a vertical plane at 90° to the horizontal tangent to the side shell, see 3-2-2/Figure 1.

β = entry angle, the angle between a longitudinal line, parallel to the centerline and the horizontal tangent to the side shell, see 3-2-2/Figure 1.

N_1 , N_3 , A , L_w , V , n_{xx} , β_{cg} , H_s , d and F_D are as defined in 3-2-2/1.1, β_{sxx} is as defined in 3-2-2/1.3. N_h and B_w are as defined in 3-2-2/3.1.

3.5 Wet Deck or Cross Structure

The wet deck design pressure is to be determined by the following equations:

$$p_{wd} = 30N_1F_DF_I V V_I (1 - 0.85h_a/h_{1/3}) \quad \text{kN/m}^2 \text{ (tf/m}^2, \text{ psi)}$$

where

N_1 = 0.10 (0.010, 0.00442)

h_a = vertical distance, in m (ft), from lightest draft waterline to underside of wet deck, at design point in question. h_a is not to be greater than $1.176h_{1/3}$

F_I = wet deck pressure distribution factor as given in 3-2-2/Figure 6

V_I = relative impact velocity as given below:

$$= \frac{4h_{1/3}}{\sqrt{L}} + 1 \quad \text{m/s}$$

$$= \frac{7.24h_{1/3}}{\sqrt{L}} + 3.28 \quad \text{ft/s}$$

V , $h_{1/3}$ and F_D are as defined in 3-2-2/1.1.

5 Deck Design Pressures – All Craft

The design pressures, p_d , are to be as given in 3-2-2/Table 3, see 3-2-2/Figure 2.

7 Superstructures and Deckhouses – All Craft

The design pressures, p_d , are to be as given in 3-2-2/Table 4.

9 Bulkhead Structure, Design Pressure – All Craft

9.1 Tank Boundaries

The design pressure for tank boundaries, for both integral and non-integral tanks is to be not less than the following equations, whichever is greater:

$$p_t = N_3 h \quad \text{kN/m}^2 \text{ (tf/m}^2, \text{ psi)}$$

$$p_t = \rho g (1 + 0.5 n_{xx}) h_2 \quad \text{kN/m}^2 \text{ (tf/m}^2, \text{ psi)}$$

where

N_3 = as defined in 3-2-2/1.1

h = greatest of the following distances, in m (ft), from lower edge of plate panel or center of area supported by stiffener, to:

- 1) A point located above the top of the tank, at a distance of two-thirds the height from the top of the tank to the top of the overflow.
- 2) A point located at two-thirds of the distance to the main weather deck.
- 3) A point located above the top of the tank, not less than the greater of the following:
 - i) $0.01L + 0.15 \text{ m (} 0.01L + 0.5 \text{ ft)}$
 - ii) $0.46 \text{ m (} 1.5 \text{ ft)}$

where L is the craft length as defined in 3-1-1/3.

ρg = specific weight of the liquid, not to be taken less than $1.005 \text{ N/cm}^2\text{-m (} 0.1025 \text{ kgf/cm}^2\text{-m, } 0.44 \text{ lbf/in}^2\text{-ft)}$

n_{xx} = vertical acceleration at midspan of the tank, as defined in 3-2-2/1.1

h_2 = distance from lower edge of plate panel or center of area supported by stiffener to the top of the tank, in m (ft)

The heights of overflows are to be clearly indicated on the plans submitted for approval.

Pressurized tanks will be subject to special consideration.

9.3 Watertight Boundaries

The design pressure for watertight boundaries is to be not less than given by the following equation:

$$p_w = N_3 h \quad \text{kN/m}^2 \text{ (tf/m}^2, \text{ psi)}$$

where

N_3 = as defined in 3-2-2/1.1

h = distance, in m (ft), from the lower edge of plate panel or the center of area supported by the stiffener to the bulkhead deck at centerline

11 Operational Loads

Loads on the hull structure are dependent on the craft's mission, payload and operational environment. For classification purposes, the following payloads must be accounted for in addition to the other loads and pressures defined in this Section:

- i) Vehicle and human loads (see 3-2-3/1.9 and 3-2-4/1.15)
- ii) Take-off, landing, and stowage of helicopters

11.1 Human Loads

Composite deck structures are to withstand a point load equivalent to the weight of a man (90.7 kg, 200 lbf) in the middle of the plate or the midspan stiffener.

11.3 Helicopter Decks

11.3.1 General

Helicopter decks, where provided, are to meet the following structural and safety requirements.. See also 4-4-2/23.1.2 for Non-watertight spaces and 4-5-1/7.

Plans showing the arrangement, scantlings and details of the helicopter deck are to be submitted. The arrangement plan is to show the overall size of the helicopter deck and the designated landing area. If the arrangement provides for the securing of a helicopter or helicopters to the deck, the predetermined position(s) selected to accommodate the secured helicopter, in addition to the locations of deck fittings, for securing the helicopter are to be shown. The type of helicopter to be considered is to be specified and calculations for appropriate loading conditions are to be submitted.

11.3.2 Overall Distributed Loading

For a platform type helicopter decks, a minimum distributed loading of 2010 N/m² (205 kgf/m², 42 lbf/ft²) is to be taken over the entire helicopter deck. For all other helicopter decks, the minimum overall distributed load is to be as specified in 3-2-2/Table 3.

11.3.3 Helicopter Landing and Impact Loading

A load of not less than 75% of the helicopter maximum take-off weight is to be taken on each of two square areas, 0.3 m × 0.3 m (1 ft × 1 ft). Alternatively, the manufacturer's recommended wheel impact loading will be considered. The deck is to be considered for helicopter landings at any location within the designated landing area. The structural weight of the helicopter deck is to be added to the helicopter impact loading when considering girders, stanchions, truss supports, etc. Where the upper deck of a superstructure or deckhouse is used as a helicopter deck and the spaces below are normally manned (quarters, bridge, control room, etc) the impact loading is to be multiplied by a factor of 1.15.

11.3.4 Stowed Helicopter Loading

If provisions are made to accommodate helicopter secured to the deck in a predetermined position, the structure is to be considered for a local loading not to be taken less than:

$$P_{HC} = W_{to} (1 + 0.5n_{xx}) + C_e \quad \text{kN/m}^2 \text{ (tf/m}^2, \text{ psi)}$$

where

$$W_{to} = \text{maximum take-off weight}$$

$$n_{xx} = \text{same as 3-2-2/11.1.1}$$

$$C_e = 0.49 \text{ (0.05, 0.07)}$$

11.3.5 Special Landing Gear

Helicopters fitted with landing gear other than wheels will be specially considered.

11.3.6 Loading due to Motions of Craft

The structure supporting helicopter decks is to withstand the loads resulting from the motions of the craft.

11.3.7 Environmental Loading

Calculations are to consider anticipated wind and wave impact loadings on helicopter decks and their supporting structures.

TABLE 3
Deck Design Pressures, p_d

Location	kN/m^2	tf/m^2	psi
Exposed freeboard deck, and superstructure and deckhouse decks forward of $0.25L$.	$0.20L + 7.6$	$0.020L + 0.77$	$0.0088L + 1.10$
Freeboard deck inside enclosed superstructures and deckhouses, exposed superstructure and deckhouse decks aft of $0.25L$, and internal decks included in the hull girder bending moment	$0.10L + 6.1$	$0.010L + 0.62$	$0.0044L + 0.88$
Enclosed accommodations decks	5.0	0.5	0.71
Concentrated deck cargo loads, equipment foundations	$W(1 + 0.5n_{xx})$	$W(1 + 0.5n_{xx})$	$W(1 + 0.5n_{xx})$
Enclosed store rooms, machinery spaces, etc.	$\rho h(1 + 0.5n_{xx})$	$\rho h(1 + 0.5n_{xx})$	$(\rho/144)h(1 + 0.5n_{xx})$

Notes:

W = deck cargo load in kN/m^2 (tf/m^2 psi).

n_{xx} = average vertical acceleration at the location under consideration as defined in 3-2-2/1.1.

ρ = cargo density in kN/m^3 , tf/m^3 , lb/ft^3 , not to be taken less than 7.04 (0.715, 44.8)

h = height of enclosed store room, machinery space, etc., in m (ft)

L = craft length as defined in 3-1-1/3

- Where permanently attached equipment are fitted and the live load associated with this equipment is greater than the deck design pressure, the equipment live loads govern.

TABLE 4
Superstructures and Deckhouses Design Pressures

Location	$L = 12.2m (40 ft) \& less kN/m^2 (tf/m^2, psi)$	$L > 30.5m (100 ft) kN/m^2 (tf/m^2, psi)$
Superstructure and Deckhouse Front Plating	24.1 (2.46, 3.5)	37.9 (3.87, 5.50)
Superstructure and Deckhouse Front Stiffeners	24.1 (2.46, 3.5)	24.1 (2.46, 3.5)
Superstructure and Deckhouse Aft End and House Side Plating	10.3 (1.05, 1.5)	13.8 (1.41, 2.0)
Superstructure and Deckhouse Aft End and House Side Stiffeners	10.3 (1.05, 1.5)	10.3 (1.05, 1.5)
House Tops, Forward of Midships, Plating and Stiffeners	6.9 (0.7, 1.0)	8.6 (0.88, 1.25)
House Tops, Aft of Midships, Plating and Stiffeners	3.4 (0.35, 0.5)	6.9 (0.70, 1.0)

FIGURE 2
Decks, Superstructures, and Deckhouse Pressures

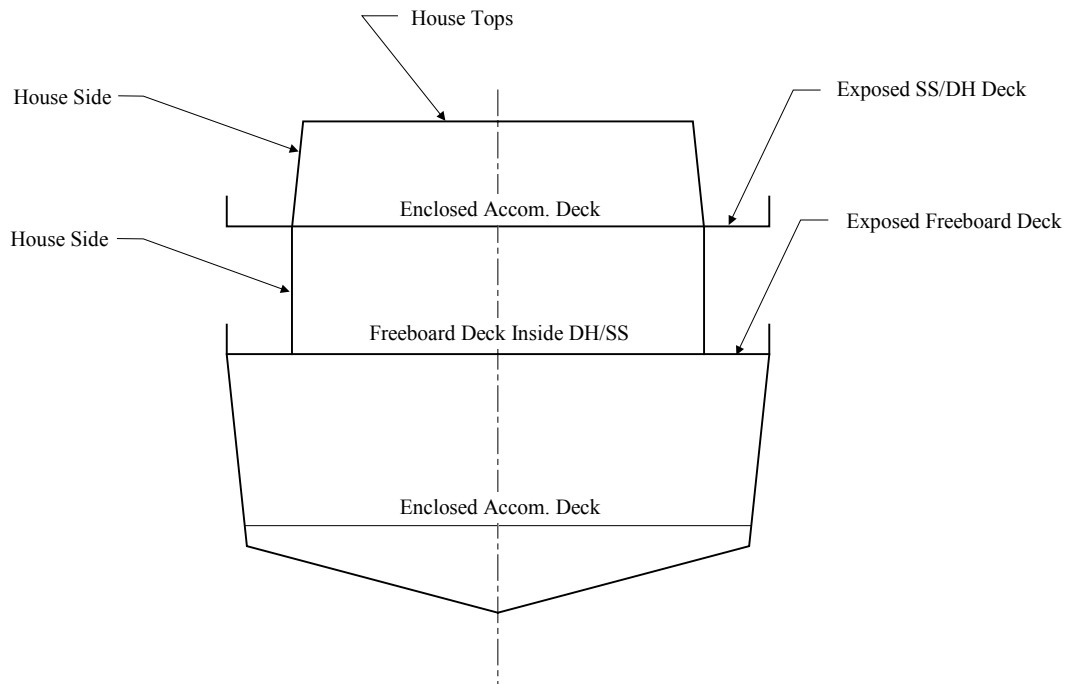


FIGURE 3
Design Area Factor F_D

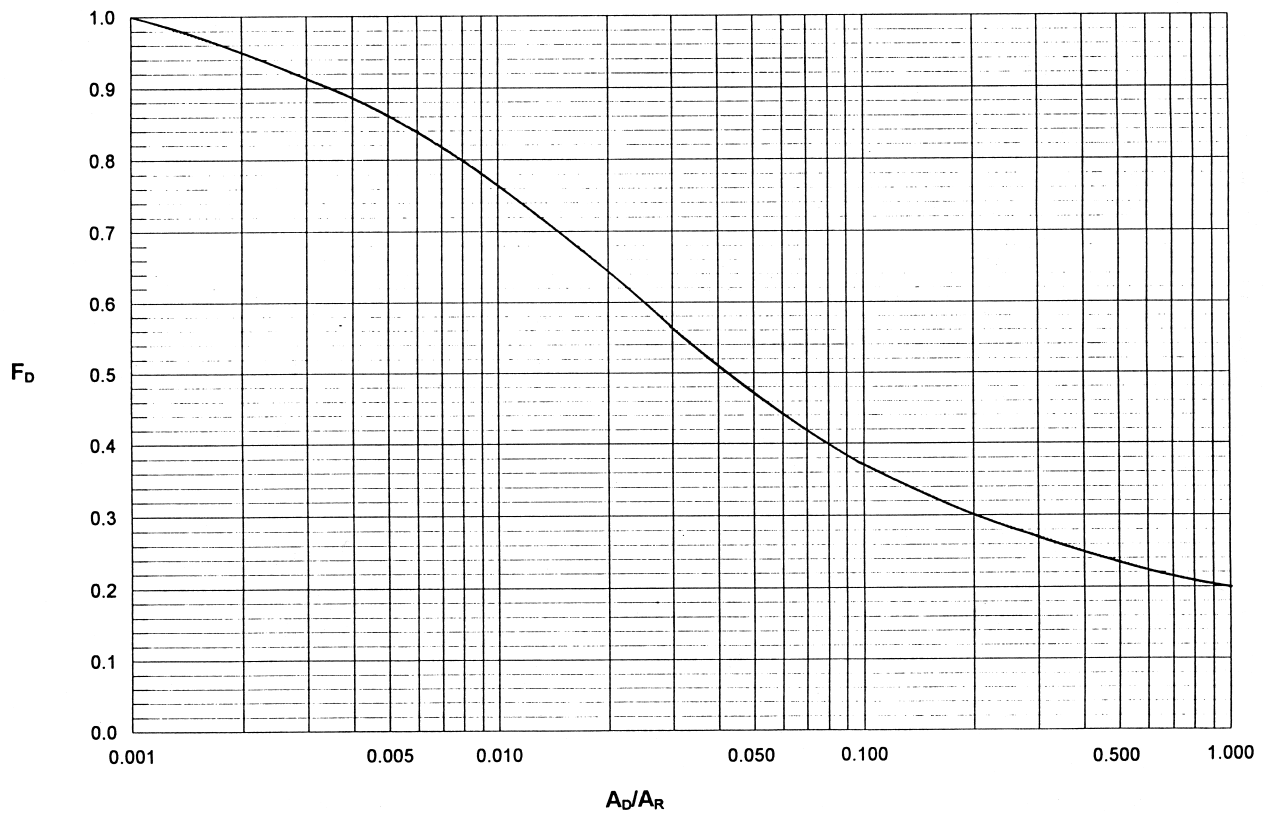


FIGURE 4
Vertical Acceleration Distribution Factor K_V

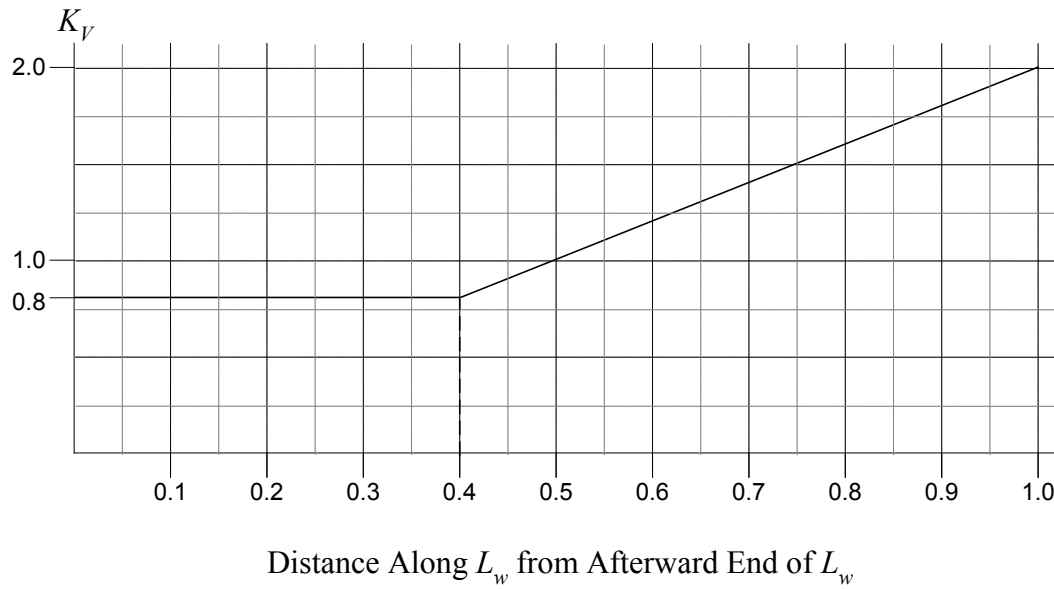


FIGURE 5
Vertical Acceleration Distribution Factor F_V

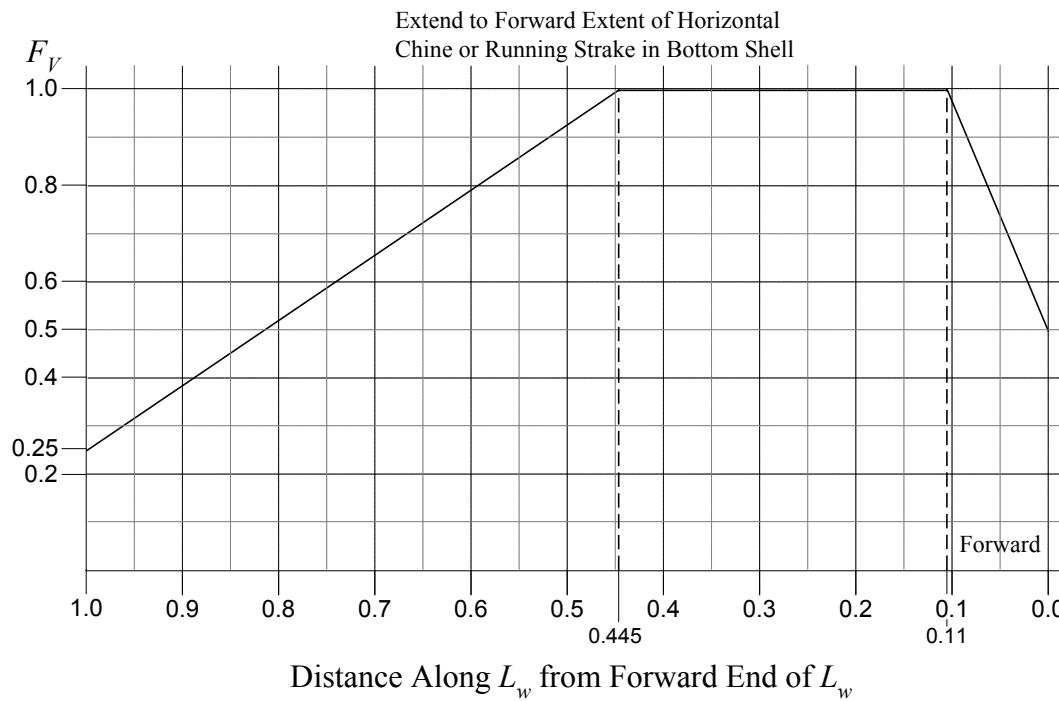
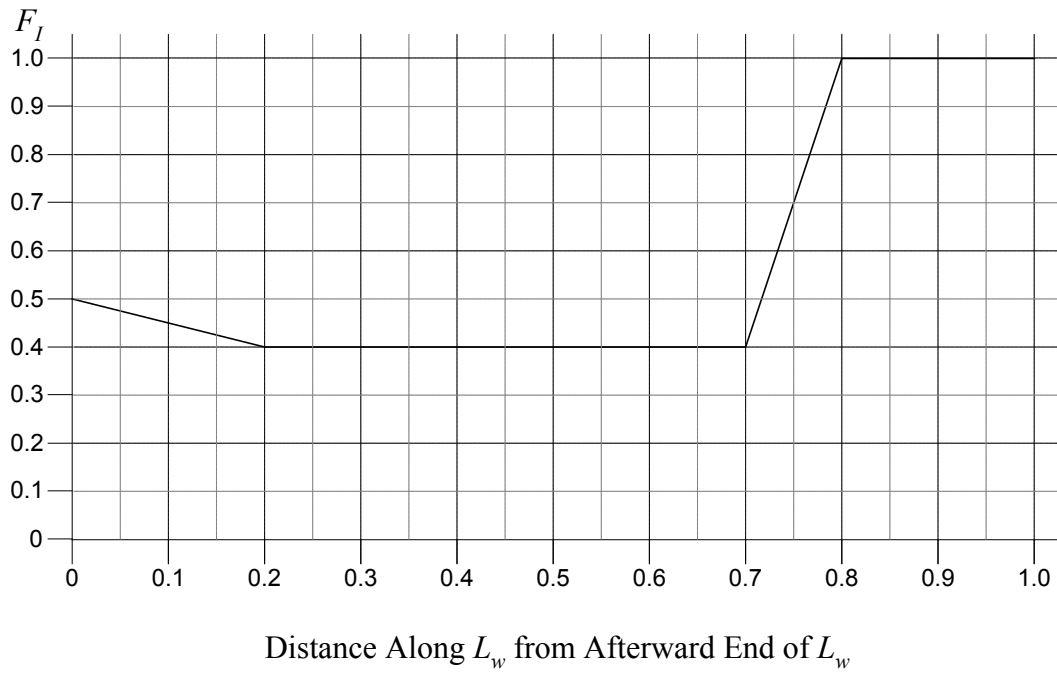


FIGURE 6
Wet Deck Pressure Distribution Factor F_I



PART

3

CHAPTER **2 Hull Structures and Arrangements**

SECTION **3 Plating**

1 Aluminum or Steel

1.1 General

The bottom shell is to extend from the keel to the chine or upper turn of bilge. In general the side shell is to be of the same thickness from its lower limit to the gunwale.

All plating is to meet the requirements for thickness as given in 3-2-3/1.3.

In addition those areas of plating associated with primary hull strength are to meet the buckling criteria as given in 3-2-3/1.5. Where plate panels are subjected to other bending, biaxial, or a combination of stresses, they will be specially considered.

The thickness of the shell plating in way of skegs, shaft struts, hawse pipes, etc. is to be increased by 50% over that obtained from 3-2-3/1.3.

The thickness of water jet tunnels and transverse thruster tubes is to be in accordance with 3-2-3/1.7.

Where the plating forms decks for the access, operation or stowage of vehicles, the plating is in addition to meet the requirements of 3-2-3/1.9.

1.3 Thickness

The thickness of the shell, deck or bulkhead plating is to be not less than obtained by the following equations, whichever is greater:

1.3.1 Lateral Loading

$$t = s \sqrt{\frac{pk}{1000\sigma_a}} \quad \text{mm} \qquad t = s \sqrt{\frac{pk}{\sigma_a}} \quad \text{in.}$$

where

- s = spacing, in mm (in.), of the shell, deck, superstructure, deckhouse or bulkhead longitudinals or stiffeners.
- p = design pressure, in kN/m² (tf/m², psi), given in Section 3-2-2
- k = plate panel aspect ratio factor, given in 3-2-3/Table 1
- σ_a = design stress, in N/mm² (kgf/mm², psi), given in 3-2-3/Table 2

TABLE 1
Aspect Ratio Coefficient for Isotropic Plates

ℓ/s	k	k_1
>2.0	0.500	0.028
2.0	0.497	0.028
1.9	0.493	0.027
1.8	0.487	0.027
1.7	0.479	0.026
1.6	0.468	0.025
1.5	0.454	0.024
1.4	0.436	0.024
1.3	0.412	0.021
1.2	0.383	0.019
1.1	0.348	0.017
1.0	0.308	0.014

Note: s = shorter edge of plate panel, in mm (in.)

ℓ = longer edge of plate panel, in mm (in.)

Intermediate values may be determined by linear interpolation.

TABLE 2
Design Stress, σ_a , Aluminum and Steel

<i>Location</i>		<i>Design Stress, $\sigma_a^{(1)}$</i>	
Bottom Shell	Slamming Pressure	$0.90\sigma_y^{(2)}$	
	Hydrostatic Pressure	$0.55\sigma_y$	
Water Jet Tunnels	Slamming Pressure	$0.60\sigma_y$	
	Hydrostatic Pressure	$0.55\sigma_y$	
Side Shell	Below Bulkhead Deck	Slamming Pressure	$0.90\sigma_y$
		Hydrostatic Pressure	$0.55\sigma_y$
	Above Bulkhead Deck (i.e. foc'sles)	Slamming Pressure	$0.90\sigma_y$
		Hydrostatic Pressure	$0.55\sigma_y$
Deck Plating	Strength Deck	$0.60\sigma_y$	
	Lower Decks/Other Decks	$0.60\sigma_y$	
	Wet Decks	$0.90\sigma_y$	
	Superstructure and Deckhouse Decks	$0.60\sigma_y$	
Bulkheads	Deep Tank	$0.60\sigma_y$	
	Watertight	$0.95\sigma_y$	
Superstructure aft of $0.25L$ from F.P. & Deckhouses	Front, Sides, Ends, Tops	$0.60\sigma_y^{(3)}$	

Notes:

- 1 σ_y = yield strength of steel or of welded aluminum in N/mm² (kgf/mm², psi), but not to be taken greater than 70% of the ultimate strength of steel or welded aluminum
- 2 The design stress for bottom shell plates under slamming pressure may be taken as σ_y for plates outside the midship $0.4L$.
- 3 The design stress for steel deckhouse plates may be taken as $0.90\sigma_y$.

1.3.2 Thickness Based on Secondary Stiffening

$$t_s = 0.01s \text{ mm (in.)} \qquad t_{al} = 0.012s \text{ mm (in.)}$$

where

$$t_s = \text{required thickness for steel craft}$$

$$t_{al} = \text{required thickness for aluminum craft}$$

s is as defined in 3-2-3/1.3.1.

1.3.3 Minimum Thickness

The thickness of shell plating, decks and bulkheads is to be not less than obtained from the following equations:

1.3.3(a) Bottom Shell

$$t_s = 0.44\sqrt{Lq_s} + 2.0 \text{ mm} \qquad t_s = 0.009\sqrt{Lq_s} + 0.08 \text{ in.}$$

$$t_{al} = 0.70\sqrt{Lq_a} + 1.0 \text{ mm} \qquad t_{al} = 0.015\sqrt{Lq_a} + 0.04 \text{ in.}$$

where

$$L = \text{craft length, as defined in 3-1-1/3}$$

$$q_s = 1.0 \text{ for ordinary strength steel; } 245/\sigma_{ys}, (25/\sigma_{ys}, 34000/\sigma_{ys}) \text{ for higher strength steels, but not to be taken less than } 0.72$$

$$\sigma_{ys} = \text{yield strength for higher strength steel, in N/mm}^2 \text{ (kgf/mm}^2, \text{ psi)}$$

$$q_a = 115/\sigma_{ya}, (12/\sigma_{ya}, 17000/\sigma_{ya}) \text{ for aluminum alloys}$$

$$\sigma_{ya} = \text{minimum unwelded yield strength for aluminum alloys, in N/mm}^2 \text{ (kgf/mm}^2, \text{ psi), but not to be taken as more than } 0.7 \text{ of the ultimate tensile strength in the as-welded condition}$$

t_s and t_{al} as defined in 3-2-3/1.3.2. However, t_s is not to be taken less than 3.5 mm (0.14 in.) and t_{al} is not to be taken less than 4.0 mm (0.16 in.)

1.3.3(b) Side Shell

$$t_s = 0.40\sqrt{Lq_s} + 2.0 \text{ mm} \qquad t_s = 0.009\sqrt{Lq_s} + 0.08 \text{ in.}$$

$$t_{al} = 0.62\sqrt{Lq_a} + 1.0 \text{ mm} \qquad t_{al} = 0.013\sqrt{Lq_a} + 0.04 \text{ in.}$$

where t_s and t_{al} are as defined in 3-2-3/1.3.2. However, t_s is not to be taken less than 3.0 mm (0.12 in.) and t_{al} is not to be taken less than 3.5 mm (0.14 in.)

q_s , q_a and L are as defined in 3-2-3/1.3.3(a).

1.3.3(c) Strength Deck

$$t_s = 0.40\sqrt{Lq_s} + 1.0 \text{ mm} \qquad t_s = 0.009\sqrt{Lq_s} + 0.04 \text{ in.}$$

$$t_{al} = 0.62\sqrt{Lq_a} + 1.0 \text{ mm} \qquad t_{al} = 0.013\sqrt{Lq_a} + 0.04 \text{ in.}$$

where t_s and t_{al} are as defined in 3-2-3/1.3.2. However, t_s is not to be taken less than 3.0 mm (0.12 in.) and t_{al} is not to be taken less than 3.5 mm (0.14 in.)

q_s , q_a and L are as defined in 3-2-3/1.3.3(a).

1.3.3(d) Lower Decks, W.T. Bulkheads, Deep Tank Bulkheads

$$t_s = 0.35\sqrt{Lq_s} + 1.0 \text{ mm} \qquad t_s = 0.007\sqrt{Lq_s} + 0.04 \text{ in.}$$

$$t_{al} = 0.52\sqrt{Lq_a} + 1.0 \text{ mm} \qquad t_{al} = 0.011\sqrt{Lq_a} + 0.04 \text{ in.}$$

where t_s , t_{al} , q_s , q_a and L are as defined in 3-2-3/1.3.2. However, t_s is not to be taken less than 3.0 mm (0.12 in.) and t_{al} is not to be taken less than 3.5 mm (0.14 in.).

Where the use is made of special purpose aluminum extrusions or special welding techniques are utilized the minimum plate thickness, as given in 3-2-3/1.3.3 above, will be specially considered based on location, purpose and material grades.

1.5 Buckling Criteria

1.5.1 Uni-axial Compression

1.5.1(a) Ideal Elastic Stress

$$\sigma_E = 0.9m_1E\left(\frac{t_b}{s}\right)^2 \text{ N/mm}^2 \text{ (kgf/mm}^2, \text{ psi)}$$

where

- m_1 = buckling coefficient as given in 3-2-3/Table 3.
- E = for steel: $2.06 \times 10^5 \text{ N/mm}^2$ (21,000 kgf/mm², $30 \times 10^6 \text{ psi}$)
 for aluminum: $6.9 \times 10^4 \text{ N/mm}^2$ (7,000 kgf/mm², $10 \times 10^6 \text{ psi}$)
- t_b = thickness of plating, in mm (in.)
- s = shorter side of plate panel, in mm (in.)
- ℓ = longer side of plate panel, in mm (in.)

1.5.1(b) *Critical Buckling Stress.* The critical buckling stress in compression, σ_c , is determined as follows:

$$\begin{aligned} \sigma_c &= \sigma_E \text{ when } \sigma_E \leq 0.5\sigma_y \\ &= \sigma_y \left(1 - \frac{\sigma_y}{4\sigma_E}\right) \text{ when } \sigma_E > 0.5\sigma_y \end{aligned}$$

where

- σ_y = yield stress of material, in N/mm² (kgf/mm², psi)
Note: Generally the unwelded yield strength may be used, but due account should be made for critical or extensive weld zones.
- σ_E = ideal elastic buckling stress calculated in 3-2-3/1.5.1

1.5.1(c) *Calculated Compressive Stress.* The compressive stresses are given in the following formula:

$$\sigma_a = c_5 \frac{(M_t)y}{I} \text{ N/mm}^2 \text{ (kgf/mm}^2, \text{ psi)}$$

where

- σ_a = working compressive stress in panel being considered, N/mm² (kgf/mm², psi), but generally not less than the following:

$$\frac{f_p}{CQ} \frac{SM_R}{SM_A} \text{ N/mm}^2 \text{ (kgf/mm}^2, \text{ psi)}$$
- c_5 = 10^5 (10⁵, 322,560)

- M_t = maximum total bending moment as given in 3-2-1/1.1.2(e), kN-m (tf-m, Ltf-ft)
 y = vertical distance, in m (ft), from the neutral axis to the considered location
 I = moment of inertia of the hull girder, cm⁴ (in⁴)
 f_p = 175 N/mm² (17.84 kgf/mm², 25,380 psi)
 Q = applicable factor for steel or aluminum as defined in 3-2-1/1.1
 SM_R = hull girder section modulus as required in Section 3-2-1, cm²-m (in²-ft)
 SM_A = section modulus of the hull girder at the location being considered, cm²-m (in²-ft)

1.5.1(d) *Permissible Buckling Stress.* The design buckling stress, σ_c , of plate panels [as calculated in 3-2-3/1.5.1(b)] is to be such that:

$$\sigma_c \geq \sigma_a$$

1.5.2 Shear for Craft 61 m (200 ft) in Length and Over

1.5.2(a) Ideal Elastic Buckling Stress

$$\tau_E = 0.9m_2E \left(\frac{t_b}{s} \right)^2 \quad \text{N/mm}^2 \text{ (kgf/mm}^2, \text{ psi)}$$

where

- m_2 = buckling coefficient as given in 3-2-3/Table 3
 E = for steel: 2.06×10^5 N/mm² (21,000 kgf/mm², 30×10^6 psi)
 for aluminum: 6.9×10^4 N/mm² (7,000 kgf/mm², 10×10^6 psi)
 t_b = thickness of plating, in mm (in.)
 s = shorter side of plate panel, in mm (in.)
 ℓ = longer side of plate panel, in mm (in.)

1.5.2(b) *Critical Buckling Stress.* The critical buckling stress in shear, τ_c , is determined as follows:

$$\tau_c = \tau_E \quad \text{when } \tau_E \leq 0.5 \tau_y$$

$$\tau_c = \tau_y \left(1 - \frac{\tau_y}{4\tau_E} \right) \quad \text{when } \tau_E > 0.5 \tau_y$$

where

- τ_y = minimum shear yield stress of material, in N/mm² (kgf/mm², psi)
 $= \frac{\sigma_{yw}}{\sqrt{3}}$
 σ_{yw} = welded yield strength of material, in N/mm² (kgf/mm², psi).
 τ_E = ideal elastic buckling stress calculated in 3-2-3/1.5.2(a)

1.5.2(c) *Calculated Shear Stress.* The working shear stress, τ_a , in the side shell or longitudinal bulkhead plating is to be calculated by an acceptable and recognized method.

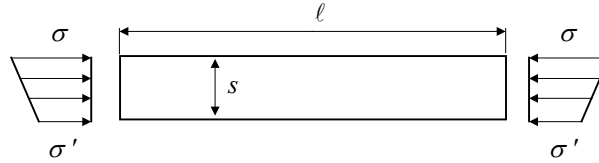
1.5.2(d) *Permissible Buckling Stress.* The design buckling stress, τ_c , of plate panels [as calculated in 3-2-3/1.5.2(b)] is to be such that:

$$\tau_c \geq \tau_a$$

TABLE 3
Buckling Coefficients m_1 and m_2

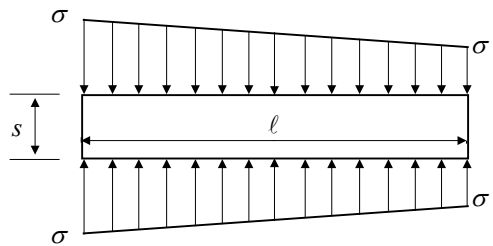
A Uniaxial compression

1. Plates with longitudinal framing, $\ell \geq s$



- a. For $\sigma' = \sigma$, $m_1 = 4$
- b. For $\sigma' = \sigma/3$, $m_1 = 5.8$
- c. For intermediate values m_1 may be obtained by interpolation between a and b

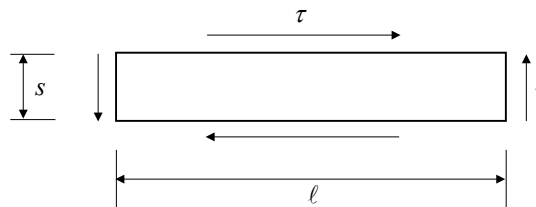
2. Plates with transverse framing, $\ell \geq s$



- a. For $\sigma' = \sigma$, $m_1 = C_2 [1 + (s/\ell)^2]^2$
- b. For $\sigma' = \sigma/3$, $m_1 = 1.45 C_2 [1 + (s/\ell)^2]^2$
- c. For intermediate values m may be obtained by interpolation between a and b

- Values of C_2
- = 1.30 where supported by floors or deep members
 - = 1.21 where stiffeners are T-sections or angle bars
 - = 1.10 where stiffeners are bulb plates
 - = 1.05 where stiffeners are flat bars

B Edge Shear



$$M_2 = 5.34 + 4(s/\ell)^2$$

1.7 Water Jet Tunnels and Transverse Thruster Tubes

1.7.1 Water Jet Tunnels

The thickness for the water jet tunnel plating is to be not less than required by 3-2-3/1.3, neither is it to be less than the greater of the jet manufacturer's recommended thickness or that obtained from the following equation:

$$t = s \sqrt{\frac{p_t k}{1000 \sigma_a}} \quad \text{mm} \qquad t = s \sqrt{\frac{p_t k}{\sigma_a}} \quad \text{in.}$$

where

p_t = maximum positive or negative tunnel design pressure, in kN/m² (tf/m², psi), as provided by the jet manufacturer.

s , k and σ_a are as given in 3-2-3/1.3.

1.7.2 Transverse Thruster Tunnels

The thickness of the tunnel plating for the transverse thrusters is to be not less than required by 3-2-3/1.3, nor less than obtained from the following equation:

$$t = 0.008d\sqrt{Q} + 3.0 \text{ mm} \qquad t = 0.008d\sqrt{Q} + 0.12 \text{ in.}$$

where

d = inside diameter of the tunnel in mm (in.), but is taken as not less than 968 mm (38 in.)

Q is as given in 3-2-1/1.1.

1.9 Decks Provided for the Operation or Stowage of Vehicles

Where provision is to be made for the operation or stowage of vehicles having rubber tires, and after all other requirements are met, the thickness of deck plating is to be not less than obtained from the following equation:

$$t = \sqrt{\frac{\beta W (1 + 0.5n_{xx})}{\sigma_a}} \quad \text{mm (in.)}$$

where

W = static wheel load, in N (lbf)

n_{xx} = average vertical acceleration at the location under consideration as defined in 3-2-2/1.1

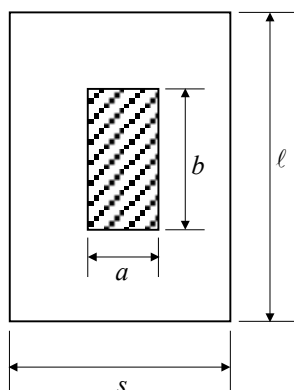
β = as given in 3-2-3/Figure 1

σ_a = design stress for decks, in N/mm² (kgf/mm², psi), given in 3-2-3/Table 2

For wheel loading, strength deck plating thickness is to be not less than 110% of that required by the above equation, and platform deck plating thickness is to be not less than 90% of that required by the above equation.

Where the wheels are close together, special consideration will be given to the use of combined imprint and load. Where the intended operation is such that only the larger dimension of the wheel imprint is perpendicular to the longer edge of the plate panel, then b below may be taken as the smaller wheel imprint dimension, in which case, a is to be the greater one.

FIGURE 1
Values for β



b/s a/s	$\ell/s = 1$						$\ell/s = 1.4$						$\ell/s \geq 2$					
	0	0.2	0.4	0.6	0.8	1	0	0.2	0.4	0.8	1.2	1.4	0	0.4	0.8	1.2	1.6	2
0		1.82	1.38	1.12	0.93	0.76		2.00	1.55	1.12	0.84	0.75		1.64	1.20	0.97	0.78	0.64
0.2	1.82	1.28	1.08	0.90	0.76	0.63	1.78	1.43	1.23	0.95	0.74	0.64	1.73	1.31	1.03	0.84	0.68	0.57
0.4	1.39	1.07	0.84	0.72	0.62	0.52	1.39	1.13	1.00	0.80	0.62	0.55	1.32	1.08	0.88	0.74	0.60	0.50
0.6	1.12	0.90	0.74	0.60	0.52	0.43	1.10	0.91	0.82	0.68	0.53	0.47	1.04	0.90	0.76	0.64	0.54	0.44
0.8	0.92	0.76	0.62	0.51	0.42	0.36	0.90	0.76	0.68	0.57	0.45	0.40	0.87	0.76	0.63	0.54	0.44	0.38
1	0.76	0.63	0.52	0.42	0.35	0.30	0.75	0.62	0.57	0.47	0.38	0.33	0.71	0.61	0.53	0.45	0.38	0.30

Notes:

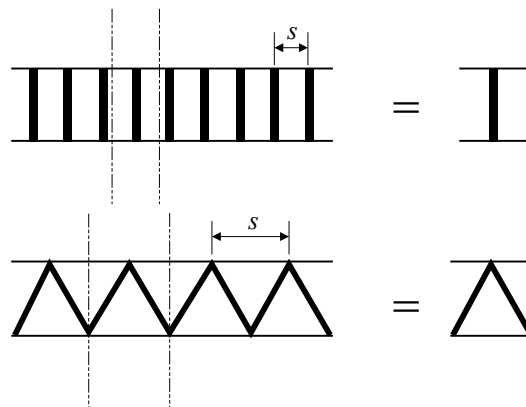
- s = spacing of deck beams or deck longitudinals, in mm (in.)
- ℓ = length of plate pane, in mm (in.)
- a = wheel imprint dimension, in mm (in.), paralleled to the shorter edge, s , of the plate panel
- b = wheel imprint dimension, in mm (in.), parallel to the longer edge, ℓ , of the plate panel

3 Aluminum Extruded Planking, Sandwich Panels and Corrugated Panels

3.1 Aluminum Extruded Planking

Extruded planking is to be reviewed similar to a conventional stiffener and plate combination. The required thickness of the planking between stiffeners is given in 3-2-3/1.3 and 3-2-3/1.5. For box and truss type extrusion, the plate spacing is to be taken as the maximum unsupported span of plate as indicated in 3-2-3/Figure 2. The stiffeners on the planking are to comply with the requirements in 3-2-4/1.3, 3-2-4/1.5 and 3-2-4/1.7. The geometry of stiffeners in box and truss type extrusions is as indicated in 3-2-3/Figure 2. The individual planking pieces are to be attached by continuous welding for the main deck and can be welded intermittently for interior accommodation decks. The intermittent weld for the interior decks is to be sized in accordance with 3-2-13/1 for beams and stiffeners to deck. The use of adhesives for attaching planking members used for weather coverings is to be specially considered.

FIGURE 2
Extruded Planking



3.3 Sandwich Panels

A sandwich panel is a panel with thin skins attached to a thicker core material. These panels are to be typically used on enclosed decks or bulkheads. Where exposed panels are proposed the effects due to heat and the coefficients of thermal expansion are to be addressed. In general, the inner and outer skins are to be of the same thickness. The use of aluminum sandwich panels for helicopter decks and wheel loading will be specially considered. Sandwich panels are to comply with the equations given below:

3.3.1 Section Modulus of Skins

The section modulus about the neutral axis of a strip of sandwich panel, 1 cm (1 in.) wide is not to be less than the following equation:

$$SM = \frac{s^2 pk}{6 \times 10^5 \sigma_a} \text{ cm}^3 \qquad SM = \frac{s^2 pk}{6 \sigma_a} \text{ in}^3$$

where

- s = spacing of the shell or deck longitudinals or superstructure, deckhouse or bulkhead stiffener, in mm (in.). It is always to be the lesser dimension of the unsupported plate panels
- p = design pressure, given in Section 3-2-2
- k = coefficient varying with plate panel aspect ratio, given in 3-2-3/Table 1
- σ_a = design stress, given in 3-2-3/Table 2

3.3.2 Moment of Inertia of Skins

The moment of inertia about the neutral axis of a strip of sandwich panel, 1 cm (1 in.) wide is not to be less than the following equation:

$$I = \frac{s^3 pk_1}{120 \times 10^5 \cdot 0.24E} \text{ cm}^4 \qquad I = \frac{s^3 pk_1}{0.24E} \text{ in}^4$$

where

- s = spacing of the shell or deck longitudinals or superstructure, deckhouse or bulkhead stiffener, in mm (in.). It is always to be the lesser dimension of the unsupported plate panels
- p = design pressure, given in Section 3-2-2
- k_1 = coefficient varying with plate panel aspect ratio, given in 3-2-3/Table 1
- E = tensile modulus of aluminum, in N/mm² (kgf/mm², psi), as defined in 3-2-3/1.5.2

3.3.3 Core Shear Strength

The thickness of core and sandwich is to be not less than given by the following equation:

$$\frac{d_o + d_c}{2} = \frac{vps}{1000\tau_a} \quad \text{mm} \qquad \frac{d_o + d_c}{2} = \frac{vps}{\tau} \quad \text{in.}$$

where

- d_o = overall thickness of sandwich, in mm (in.)
- d_c = thickness of core, in mm (in.)
- v = coefficient varying with plate panel aspect ratio, given in 3-2-3/Table 6
- s = lesser dimension of plate panel, in mm (in.)
- p = design pressure, in kN/m² (tf/m², psi), as defined in Section 3-2-2
- τ = design stress, N/mm² (kgf/mm², psi), as shown in 3-2-3/Table 7.

3.3.4 Testing

The core material and the attachment of the skins to the core are to be tested in accordance with the requirements in 2-6-5/11

3.3.5 Attachment

Typically, beams and stiffeners are not to be considered as effectively attached. Panels are not to be welded to unless the possible damage from heat is addressed. The panels are to be bolted to surrounding structure. The use of adhesives will be specially considered.

3.5 Corrugated Panels

3.5.1 Plating

The plating of corrugated panels is to be of the thickness required by 3-2-3/1.3 with the following modification. The spacing to be used is the greater of dimensions a or c as indicated in 3-2-4/Figure 3.

5 Fiber Reinforced Plastic

5.1 General

The shell, decks and bulkheads may be either single skin or sandwich construction. Where both are used, a suitable transition is to be obtained between them with a minimum 12:1 taper ratio.

The bottom shell is to extend to the chine or upper bilge turn. A suitable transition is to be obtained between the bottom and side shell plating. The shell thickness in way of the keel is to be 50% greater and in way of shaft struts and skegs is to be 100% greater than the thickness required by 3-2-3/5.5.1 or 3-2-3/5.5.2, as applicable. For this purpose, pressure p_b as obtained from 3-2-2/1.1 or 3-2-2/3.1 and actual frame spacing at the location of the member are to be used for 3-2-3/5.5.1. Suitable framing reinforcement is to be provided in way of shaft struts. Bow thruster tube thickness is to be equivalent to the surrounding shell thickness.

The shell, deck or bulkhead laminates may be bi-directional (having essentially same strength and elastic properties in the two in-plane principal axes of the shell, deck or bulkhead) or uni-directional (having different strength or elastic properties in the two principal axes of the shell, deck or bulkhead panels). Bonding angles or tapes are to have essentially same strength and elastic properties as the plating laminate being bonded, and are in general to be in accordance with Section 3-2-6.

5.3 Fiber Reinforcement

The basic laminate given in Part 2, Chapter 6 or other approved laminate of glass, aramid or carbon fiber in mat, woven roving, cloth, knitted fabric or non-woven uni-directional reinforcing, plies may be used. Equivalent strength and thickness of other than E-glass base laminate is to be assessed in a laminate stack program on the basis of first ply failure. For the shell and deck a sufficient number of plies are to be laid-up with the warp in the 0° (longitudinal) axis. Warp and fill directions are to be aligned parallel to the respective edges of the shell and deck panels as closely as practicable. Depending on the directionality and fiber orientation of these plies, other plies may be required or permitted in the 90° (transverse) axis; reinforcing plies in other axes such as +45° (diagonal) may also be used, when approved.

Where the strength and stiffness in the two principal axes of the panel are different, panel bending in each of the panel principal axes is to be considered. See 3-2-3/5.5.2 and 3-2-3/5.7.2.

5.5 Single Skin Laminate

5.5.1 With Essentially Same Properties in 0° and 90° Axes

The thickness of the shell, deck or bulkhead plating is to be not less than given by the following equations:

5.5.1(a) All Plating

$$t = sc \sqrt{\frac{pk}{1000\sigma_a}} \text{ mm} \qquad t = sc \sqrt{\frac{pk}{\sigma_a}} \text{ in.}$$

5.5.1(b) All Plating

$$t = sc^3 \sqrt{\frac{pk_1}{1000k_2E_F}} \text{ mm} \qquad t = sc^3 \sqrt{\frac{pk_1}{k_2E_F}} \text{ in.}$$

5.5.1(c) Strength deck and shell

$$t = k_3(c_1 + 0.26L) \sqrt{q_1} \text{ mm} \qquad t = k_3(c_1 + 0.0031L) \sqrt{q_1} \text{ in.}$$

L is generally not to be taken less than 12.2 m (40 ft).

5.5.1(d) Strength deck and bottom shell

$$t = \frac{s}{k_b} \sqrt{\frac{0.6\sigma_{uc}}{E_c}} \sqrt{\frac{SM_R}{SM_A}} \text{ mm (in.)}$$

where

- s = spacing of the shell or deck longitudinals or superstructure, deckhouse or bulkhead stiffeners, in mm (in.). It is always to be the lesser dimension of the unsupported plate panels
- c = factor for plate curvature in the direction parallel to s , given by $(1 - A/s)$, but is not to be taken less than 0.70
- A = distance, in mm (in.), measured perpendicular from the chord length, s , to the highest point of the curved plate arc between the panel edges
- p = design pressure given in Section 3-2-2
- k or k_1 = coefficient varying with plate panel aspect ratio, given in 3-2-3/Table 1
- k_b = 2.5 with longitudinal framing
- = 2.5 with transverse framing and panel aspect ratio of 1.0
- = 1.0 with transverse framing and panel aspect ratio 2.0 to 4.0
- σ_a = design stress given in 3-2-3/Table 4

- k_2 = for bottom plating: 0.015 for patrol boats and similar service craft, 0.01 for other craft
 = for side plating: 0.020 for patrol boats and similar service craft, 0.015 for other craft
 = for superstructures and deckhouse fronts: 0.025
 = for other plating: 0.010
- E_F = flexural modulus of laminate, in N/mm² (kgf/mm², psi), in the direction parallel to s
- q_1 = $170/F$ (15.5/ F , 25,000/ F)
- L = craft length, in m (ft), as defined in 3-1-1/3
- c_1 = 5.7 mm (0.225 in.)
- k_3 = 1.2 for bottom shell structure
 = 1.0 for side shell and deck structure
- E_c = compressive modulus of elasticity in N/mm² (kgf/mm², psi)
- F = minimum flexural strength of laminate, in N/mm² (kgf/mm², psi)
- σ_{uc} = minimum compressive strength of laminate, in N/mm² (kgf/mm², psi)
- SM_R = required hull-girder section modulus given in Section 3-2-1
- SM_A = proposed hull-girder section modulus of midship section

TABLE 4
Design Stresses for FRP, σ_d

Bottom Shell	$0.33 \sigma_u$
Side Shell	$0.33 \sigma_u$
Decks	$0.33 \sigma_u$
Superstructure and Deckhouses – Front, Sides, Ends, and Tops	$0.33 \sigma_u$
Tank Bulkheads	$0.33 \sigma_u$
Watertight Bulkheads	$0.50 \sigma_u$

For single skin laminates:

$$\sigma_u = \text{minimum flexural strength, in N/mm}^2 \text{ (kgf/mm}^2 \text{, psi)}$$

For sandwich laminates:

$$\sigma_u = \text{for shell or deck outer skin, minimum tensile strength, in N/mm}^2 \text{ (kgf/mm}^2 \text{, psi)}$$

$$\sigma_u = \text{for shell or deck inner skin, minimum compressive strength, in N/mm}^2 \text{ (kgf/mm}^2 \text{, psi)}$$

$$\sigma_u = \text{for bulkheads, lesser of tensile or compressive strength, in N/mm}^2 \text{ (kgf/mm}^2 \text{, psi)}$$

Note: σ_u is to be verified from the approved test results. See Section 2-6-5.

5.5.2 With Different Properties in 0° and 90° Axes

For laminates with different strength and elastic properties in the 0° and 90° axes where the strength is less or the stiffness greater in the panel direction perpendicular to s , the thickness is to be also not less than given by the following equations:

5.5.2(a)

$$t = sc \sqrt{\frac{pk_s}{1000\sigma_{as}}} \text{ mm} \qquad t = sc \sqrt{\frac{pk_s}{\sigma_{as}}} \text{ in.}$$

5.5.2(b)

$$t = sc \sqrt{\frac{pk_\ell}{1000\sigma_{al}}} \sqrt[4]{\frac{E_\ell}{E_s}} \text{ mm} \qquad t = sc \sqrt{\frac{pk_\ell}{\sigma_{al}}} \sqrt[4]{\frac{E_\ell}{E_s}} \text{ in.}$$

where

- k_s, k_ℓ = coefficient for plate panel aspect ratio, given in 3-2-3/Table 5
- σ_{as} = design stress, given in 3-2-3/Table 4, based on strength properties in the direction parallel to s
- E_s = flexural modulus of laminate, in N/mm² (kgf/mm², psi), in the direction parallel to s
- σ_{al} = design stress, given in 3-2-3/Table 4, based on strength properties in the direction perpendicular to s
- E_ℓ = flexural modulus of laminate, in N/mm² (kgf/mm², psi), in the direction perpendicular to s

s, c and p are as defined in 3-2-3/5.5.

TABLE 5
Aspect Ratio Coefficient for Isotropic Plates

$(\ell/s) \sqrt[4]{E_s / E_\ell}$	k_s	k_ℓ
> 2.0	0.500	0.342
2.0	0.497	0.342
1.9	0.493	0.342
1.8	0.487	0.342
1.7	0.479	0.342
1.6	0.468	0.342
1.5	0.454	0.342
1.4	0.436	0.342
1.3	0.412	0.338
1.2	0.383	0.333
1.1	0.348	0.323
1.0	0.308	0.308

5.7 Sandwich Laminate

5.7.1 Laminate with Essentially Same Bending Strength and Stiffness in 0° and 90° Axes

In general the outer and inner skins are to be similar in lay-up and in strength and elastic properties. Special consideration will be given where this is not the case. In general, single skin laminate is to be used in way of the keel and in way of hull appendages such as shaft struts, skegs and rudders and in way of deck fittings, bolted connections, and other areas of concentrated local loads.

The section modulus and moment of inertia about the neutral axis of a strip of sandwich panel, 1 cm (1 in.) wide are to be not less than given by the following equations:

5.7.1(a)

$$SM_o = \frac{(sc)^2 pk}{6 \times 10^5 \sigma_{ao}} \text{ cm}^3 \qquad SM_o = \frac{(sc)^2 pk}{6 \sigma_{ao}} \text{ in}^3$$

5.7.1(b)

$$SM_i = \frac{(sc)^2 pk}{6 \times 10^5 \sigma_{ai}} \text{ cm}^3 \qquad SM_i = \frac{(sc)^2 pk}{6 \sigma_{ai}} \text{ in}^3$$

5.7.1(c)

$$I = \frac{(sc)^3 pk_1}{120 \times 10^5 k_2 E_{tc}} \text{ cm}^4 \qquad I = \frac{(sc)^3 pk_1}{12 k_2 E_{tc}} \text{ in}^4$$

where

SM_o = required section modulus, in cm^3 (in^3), to outer skin.

SM_i = required section modulus, in cm^3 (in^3), to inner skin.

I = required moment of inertia, in cm^4 (in^4)

σ_{ao} = design stress, for outer skin, given in 3-2-3/Table 4, based on strength of outer skin in direction parallel to s .

σ_{ai} = design stress, for inner skin, given in 3-2-3/Table 4, based on strength of inner skin in direction parallel to s .

E_{tc} = $0.5 (E_c + E_t)$

E_c = mean of compressive moduli of inner and outer skins, in N/mm^2 (kgf/cm^2 , psi)

E_t = means of tensile moduli of inner and outer skins, in N/mm^2 (kgf/cm^2 , psi)

s , c , p , k , k_1 and k_2 are as defined in 3-2-3/5.5.

5.7.2 Laminates with Different Bending Strength and Stiffness in 0° and 90° Axes

Where the strength is less or the stiffness greater in the direction perpendicular to s , the section modulus and moment of inertia about the neutral axis of a strip of sandwich, 1 cm (1 in.) wide are also to be not less than given by the following equations:

5.7.2(a) *In direction parallel to s*

$$SM_o = \frac{(sc)^2 pk_s}{6 \times 10^5 \sigma_{aso}} \text{ cm}^3 \qquad SM_o = \frac{(sc)^2 pk_s}{6 \sigma_{aso}} \text{ in}^3$$

5.7.2(b) *In direction parallel to ℓ*

$$SM_o = \frac{(sc)^2 pk_\ell}{6 \times 10^5 \sigma_{a\ell o}} \sqrt{\frac{E_\ell}{E_s}} \text{ cm}^3 \qquad SM_o = \frac{(sc)^2 pk_\ell}{6 \sigma_{a\ell o}} \sqrt{\frac{E_\ell}{E_s}} \text{ in}^3$$

5.7.2(c) *In direction parallel to s*

$$SM_i = \frac{(sc)^2 pk_s}{6 \times 10^5 \sigma_{asi}} \text{ cm}^3 \qquad SM_i = \frac{(sc)^2 pk_s}{6 \sigma_{asi}} \text{ in}^3$$

5.7.2(d) *In direction parallel to ℓ*

$$SM_i = \frac{(sc)^2 pk_\ell}{6 \times 10^5 \sigma_{a\ell i}} \sqrt{\frac{E_\ell}{E_s}} \text{ cm}^3 \qquad SM_i = \frac{(sc)^2 pk_\ell}{6 \sigma_{a\ell i}} \sqrt{\frac{E_\ell}{E_s}} \text{ in}^3$$

5.7.2(e) In direction parallel to s

$$I = \frac{(sc)^2 pk_1}{120 \times 10^5 k_2 E_s} \text{ cm}^4 \qquad I = \frac{(sc)^2 pk_1}{12k_2 E_s} \text{ in}^4$$

where

- SM_o = required section modulus, in cm^3 (in^3), to outer skin.
- SM_i = required section modulus, in cm^3 (in^3), to inner skin.
- k_ℓ, k_s = modified coefficient for plate panel aspect ratio, given in 3-2-3/Table 5.
- σ_{aso} = design stress, for outer skin, given in 3-2-3/Table 4, based on strength properties in direction parallel to s .
- σ_{alo} = design stress, for outer skin, given in 3-2-3/Table 4, based on strength properties in direction perpendicular to s .
- σ_{asi} = design stress for inner skin, given in 3-2-3/Table 4, based on strength properties in direction parallel to s .
- σ_{ali} = design stress, for inner skin, given in 3-2-3/Table 4, based on strength properties in direction perpendicular to s .
- E_s = $0.5 (E_{ts} + E_{cs})$
- E_ℓ = $0.5 (E_{t\ell} + E_{c\ell})$
- E_{ts}, E_{cs} = respectively, mean of tensile moduli of inner and outer skins, and mean of compressive moduli of inner and outer skins, in N/mm^2 (kgf/cm^2 , psi) in direction parallel to s .
- $E_{t\ell}, E_{c\ell}$ = respectively, mean of tensile moduli of inner and outer skins, and mean of compressive moduli of inner and outer skins, in N/mm^2 (kgf/cm^2 , psi) in direction parallel to ℓ .

s, c, p, k_1, k_2 and E_{tc} are as defined in 3-2-3/5.5.

5.7.3 Shear Strength

The thickness of core and sandwich laminate is to be not less than given by the following equation. Special consideration will be given where cores differing from those in Part 2, Chapter 6 are proposed. See also 3-2-3/5.7.5 for minimum thickness of skin.

$$\frac{d_o + d_c}{2} = \frac{vps}{1000\tau} \text{ mm} \qquad \frac{d_o + d_c}{2} = \frac{vps}{\tau} \text{ in.}$$

where

- d_o = overall thickness of sandwich, excluding gel coat, in mm (in.)
- d_c = thickness of core, in mm (in.)
- v = coefficient varying with plate panel aspect ratio, given in 3-2-3/Table 6. Where the elastic properties of the skins are different in the principal axes, v is to be taken not less than 0.5.
- s = lesser dimension of plate panel, in mm (in.)
- p = design pressure, in kN/m^2 (tf/m^2 , psi), as defined in Section 3-2-2.
- τ = design stress, in N/mm^2 (kgf/mm^2 , psi), as shown in 3-2-3/Table 7.

Where cores are scored to facilitate fitting, the scores are to be filled with putty or resin.

The density of polyvinyl chloride foam cores in the shell plating is to be not less than given in the following table:

<i>Location</i>	<i>Density kg/m³ (lbs/ft³)</i>	<i>Minimum Density kg/m³ (lbs/ft³)</i>
Bottom forward of $0.4L_{WL}$; $V \geq 25$ kts	$4d_c$ (6.4 d_c)	120 (7.5)
Bottom forward of $0.4L_{WL}$; $V < 25$ kts	$4d_c$ (6.4 d_c)	100 (6.25)
elsewhere; $V \geq 25$ kts	$3d_c$ (4.8 d_c)	100 (6.25)
elsewhere; $V < 25$ kts	$3d_c$ (4.8 d_c)	80 (5.00)
Side forward $0.4L_{WL}$	$2.5d_c$ (4.0 d_c)	100 (6.25)
elsewhere	$2.0d_c$ (3.2 d_c)	80 (5.00)

TABLE 6
Coefficient ν for FRP Sandwich Panels Shear Strength

<i>Plate Panel Aspect Ratio ℓ/s</i>	<i>ν</i>
>2.0	0.500
2.0	0.500
1.9	0.499
1.8	0.499
1.7	0.494
1.6	0.490
1.5	0.484
1.4	0.478
1.3	0.466
1.2	0.455
1.1	0.437
1.0	0.420

s = shorter edge of plate panel, in mm (in.)

ℓ = longer edge of plate panel, in mm (in.)

Note: Values of ν less than 0.5 may be used only where the inner and outer skins have essentially the same strength and elastic properties in the 0° and 90° axes.

TABLE 7
Core Shear Design Strength

<i>Core Material</i>	<i>Design Core Shear Strength</i>
Balsa Wood	$0.3 \tau_u$
PVC*	$0.4 \tau_u$

* May be taken as $0.55 \tau_u$ where shear elongation exceeds 40%.

τ_u = minimum core shear strength, in N/mm² (kgf/mm², psi)

5.7.4 Skin Stability

The skin buckling stress σ_c , given by the following equation, is in general to be not less than $2.0\sigma_{ai}$ and $2.0\sigma_{ao}$.

$$\sigma_c = 0.6\sqrt[3]{E_s \cdot E_{cc} \cdot G_{cc}}$$

where

- E_s = compressive modulus of skins, in N/mm² (kgf/mm², psi), in 0° and 90° in-plane axis of panel
- E_{cc} = compressive modulus of core, in N/mm² (kgf/mm², psi), perpendicular to skins
- G_{cc} = core shear modulus, in N/mm² (kgf/mm², psi), in the direction parallel to load

5.7.5 Minimum Skin Thickness

After all other requirements are met, the skin thicknesses of laminates complying with basic laminate requirements of Part 2, Chapter 6 are in general to be not less than given by the following equations:

$$t_{os} = 0.35k_3 (C_1 + 0.26L) \text{ mm}$$

$$t_{os} = 0.35k_3 (C_1 + 0.0031L) \text{ in.}$$

$$t_{is} = 0.25k_3 (C_1 + 0.26L) \text{ mm}$$

$$t_{is} = 0.25k_3 (C_1 + 0.0031L) \text{ in.}$$

where

- t_{os} = thickness of outer skin, in mm (in.)
- t_{is} = thickness of inner skin, in mm (in.)
- k_3 = 1.2 Bottom Shell
 = 1.0 Side Shell and Deck
- C_1 = 5.7 mm (0.225 in.)
- L = craft length, in m (ft), as defined in 3-1-1/3, generally not to be taken as less than 12.2 m (40 ft).

5.7.6 Wheel Loading

Special consideration will be given to the required thickness where provision is made for the operation or stowage of vehicles having rubber tires after all other requirements are met.

7 Plating Subject to Specific Payloads

A first principles analysis is to be performed for all plates that are subject to a specific payload. The maximum stresses and deflections in these plates are not to exceed the stresses given in 3-2-3/Table 8.

TABLE 8

		Steel	Aluminum	FRP	
				σ	δ
Human Load		---	---	$0.33\sigma_u$	$0.01s$
Helicopter Decks ⁽²⁾	Overall Dist. Loading	$0.60\sigma_y$	$0.6\sigma_{yw}$	See Note 1	See Note 1
	Landing Impact Loading	σ_y	σ_{yw}	See Note 1	See Note 1
	Stowed Aircraft Loading	σ_y	σ_{yw}	See Note 1	See Note 1

σ_y = yield strength of steel in N/mm² (kgf/mm², psi)

σ_{yw} = welded yield strength of aluminum in N/mm² (kgf/mm², psi)

s = panel spacing

For single skin laminates:

σ_u = minimum flexural strength, in N/mm² (kgf/mm², psi)

For sandwich laminates:

σ_u = for shell or deck outer skin, minimum tensile strength, in N/mm² (kgf/mm², psi)

σ_u = for shell or deck inner skin, minimum compressive strength, in N/mm² (kgf/mm², psi)

σ_u = for bulkheads, lesser of tensile or compressive strength, in N/mm² (kgf/mm², psi)

Notes: σ_u is to be verified from the approved test results. See Section 2-6-5

1 Composites will be specially considered for use in this location.

2 The minimum plate thickness is generally not to be less than obtained from the following:

Beam Spacing	t_s	t_{al}
460 mm (18 in.)	4.0 mm (0.16 in.)	$0.9t_s\sqrt{Q}$
610 mm (24 in.)	5.0 mm (0.20 in.)	$0.9t_s\sqrt{Q}$
760 mm (30 in.)	6.0 mm (0.24 in.)	$0.9t_s\sqrt{Q}$

t_s = required thickness for steel

t_{al} = required thickness for aluminum

Q = material factor as defined in 3-2-1/1.1

CHAPTER **2** **Hull Structures and Arrangements**SECTION **4** **Internals****1** **Aluminum and Steel****1.1** **General**

Structural arrangements and details are to be in accordance with Sections 3-2-5 and 3-2-6. Reference is to be made to 1-1-4/5 regarding requirement for direct analysis of primary structure (i.e., transverse webs and girders). The scantlings given in this section are minimum values. Direct analysis may be specifically required by the guide or may be submitted by designers in support of alternative arrangements and scantlings. ABS may, when requested, carry out direct analysis on behalf of designers.

1.3 **Strength and Stiffness****1.3.1** **Section Modulus**

The ends of members are to be effectively attached to the supporting structure. The section modulus of each longitudinal, stiffener, transverse web, stringer and girder is to be not less than given by the following equation:

$$SM = \frac{83.3 \times ps\ell^2}{\sigma_a} \quad \text{cm}^3 \qquad SM = \frac{144 \times ps\ell^2}{\sigma_a} \quad \text{in}^3$$

where

- p = design pressure, in kN/m² (tf/m², psi), given in 3-2-2/1 or 3-2-2/5
- s = spacing, in m (ft), of the longitudinal, stiffener, transverse web or girder, etc.
- ℓ = length, in m (ft), of the longitudinal, stiffener, transverse web or girder, between supports; where bracketed end connections are supported by bulkheads, ℓ may be measured onto the bracket, the distance given on 3-1-2/Figure 1, provided both bracket arms are about the same length. Where transverse members span chines or “knuckles,” ℓ is to be measured as shown in 3-2-4/Figure 1 and 3-2-4/Figure 2.
- σ_a = design stress, in N/mm² (kgf/mm², psi) as given in 3-2-4/Table 1

Stiffeners without end attachments are permitted on watertight bulkheads provided the section modulus is increased by 50%, and provided the bulkhead plating and boundary can transmit the shear forces on the stiffeners.

FIGURE 1
Transverse Side Frame

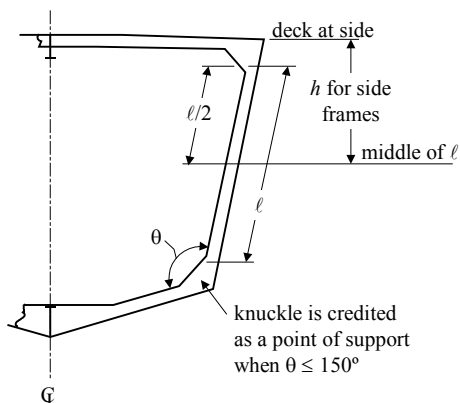


FIGURE 2
Transverse Side Frame

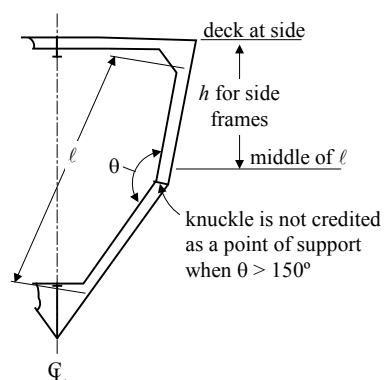


TABLE 1
Design Stress, σ_a

<i>Location</i>	<i>Steel and Aluminum</i>	<i>FRP</i>
Bottom Longitudinals – Slamming Pressure	$0.65 \sigma_y$	$0.33 \sigma_u$
Bottom Longitudinals – Sea Pressure	$0.50 \sigma_y$	$0.40 \sigma_u$
Side Longitudinals – Slamming Pressure	$0.60 \sigma_y$	$0.40 \sigma_u$
Side Longitudinals – Sea Pressure	$0.50 \sigma_y$	$0.40 \sigma_u$
Deck Longitudinals – Strength Decks	$0.33 \sigma_y$	$0.40 \sigma_u$
Deck Longitudinals – Other Decks	$0.40 \sigma_y$	$0.40 \sigma_u$
Wet Deck Longitudinals	$0.75 \sigma_y$	$0.40 \sigma_y$
Bottom Transverse and Girders – Slamming Pressure	$0.80 \sigma_y$	$0.33 \sigma_u$
Bottom Transverses and Girders – Sea Pressure	$0.60 \sigma_y$	$0.33 \sigma_u$
Side Transverses and Girders – Slamming Pressure	$0.80 \sigma_y$	$0.33 \sigma_u$
Side Transverses and Girders – Sea Pressure	$0.60 \sigma_y$	$0.33 \sigma_u$
Deck Transverses and Girders– Strength Deck	$0.75 \sigma_y$	$0.33 \sigma_u$
Deck Transverses and Girders– Other Decks	$0.75 \sigma_y$	$0.33 \sigma_u$
Wet Deck Transverses and Girders	$0.75 \sigma_y$	$0.33 \sigma_y$
Watertight Bulkheads	$0.85 \sigma_y$	$0.50 \sigma_u$
Tank Bulkheads	$0.60 \sigma_y$	$0.33 \sigma_u$
Superstructure and Deckhouse	$0.70 \sigma_y$	$0.33 \sigma_u$

σ_y = minimum yield strength, unwelded condition, in N/mm² (kgf/mm², psi). For aluminum, minimum yield stress, welded condition, in N/mm², (kgf/mm², psi)

σ_u = ultimate tensile strength, in N/mm² (kgf/mm², psi)

1.3.2 Moment of Inertia

The moment of inertia of each longitudinal, stiffener, transverse web, stringer or girder, including the plating to which it is attached, is to be not less than given by the following equation:

$$I = \frac{260ps\ell^3}{K_4E} \quad \text{cm}^4 \qquad I = \frac{54ps\ell^3}{K_4E} \quad \text{in}^4$$

where

K_4	=	0.0015	for shell and deep tank girders, stringers and transverse webs, constructed of steel.
	=	0.0011	for deck girders and transverses constructed of steel.
	=	0.0021	for shell and deep tank stringers and transverse webs constructed of aluminum.
	=	0.0018	for deck girder and transverses constructed of aluminum.
E	=	$2.06 \times 10^5 \text{ N/mm}^2$ (21,000 kgf/mm ² , $30 \times 10^6 \text{ psi}$)	for steel
	=	$6.9 \times 10^4 \text{ N/mm}^2$ (7,000 kgf/mm ² , $10 \times 10^6 \text{ psi}$)	for aluminum

p , s and ℓ are as given in 3-2-4/3.1.

1.5 Elastic Buckling of Longitudinal Members

The moment of inertia of the deck or shell longitudinal together with attached plating is not to be less than to satisfy the following criteria:

1.5.1 Axial Compression

The critical buckling stress σ_E of a beam-column (i.e., the longitudinal and the associated effective plating) with respect to axial compression may be obtained from the following equation:

$$\sigma_E = \frac{EI_a}{C_1 A \ell^2} \quad \text{N/mm}^2 \text{ (kgf/mm}^2, \text{ psi)}$$

where

E	=	as defined in 3-2-4/1.3.2
I_a	=	moment of inertia, cm ⁴ (in ⁴), of longitudinal, including plate flange
C_1	=	1000 (1000, 14.4)
A	=	cross-sectional area, in cm ² (in ²), of longitudinal, including plate flange
ℓ	=	span of longitudinal, in m (ft)

1.5.2 Torsional/Flexural Buckling

The critical torsional/flexural buckling stress with respect to axial compression of a longitudinal including its associated plate may be obtained from the following equation:

$$\sigma_E = \frac{\pi^2 EI_w}{10c_1 I_p \ell^2} \left(m^2 + \frac{K}{m^2} \right) + 0.385E \frac{I_t}{I_p} \quad \text{N/mm}^2 \text{ (kgf/mm}^2, \text{ psi)}$$

where

$$K = c_2 \frac{C \ell^4}{\pi^4 EI_w}$$

m	=	1	for $0 < K \leq 4$
		2	for $4 < K \leq 36$
		3	for $36 < K \leq 144$
		4	for $144 < K \leq 400$
E	=	as defined in 3-2-4/1.3.2	
c_2	=	10^6 (10^6 , 20736)	
I_t	=	St. Venant's moment of inertia, in cm^4 (in^4), of profile (without plate flange)	
	=	$c_3 \frac{h_w t_w^3}{3}$	for flat bars (slabs)
	=	$c_3 \frac{1}{3} \left[h_w t_w^3 + b_f t_f^3 \left(1 - 0.63 \frac{t_f}{b_f} \right) \right]$	for flanged profiles
c_3	=	10^{-4} (10^{-4} , 1.0)	
I_p	=	polar moment of inertia, in cm^4 (in^4), of profile about connection of stiffener to plate	
	=	$c_3 \frac{h_w^3 t_w}{3}$	for flat bars (slabs)
	=	$c_3 \left(\frac{h_w^3 t_w}{3} + h_w^2 b_f t_f \right)$	for flanged profiles
I_w	=	warping constant, in cm^6 (in^6), of profile about connection of stiffener to plate	
	=	$c_4 \frac{h_w^3 t_w^3}{36}$	for flat bars (slabs)
	=	$c_4 \left(\frac{t_f b_f^3 h_w^2}{12} \right)$	for "Tee" profiles
	=	$c_4 \frac{b_f^3 h_w^2}{12(b_f + h_w)^2} [t_f(b_f^2 + 2b_f h_w + 4h_w^2) + 3t_w b_f h_w]$	for angles and bulb profiles
c_4	=	10^{-6} (10^{-6} , 1.0)	
h_w	=	web height, in mm (in.)	
t_w	=	web thickness, in mm (in.)	
b_f	=	flange width, in mm (in.)	
t_f	=	flange thickness, in mm (in.)	
ℓ	=	span of member, in m (ft)	
s	=	spacing of member, in mm (in.)	

- C = spring stiffness exerted by supporting plate panel
- $$= \frac{k_p E t_p^3}{3s \left(1 + \frac{1.33 k_p h_w t_p^3}{s t_w^3} \right)} \text{ N (kgf, lbf)}$$
- k_p = $1 - \eta_p$, not to be taken less than zero. For flanged profiles k_p need not be taken less than 0.1.
- t_p = plate thickness, in mm (in.)
- $$\eta_p = \frac{\sigma_a}{\sigma_{Ep}}$$
- σ_a = calculated compressive stress. For longitudinals, members see 3-2-4/1.5.4
- σ_{Ep} = elastic buckling stress of supporting plate as calculated in 3-2-3/1.5.1(a)

1.5.3 Critical Buckling Stress

The critical buckling stress in compression, σ_c , is determined as follows:

$$\begin{aligned} \sigma_c &= \sigma_E && \text{when } \sigma_E \leq 0.5 \sigma_y \\ &= \sigma_y \left(1 - \frac{\sigma_y}{4\sigma_E} \right) && \text{when } \sigma_E > 0.5 \sigma_y \end{aligned}$$

where

- σ_y = yield strength of material, in N/mm² (kgf/mm², psi)
- Note:* Generally the unwelded yield strength may be used, but due account should be made for critical or extensive weld zones.
- σ_E = ideal elastic buckling stress calculated in 3-2-3/1.5.1

1.5.4 Calculated Compressive Stress

$$\sigma_a = c_5 \frac{(M_t)y}{I} \text{ N/mm}^2 \text{ (kgf/mm}^2, \text{ psi)}$$

where

- σ_a = working compressive stress in panel being considered, N/mm² (kgf/mm², psi), but generally not less than the following:
- $$= \frac{C_1}{Q} \frac{SM_R}{SM_A} \text{ N/mm}^2 \text{ (kgf/mm}^2, \text{ psi)}$$
- c_5 = 10^5 (10^5 , 322,560)
- M_t = maximum total bending moment as given in 3-2-1/1.1.2(e), kN-m (tf-m, Ltf-ft)
- y = vertical distance, in m (ft), from the neutral axis to the considered location
- I = moment of inertia of the hull girder, cm⁴ (in⁴)
- C_1 = 175 N/mm² (17.84 kgf/mm², 25,380 psi)
- SM_R = hull girder section modulus, as required in Section 3-2-1, cm²-m (in²-ft)
- SM_A = section modulus of the hull girder at the location being considered, cm²-m (in²-ft)
- Q = material factor as given in 3-2-1/1.1

1.5.5 Design Buckling Stress

The design buckling stress, σ_c , is to be such that:

$$\sigma_c \geq \beta \sigma_a$$

where

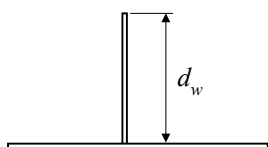
$$\begin{aligned} \beta &= 1.10 && \text{for the web plating of members} \\ &= 1.20 && \text{for overall buckling of members} \end{aligned}$$

1.5.6 Web and Flange Buckling

Local buckling is considered satisfactory provided the following proportions are not exceeded.

1.5.6(a) Flat bars

$$d_w/t_w \leq 0.5(E/\sigma_y)^{1/2} C_2$$



1.5.6(b) Built-up Sections, Angle Bars and Tee Bars

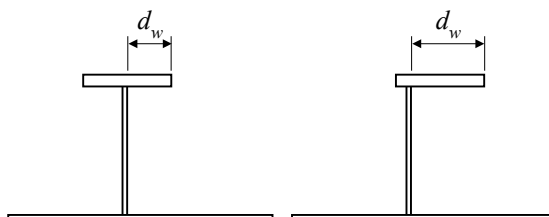
$$d_w/t_w \leq 1.5(E/\sigma_y)^{1/2} C_2$$

1.5.6(c) Bulb Plates

$$d_w/t_w \leq 0.85(E/\sigma_y)^{1/2} C_2$$

1.5.6(d) Outstanding Face Bars and Flanges

$$d_w/t_w \leq 0.5(E/\sigma_y)^{1/2} C_2$$



where

t_w = total required thickness, in mm (in.)

d_w = depth of the web, in mm (in.)

E = as defined in 3-2-4/1.3.2

σ_y = yield strength of material, in N/mm² (kgf/mm², psi)

Note: Generally the unwelded yield strength may be used, but due account should be made for critical or extensive weld zones.

C_2 = 1 where $\sigma_a > 0.80\sigma_y$

= $0.80\sigma_y/\sigma_a$ where $\sigma_a < 0.80\sigma_y$, and σ_a is to be taken not less than $0.55\sigma_y$

For webs and flanges that do not satisfy these limits, a detailed analysis of buckling strength using an acceptable method should be submitted for review. The *ABS Guide for Buckling and Ultimate Strength Assessment for Offshore Structures* may be used for reference.

1.7 Corrugated Panels

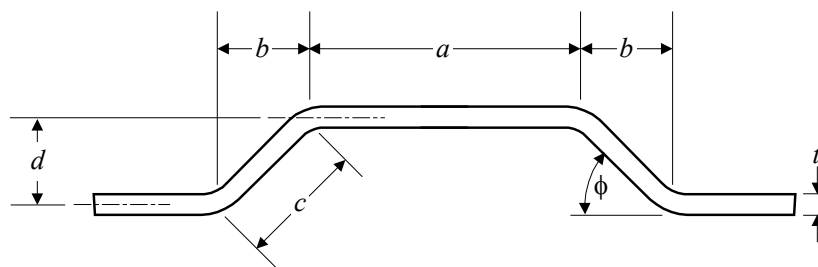
1.7.1 Stiffeners

The section modulus, SM , for corrugated bulkhead is to be not less than obtained by the requirements in 3-2-4/1.3 with ℓ being the distance between supporting members in m (ft), and s is equal to $a + b$ where a and b are as defined in 3-2-4/Figure 3 in m (ft).

$$SM = td^2/6 + (adt/2)$$

The developed section modulus, SM , may be obtained from the following equation, where a , t , and d are as indicated in 3-2-4/Figure 3.

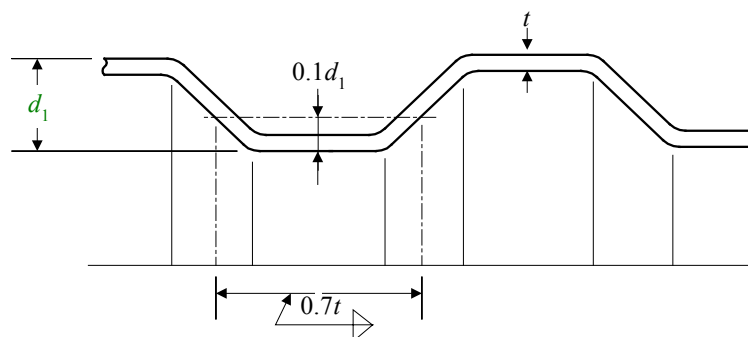
FIGURE 3
Corrugated Bulkhead



1.7.2 End Connections

The structural arrangements and size of welding at the ends of corrugations are to be designed to develop the required strength of corrugation stiffeners. Joints within 10% of the depth of corrugation from the outer surface of corrugation, d_1 , are to have double continuous welds with fillet size, w , not less than 0.7 times the thickness of the bulkhead plating or penetration welds of equal strength (3-2-4/Figure 4).

FIGURE 4
Corrugated Bulkhead End Connections



1.9 Web Thickness

The thickness of the webs of structural members is not to be less than determined by the following equation:

1.9.1 Webs

$$\frac{d_w}{t_w} = 1.54 \left(\frac{E}{\tau_y} \right)^{1/2} \quad \text{in general}$$

$$= 1.15 \left(\frac{E}{\tau_y} \right)^{1/2} \quad \text{in slamming area}$$

where

- t_w = total required thickness, in mm (in.)
- d_w = depth of the web, in mm (in.)
- τ_y = minimum shear yield strength of steel or aluminum in the unwelded condition, N/mm² (kgf/mm², psi)

The web thickness is also not to be less than the following:

$$t = \frac{1000ps\ell}{2d_w\tau_a} \quad \text{mm} \qquad t = \frac{144ps\ell}{2d_w\tau_a} \quad \text{in.}$$

where

- t = total required thickness, in mm (in.)
- p = design pressure, in kN/m² (tf/m², psi), as given in Section 3-2-2
- s = width of shell or deck supported by the member, in m (ft)
- ℓ = length of member, in m (ft)
- d_w = depth of the web, in mm (in.)
- τ_a = design shear stress, in N/mm² (kgf/mm², psi)
 = 0.5 τ_y for steel structure and 0.5 τ_{yw} for aluminum structure. For bottom primary structure 0.75 τ_y or 0.75 τ_{yw}
- τ_y = minimum shear, unwelded condition, in N/mm² (kgf/mm², psi)
- τ_{yw} = minimum shear yield strength welded condition, in N/mm² (kgf/mm², psi)

1.11 Attachments

1.11.1 Lug Attachments

The lug weld attachment of the longitudinals to the transverse webs are to have total weld throat area not less than the following equations:

$$a_w = \frac{1000ps\ell}{2\tau_a} \quad \text{mm}^2 \qquad a_w = \frac{144ps\ell}{2\tau_a} \quad \text{in}^2$$

where

- a_w = $t_w \times \ell_w$
- t_w = weld throat, in mm (in.)
- ℓ_w = total length of weld, in mm (in.)
- p = design pressure, in kN/m² (tf/m², psi), as given in Section 3-2-2

- s = width of shell or deck supported by the member, in m (ft)
 ℓ = length of member, in m (ft)
 τ_a = design shear stress, in N/mm² (kgf/mm², psi), as defined in 3-2-4/1.9.1

1.11.2 End Attachments

The welded end attachments of members, including bracket connections, are to develop the required strength of the member being attached, considering the member as fix ended.

1.13 Direct Analysis Methods

Local structure may be designed using advanced analysis techniques such as non-prismatic beam, grillage, and finite element analysis. The requirements for the use of these types of analysis techniques are in Section 3-1-3.

1.15 Decks Exposed to Vehicle Loads

All longitudinals, beams, and girders of decks that are subject to vehicle loads are to be checked under all possible combinations of these loads. The maximum allowable design stress for these members are given in 3-2-4/Table 1

1.17 Tripping Brackets and Stiffeners

Tripping brackets are to be fitted on girders and transverses at a spacing of about 3 m (10 ft). Stiffeners are to be fitted as may be required.

3 Fiber Reinforced Plastic

3.1 General

The structural arrangements and details are to be in accordance with Sections 3-2-5 and 3-2-6. Laminates may be bi-directional or uni-directional. Bonding angles or tapes are to comply with Section 3-2-5. Laminates of webs, crowns and face bars of stiffeners, transverses and girders may be bi-directional, or multi-axial. Uni-axial caps may be used in the crowns and face bars of these members. In general, the tapes bonding the members, and their secondary bonds, are to develop the strength of the member being attached.

3.3 Fiber Reinforcement

The basic laminate given in Part 2, Chapter 6, or other approved laminates of glass, aramid, or carbon fiber, in mat, woven roving, cloth, knitted fabric, or non-woven uni-directional reinforcing plies may be used. The plies are in general to be layed-up parallel to the direction of the internal. The strength of the laminate in a direction perpendicular to the direction of the internal is in general not to be less than 25% of the warp strength except for the uni-directional caps of the flange or crown of the internal members. In way of continuous longitudinal members, the required section modulus, shear area and moment of inertia of transverse members are to be maintained by the shell or deck plating and that part of the transverse member that is continuous over the longitudinal member.

Where higher strength or higher modulus plies are used in the flange or crown of the internal, it may be advisable to provide similar higher strength, higher modulus local plies in the shell or deck plating, in the direction parallel to the internal to balance the strength and stiffness of the high strength and high modulus plies in the flange or crown of the internal.

3.5 Strength and Stiffness

3.5.1 Section Modulus

The section modulus of each longitudinal, stiffener, transverse web and girder including the plating to which it is attached is to be not less than given by the following equation:

$$SM = \frac{83.3 \times ps\ell^2}{\sigma_a} \text{ cm}^3 \qquad SM = \frac{144 \times ps\ell^2}{\sigma_a} \text{ in}^3$$

where p , s , ℓ and σ_a are defined in 3-2-4/1.3.

Where the shell, deck or bulkhead plating, and the webs and flange and crown of the member are of different strength or elastic property plies, consideration is to be given to the effect of the different moduli plies in calculating the moment of inertia and section modulus; the required section modulus is to be considered for each different strength laminate of the member.

3.5.2 Moment of Inertia

The moment of inertia of each longitudinal, stiffener, transverse web, stringer or girder, including the plating to which it is attached, is to be not less than given by the following equation:

$$I = \frac{260ps\ell^3}{K_4E} \text{ cm}^4 \qquad I = \frac{54ps\ell^3}{K_4E} \text{ in}^4$$

where

- $K_4 = 0.005$ for shell and deep tank girders, stringers and transverse webs.
- $= 0.004$ for deck girders and transverses.
- $= 0.010$ for all other members.

- $E =$ tensile or compressive modulus, in N/mm² (kgf/mm², psi) representative of the basic value used in the moment of inertia calculation.

p , s and ℓ are as given in 3-2-4/1.3.

3.5.3 Shear Area

The web area, A , of the member is to be not less than given by the following equation:

$$A = \frac{1000ps\ell}{2\tau} \text{ mm}^2 \qquad A = \frac{144ps\ell}{2\tau} \text{ in}^2$$

where

- $A =$ net web area, in mm² (in²), at location being considered
- $\tau =$ design shear stress, in N/mm² (kgf/mm², psi), to be taken not greater than $0.4\tau_u$
- $\tau_u =$ lesser of ultimate shear strength, in N/mm² (kgf/mm², psi), in either warp or fill of the web laminate

p , s and ℓ are as given in 3-2-4/1.3.

Consideration will be given to determining the web area using more detailed methods of determining the shear stress in the web at the neutral axis of the member.

3.7 Proportions

The thickness of webs and flanges are to be in accordance with Section 3-2-6.

3.9 Buckling

3.9.1 Single Skin Laminate

Where single skin laminate members are subject to in-plane compressive loading likely to cause axial overall or local buckling, design calculations are to be submitted to show the margin against buckling failure.

3.9.2 Sandwich Laminates

Where sandwich laminate members are subject to in-plane compressive loading, likely to cause axial overall or local buckling of the sandwich, or of the sandwich skins, design calculations are to be submitted to show the margin against buckling failure.

3.11 Tripping Brackets and Stiffeners

Tripping brackets are to be fitted on girders and transverses at a spacing of about 3 m (10 ft). Stiffeners are to be fitted as may be required.

5 Stanchions

5.1 General

The structure under stanchions is to be of sufficient strength to distribute the loads effectively. Stanchions above are to be arranged directly over stanchions below wherever possible; where this is not possible, effective means are to be provided for transmitting the loads to the structure below. Stanchions in double bottoms and under the tops of deep tanks are to be metal and solid in cross section. Stanchions are in general not to be used in the bottom or double bottom structures where subject to high impact loads in service.

5.3 Stanchion Analysis

The load, W , on a given stanchion is to be developed from the end reaction from the girders that the stanchion supports. These end reactions are to be developed considering the design pressure for the deck in which they are located plus any point loads from stanchions located on the girder. When cascading the stanchion loads through the structure, the analysis is to consider the load from the deck directly above the stanchion plus the loads from all complete decks and one-half the load from all partial or deckhouse decks. The requirement in 3-2-4/5.5 is given for a simple stanchion that will only need to support the deck directly above. In general, stanchions are to have sectional area not less than $1.015W \text{ cm}^2$ ($0.16W \text{ in}^2$) where the stanchions are subject to tension loads.

5.5 Stanchion Load

The load on a stanchion is to be obtained from the following equation:

$$W = pbs \quad \text{kN (tf)} \qquad W = 0.064 pbs \quad \text{Ltf}$$

where

$$\begin{aligned} W &= \text{load, in kN (tf, Ltf)} \\ b &= \text{mean breadth, in m (ft), of area supported} \\ s &= \text{mean length, in m (ft), of area supported} \\ p &= \text{design pressure, in kN/m}^2 \text{ (tf/m}^2 \text{, psi), given in Section 3-2-2} \end{aligned}$$

5.7 Permissible Load

The load a stanchion may carry is to be equal to or greater than the load on the stanchion obtained in 3-2-4/5.3. This permissible load is to be obtained from the following equations:

5.7.1 Ordinary Strength Steel Stanchions

$$W_a = (12.09 - 4.44\ell/r) A \quad \text{kN}$$

$$W_a = (1.232 - 0.452\ell/r) A \quad \text{tf}$$

$$W_a = (7.83 - 0.345\ell/r) A \quad \text{Ltf}$$

Refer to 3-2-8/3.1 of the *Rules for Building and Classing Steel Vessels* for high strength steel.

5.7.2 Aluminum-Alloy Stanchions

$$W_a = (10.00 - 5.82\ell/r) A \sigma_y / 165 \quad \text{kN}$$

$$W_a = (1.02 - 0.593\ell/r) A \sigma_y / 17 \quad \text{tf}$$

$$W_a = (6.49 - 0.452\ell/r) A \sigma_y / 24000 \quad \text{Ltf}$$

where

- W_a = permissible load, in kN (tf, Ltf)
- r = least radius of gyration of stanchion, in cm (in.)
- A = area of stanchion, in cm² (in²)
- ℓ = unsupported length of stanchion, in m (ft)
- σ_y = minimum yield strength of welded aluminum under consideration, in N/mm² (kgf/m², psi)

The adoption of aluminum test values higher than given in Part 2, Chapter 5 will be subject to special consideration.

5.9 FRP Stanchions

FRP stanchions will be subject to special consideration.

5.11 Support by Bulkheads

Bulkheads supporting girders or bulkheads fitted in lieu of stanchions are to be stiffened to provide support not less effective than required for stanchions.

7 Internals Subject to Specific Payloads

A first principles analysis is to be performed for all internals that are subject to a specific payloads. The maximum stresses and deflections in these plates are not to exceed the stresses given in 3-2-4/Table 2.

TABLE 2
Maximum Stresses

		Steel	Aluminum	FRP	
				σ	δ
Human Load	Human Load	---	---	$0.33 \sigma_u$	$0.01s$
Helicopter Decks	Overall Dist. Loading	$0.60 \sigma_y$	$0.6 \sigma_{yw}$	See Note 1	See Note 1
	Landing Impact Loading Beams	σ_y	σ_{yw}	See Note 1	See Note 1
	Landing Impact Loading Girders, Stanchions, or Truss Supports ⁽²⁾	$0.9 \sigma_y$	$0.9 \sigma_{yw}$	See Note 1	See Note 1
	Stowed helicopter Loading Beams	$0.9 \sigma_y$	$0.9 \sigma_{yw}$	See Note 1	See Note 1
	Stowed helicopter Loading Girders, Stanchions, or Truss Supports ⁽²⁾	$0.8 \sigma_y$	$0.8 \sigma_{yw}$	See Note 1	See Note 1

- σ_y = yield strength of steel, in N/mm² (kgf/mm², psi)
- σ_{yw} = welded yield strength of aluminum, in N/mm² (kgf/mm², psi)
- s = panel spacing
- σ_u = ultimate tensile strength, in N/mm² (kgf/mm², psi)

Notes:

- 1 Composites will be specially considered for use in this location.
- 2 For members subjected to axial compression, the factor of safety is to be based on the yield stress or critical buckling stress, whichever is less.

CHAPTER 2 Hull Structures and Arrangements**SECTION 5 Hull Structural Arrangement****1 Structural Arrangement – All Materials****1.1 Framing, Webs, Girders, and Non-tight Structural Bulkheads****1.1.1 General**

The shell, main deck, and the sides and tops of long superstructures are in general to be longitudinally framed; depending on craft length, speed and structural stability, craft may also be transversely framed. On transversely framed craft, it is to be clearly indicated that the structure has a continuous load path that eliminates hard spots on unsupported structure.

Bulkheads, partial bulkheads or web frames are to be arranged in the main hull and in long superstructures or deckhouses to provide effective transverse rigidity. Bulkheads or deep web frames are to be provided in the main hull under the ends of superstructures or deckhouses.

Longitudinal frames are to be supported by transverse web frames, transverse bulkheads or other transverse structure. For craft over 61 m (200 ft) in length, or on craft where the longitudinal stiffeners need to be included in the offered longitudinal strength calculation to meet the requirements in 3-2-1/1, the longitudinals are to be continuous in way of transverse supporting members, including transverse bulkheads. All other craft may have longitudinal members intercostal to the transverse bulkheads provided that continuity of strength and end fixity are maintained in accordance with 3-1-2/5.9 and 3-2-5/1.1.2. Craft that are under 30.5 m (100 ft) in length, and where the longitudinal stiffeners do not need to be included in the offered longitudinal strength calculation to meet the requirements in 3-2-1/1, may have longitudinal stiffeners that are intercostal to the transverse supporting members and bulkheads providing that continuity of strength and end fixity are maintained in accordance with 3-1-2/5.9 and 3-2-5/1.1.2. With transverse framing, deck and bottom girders are to be provided. Girders may be intercostal at transverse bulkheads provided continuity of strength is maintained and end fixity is provided in accordance with 3-1-2/5.9 and 3-2-5/1.1.2.

Transverses are to be arranged as continuous web rings and girders are to be aligned with stiffeners at bulkheads. Alternative arrangements that provide fixity at the ends of transverses and girders will be specially considered.

1.1.2 Attachments and Stiffening

At supporting members, the attachment of all internal structural members is to provide end fixity and effective load transmission. Special consideration will be given to reduced end fixity where the alternative structure has equivalent strength.

The webs of all members are to be effectively attached to the shell, deck or bulkhead plating, to their supporting members and to face bars in accordance with the requirements in Section 3-2-13.

1.1.3 Engines, Machinery, and other Foundations

The foundations of engines and associated machinery are to be installed to the manufacturer's recommendations. These foundations are to be constructed to withstand the loads imparted by the equipment they support under the worst intended operating conditions. The rigidity of foundations and supporting structure shall be sufficient to prevent misalignment, deflection, or vibration, which would interfere with the operation of the equipment.

Foundations supporting waterjets will be specially considered.

Where main engine girders are part of the longitudinal strength of the craft, there is to be continuity of strength and transition to smaller longitudinal structure. The flanges of engine girders are to be tripped at each transverse frame. All changes of engine girder web depth are to be gradual. The angle of this transition is not to exceed 45°.

Foundations of auxiliary equipment are to be similar to that of engine foundations. They are to provide for secure attachment of the equipment and are to be effectively attached to the hull structure.

Crane and davit foundations are to be capable of withstanding the axial load and the maximum overturning moments specified by the crane manufacturer.

The foundations for anchor winches or windlasses are to be designed in accordance with the requirements in 3-5-1/11.3.

Structural members of all foundations are not to be punched or drilled for the attachment of equipment or fittings. Brackets, margin plates, special framing, or weld studs are to be attached to the structure and the components mounted on them and not directly on the structure.

All connections that are constructed with the use of a bi-metallic connection are to be in accordance with 3-2-6/1.1.6 and 3-2-13/3.

Consideration is to be given to the submittal of plans of the foundations for main propulsion units, reduction gears and thrust bearings and of the structure supporting those foundations to the machinery manufacturer for review.

1.3 Watertight Bulkheads

1.3.1 General

All vessels having lengths, L , equal to or exceeding 15 m (50 ft) are to be provided with watertight bulkheads in accordance with this section. The plans submitted are to clearly show the location and extent of each watertight bulkhead. Watertight bulkheads constructed in accordance with the Rules will be recorded in the *Record* as **WT** (watertight), the symbols being prefixed in each case by the number of such bulkheads.

1.3.2 Openings and Penetrations

The number of openings in watertight subdivisions is to be kept to a minimum, compatible with the design and proper working of the vessel. Where penetrations of watertight bulkheads and internal deck are necessary for access, piping, ventilation, electrical cables, etc., arrangements are to be made to maintain the watertight integrity. Relaxation in the watertightness of openings above the freeboard deck may be considered, provided it is demonstrated that any progressive flooding can be easily controlled and that the safety of the vessel is not impaired.

Ventilation penetrations through watertight subdivision bulkheads are to be avoided. Where penetrations are unavoidable, the ventilation ducting is to satisfy watertight bulkhead requirements or watertight closing appliances are to be installed at the bulkhead penetrations. For ventilation penetrations below the bulkhead deck or below damage equilibrium waterlines, the closing appliances are to be operable from the bridge. Otherwise, local, manual controls may be provided.

1.3.3 Collision Bulkhead

Craft having a length, as defined in Section 3-1-1, of or exceeding 15 m (50 ft) are to be provided with a collision bulkhead fitted not less than $0.05L_f$ abaft the stem at the design load waterline. At no point on vessels having 500 or more gross tonnage, except as specially permitted, is it to be further than $0.08L_f$ or $0.05L_f + 3$ m (9.84 ft), whichever is greater, from the reference point. The bulkheads are to be intact except for approved pipe penetrations, and are to extend to the main weather deck preferably in one plane. In craft having long superstructures at the forward end, the bulkheads are to be extended weathertight to the superstructure deck. Provided the extensions are not less than $0.05L$ abaft the stem at the design load waterline, they need not be fitted directly over the collision bulkhead. In such cases, the part of the deck forming the step is to be weathertight.

On vessels with bow-doors, that part of their sloping loading ramps that form part of the extension of a collision bulkhead and are more than 2.3 m (7.5 ft) above the freeboard deck may extend forward of the limit below.

Collision bulkhead requirements for passenger vessels are as indicated in the *ABS Guide for Building and Classing Passenger Vessels (Passenger Vessel Guide)*.

1.3.4 Reference Point

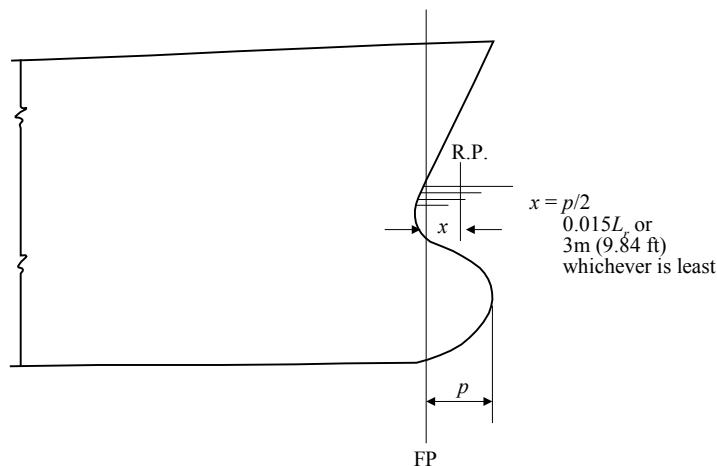
The reference point in determining the location of the collision bulkhead is the forward end of L_f except that in the case of vessels having any part of the underwater body, such as the bulbous bow, extending forward of the forward end of L_f , the required distances are to be measured from a reference point located a distance forward of the forward end of L_f . This distance, x , is the lesser of the following (see 3-2-5/Figure 1):

- i) Half the distance between the forward end of L_f and the extreme forward end of the extension, $p/2$ or
- ii) $0.015L_f$
- iii) 3 m (9.84 ft)

where L_f is as defined in 3-1-1/3.3.

The forward end of L_f is to coincide with the fore side of the stem on the waterline at which L_f is measured.

FIGURE 1
Reference Point of Vessels with Bulbous Bow



1.3.5 Engine Room

The engine room is to be enclosed by watertight bulkheads extending to the main weather deck.

1.3.6 Chain Locker

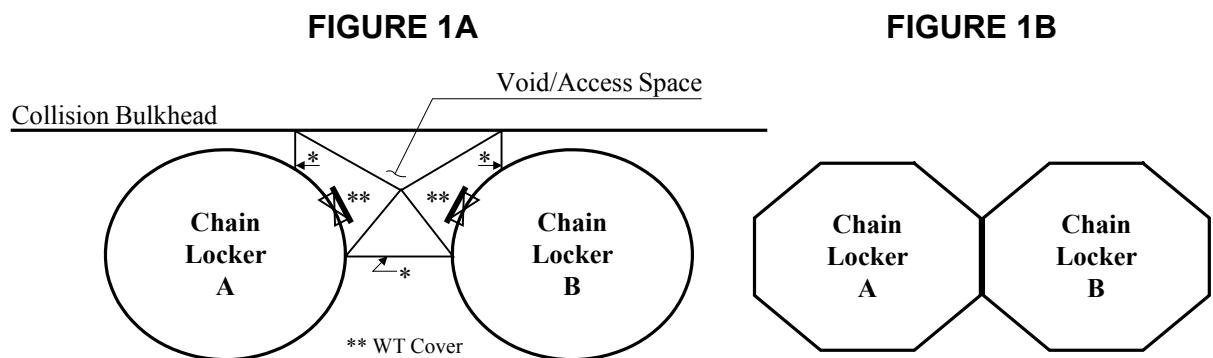
For craft with length L (as defined in 3-1-1/3) greater than 24 meters (79 feet), chain lockers and chain pipes are to be made watertight up to the weather deck. The arrangements are to be such that accidental flooding of the chain locker cannot result in damage to auxiliaries or equipment necessary for the proper operation of the craft nor in successive flooding into other spaces. Bulkheads between separate chain lockers not forming a part of subdivision bulkhead (see 3-2-5/Figure 1A below), or bulkheads which form a common boundary of chain lockers (see 3-2-5/Figure 1B below), need not be watertight.

Where means of access into chain lockers are provided, they are to be closed by a substantial cover secured by closely spaced bolts. Doors are not permitted.

Where a means of access to chain lockers is located below the weather deck, the access cover and its securing arrangements are to be in accordance with recognized standards (such as ISO 5894-1999) or equivalent for watertight manholes covers. Butterfly nuts and/or hinged bolts are prohibited as the securing mechanism for the access cover.

For closure of chain pipes, see 3-2-9/23.7.

The arrangements on craft that are not subject to the International Convention on Load Lines or its Protocol may be specially considered.



1.5 Tanks

The arrangements of all integral or independent tank structures, their intended service, and the heights of the overflow pipes are to be indicated clearly on the drawings submitted for approval. As a minimum, all gravity fill integral or independent tank structures shall meet the design criteria for plating and internals in Sections 3-2-3 and 3-2-4 considering the maximum head pressure imposed on the peripheries.

Where potable water tanks are fitted, water closets are not to be installed on top of the tanks nor are soil lines to run over the tops of the tanks. Pipes containing non-potable liquids are not to be run through the tanks. Attention is directed to the regulations of national authorities that might govern the location, construction or design of such tanks.

Baffle or swash plates are to be provided. Special consideration may be given for the omission of baffle or swash plates providing the effects of fluid slamming on the plate are considered.

Scantlings of pressurized tanks will be subject to special consideration.

All tanks and void spaces are to be accessible for inspection and repair.

1.7 Decks

Where a deck is stepped or has a break, suitable scarphing or brackets are to be provided at the side shell.

Decks passing into superstructures within the 0.5L amidships are to be increased in way of the break. See 3-2-1/1.7.4.

1.9 Means of Escape

All main hull spaces are to have two means of escape to the main weather deck. These escapes are to be located as far apart as practicable and are to be operable from both sides. All escape routes are to be readily accessible and unobstructed.

1.11 Double Bottoms

1.11.1 General

Inner bottoms are to be fitted fore and aft between the peaks or as near thereto as practicable in vessels of ordinary design of 500 GT or over. Where, for special reasons, it may be desired to omit the inner bottom, the arrangements are to be clearly indicated on the plans when first submitted for approval. A double bottom need not be fitted in way of deep tanks, provided the safety of the vessel in the event of bottom damage is not thereby impaired. It is recommended that the inner bottom be arranged to protect the bilges as much as possible and that it be extended to the sides of the vessel.

Shell longitudinals and frames in way of deep tanks are to have not less strength than is required for stiffeners on deep tank bulkheads.

1.11.2 Passenger Craft

For passenger craft that are on international voyages that operate more than four hours at operational speed from a port of refuge are to be fitted with double bottoms in accordance with the *Passenger Vessel Guide*.

1.11.3 Cargo Craft

Cargo craft that are on international voyages that are more than eight hours at operational speed from a port of refuge are to be fitted with double bottoms. The inner bottoms are to be fitted fore and aft between the peaks or as near thereto as practicable. Where, for special reasons in design, it may be desired to omit the double bottom, the arrangement are to be clearly indicated on the plans when first submitted for approval. A double bottom need not be fitted in way of deep tanks provided the safety of the ship in the event of bottom damage is not thereby impaired. It is recommended that the inner bottom be arranged to protect the bilges as much as possible and that it be extended to the sides of the craft. The scantlings of the double bottom are to be fitted in accordance with Sections 3-2-2, 3-2-3, and 3-2-4.

1.13 Doors, Hatches, Scuttles, and Manhole Covers

All doors, hatches, scuttles, and manhole covers, together with their frames and coamings, are to be in accordance with the same requirements as the structure in which they are installed.

1.15 Helicopter Decks

1.15.1 General

Helicopter landing facilities, where provided, are to meet the following structural and safety requirements. The attention of owners, builders and designers is directed to various international and governmental regulations and guides regarding the operational and other design requirements for helicopter landing on craft. See also 4-6-4/3.9.2, and 4-6-7/9 of the *Steel Vessel Rules*.

Plans showing the arrangement of the helicopter deck are to be submitted. The arrangement plan is to show the overall size of the helicopter deck and the designated landing area. If the arrangement provides for the securing of a helicopter or helicopters to the deck, the predetermined position(s) selected to accommodate the secured helicopter, in addition to the locations of deck fittings for securing the helicopter, are to be shown. The type of helicopter to be considered is to be specified and calculations for appropriate loading conditions are to be submitted.

1.15.2 Safety Net

The unprotected perimeter of the helicopter landing deck is to be provided with safety netting or equivalent.

1.15.3 Material

In general, the construction of helicopter decks is to be of steel or other material with equivalent ability to retain structural capacity in a fire. If the helicopter deck forms the deckhead of a deckhouse or superstructure, it is to be insulated to A-60 class standard.

Aluminum alloys may be used for helicopter decks integral if they form part of an aluminum deckhouse or superstructure. They may also be of aluminum alloy, fitted above a steel deckhouse or deck structure, provided the following conditions are complied with:

- i) There are to be no openings in the exterior bulkheads directly below the helicopter deck.
- ii) All windows in the lower exterior bulkheads are to be fitted with steel shutters.

1.15.4 Means of Escape and Access

The helicopter deck is to be provided with both a main and an emergency means of escape and access for fire fighting and rescue personnel. These means are to be located as far apart from each other as is practicable and preferably on opposite sides of the helicopter deck.

1.17 Compensation

Compensation is to be provided for openings in the shell plating where required to maintain the longitudinal and transverse strength of the hull. All openings are to have well-founded corners. Those in the upper side shell are to be located a suitable distance below the deck edge. Cargo and gangway openings are to be kept well clear of other discontinuities in the hull girder. Local provision is to be made to maintain the longitudinal and transverse strength of the hull.

Thick plating and doublers of sufficient breadth to prevent damage from the flukes of stockless anchors are to be fitted around the hawse pipes.

3 Structural Arrangements – Additional Requirements for Steel and Aluminum Alloys

3.1 Shell Plating

The bottom shell plating is to extend to the chine or upper turn of bilge. In general, the side shell is to be of the same thickness from its lower limit to the gunwale. Increases in thickness and additional stiffening are required in way of skegs, shaft struts, hawse pipes etc. Where a bow thruster tube is fitted to be in accordance with the requirements in 3-2-3/1.7.

5 Structural Arrangements – Additional Requirements for Fiber Reinforced Plastic Hulls

5.1 Tanks

In fiber reinforced plastic construction, non-integral tanks are to be used whenever possible. When integral tanks are used they are to be of single skin construction; the only exception is the tank top plating can be of sandwich construction. No stiffeners within integral tanks are to penetrate the tank boundaries. No gasoline tanks, or tanks containing petroleum products with flash points less than 60°C (150°F) are to be fitted integrally. The design and arrangements of oil fuel tanks is to be such that there is no exposed horizontal section at the bottom that could be exposed to a fire. Other fire protection arrangements for oil fuel tanks will be specially considered. For details of fire protection requirements see Section 3-4-1.

All internal surfaces of FRP tanks are to be covered with chopped strand mat weighing at least 600 g/m² (2 oz/ft²). This covering is to be in addition to the scantlings required by this Guide. A suitable coating is to be applied to this covering to prevent the contents of the tank from impregnating the surrounding laminates. The sides, tops, and baffles of integral tanks are to have all connections taped on both sides. Fresh water tanks are to be coated with a non-toxic and non-tainting coat of resin that is recommended by the resin manufacturer for potable water tanks. Where outfit items are to be laminated to the tank surface, the heavy coating of resin is to be applied afterwards and the laminated brackets sealed to prevent the ingress of moisture. The scantlings of integral oil fuel and water tanks are to be in accordance with Sections 3-2-3 and 3-2-4. Integral tanks are to be tested in accordance with 3-7-1/Table 1.

CHAPTER **2 Hull Structures and Arrangements**SECTION **6 Arrangement, Structural Details, and Connections****1 Structural Details****1.1 Aluminum and Steel**

1.1.1 General

Structural details are to be designed and constructed to minimize hard spots, notches and other structural discontinuities. Openings in webs, girders and other structural internal members are to be arranged clear of concentrated loads or areas of high stresses; slots in transverses and girders for longitudinals or beams in such locations are to be fitted with collars. Care is to be taken to ensure structural continuity; sharp corners and abrupt changes in section are to be avoided; toes of brackets and ends of members are not to terminate on plating without attachment to an adjacent member, unless specially approved.

1.1.2 Longitudinals

Deck, bottom and inner bottom longitudinals are in general to be continuous unless specially approved otherwise, but in way of bulkheads they may be intercostal provided continuity of strength and end fixity are maintained by the end brackets. The ends of all internal structural members are to provide end-fixity and load transmission to the supporting member. Departures from this may be considered where the alternative structure has equivalent strength. See 3-2-5/1

1.1.3 Girders and Transverses

Girders and transverses are to have depths not less than twice the depth of slots for longitudinals and beams or other openings. Transverses are to be arranged as continuous web rings, girders are to be aligned with stiffeners at bulkheads, alternative arrangements that provide fixity at the ends of transverses and girders will be specially considered.

1.1.4 Openings

Access and lightening holes with suitably radiused corners are to be arranged as necessary and clear of areas of load concentration or high stresses. Their depths and lengths are generally not to exceed respectively, 0.5 and 0.75 the depth of the members.

1.1.5 Limber Holes

Drains or limber holes are to be provided in non-tight structure to prevent the accumulation of liquids. Vent pipes are to be arranged to prevent over pressuring of tanks. (See 4-4-3/9.1) Holes are to be located to ensure complete drainage of all non-tight voids, bays, or pockets formed by structure. The holes are not to be located at points of high stress, such as the intersection of members. Limber holes are to be half round at the edge, or round if not at the edge, of the structure that is to be drained. The diameter of drain or limber hole is not to be greater than 20% of the depth of the member.

1.1.6 Bi-metallic Connections

In aluminum construction, where bi-metallic connections are unavoidable, suitable insulation, such as gaskets, washers, sleeves, and bushings, are to be provided. The faying surfaces between mechanically fastened metal components, except machinery foundation shims, are to be protected by the use of a bedding compound. Stainless steel fasteners may be joined directly. See also 3-2-13/3.

1.3 Fiber Reinforced Plastic

1.3.1 General

Structural continuity is to be maintained and where changes in thickness or structural section occur, they are to be gradual to prevent notches, hard spots and other structural discontinuities. The requirements of 3-2-6/1.3.4 and 3-2-6/1.3.5, below, and of 3-2-6/3 and 3-2-6/5 are for the basic laminate given in Part 2, Chapter 6. Special consideration will be given where other laminates or resins are used. The ends of all internal structural members are to provide end-fixity and load transmission to the supporting member. Departures from this may be considered where the alternative structure has equivalent strength.

1.3.2 Changes in Laminate Thickness

A gradual taper is to be used for all changes in laminate thickness. Where the construction changes from sandwich laminate to a solid laminate, the thickness of the core material is in general, to be reduced by a gradual taper of not less than 2:1.

1.3.3 Openings, Holes and Raw Edges

Access and lightening holes with suitably radiused corners are to be arranged as necessary and clear of areas of load concentration or high stresses. Their depths and lengths are generally not to exceed, respectively, 0.5 and 0.75 times the depths of the members. Air and limber holes are to be in accordance with 3-2-6/1.1.5.

All exposed edges in way of cuts or holes in FRP single-skin laminates are to be sealed with resin. Edges of sandwich panels and edges of holes in sandwich panels are to be covered with one ply of glass cloth lapped no less than 25 mm (1 in.) onto each face of the laminate. The cloth shall be completely saturated with resin.

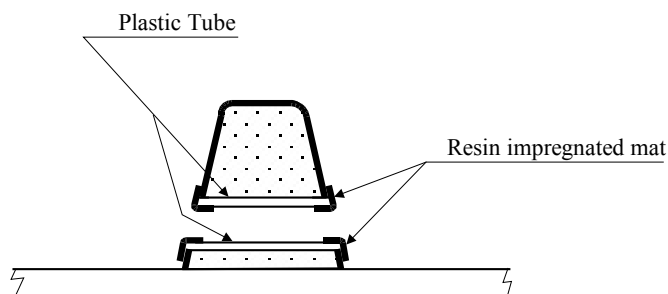
Ferrules installed in sandwich panels or stiffeners for drains or wire penetrations are to be set in bedding compound.

All hatch openings are to be supported by a system of transverse and longitudinal stiffeners.

1.3.4 Piping and Wiring in Foam

Piping or wiring passing through foam-filled spaces is to be installed in PVC tubing. The pipe is to be arranged such that water will not become trapped. The ends of the plastic tubing are to be joined to adjacent structure with resin impregnated mat. See 3-2-6/Figure 1.

FIGURE 1
Piping or Opening through Foam Filled Space



1.3.5 Stiffeners

1.3.5(a) General. Stiffeners, frames, girders, deck beams, bulkhead stiffeners, etc. used to support FRP panels may be entirely of FRP, FRP laid over nonstructural cores or forms, or composites of FRP or other approved structural materials.

1.3.5(b) *Stiffeners without effective Cores or with Nonstructural Cores.* Stiffeners without cores or with cores not indicated in 2-6-1/Table 1 are to conform to 3-2-6/Figure 2, and the thickness of the crown and web of the stiffeners is to be not less than obtained from the following equations:

$$t_1 = w/20 \text{ mm (in.)} \qquad t = h/30 \text{ mm (in.)}$$

where

- t_1 = thickness of stiffener crown, in mm (in.)
- t = thickness of stiffener webs, in mm (in.)
- w = width of stiffener crown, in mm (in.)
- h = height of stiffener webs, in mm (in.)

Where the stiffeners are of laminates with properties differing from the basic laminate, the thickness is to be modified by the factor:

$$7.7 \sqrt{\frac{C}{E}}$$

where

- E = compressive modulus of proposed laminate, in kg/cm² (psi)
- C = ultimate compressive strength of proposed laminate, in kg/cm² (psi)

Where polyvinylchloride, balsa, or other approved core material is used, thicknesses less than given above may be accepted provided the buckling stresses of the stiffener skins comply with the buckling stress criteria in 3-2-3/5.7.4.

Hat-section stiffeners constructed by laying FRP over premolded FRP forms (3-2-6/Figure 3) are to conform with 3-2-6/Figure 2 and the above equations; the premolded forms may be considered structurally effective if their physical properties are at least equal to those of the overlay laminates.

FIGURE 2
Proportions of Stiffeners

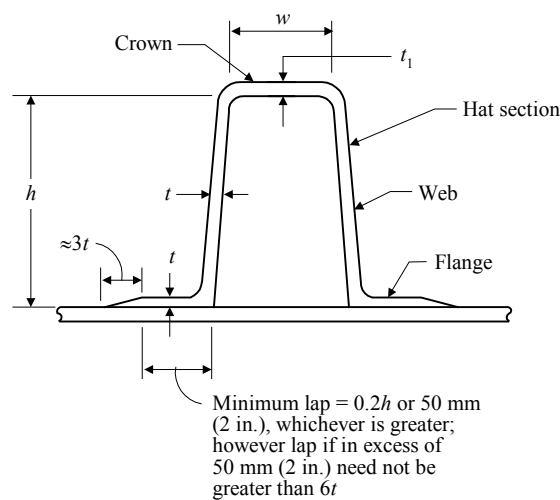
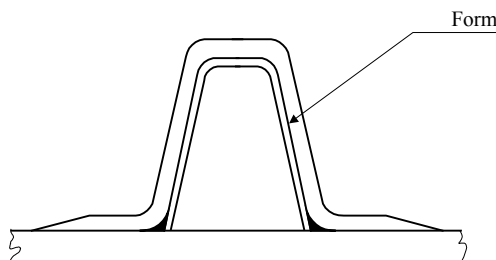


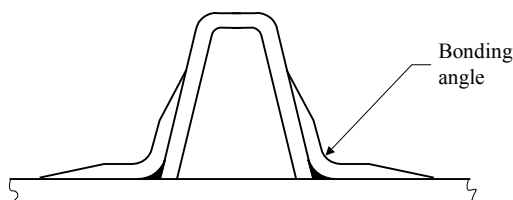
FIGURE 3
Premolded FRP Form



Premolded stiffeners bonded to the laminates with FRP angles, flanges or tapes (3-2-6/Figure 4) are also to conform to 3-2-6/Figure 2 and the above equations. The thickness of each bonding angle flange or tape is to be not less than the thickness of the webs of the stiffener, and the legs of the bonding angle, flange or tape are to be of equal length in accordance with 3-2-6/5. Joints in premolded stiffeners are to be scarphed and spliced or otherwise reinforced to maintain the fill strength of the stiffeners.

The thickness may be less than obtained from the above equation if these members are suitably stiffened and provided with adequate lateral stability. The required minimum flange or tape laps onto such members, as shown in 3-2-6/Figure 2, if greater than 50 mm (2 in.), need not exceed $10t$.

FIGURE 4
Premolded Stiffener

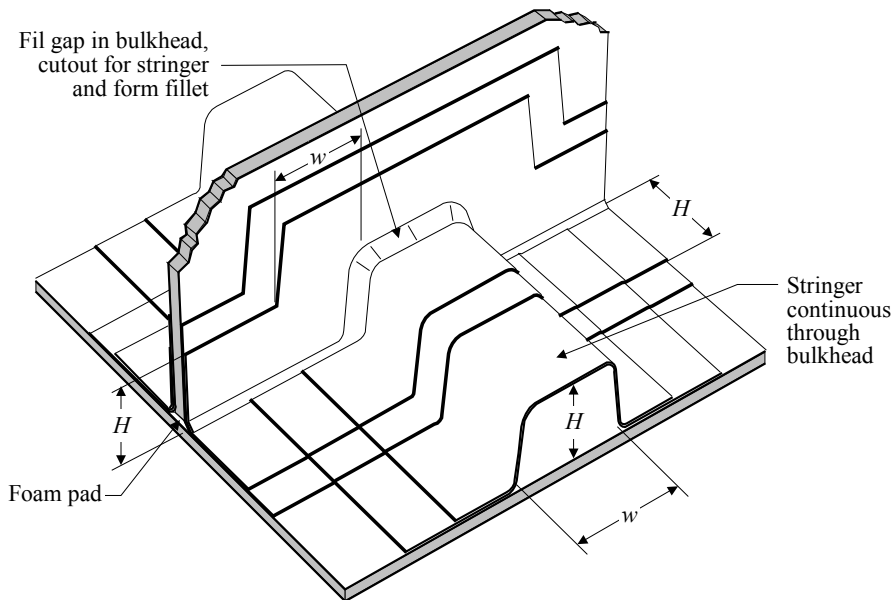


1.3.6 Girders and Longitudinal Frames

Girders and longitudinal frames are to be continuous through floors and web frames. Except in way of integral-tank end bulkheads, girders and longitudinal frames are also to be continuous through transverse bulkheads. Where such members are intercostal, attention is to be given to minimizing structural discontinuities. Where transverse structure is cut out in way of continuous members, the cut out is to be closed as to maintain the required tightness.

An acceptable type of continuous girder and longitudinal-frame FRP connection is shown in 3-2-6/Figure 5. The laps of the connections onto the supporting structure are to be not less than the overall widths of the structural members including flanges, and the thicknesses of the connections are to be not less than the thicknesses of the structural-member flanges or tapes.

FIGURE 5
Connection of Longitudinals to Transverses



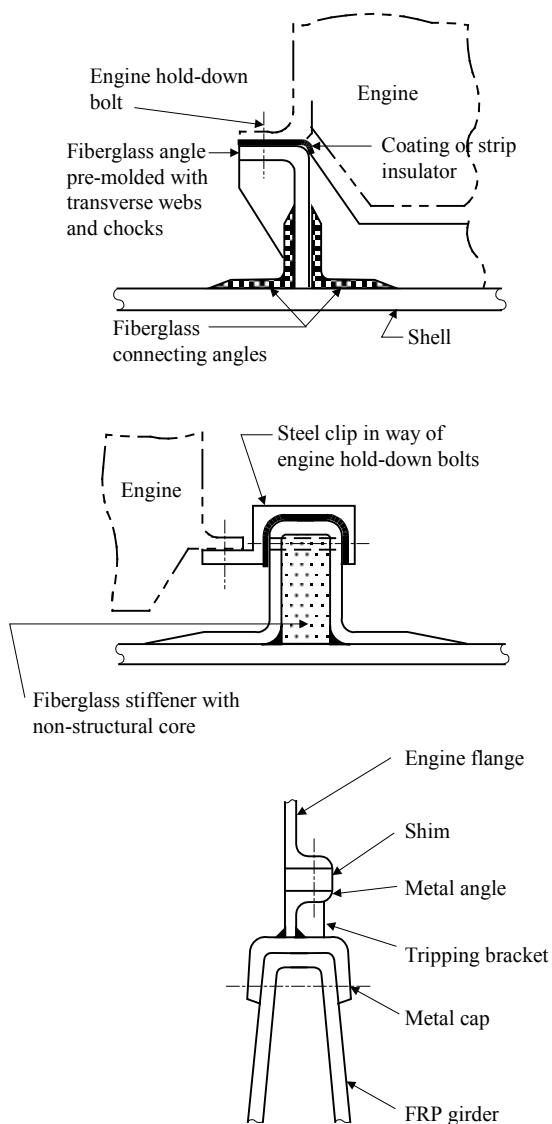
1.3.7 Engine Foundations

Engine bed fittings are to be of thicknesses and widths appropriate to the holding down bolts such that there is a close and accurate fit between the fittings and the engine girder.

Where the engine girders are a non-molded surface, the fittings are to be set in filled resin or mat. On a molded surface where the contours on the girders match the contours on the fitting, the fittings are to be set in a structural adhesive or a filled resin.

The fittings are to be bolted through the webs of the girders. A compression sleeve constructed of stainless steel or FRP is to be fitted in way of the through bolts. The area of the girder that is connected to the fitting is to have a high density insert in way of the faying surfaces. The insert is to extend 25 mm (1 in.) in all directions beyond the connection. If the size of the insert is less than 150 cm² (24 in²) a compound consisting of three parts phenolic or glass microballons, two parts resin, and one part milled glass fibers, by volume, may be used. A doubler consisting of one ply of mat and two plies of structural laminates are to be added to each face of the cored laminate. The doubler shall extend no less than 75 mm (3 in.) beyond the high density foam insert.

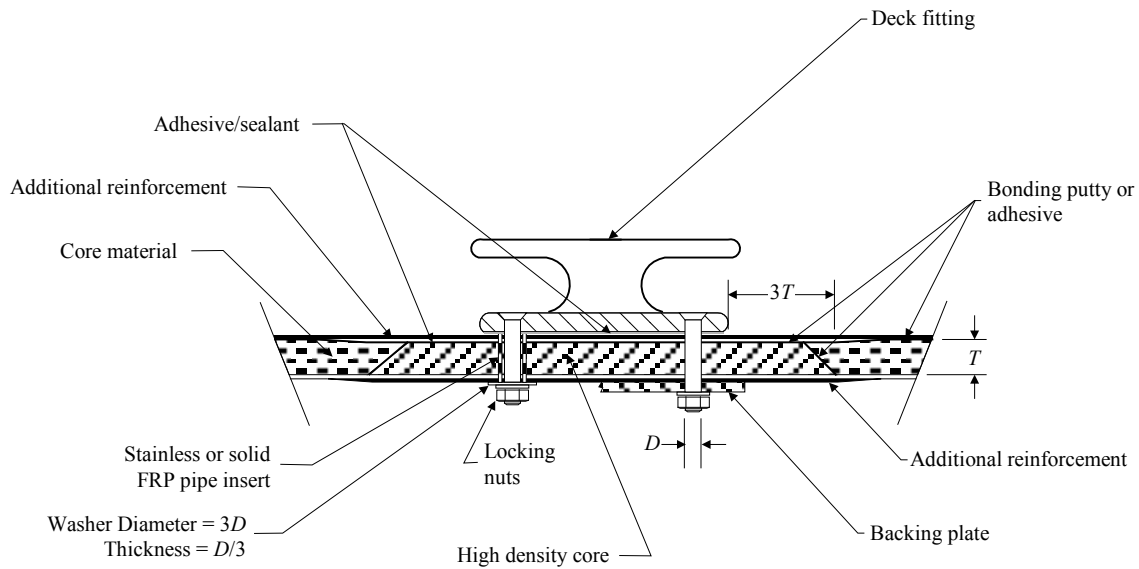
FIGURE 6
Engine Foundations



1.3.8 Deck Fittings

Deck fittings, such as cleats and chocks, are to be bedded in sealing compound, structural adhesive, or gasketed, through-bolted, and supported by either oversize washers or metal, plywood or wood backing plates, as shown in 3-2-6/Figure 7. Where washers are used, the laminate in way of the fittings is to be increased at least 25% in thickness. In no case shall the fitting impair the strength or tightness of the structure.

**FIGURE 7
 Deck Fittings**



1.3.9 Through Hull Penetrations

Generally all through hull penetrations below the deepest draft design waterline are to be formed by solid FRP laminates, as shown in 3-2-6/Figure 8. When sandwich construction is used for the hull, the core material is to be completely sealed off from the through hull penetration, as shown in 3-2-6/Figure 9. All through hull penetrations are to be taped on both sides of the penetration. The penetration is to be set in a bedding compound.

**FIGURE 8
 Through Hull Penetration – Solid Laminate**

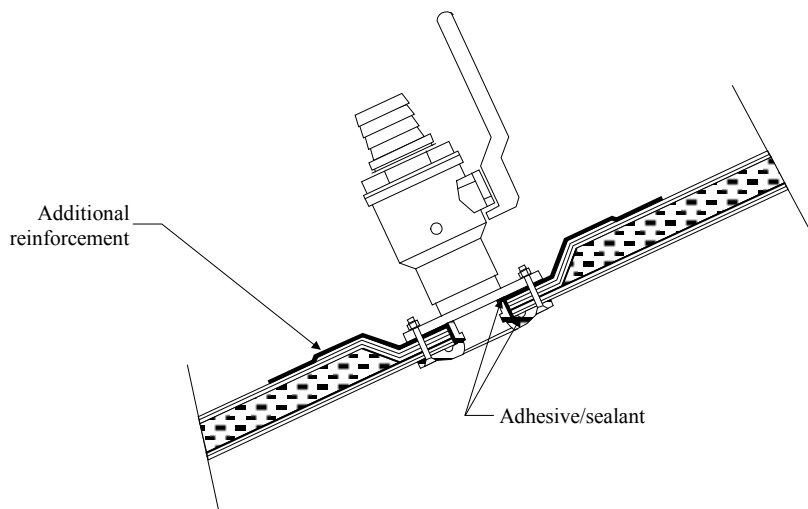
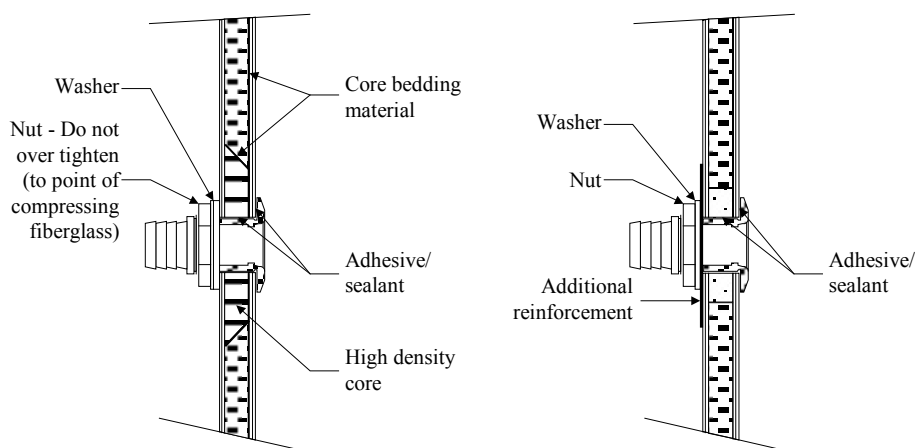


FIGURE 9
Through Hull Penetration – Sandwich Laminate



1.3.10 Boundary Angles, Flanges or Tapes

1.3.10(a) *FRP to FRP*. Secondary bonding of FRP components by means of double boundary angles, flanges or tapes is to be in accordance with Part 2, Chapter 6. Typical boundary angles for FRP components are shown in 3-2-6/Figure 10. At the end connections of sandwich laminates, the core shear strength is to be effectively developed. The bulkheads are to be set into a foam insert, slow curing polyester putty, a microballon mixture or other approved material. The thickness of each boundary angle, flange or tape having similar strength to the members being connected is to be not less than obtained from the following:

1.3.10(b) *Single-skin to Single-skin*. One-half the thickness of the thinner of the two laminates being joined.

1.3.10(c) *Sandwich to Sandwich*. The greater of the mean thicknesses of the skins of the sandwich panels being attached.

1.3.10(d) *Sandwich to Single Skin*. Either one-half the thickness of the single-skin laminate or the mean thickness of the skins of the sandwich panel being attached, whichever is less.

The thickness of each FRP-to-FRP boundary angle also is to be not less than obtained from the following equation:

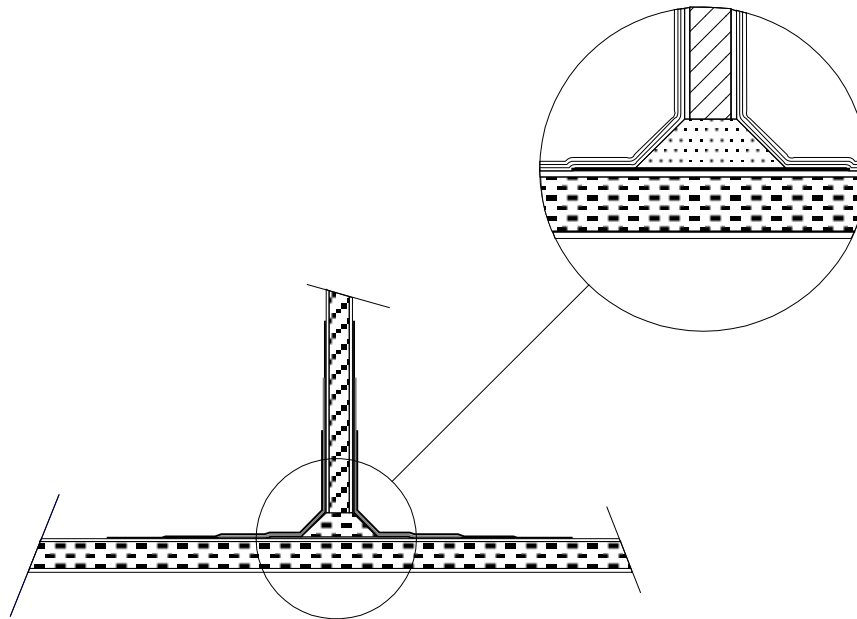
$$t = 0.105L + 1.11 \text{ mm} \qquad t = 0.00133L + 0.044 \text{ in.}$$

where

$$L = \text{length, in m (ft), as defined in 3-1-1/3, need not be taken as more than 46.6 m (153 ft).}$$

The width of each flange, not including end taper, is to be not less than 10 times the thickness given above, including the end taper, 13 times the thickness given above, and in general not less than 50 mm (2 in.).

FIGURE 10
Boundary Angles for FRP Components



3 Welded and Mechanical Connections

3.1 Steel and Aluminum

3.1.1 General

Components may be fastened by either welding or rivets. For welding, see Section 3-2-13 and Part 2, Chapters 4 and 5.

3.1.2 Expanding Rivets

Rivets of the expanding type (blind or “pop” rivets) may be used for lightly loaded connections where lack of accessibility prohibits the use of through fastenings. Such rivets are not to be used for joining components having a total thickness exceeding 12.5 mm (0.50 in.), and are not to be used for joining decks to hulls except as temporary or unstressed fastenings installed for the sake of convenience or speed during assembly.

3.1.3 Conventional Rivets

Conventional rivets, where used, are to be subject to special consideration, and are to be of the cold-driven type. Washers, essentially of the same material as the rivets, are to be installed under both the heads and the points.

3.3 Fiber Reinforced Plastic

3.3.1 General

Components may be fastened with bolts, machine screws, or self-tapping screws. Where machine screws or self-tapping screws are used, they are not to have countersunk heads. Shanks of all threaded fastenings are to be long enough to pass through the joints, by at least one thread beyond the top of the nut or plastic locking element. Excessive protrusion shall be avoided, and where the threaded end of the fastener is accessible, and the excess length can constitute a hazard, the excess length is to be removed. Washers are not to be used for the sole purpose of lessening thread protrusion. When it is necessary to reduce the length of thread protrusion, excess length is to be removed without damaging the threads and the bolts dressed to remove rough edges. Where watertight joints are required, suitable sealants or bedding compounds are to be used in addition to the fastenings. All threaded fasteners are to be stainless steel. Sizes and specifications are to be

indicated on the submitted plans. The diameter of a fastening is not to be less than the thickness of the thinner component being fastened, with a minimum diameter of 8 mm (0.315 in.). Where hardware is predrilled for fastener sizes that are less than specified above, the size of the fastener used is to match the size of the predrilled holes.

3.3.2 Bolts and Machine Screws

Bolts or machine screws are to be used where accessibility permits. The diameter of each fastener is to be at least equal to the thickness of the thinner component being fastened. Bolts and machine screws less than 8 mm (0.315 in.) in diameter are not to be used. Where d is the fastener diameter, fastener centers are to be spaced at a minimum of $3d$ apart and are to be set in from edges of laminates a minimum of $3d$.

Generally in fiber reinforced plastic construction, all bolted connections are to be made through solid fiber reinforced plastic inserts. Where this is not possible, all low density core material is to be replaced with a structurally effective insert. Diameters of fastening holes are not to exceed fastening diameters by more than 0.5 mm (0.02 in.) for bolts less than or equal to 18 mm (0.71 in.) in diameter and 1 mm (0.39 in.) for bolts greater than 18 mm (0.71 in.) in diameter. Elongated and oversize holes are permitted where necessary for adjustment or alignment.

Washers or backing plates are to be installed under all fastening heads and nuts that otherwise would bear on laminates. Washers are to measure not less than $2.25d$ in outside diameter and $0.1d$ in thickness. Nuts are to be either of the self-locking type, or other effective means are to be provided to prevent backing off. Mechanical thread locking devices and methods such as lockwashers, either spring, tooth, or tab type, peening wiring, or thread upset after assembly are not to be used.

Bolted connections are, in general, to be bonded along all mating surfaces to insure the tightness of the structure using an accepted structural adhesive, applied in accordance with the manufacturer's requirements.

In general, all structural, bolted connections are to use threads of bolts in accordance with the requirements in the following table:

<i>Location</i>	<i>Pitch ⁽¹⁾</i>
Watertight connections below design waterline	$10d$
Connections in hull above design waterline to deck	$15d$
Hull to deck connections, bonded with approved structural adhesive	$15d$
Connections in deckhouses	$20d$
Deckhouse to deck connection, bonded with approved structural adhesive	$15d$
Minimum distance between reeled lines of bolts	$3d$

Notes:

- 1 d is the diameter of the bolt.
- 2 Internal boundary sealing angle is to be provided for all locations.

All structural, single line, bolted connections without adhesive bonding are to be in accordance with the requirements in the following table:

<i>Location</i>	<i>Pitch ⁽¹⁾</i>
Manhole covers to fuel tanks	$6d$
Manhole covers to water tanks	$8d$
Covers to void tanks/cofferdams	$10d$
Bolted access hatches in decks	$10d$
Bolted watertight door frames	$8d$
Window frames	$8d$

Note: 1 d is the diameter of the bolt.

Bolt holes are to be drilled, without undue pressure at breakthrough, having a diametric tolerance of two percent of the bolt diameter. Where bolted connections are to be made watertight, the hole is to be sealed with resin and allowed to cure before the bolt is inserted. In areas of high stress or where unusual bolting configurations, on the basis of equivalence with the above requirements, are proposed, testing may be required.

3.3.3 Self-tapping Screws

In general, no self-tapping screws are to be used in fiber reinforced plastic construction. Self-tapping screws having straight shanks may be used for non-structural connections where lack of accessibility prohibits the use of through fastenings. Where used, self-tapping screws are to have coarse threads.

3.5 Backing Bars and Tapping Plates

The requirements for backing plates and bars will be individually considered, on the basis of the loading imposed, details of which are to be indicated on the submitted plans. Metal plates and bars are to be suitably protected against corrosion. Tapping plates may be encapsulated within the laminate, laminated to or bolted to the structure. Tapping plate edges or corners are to be suitably rounded.

5 FRP Deck-to-Hull Joints

5.1 Weather Joints

The connection is to develop the strength of the deck and shell laminate, whichever is stronger, by either a bolted or bonded connection.

Where flanges are used, the hull flanges are to be equal in thickness and strength to the hull laminates and the deck flanges are to be equal in strength and thickness to the deck laminates. Where bolts are used to develop the required strength of the connection, the faying surfaces are to be set in bedding compound, polyester putty, or other approved material. Minimum widths of overlaps, minimum bolt diameters, and maximum bolt spacing are to be in accordance with 3-2-6/Table 1. Intermediate values may be obtained by interpolation.

FRP bonding angles, where used, are to have flanges of the same strength and of at least one-half the thickness of single skin hull or deck laminate. On sandwich laminates, they are to have the same strength and thickness as the skin of a sandwich laminate, based on the thicker of the two laminates being connected. The widths of the flanges are to be in accordance with the widths of overlaps in 3-2-6/Table 1.

Calculations supporting the geometry of the deck-to-hull joint are to be submitted for craft over 60 m (200 ft) in length.

Each joint is to be protected by a guard, molding, fender, or rail cap of metal, wood, rubber, plastic, or other approved material. The size and ruggedness of this protective strip are to be consistent with the severity of the service for which the craft is intended. The strip is to be installed in such a manner that it may be removed for repair or replacement without endangering the integrity of the deck-to-hull joint.

5.3 Interior Joints

Interior decks are to be connected to the hull by shelves, stringers, or other structural members on both sides by FRP tapes. The connection is to effectively develop the strength of the interior deck. The fit-up between the parts are typically not to exceed 5 mm (0.2 in.). The interior deck is to be bedded in syntactic foam or filled resin during assembly and prior to tabbing.

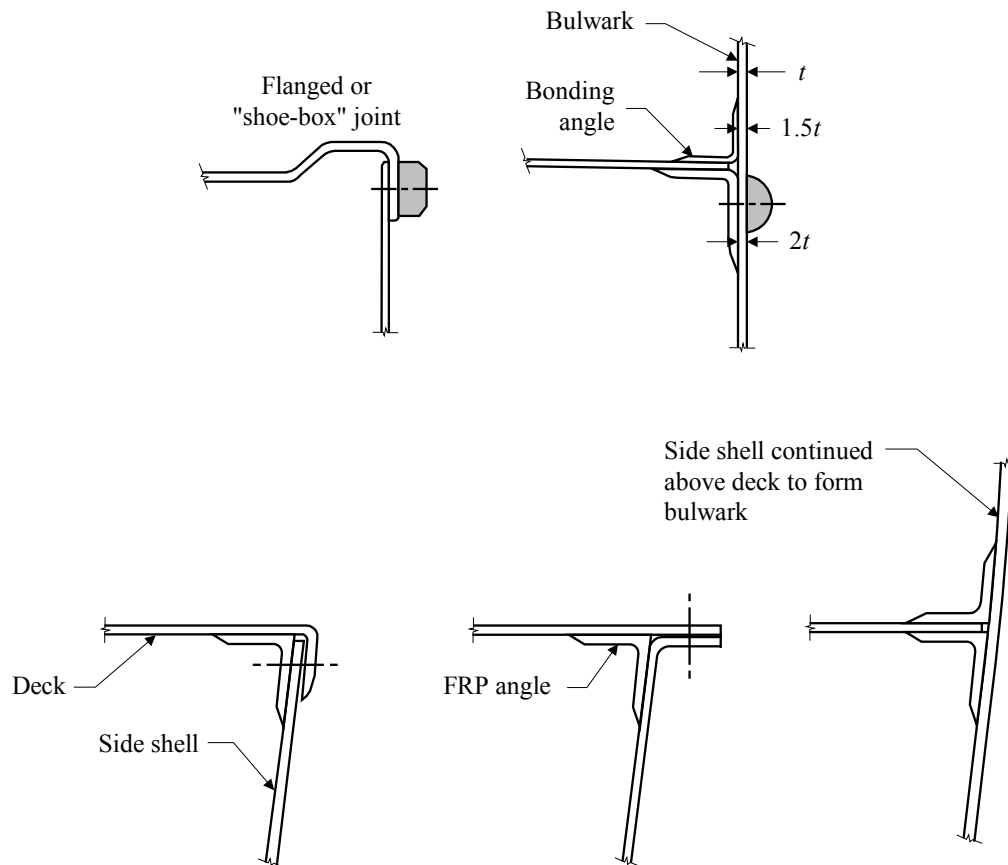
TABLE 1
Deck-to-Hull Joints
SI and MKS Units

<i>Length of Craft L, m</i>	<i>Minimum Width of Overlap, mm</i>	<i>Minimum Bolt Diameter, mm</i>	<i>Bolt Spacing, mm</i>
9	63.5	6.50	155
12	75.0	7.75	165
15	87.5	9.00	180
18	100.0	10.25	190
21	112.5	11.50	205
24	125.0	12.75	215
27	137.5	14.00	230
30	150.0	15.25	240
33	162.5	16.50	255
36	175.0	17.75	265
39	187.5	19.00	280
42	200.0	20.25	295
45	212.5	21.50	310
48	225.0	22.75	325
51	237.5	23.00	340
54	250.0	24.25	355
57	262.5	25.50	370
60	275.0	26.75	385

US Units

<i>Length of Craft L, ft</i>	<i>Minimum Width of Overlap, in.</i>	<i>Minimum Bolt Diameter, in.</i>	<i>Bolt Spacing, in.</i>
30	2.5	0.25	6.0
40	3.0	0.30	6.5
50	3.5	0.35	7.0
60	4.0	0.40	7.5
70	4.5	0.45	8.0
80	5.0	0.50	8.5
90	5.5	0.55	9.0
100	6.0	0.60	9.5
110	6.5	0.65	10.0
120	7.0	0.70	10.5
130	7.5	0.75	11.0
140	8.0	0.80	11.5
150	8.5	0.85	12.0
160	9.0	0.90	12.5
170	9.5	0.95	13.0
180	10.0	1.00	13.5
190	10.5	1.05	14.0
200	11.0	1.10	14.5

FIGURE 11
Examples of Deck-to-Hull Weather Joints



7 FRP Shell Details

7.1 Keels

Plate keels are to be not less than shown in 3-2-6/Figure 12a and 3-2-6/Figure 12b, and vertical keels or skegs are to be not less than shown in 3-2-6/Figure 13. Keels or skegs are to be adequate for docking loads, which are to be provided by the designer.

FIGURE 12a
Plate Keel in One-piece Hull

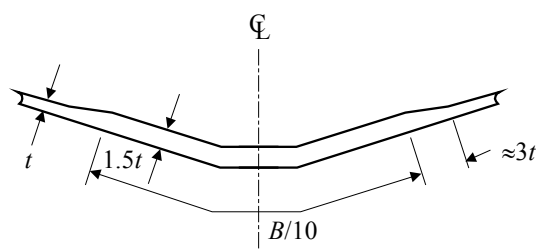


FIGURE 12b
Plate Keel in Hull Molded in Halves

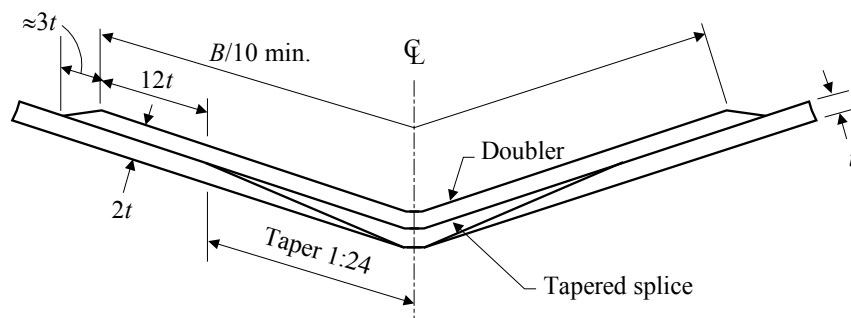
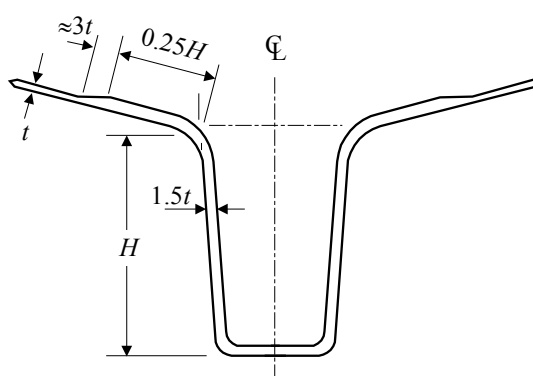


FIGURE 13
Vertical Keel or Skeg



7.3 Chines and Transoms

Chines and transoms are to be not less than shown in 3-2-6/Figures 14a through 14d.

FIGURE 14a
Chine or Transom – Single Skin Construction

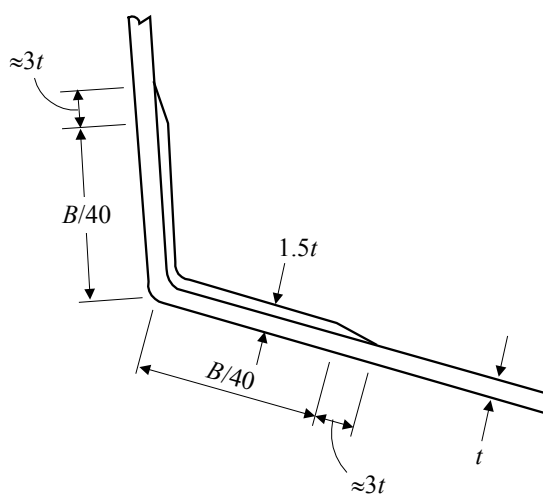


FIGURE 14b
Chine or Transom – Sandwich Construction

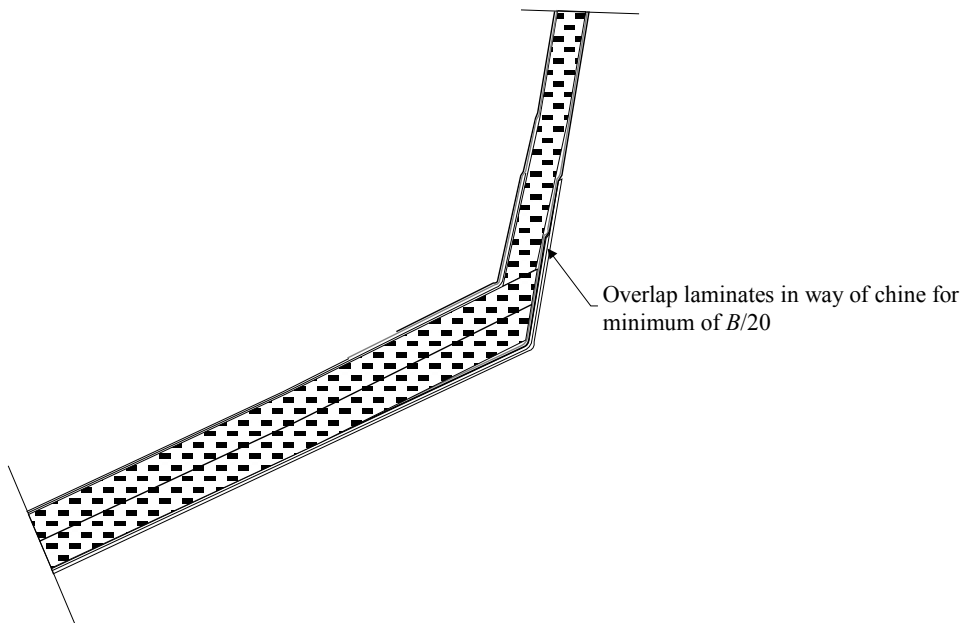


FIGURE 14c
Stepped Chine – Foam Wedge Option

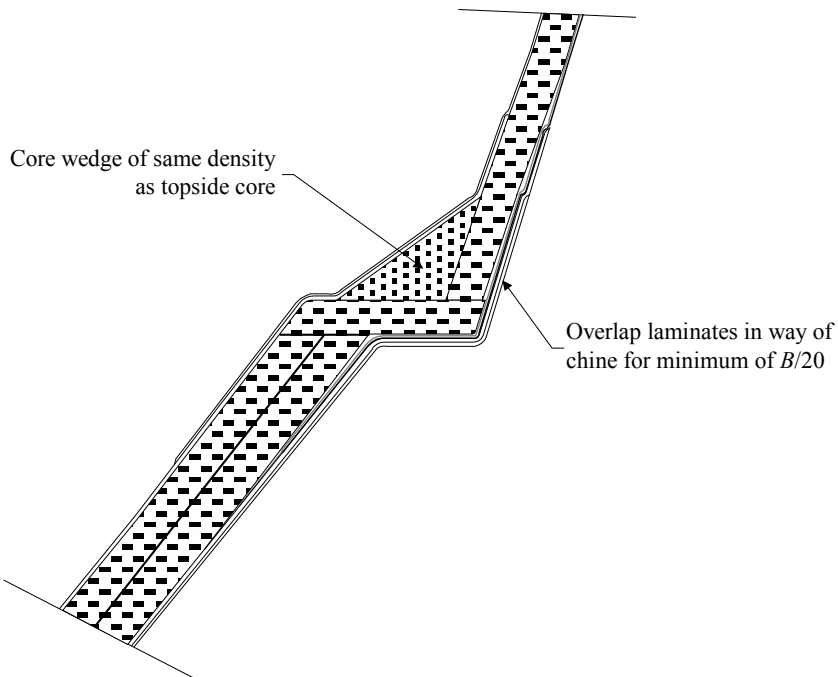
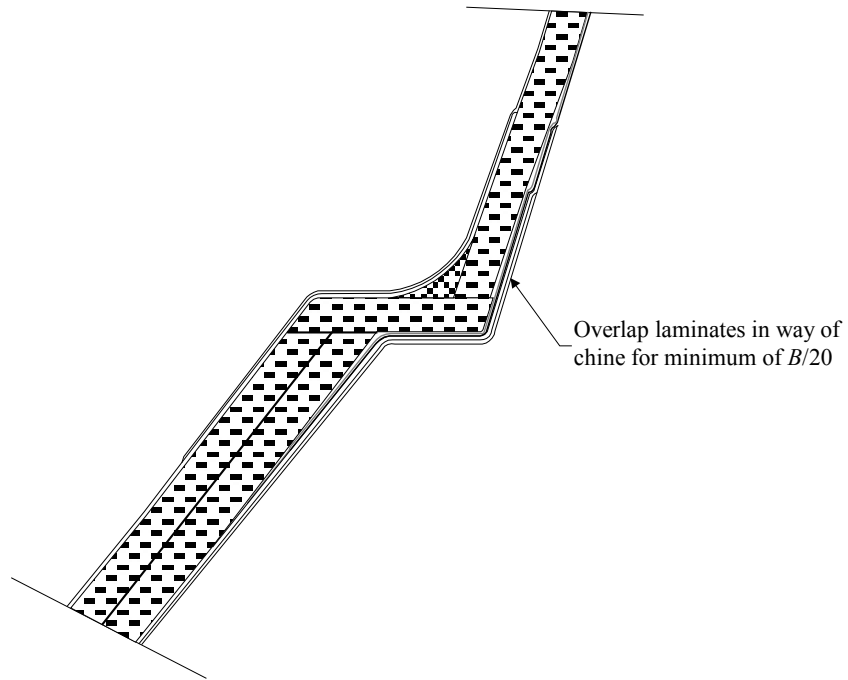


FIGURE 14d
Stepped Chine – Putty Radius



PART 3

CHAPTER 2 Hull Structures and Arrangements

SECTION 7 Keels, Stems, Shaft Struts, and Propeller Nozzles

1 Materials

1.1 Ordinary Strength Steels

The requirements in the following subsections are based upon ordinary strength steel. For higher strength steels and aluminum alloys see 3-2-7/1.3.

1.3 High Strength Steels and Aluminum Alloys

Unless otherwise specified, the required section modulus and inertia for high strength steels and aluminum alloys are as follows:

$$SM = SM_s Q$$

$$I = I_s E_s / E_o$$

where

SM, I = required section modulus and inertia. Unless specifically stated otherwise, the properties about the minor axis (axis perpendicular to h or w) are to be used.

SM_s, I_s = section modulus and inertia obtained from the dimensions given for ordinary strength steel.

Q = as defined in 3-2-1/1.1.1

E_s = 2.06×10^5 N/mm² (21×10^3 kgf/mm², 30×10^6 psi)

E_o = modulus of the material being considered in N/mm² (kgf/mm², psi)

Use of materials other than steel or aluminum will be specially considered.

1.5 Fiber Reinforced Plastic

For fiber reinforced plastic hulls, keels and skegs are to have proportions as indicated in 3-2-6/Figure 11 and 3-2-6/Figure 12.

3 Keels

3.1 Bar Keels

Where bar keels are fitted the thickness and depth is not to be less than obtained from the following equations:

$$t = 0.625L + 12.5 \text{ mm}$$

$$t = 0.0075L + 0.50 \text{ in.}$$

$$h = 1.46L + 100 \text{ mm}$$

$$h = 0.0175L + 4 \text{ in.}$$

where

t = thickness, in mm (in.)

h = depth, in mm (in.)

L = length of craft, in m (ft), as defined in Section 3-1-1

Thicknesses and depths other than given above are acceptable provided the section moduli and moments of inertia about the transverse horizontal axis are not less than given above.

3.3 Plate Keels

The thickness of the steel plate keel throughout the length of the craft is to be not less than the bottom shell required in Section 3-2-3.

5 Stems

5.1 Bar Stems

Where bar stems are fitted the thickness and depth is not to be less than obtained from the following equations:

$$\begin{aligned}t &= 0.625L + 6.35 \text{ mm} & t &= 0.0075L + 0.25 \text{ in.} \\w &= 1.25L + 90 \text{ mm} & w &= 0.015L + 3.5 \text{ in.}\end{aligned}$$

where

$$\begin{aligned}t &= \text{thickness, in mm (in.)} \\w &= \text{width, in mm (in.)} \\L &= \text{length of craft, in m (ft), as defined in Section 3-1-1/3}\end{aligned}$$

This thickness and width is to be maintained between the keel and design load waterline. Above the designed load waterline they may be gradually reduced until the area at the head is 70% of that obtained from the equations.

Thicknesses and widths other than given above are acceptable provided the section moduli and moments of inertia about the longitudinal axis are not less than above. The thickness of the bar stem in general should also not be less than twice the shell thickness.

5.3 Plate Stems

Where plate stems are used, they are not to be less in thickness than the bottom shell plating required in 3-2-3/1 and 3-2-3/3, where s is the frame spacing, or 610 mm (24 in.) if greater. Plate stems are to be suitably stiffened.

7 Stern Frames

Craft that are fitted with stern frames, shoe pieces, rudder horns, and rudder gudgeons are to meet the applicable requirements in Section 3-2-13 of the *Rules for Building and Classing Steel Vessels*.

9 Shaft Struts

9.1 General

Tail-shaft (propeller-shaft) struts where provided may be of the V or I type. The following equations are for solid struts having streamline cross-sectional shapes. For struts other than ordinary strength steel see 3-2-7/1.3. For hollow section and non-streamlined struts, the equivalent cross sectional area, inertia, and section modulus (major axis) are to be maintained. For a streamlined cross-section strut, the inertia about the longitudinal axis is $wt^3/25$ and the section modulus about the same axis is $wt^2/12.5$. Generally each leg of a "V" strut are to have similar cross section. Alternative methods for the determination of "V" strut requirements can be found in Appendix 3-2-A3.

9.3 V Strut

9.3.1 Width

The width of each strut arm is not to be less than obtained from the following equation:

$$w = 2.27D$$

where

w = width of strut (major axis), in mm (in.)

D = required diameter of ABS Grade 2 tail shaft, in mm (in.). (see Section 4-3-1)

9.3.2 Thickness

The thickness of the strut is not to be less than obtained from the following equation:

$$t = 0.365D$$

where

t = thickness of strut (minor axis), in mm (in.)

D = required diameter of ABS Grade 2 tail shaft, in mm (in.)

Where the included angle is less than 45 degrees, the foregoing scantlings are to be specially considered.

9.5 I Strut

9.5.1 Width

The width of the strut arm is not to be less than obtained from the following equation:

$$w_1 = 3.22D$$

where

w_1 = width of strut (major axis) in mm (in.)

D = diameter of tail shaft in mm (in.)

9.5.2 Thickness

The thickness of the strut is not to be less than obtained from the following equation:

$$t_1 = 0.515D$$

where

t_1 = thickness of strut (minor axis), in mm (in.)

D = diameter of tail shaft, in mm (in.)

9.7 Strut Length

The length of the longer leg of a V strut or the leg of an I strut, measured from the outside perimeter of the strut barrel or boss to the outside of the shell plating, is not to exceed 10.6 times the diameter of the tail shaft. Where this length is exceeded, the width and thickness of the strut are to be increased, and the strut design will be given special consideration. Where strut length is less than 10.6 times required tailshaft diameter, the section modulus of the strut may be reduced in proportion to the reduced length, provided the section modulus is not less than 0.85 times Guide required section modulus.

9.9 Strut Barrel

The thickness of the strut barrel or boss is to be at least one-fifth the diameter of the tail shaft. The length of the strut barrel or boss is to be adequate to accommodate the required length of propeller-end bearings. Strut barrels constructed of aluminum are not subject to the corrections required by 3-2-7/1.3.

11 Propeller Nozzles

11.1 Application

The requirements in this section are applicable for propeller nozzles with inner diameter d of 5 meters (16.4 feet) or less. Nozzles of larger inner diameter are subject to special consideration with all supporting documents and calculations submitted for review.

11.3 Design Pressure

The design pressure of the nozzle is to be obtained from the following:

$$p_d = 10^{-6} \cdot c \cdot \varepsilon \cdot \left(\frac{N}{A_p} \right) \text{ N/mm}^2 \text{ (kgf/mm}^2, \text{ psi)}$$

where

- c = coefficient as indicated in 3-2-7/Table 1
- ε = coefficient as indicated in 3-2-7/Table 2, but not to be taken less than 10
- N = maximum shaft power, in kW (hp)
- A_p = propeller disc area
 $= D^2 \frac{\pi}{4}$, in m² (ft²)
- D = propeller diameter, in m (ft)

TABLE 1
Coefficient c

Propeller Zone (see 3-2-7/Figure 1)	c		
	p_d in N/mm ²	p_d in kgf/mm ²	p_d in psi
2	10.0	1.02	11.62×10^3
1 & 3	5.0	0.51	5.81×10^3
4	3.5	0.36	4.067×10^3

TABLE 2
Coefficient ε

	p_d in N/mm ²	p_d in kgf/mm ²	p_d in psi
ε	$21 - 2 \times 10^{-2} \left(\frac{N}{A_p} \right)$	$21 - 2 \times 10^{-2} \left(\frac{N}{A_p} \right)$	$21 - 16 \times 10^{-2} \left(\frac{N}{A_p} \right)$

11.5 Nozzle Cylinder

11.5.1 Shell Plate Thickness

The thickness of the nozzle shell plating, in mm (in.), is not to be less than:

$$t = t_o + t_c, \text{ but not to be taken less than } 7.5 \text{ (0.3) mm (in.)}$$

where

- t_o = thickness obtained from the following formula:

$$= c_n \cdot S_p \cdot \sqrt{p_d} \text{ mm (in.)}$$

 c_n = coefficient as indicated in 3-2-7/Table 3
 S_p = spacing of ring webs, in mm (in.)
 p_d = nozzle design pressure, in N/mm² (kgf/mm², psi), as defined in 3-2-7/11.3
 t_c = corrosion allowance determined by 3-2-7/Table 4
 K_n = nozzle material factor as defined in 3-2-8/1.3

TABLE 3
Coefficient c_n

	p_d in N/mm ²	p_d in kgf/mm ²	p_d in psi
c_n	1.58×10^{-1}	4.95×10^{-1}	1.32×10^{-2}

TABLE 4
Corrosion Allowance t_c

Value of t_o	t_c mm (in.)
If $t_o \leq 10.0$ (0.4)	1.5 (0.06)
If $t_o > 10.0$ (0.4)	the lesser of b_1, b_2
where $b_1 = 3.0$ (0.12) mm (in.) $b_2 = \left(\frac{t_o}{\sqrt{K_n}} + 5 \right) \times 10^{-1}$ mm or $b_2 = \left(\frac{t_o}{\sqrt{K_n}} + 0.2 \right) \times 10^{-1}$ in.	

11.5.2 Internal Diaphragm Thickness

Thickness of nozzle internal ring web is not to be less than the required nozzle shell plating for Zone 3.

11.7 Nozzle Section Modulus

The minimum requirement for nozzle section modulus is obtained from the following formula:

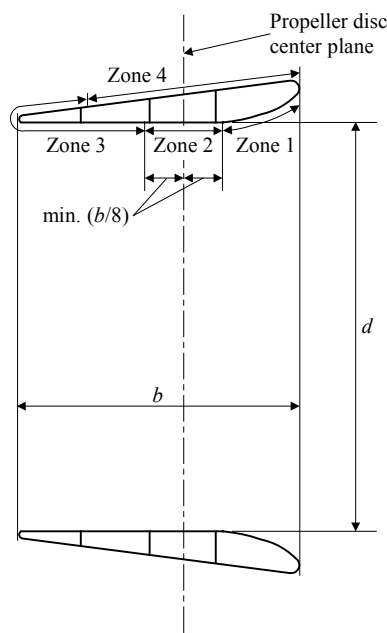
$$SM = d^2 b V_d^2 Q n \text{ cm}^3 (\text{in}^3)$$

where

- d = nozzle inner diameter, in m (ft)
 b = nozzle length, in m (ft)
 V_d = design speed in ahead condition, in knots, as defined in 3-2-8/3.1

- Q = reduction factor conditional on material type
- = 1.0 for ordinary strength steel
 - = 0.78 for H32 strength steel
 - = 0.72 for H36 strength steel
 - = 0.68 for H40 strength steel
- Q factor for steel having yield strength other than above is to be specially considered
- n = nozzle type coefficient taken equal to 0.7 (0.0012) for fixed nozzles

FIGURE 1
Propeller Nozzle Section View



- b = nozzle length
- d = nozzle inner diameter
- Zone 1 zone of nozzle inner skin from nozzle leading edge to the fore end of Zone 2
- Zone 2 zone of nozzle inner skin in way of propeller tips with two ring webs within the zone; the length on each side of the propeller center plane is not to be less than $1/8$ of the nozzle length b
- Zone 3 zone of nozzle inner and outer skin covering the tail vicinity, from aft end of Zones 2 to the aft end of Zone 4
- Zone 4 zone of nozzle outer skin from the leading edge to the fore end of Zone 3

11.9 Welding Requirement

The inner and outer nozzle shell plating is to be welded to the internal stiffening ring webs with double continuous welds as far as practicable. Plug/slot welding is prohibited for the inner shell, but may be accepted for the outer shell plating, provided that the nozzle ring web spacing is not greater than 350 mm (13.8 in.)

PART

3

CHAPTER 2 Hull Structures and Arrangements

SECTION 8 Rudders

1 General

1.1 Application

Requirements specified in this Section are applicable to:

- i) Ordinary profile rudders described in 3-2-8/Table 1A with rudder operating angle range from -35° to $+35^\circ$.
- ii) High-lift rudders described in 3-2-8/Table 1B, the rudder operating angle of which might be exceeding 35° on each side at maximum design speed.

Rudders not covered in 3-2-8/Table 1A nor in 3-2-8/Table 1B are subject to special consideration, provided that all the required calculations are prepared and submitted for review in full compliance with the requirements in this section.

Special consideration will be given to aluminum rudder stocks and fiber reinforced plastic rudders and rudder stocks. Material specifications are to be listed on the plans.

1.3 Rudder and Rudder Stock Materials

Rudder stocks, pintles, coupling bolts, and keys are to be of material in accordance with the requirements of Chapter 1 of the *ABS Rules for Materials and Welding (Part 2)*. The Surveyor needs not witness material tests for coupling bolts and keys. The surfaces of rudder stocks in way of exposed bearings are to be of non-corrosive material.

Material factors of castings and forgings used for the shoe piece (K_g), horn (K_h), stock (K_s), bolts (K_b), coupling flange (K_f), pintles (K_p), and nozzles (K_n) are to be obtained for their respective material from the following equation:

$$K = (n_y/Y)^e$$

where

- | | | |
|-------|---|---|
| n_y | = | 235 N/mm ² (24 kgf/mm ² , 34000 psi) |
| Y | = | specified minimum yield strength of the material, in N/mm ² (kgf/mm ² , psi), but is not to be taken as greater than $0.7U$ or 450 N/mm ² (46 kgf/mm ² , 65000 psi) whichever is lesser |
| U | = | minimum tensile strength of material used, in N/mm ² (kgf/mm ² , psi) |
| e | = | 1.0 for $Y \leq 235$ N/mm ² (24 kgf/mm ² , 34000 psi) |
| | = | 0.75 for $Y > 235$ N/mm ² (24 kgf/mm ² , 34000 psi) |

For craft receiving the **OE** notation as defined in 1-1-3/Table B, Y may be specially considered.

1.5 Expected Torque

The torque considered necessary to operate the rudder in accordance with 4-3-3/5.4) is to be indicated on the submitted rudder or steering gear plan. See 4-3-3/1.5 and 3-2-8/5.7.

Note that this expected torque is not the design torque for rudder scantlings.

1.7 Rudder Stops

Strong and effective structural rudder stops are to be fitted. Where adequate positive mechanical stops are provided within the steering gear in accordance with 4-3-3/5.1, structural stops will not be required.

3 Rudder Design Force

Rudder force, C_R , upon which rudder scantlings are to be based, is to be obtained from equation described either in Section 3-2-8/3.1 or Section 3-2-8/3.3 as applicable. Where for the ordinary rudders the rudder angle, ϕ , exceeds 35° , the rudder force, C_R , is to be increased by a factor of $1.74 \sin(\phi)$.

3.1 Rudder Blades without Cutouts

Where the rudder profile can be defined by a single quadrilateral, the rudder force is to be obtained from the following equation.

$$C_R = n k_R k_c k_\ell A V_R^2 \quad \text{kN (tf, Ltf)}$$

where

$$n = 0.132 \text{ (0.0135, 0.00123)}$$

$$k_R = (b^2/A_t + 2)/3 \text{ but not taken more than 1.33}$$

$$b = \text{mean height of rudder area, in m (ft), as determined from 3-2-8/Figure 1}$$

$$A_t = \text{sum of rudder blade area, } A, \text{ and the area of rudder post or rudder horn within the extension of rudder profile, in m}^2 \text{ (ft}^2\text{)}$$

$$A = \text{total projected area of rudder as illustrated in 3-2-8/Figure 1, in m}^2 \text{ (ft}^2\text{)}$$

For steering nozzles, A is not to be taken less than 1.35 times the projected area of the nozzle.

$$k_c = \text{coefficient depending on rudder cross section as indicated in 3-2-8/Table 1A and 1B. For cross section differing from those in 3-2-8/Table 1A and 1B, } k_c \text{ is subject to special consideration.}$$

$$k_\ell = \text{coefficient as specified in 3-2-8/Table 2}$$

$$V_R = \text{craft speed, in knots}$$

$$= \text{for ahead condition } V_R \text{ equals } V_d \text{ or } V_{\min}, \text{ whichever is greater}$$

$$= \text{for astern condition } V_R \text{ equals } V_a \text{ or } 0.5V_d, \text{ or } 0.5V_{\min}, \text{ whichever is greater}$$

$$V_d = \text{design speed in knots with the craft running ahead at the maximum continuous rated shaft rpm and at the summer load waterline}$$

$$V_a = \text{maximum astern speed in knots}$$

$$V_{\min} = (V_d + 20)/3$$

3.3 Rudder Blades with Cutouts

This paragraph applies to rudders with cutouts (semi-spade rudders), such that the whole blade area cannot be adequately defined by a single quadrilateral. See 3-2-8/Figure 2. Equations derived in this paragraph are based on a cutout blade with two quadrilaterals. Where more quadrilaterals are needed to define the rudder shape, similar rules apply.

The total rudder force described in 3-2-8/3.1 is applicable for rudders with cutout(s), with A being the summation of sub-quadrilaterals that make up the whole area of the rudder blade. Rudder force distribution over each quadrilateral is to be obtained from the following equations:

$$C_{R1} = C_R A_1/A \quad \text{kN (tf, Ltf)}$$

$$C_{R2} = C_R A_2/A \quad \text{kN (tf, Ltf)}$$

where

C_R and A are as defined in 3-2-8/3.1

A_1 and A_2 are as described in 3-2-8/Figure 2.

TABLE 1A
Coefficient k_c for Ordinary Rudders

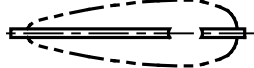
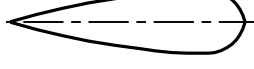

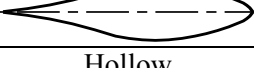
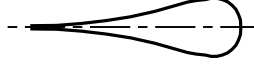
	Profile Type	k_c	
		Ahead Condition	Astern Condition
1	Single plate 	1.0	1.0
2	NACA-OO Göttingen 	1.1	0.80
3	Flat side 	1.1	0.90
4	Mixed (e.g., HSVA) 	1.21	0.90
5	Hollow 	1.35	0.90

TABLE 1B
Coefficient k_c for High-Lift/Performance Rudders

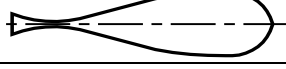
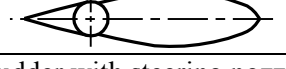

	Profile Type	k_c	
		Ahead Condition	Astern Condition
1	Fish tail (e.g., Schilling high-lift rudder) 	1.4	0.8
2	Flap rudder 	1.7	1.3
3	Rudder with steering nozzle 	1.9	1.5

FIGURE 1
Rudder Blade without Cutouts

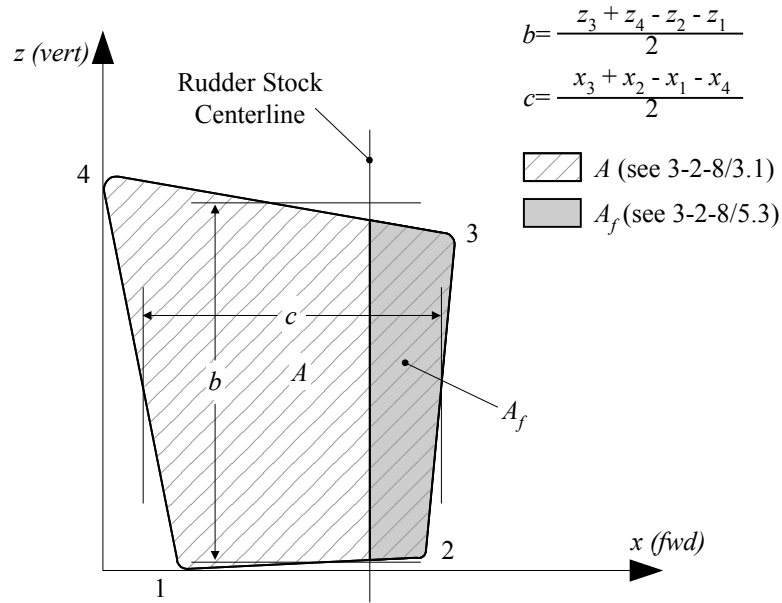
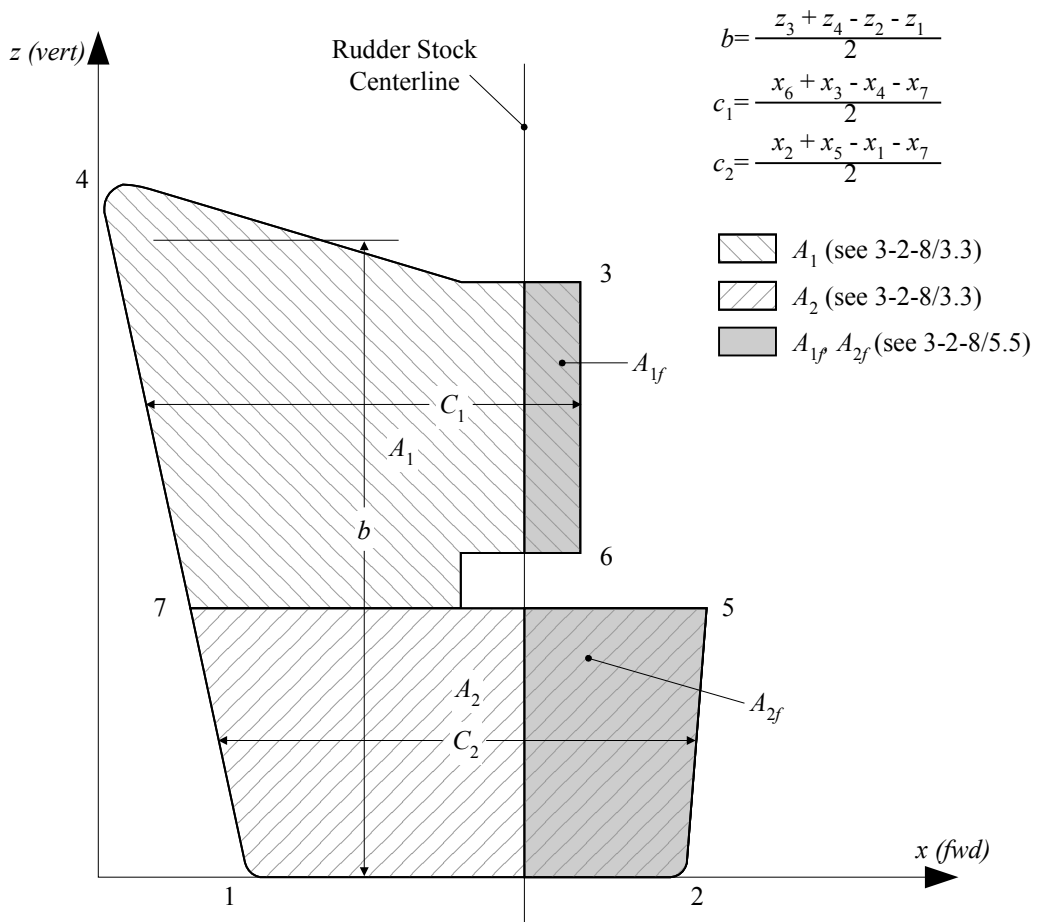


FIGURE 2
Rudder Blade with Cutouts



5 Rudder Design Torque

5.1 General

The rudder design torque, Q_R , for rudder scantling calculations is to be in accordance with 3-2-8/5.3 or 3-2-8/5.5 as applicable.

5.3 Rudder Blades without Cutouts

Rudder torque, Q_R , is to be determined from the following equation for both ahead and astern conditions.

$$Q_R = C_{R'} r \text{ kN-m (tf-m, Ltf-ft)}$$

where

- $C_{R'}$ = rudder force as calculated in 3-2-8/3.1
- r = $c(\alpha - k)$ (but not less than $0.1c$ for ahead condition)
- c = mean breadth of rudder area, as shown in 3-2-8/Figure 1, in m (ft)
- α = coefficient as indicated in 3-2-8/Table 3
- k = A_f/A
- A_f = area of rudder blade situated forward of the centerline of the rudder stock, in m^2 (ft^2), as shown in 3-2-8/Figure 1
- A = whole rudder area as described in 3-2-8/3.1

TABLE 2
Coefficient k_ℓ

<i>Rudder/Propeller Layout</i>	k_ℓ
Rudders outside propeller jet	0.8
Rudders behind a fixed propeller nozzle	1.15
All others	1.0

TABLE 3
Coefficient α

<i>Rudder Position or High-lift</i>	α	
	<i>Ahead Condition</i>	<i>Astern Condition</i>
Located behind a fixed structure, such as a rudder horn	0.25	0.55
Located where no fixed structure forward of it	0.33	0.66
High-Lift Rudders (see 3-2-8/Table 1B)	Special consideration (0.40 if unknown)	Special consideration

5.5 Rudders Blades with Cutouts

This paragraph refers to rudder blades with cutouts (semi-spade rudders) as defined in 3-2-8/3.3. Equations derived in this paragraph are based on a cutout blade with two quadrilaterals. Where more quadrilaterals are needed to define the rudder shape, similar rules apply.

Total rudder torque, Q_R , in ahead and astern conditions is to be obtained from the following equation:

$$Q_R = C_{R1} r_1 + C_{R2} r_2 \quad \text{kN-m (tf-m, Ltf-ft)}$$

but not to be taken less than Q_{Rmin} in the ahead condition

where

$$Q_{Rmin} = 0.1 C_R (A_1 c_1 + A_2 c_2) / A$$

$$r_1 = c_1 (\alpha - k_1) \quad \text{m (ft)}$$

$$r_2 = c_2 (\alpha - k_2) \quad \text{m (ft)}$$

$$c_1, c_2 = \text{mean breadth of partial area } A_1, A_2, \text{ from 3-2-8/Figure 2}$$

$$\alpha = \text{coefficient as indicated in 3-2-8/Table 3}$$

$$k_1, k_2 = A_{1f}/A_1, A_{2f}/A_2 \text{ where } A_{1f}, A_{2f} = \text{area of rudder blade situated forward of the centerline of the rudder stock for each part of the rudder, as shown in 3-2-8/Figure 2}$$

$C_R, C_{R1}, C_{R2}, A_1, A_2$ are as defined in 3-2-8/3.3.

5.7 Trial Conditions

The above equations for Q_R are intended for the design of rudders and should not be directly compared with the torques expected during the trial (see 3-2-8/1.5) or the rated torque of steering gear (see 4-3-3/5.4).

7 Rudder Stocks

7.1 Upper Rudder Stocks

The upper rudder stock is that part of the rudder stock above the neck bearing or above the top pintle, as applicable.

$$S = N_u \sqrt[3]{Q_R K_S} \quad \text{mm (in.)}$$

where

$$N_u = 42.0 (89.9, 2.39)$$

$$Q_R = \text{rudder torque, as defined in 3-2-8/5, in kN-m (tf-m, Ltf-m)}$$

$$K_S = \text{material factor for upper rudder stock, as defined in 3-2-8/1.3}$$

7.3 Lower Rudder Stocks

In determining lower rudder stock scantlings, values of rudder design force and torque calculated in 3-2-8/3 and 3-2-8/5 are to be used. Bending moments, shear forces, as well as the reaction forces are to be determined from 3-2-8/7.7 and 3-2-8/13.5, and are to be submitted for review. For rudders supported by shoe pieces or rudder horns, these structures are to be included in the calculation model to account for support of the rudder body. Guidance for calculation of these values is given in Appendix 3-2-A1.

The lower rudder stock diameter is not to be less than obtained from the following equation:

$$S_\ell = S \sqrt[6]{1 + (4/3)(M/Q_R)^2} \quad \text{mm (in.)}$$

where

- S = upper stock required diameter from 3-2-8/7.1, in mm (in.)
- S_ℓ = lower stock required diameter.
- M = bending moment at the section of the rudder stock considered, in kN-m (tf-m, Ltf-ft)
- Q_R = rudder torque from 3-2-8/5, in kN-m (tf-m, Ltf-ft)

Above the neck bearing a gradual transition is to be provided where there is a change in the diameter of the rudder stock.

The equivalent stress of bending and torsion, σ_c to be assessed from the aforementioned direct calculation in the transition is not to exceed $118 / K \text{ N/mm}^2$ ($12.0 / K \text{ kgf/mm}^2$, $17100 / K \text{ lbs/in}^2$).

$$\sigma_c = K \sqrt{\sigma_b^2 + 3\tau^2}$$

where

- K = material factor as defined in 3-2-8/1.3.
- σ_b = $10.2M / S_\ell^3$
- τ = $5.1Q_R / S_\ell^3$

7.5 Rudder Stock Sealing

- i) In rudder trunks which are open to the sea, a seal or stuffing box is to be fitted above the deepest load waterline, to prevent water from entering the steering gear compartment and the lubricant from being washed away from the rudder carrier.
- ii) Where the top of the rudder trunk is below the deepest waterline two separate stuffing boxes are to be provided.

7.7 Bending Moments

The bending moment on the rudder and rudder stock may be determined in accordance with Appendix 3-2-A1 or in accordance with the following equations:

7.7.1 Spade Rudders

$$M_n = C_R \ell_n \quad \text{kN-m (Ltf-ft)}$$

$$M_s = C_R \frac{A_1}{A} \ell_c \quad \text{kN-m (Ltf-ft)}$$

where

- M_n = bending moment at neck bearing.
- M_s = bending moment at section under consideration.
- ℓ_n = distance from center of neck bearing to the centroid of rudder area, m (ft)
- ℓ_c = distance from section under consideration to the centroid of rudder area, A_1 , m (ft)
- A_1 = area below section under consideration, m^2 (ft^2)

C_R and A are defined in 3-2-8/3.

7.7.2 Balanced Rudders with Shoepiece Support

The bending moment at the neck bearing may be taken as indicated below. Bending moments at other locations are to be determined by direct calculation and are to be submitted. See Appendix 3-2-A1 for guidance in calculating bending moments.

$$M_n = NC_R \ell_b \text{ kN-m (Ltf-ft)}$$

where

M_n = bending moment at neck bearing

ℓ_b = distance between center of neck bearing and center of shoepiece pintle bearing, m (ft)

$$N = \left[\frac{0.5 + \frac{\alpha_1}{8}}{1 + \alpha_1 \left(1 + \frac{\ell_u}{\ell_b} \frac{I_b}{I_u} \right)} \right]$$

$$\alpha_1 = \frac{\ell_b^3 I_d}{\ell_s^3 I_b}$$

I_d = mean moment of inertia of shoepiece about the vertical axis, cm⁴ (in⁴)

ℓ_s = distance between center of shoepiece pintle bearing and the effective support point of the shoepiece in the hull, m (ft)

I_b = mean moment of inertia of the rudder, cm⁴ (in⁴), considering a width of rudder plating twice the athwartship dimension of the rudder and excluding welded or bolted cover plates for access to pintles, inc.

ℓ_u = distance between center of the neck bearing and the center of the rudder carrier bearing, m (ft)

I_u = mean moment of inertia of rudder stock, between neck bearing and rudder carrier bearing, cm⁴, (in⁴)

C_R is as defined in 3-2-8/3.

9 Flange Couplings

9.1 General

Rudder flange couplings are to comply with the following requirements:

- i) Couplings are to be supported by an ample body of metal worked out from the rudder stock.
- ii) The smallest distance from the edge of the bolt holes to the edge of the flange is not to be less than two-thirds of the bolt diameter.
- iii) Coupling bolts are to be fitted bolts.
- iv) Suitable means are to be provided for locking the nuts in place.

In addition to the above, rudder flange couplings are to meet the type-specific requirements in 3-2-8/9.3 (horizontal couplings) or 3-2-8/9.5 (vertical couplings) as applicable.

9.3 Horizontal Couplings

9.3.1 Coupling Bolts

There are to be at least six coupling bolts in horizontal couplings, and the diameter, d_b , of each bolt is not to be less than obtained by the following equation:

$$d_b = 0.62 \sqrt{d_s^3 K_b / (nrK_s)} \quad \text{mm (in.)}$$

where

- d_s = required rudder stock diameter, S (3-2-8/7.1) or S_ℓ (3-2-8/7.3) as applicable, in way of the coupling
- n = total number of bolts in the horizontal coupling
- r = mean distance, in mm (in.), of the bolt axes from the center of the bolt system
- K_b = material factor for bolts, as defined in 3-2-8/1.3
- K_s = material factor for stock, as defined in 3-2-8/1.3

9.3.2 Coupling Flange

Coupling flange thickness is not to be less than the greater of the following equations:

$$t_f = d_{bt} \sqrt{K_f / (K_b)} \quad \text{mm (in.)}$$

$$t_f = 0.9d_{bt} \quad \text{mm (in.)}$$

where

- d_{bt} = calculated bolt diameter as per 3-2-8/9.3.1 based on a number of bolts not exceeding 8
- K_f = material factor for flange, as defined in 3-2-8/1.3
- K_b = material factor of bolts, as defined in 3-2-8/1.3

9.5 Vertical Couplings

9.5.1 Coupling Bolts

There are to be at least eight coupling bolts in vertical couplings and the diameter, d_b , of each bolt is not to be less than obtained from the following equation:

$$d_b = 0.81d_s \sqrt{K_b / (nK_s)} \quad \text{mm (in.)}$$

where

- n = total number of bolts

d_s, K_b, K_s are as defined in 3-2-8/9.3.

In addition, the first moment of area, m , of the bolts about the center of the coupling is not to be less than given by the following equation:

$$m = 0.00043d_s^3 \quad \text{mm}^3 \text{ (in}^3\text{)}$$

where

- d_s = diameter as defined in 3-2-8/9.3

9.5.2 Coupling Flange

Coupling flange thickness, t_f , is not to be less than d_b , as defined in 3-2-8/9.5.1.

11 Tapered Stock Couplings

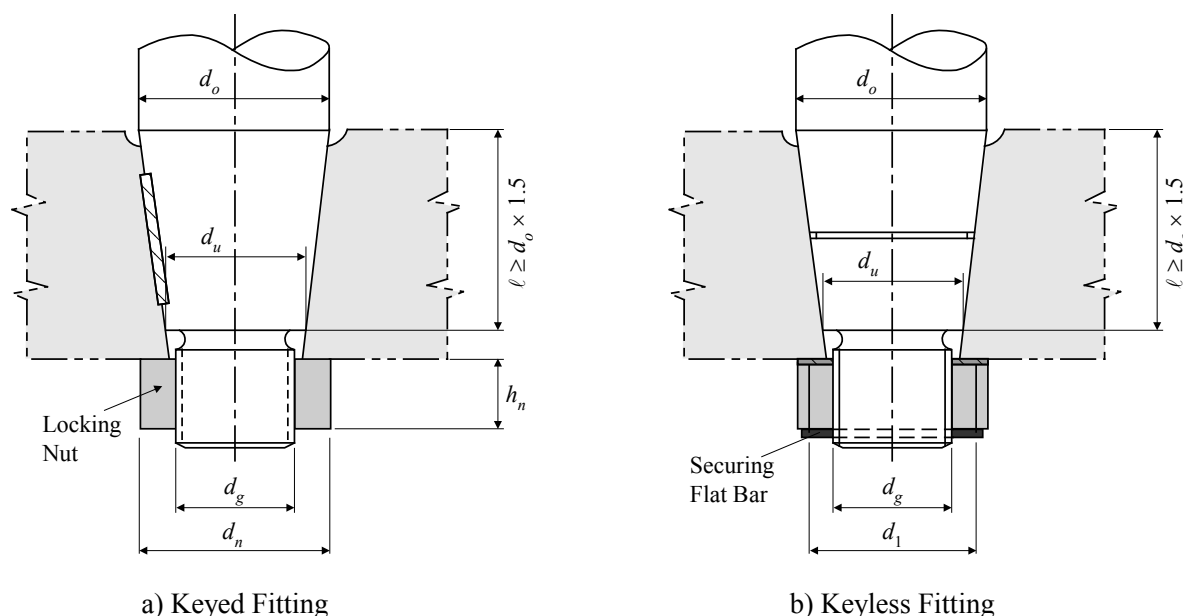
11.1 Coupling Taper

Tapered stock couplings are to comply with the following general requirements in addition to type-specific requirements given in 3-2-8/11.3 or 3-2-8/11.5 as applicable:

- i) Tapered stocks, as shown in 3-2-8/Figure 3, are to be effectively secured to the rudder casting by a nut on the end.
- ii) Taper length (ℓ) in the casting is generally not to be less than 1.5 times the stock diameter (d_o) at the top of the rudder.
- iii) The taper on diameter (c) is to be 1/12 to 1/8 for keyed taper couplings and 1/20 to 1/12 for couplings with hydraulic mounting/dismounting arrangements, as shown in the following table.
- iv) Where mounting with an oil injection and hydraulic nut, the push-up oil pressure and the push-up length are to be specially considered upon submission of calculations.

Type of Coupling Assembly	$c = \frac{d_o - d_u}{\ell}$
Without hydraulic mounting/dismounting	$1/12 \leq c \leq 1/8$
With hydraulic mounting/dismounting	$1/20 \leq c \leq 1/12$

FIGURE 3
Tapered Couplings



11.3 Keyed Fitting

Where the stock, it is to be fitted in accordance with the following:

- i) The top of the keyway is to be located well below the top of the rudder.
- ii) Torsional strength of the key equivalent to that of the required upper stock is to be provided.
- iii) The effective shear area* of the key is not to be less than A_k , given below.

$$A_k = \frac{S^3}{5.1r_{md}} \cdot \frac{Y_S}{Y_K}$$

where

- A_k = shear area of key; mm² (in²)
- S = required upper stock diameter; mm (in.); as determined by 3-2-8/7.1
- r_{md} = offered radius of tapered stock at mid length of the bearing surface of the key; mm (in.)
- Y_S = specified minimum yield strength of keyway material; N/mm² (kgf/mm², psi)
- Y_K = specified minimum yield strength of key material; N/mm² (kgf/mm², psi)

- iv) In general, the key material is to be at least of equal strength to the keyway material. For keys of higher strength materials, shear and bearing areas of keys and keyways may be based on the respective material properties of the keys and the keyways, provided that compatibilities in mechanical properties of both components are fully considered. In no case, is the bearing stress of the key on the keyway to exceed 90% of the specified minimum yield strength of the keyway material.

* Note: The effective area is to be the gross area reduced by any area removed by saw cuts, set screw holes, chamfer, etc., and is to exclude the portion of the key in way of spooning of the key way.

11.5 Keyless Fitting

Hydraulic and shrink fit keyless couplings are to be fitted in accordance with the following:

- i) Hydraulic pressure is to be specially considered upon submittal of detailed preloading stress calculations and fitting instructions;
- ii) The calculated torsional holding capacity is to be at least 2.0 times the transmitted torque based on the steering gear relief valve setting;
- iii) Preload stress is not to exceed 70% of the minimum yield strength of either the stock or the bore;
- iv) Prior to applying hydraulic pressure, at least 75% of theoretical contact area of rudder stock and rudder bore is to be achieved in an evenly distributed manner;
- v) The upper edge of the upper main piece bore is to have a slight radius;
- vi) The locking nut is to be fitted in accordance with 3-2-8/11.7.

11.7 Locking Nut

Dimensions of the securing nut, as shown in 3-2-8/Figure 3, are to be proportioned in accordance with the following and the nut is to be fitted with an effective locking device.

- Height $h_n \geq 0.6 d_g$
- Outer diameter of nut $d_n \geq 1.2d_u$ or $1.5d_g$, whichever is greater
- External thread diameter $d_g \geq 0.65 d_o$

In the case of a hydraulic pressure secured nut, a securing device such as a securing flat bar is to be provided. Calculations proving the effectiveness of the securing device are to be submitted.

13 Pintles

13.1 General

- i) Pintles are to be fitted in the gudgeons by conical attachment to the full extent of the gudgeon depth
- ii) The depth of the pintle boss is not to be less than the required pintle diameter d_p , and bearing length is to be between 1.0 and 1.2 times d_p .
- iii) The taper on the diameter is to be:
 - 1/12 to 1/8 for keyed and other manually assembled pintles with locking nut.
 - 1/20 to 1/12 for pintle mounted with oil injection and hydraulic nut.
- iv) Threads and nuts are to be in accordance with 3-2-8/11.7.
- v) For rudders on horns with two pintles, as shown in 3-2-13/Figure 3b of the *Steel Vessel Rules*, calculations are to include pintle bearing forces with the craft running ahead at the maximum continuous rated shaft rpm and at the lightest operating draft.
- vi) The bearing allowable pressure is to be in accordance with 3-2-8/Table 6.

13.3 Diameter

The diameter of the pintles is not to be less than obtained from the following equation.

$$d_p = k_1 \sqrt{BK_p} \quad \text{mm (in.)}$$

where

- k_1 = 11.1 (34.7, 1.38)
- B = bearing force, in kN (tf, Ltf), from 3-2-8/13.5 but not to be taken less than B_{\min} as specified in 3-2-8/Table 4
- K_p = material factor for the pintle, as defined in 3-2-8/1.3

TABLE 4
Minimum Bearing Force B_{\min}

Pintle Type		B_{\min}
Conventional two pintle rudder		$0.5 C_R$
3-2-A1/Figure 2	lower pintle	$0.5 C_R$
3-2-A1/Figure 3	main pintle	$C_R \ell_a / \ell_p^*$
3-2-13/Figure 3 of the <i>Steel Vessel Rules</i>	main pintle	$C_R \ell_a / \ell_p^*$
	upper pintle	$0.25 C_R$

* $B_{\min} = C_R$ where $\ell_a / \ell_p \geq 1$

ℓ_a, ℓ_p as described in 3-2-13/Figure 3 of the *Steel Vessel Rules*

13.5 Shear and Bearing Forces

The shear and bearing forces may be determined in accordance with Appendix 3-2-A1, or by the equations given below.

13.5.1 Spade Rudder

$$\text{Bearing force at rudder carrier: } P_u = \frac{M_n}{\ell_u} \text{ kN (tf, Ltf)}$$

$$\text{Bearing force at neck bearing: } P_n = C_R + P_u \text{ kN (tf, Ltf)}$$

$$\text{Shear force at neck bearing: } F_n = C_R \text{ kN (tf, Ltf)}$$

where C_R is as defined in 3-2-8/3 and ℓ_u is as defined in 3-2-8/7.7.2.

13.5.2 Balanced Rudder with Shoepiece Support

$$\text{Bearing force at rudder carrier: } P_u = \frac{M_n}{\ell_u} \text{ kN (tf, Ltf)}$$

$$\text{Bearing force at neck bearing: } P_n = P_u \left(1 + \frac{\ell_u}{\ell_b} \right) + \frac{C_R}{\ell_b} \left(\frac{\ell_R}{2} + \ell_p \right) \text{ kN (tf Ltf)}$$

where

ℓ_b = distance between the center of neck bearing support and the center of shoepiece support, as shown in 3-2-A1/Figure 2

$$= \ell_p + \ell_r + \ell_\ell$$

ℓ_p = distance between bottom of rudder blade and center of support of neck bearing

ℓ_ℓ = distance between top of rudder blade and center of support of neck bearing

$$\text{Bearing force at shoepiece: } P_p = C_R + P_u - P_n \text{ kN (tf, Ltf) but not less than } 0.5C_R$$

$$\text{Shear force at neck bearing: } F_n = P_n - P_u \text{ kN (tf, Ltf)}$$

where C_R is as defined in 3-2-8/3.

15 Supporting and Anti-Lifting Arrangements

15.1 Bearings

15.1.1 Bearing Surfaces

Bearing surfaces for rudder stocks, shafts and pintles are to meet the following requirements:

- i) The length/diameter ratio (ℓ_b/d_ℓ) of the bearing surface is not to be greater than 1.2*
- ii) The projected area of the bearing surface ($A_b = d_\ell \ell_b$) is not to be less than A_{bmin} ,

where

d_ℓ = outer diameter of the liner, in mm (in.)

ℓ_b = bearing length, in mm (in.)

$$A_{bmin} = k_1 \frac{P}{p_a} \text{ mm}^2 \text{ (in}^2\text{)}$$

$$k_1 = 1000 \text{ (2240)}$$

- P = bearing reaction force, in kN (tf, Ltf), as specified in 3-2-8/Table 5
- p_a = allowable surface pressure, as indicated in 3-2-8/Table 6 depending on bearing material, in N/mm² (kgf/mm², lbs/in²)
- * Request for bearing arrangement of length/diameter ratio greater than 1.2 is subject to special consideration provided that calculations are submitted to show acceptable clearance at both ends of the bearing.

15.1.2 Bearing Clearance

- i) The clearance for metal bearings is not to be less than $d_i/1000 + 1.0$ mm ($d_i/1000 + 0.04$ in.) on the diameter, where d_i is the inner diameter of the bushing, in mm (in.).
- ii) The clearance for non-metallic bearings is to be specially determined considering the material's swelling and thermal expansion properties. This clearance in general is not to be taken less than 1.5 mm (0.06 in.) on diameter*.
- * Request of clearance less than 1.5 mm (0.06 in.) for non-metallic bearings is subject to special considerations provided that documented evidence, such as manufacturer's recommendation on acceptable clearance, expansion allowance and satisfactory service history with reduced clearances, are submitted for review.

For spade rudders with a rudder stock diameter of 400 mm (15.75 in.) or less, the clearances on the diameter are not to be less than given below:

Stock Diameter, mm (in.)	Metallic Bushing, mm (in.)	Synthetic Bushing ⁽¹⁾ , mm (in.)
400 (15.75)	1.15 (0.045)	1.15 (0.045) + E ⁽²⁾
300 (11.81)	0.85 (0.033)	0.85 (0.033) + E
200 (7.87)	0.78 (0.031)	0.78 (0.031) + E
100 (3.94)	0.75 (0.030)	0.75 (0.030) + E

Notes

- 1 The bushing manufacturer's recommended running clearance may be used as an alternative to these clearances.
- 2 E = expansion allowance provided by bushing manufacturer, mm (in.).

15.1.3 Bearing Pressure

Bearing pressure is to be accordance with 3-2-8/Table 6.

15.1.4 Bearing Material

Where stainless steel or wear-resistant steel is used for liners or bearings, the material properties including chemical composition of both components are to be submitted for review for an approved combination.

TABLE 5
Bearing Reaction Force

Bearing Type	P , Bearing Reaction Force kN (tf, Ltf)
Pintle bearings	$P = B$ as defined in 3-2-8/13
Other bearings	Calculation of P is to be submitted. Guidelines for calculation can be found in Appendix 3-2-A1

TABLE 6
Allowable Bearing Surface Pressure

Bearing Material	p_a †		
	N/mm ²	kgf/mm ²	psi
lignum vitae	2.5	0.25	360
white metal, oil lubricated	4.5	0.46	650
Synthetic material with hardness between 60 and 70 Shore D*	5.5	0.56	800
Steel [§] , bronze and hot-pressed bronze-graphite materials	7.0	0.71	1000

- † Higher values than given in the table may be taken if they are verified by tests.
 § Stainless and wear-resistant steel in an approved combination with stock liner.
 * Indentation hardness test at 23°C and with 50% moisture, according to a recognized standard. Synthetic bearing materials to be of approved type.

15.3 Rudder Carrier

- i) The weight of the rudder assembly is to be supported by a rudder carrier mounted on the hull structure designed for that purpose.
- ii) At least half of the rudder carrier's holding-down bolts are to be fitted bolts. Alternative means of preventing horizontal movement of the rudder carrier may be considered.
- iii) Rudder carrier bearings are to comply with the requirements in 3-2-8/15.1.
- iv) Hull structures in way of the rudder carrier are to be suitably strengthened.

15.5 Anti Lifting Devices

Means are to be provided to prevent accidental unshipping or undue movement of the rudder which may cause damage to the steering gear. There are to be at least two bolts in the joint of the anti-lifting ring.

17 Double Plate Rudder

17.1 Strength

The section modulus and web area of the rudder mainpiece are to be such that the stresses indicated in the following Subparagraphs are not exceeded.

In calculating the section modulus of the rudder, the effective width of side plating is to be taken as not greater than twice the athwartship dimension of the rudder. Welded or bolted cover plates on access openings to pintles are not to be considered effective in determining the section modulus of the rudder. Generous radii are to be provided at abrupt changes in section where there are stress concentrations, including in way of openings and cover plates.

Moments, shear forces and reaction forces are to be as given in 3-2-8/7.7 and 3-2-8/13.5.

17.1.1 Clear of Cut-outs

Bending stress	$\sigma_b = K_b/Q$	N/mm ² (kgf/mm ² , psi)
Shear stress	$\tau = K_s/Q$	N/mm ² (kgf/mm ² , psi)
Equivalent stress	$\sigma_e = \sqrt{\sigma_b^2 + 3\tau^2} = K_e/Q$	N/mm ² (kgf/mm ² , psi)

where

	<i>SI units</i>	<i>MKS units</i>	<i>US units</i>
K_σ	110	11.2	15,900
K_τ	50	5.1	7,300
K_e	120	12.2	17,400

Q = as defined in 3-2-1/1.1.1

17.1.2 In way of Cut-outs

Allowable stresses for determining the rudder strength in way of cutouts (see 3-2-8/Figure 4) are as follows:

Bending stress $\sigma_b = K_\sigma/Q$ N/mm² (kgf/mm², psi)

Shear stress $\tau = K_\tau/Q$ N/mm² (kgf/mm², psi)

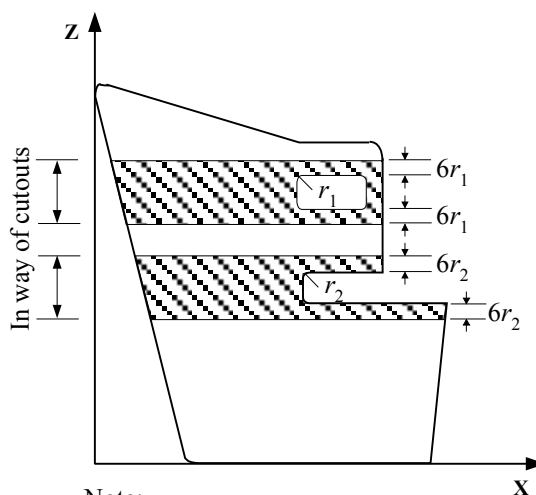
Equivalent stress $\sigma_e = \sqrt{\sigma_b^2 + 3\tau^2} = K_e/Q$ N/mm² (kgf/mm², psi)

where

	<i>SI units</i>	<i>MKS units</i>	<i>US units</i>
K_σ	75	7.65	10,900
K_τ	50	5.1	7,300
K_e	100	10.2	14,500

Q = as defined in 3-2-1/1.1.1

FIGURE 4



Note:

r_1 = corner radius of rudder plate in way of portable bolted inspection hole

r_2 = corner radius of rudder plate

The mainpiece of the rudder is to be formed by the rudder side plating (but not more than the effective width indicated above) and vertical diaphragms extending the length of the rudder or the extension of the rudder stock or a combination of both.

For spade rudders, the section modulus at the bottom of the rudder is not to be less than one-third the required section modulus of the rudder at the top of the rudder or at the center of the lowest pintle.

Where rudders have an unsymmetrical foil section (e.g., reaction rudder) details of the rudder are to be submitted.

Special attention is to be paid in design and construction of rudders with slender foil sections in the vicinity of their trailing edge (e.g., hollow foil sections, fishtail foil sections). Where the width of the rudder blade at the aftermost vertical diaphragm is equal or less than 1/6 of the trailing edge length measured between the diaphragm and the trailing edge, vibration analysis of the rudder blade is also to be submitted for review.

17.3 Side, Top and Bottom Plating

The plating thickness is not to be less than obtained from the following equation:

$$t = 0.0055s\beta\sqrt{k_1 d + (k_2 C_R / A)} \times \sqrt{Q} + k_3 \text{ mm (in.)}$$

where

$$k_1 = 1.0 \text{ (1.0, 0.305)}$$

$$k_2 = 0.1 \text{ (0.981, 10.7)}$$

$$k_3 = 2.5 \text{ (2.5, 0.1)}$$

$$d = \text{summer loadline draft of the craft, in m (ft)}$$

$$C_R = \text{rudder force according to 3-2-8/3, in kN (tf, Ltf)}$$

$$A = \text{rudder area, in m}^2 \text{ (ft}^2\text{)}$$

$$s = \text{smaller unsupported dimension of plating, in mm (in.)}$$

$$b = \text{greater unsupported dimension of plating, in mm (in.)}$$

$$\beta = \sqrt{1.1 - 0.5(s/b)^2} ; \text{ maximum 1.0 for } b/s \geq 2.5$$

$$Q = \text{material factor for rudder plating, as defined in 3-2-1/1.1.1}$$

The thickness of the rudder side or bottom plating is to be at least 2 mm (0.08 in.) greater than that required by 3-2-3/1.3 with p obtained from 3-2-2/9.1, for which h is measured from the lower edge of the plate to the design load waterline in displacement mode.

17.5 Diaphragm Plates

Vertical and horizontal diaphragms are to be fitted within the rudder, effectively attached to each other and to the side plating. Vertical diaphragms are to be spaced approximately 1.5 times the spacing of horizontal diaphragms. Openings are in general not to be more than 0.5 times the depth of the web.

The thickness of diaphragm plates is not to be less than 70% of the required rudder side plate thickness or 8 mm (0.31 in.) whichever is greater. Openings in diaphragms are not to exceed one half their depth.

Welding is to be in accordance with Section 2-4-1 of the *ABS Rules for Materials and Welding (Part 2)* and Section 3-2-13 of this Guide. Where inaccessible for welding inside the rudder, it is recommended that diaphragms be fitted with flat bars and the side plating be connected to these flat bars by continuous welds or by 75 mm (3 in.) slot welds spaced at 150 mm (6 in.) centers. The slots are to be fillet welded around the edge, and filled with a suitable compound.

17.7 Watertightness

The rudder is to be watertight and is to be tested in accordance with 3-7-1/Table 1.

19 Single Plate Rudders

19.1 Mainpiece Diameter

The mainpiece diameter is calculated according to 3-2-8/7.3. For spade rudders, the lower third may be tapered down to 0.75 times stock diameter at the bottom of the rudder.

19.3 Blade Thickness

The blade thickness is not to be less than obtained from the following equation:

$$t_b = 0.0015sV_R + 2.5 \text{ mm} \qquad t_b = 0.0015sV_R + 0.1 \text{ in.}$$

where

s = spacing of stiffening arms, in mm (in.), not to exceed 1000 mm (39 in.)

V_R = speed, as defined in 3-2-8/3.1

19.5 Arms

The thickness of the arms is not to be less than the blade thickness obtained in 3-2-8/19.3. The section modulus of each set of arms about the axis of the rudder stock is not to be less than obtained from the following equation:

$$SM = 0.0005 sC_1^2V^2 \text{ cm}^3 \qquad SM = 0.0000719 sC_1^2V^2 \text{ in}^3$$

where

C_1 = horizontal distance from the aft edge of the rudder to the centerline of the rudder stock, in m (ft)

Q = as defined in 3-2-1/1.1.1

s, V_R are defined in 3-2-8/19.3.

21 Shelled Rudder Blades

Rudder blades that are constructed out of cast resilient polymers or filled FRP shells are to have a solid metallic core that complies with the requirements for single plate rudders, see 3-2-8/11.

PART 3

CHAPTER 2 Hull Structures and Arrangements

SECTION 9 Protection of Deck Openings

1 General

All openings in decks are to be framed to provide efficient support and attachment for the ends of the deck beams. The proposed arrangement and details for all hatchways are to be submitted for approval.

3 Position of Deck Openings

For the purpose of this Guide, two positions of deck openings are defined as follows:

Position 1 Upon exposed main and raised quarter decks, and upon exposed superstructure decks situated forward of a point located a quarter of the craft length from the forward perpendicular.

Position 2 Upon exposed superstructure decks situated abaft a quarter of the craft length from the forward perpendicular.

5 Hatchway Coamings, Companionway Sills and Access Sills

5.1 Coaming and Sill Heights

The heights above deck of the coamings, the sills of companionways and access openings, are to be not less than given in 3-2-9/Table 1. Where hatch covers are substantially constructed and made tight by means of gaskets and clamping devices, these heights may be reduced, or the coamings omitted entirely, provided that the safety of the craft is not thereby impaired in any sea conditions. Sealing arrangements are to be weathertight if coaming is fitted, and watertight for flush covers.

TABLE 1
Coamings and Sill Heights

<i>L equal to or over 24 meters (79 feet) in length</i>		
	<i>Position 1</i>	<i>Position 2</i>
Hatch Coamings	600 mm (23.5 in.)	450 mm (17.5 in.)
Companionway Sills	600 mm (23.5 in.)	380 mm (15 in.)
Access Sills	380 mm (15 in.)	380 mm (15 in.)
<i>L under 24 meters (79 feet) in length</i>		
	<i>Position 1</i>	<i>Position 2</i>
Hatch Coamings and Companionways	450 mm (17.5 in.)	300 mm (12 in.)
Access Sills	380 mm (15 in.)	300 mm (12 in.)

Note: For craft with $L < 24$ m, the coaming/sill height should be as indicated above.

7 Enclosed Superstructures

To be considered enclosed, superstructures are to meet the following requirements. Superstructures with openings which do not fully comply with these requirements are to be considered as open superstructures. See also 3-2-11/3.7.

7.1 Closing Appliances

All openings in the bulkheads of enclosed superstructures are to be provided with efficient means of closing, so that in any sea conditions water will not penetrate the craft. Opening and closing appliances are to be framed and stiffened so that the whole structure, when closed, is equivalent to the unpierced bulkhead.

Doors for access openings into enclosed superstructures are to be of steel or other approved material, permanently and strongly attached to the bulkhead. The doors are to be provided with gaskets and clamping devices, or other equivalent arrangements, permanently attached to the bulkhead or to the doors themselves, and the doors are to be so arranged that they can be operated from both sides of the bulkhead. The construction of the doors is to be as required in 3-2-5/1.13.

Portlights and windows in the end bulkheads of enclosed superstructures are to be of substantial construction and provided with efficient inside deadlights, as required in 3-2-11/5.

The location and means of the closing appliances for windows are to be in accordance with 3-2-11/7.

7.3 Sills of Access Openings

Except as otherwise provided in this Guide, the height of the sills of access openings in bulkheads at the ends of enclosed superstructures is to be at least 380 mm (15 in.) above the deck. See 3-2-9/Table 1 for required sill heights.

7.5 Means of Access

Superstructures are not to be regarded as enclosed unless access is provided for the crew to reach machinery and other working spaces inside these superstructures by alternate means which are available at all times when bulkhead openings are closed.

9 Hatchways Closed by Covers of Steel and Fitted with Gaskets and Clamping Devices

9.1 Strength of Covers

The maximum allowable stress and deflection under design load, w , and the minimum top plate thickness are as follows:

Maximum allowable stress	$0.235\sigma_u$
Maximum allowable deflection	$0.0028s$
Top plate thickness	$0.01s$, but not less than 6.0 mm (0.24 in.)

Position 1

$w = 0.097L + 7.45$	kN/m ²
$w = 0.0099L + 0.76$	tf/m ²
$w = 0.61L + 158.0$	lbf/ft ²

Position 2

$w = 0.0709L + 5.65$	kN/m ²
$w = 0.00725L + 0.576$	tf/m ²
$w = 0.450L + 118.5$	lbf/ft ²

where

- w = design load, in kN/m² (tf/m², lbf/ft²)
- L = length of craft, in m (ft), as defined in Section 3-1-1, but is not to be taken less than 24 m (79 ft).
- s = stiffener spacing, in mm (in.)
- σ_u = minimum ultimate tensile strength, in N/mm² (kgf/mm², psi)

9.3 Means for Securing Weathertightness

The means for securing and maintaining weathertightness is to be such that the tightness can be maintained in any sea condition. The covers are to be hose tested in position under a water pressure of at least 2.1 bar (2.1 kgf/cm², 30 psi) at the time of installation.

9.5 Flush Hatch Covers

Where flush hatch covers are fitted on the freeboard deck within the forward one-fourth length, and the craft is operating with low freeboard (e.g., assigned a freeboard less than Type-B under the International Convention on Load Lines 1966), the assumed loads on flush hatch covers are to be increased 15% over that indicated in 3-2-9/9.1.

11 Hatchways Closed by Portable Covers in Lower Decks or within Fully Enclosed Superstructures

11.1 General

The following scantlings are intended for conventional type covers. Those for covers of special types are to be specially considered.

11.3 Steel Covers

The thickness of the plating for steel covers is not to be less than required for lower decks as obtained from 3-2-3/1. A stiffening bar is to be fitted around the edges as required to provide the necessary rigidity to permit the covers being handled without deformation. The effective depth of the framework is normally to be not less than 4% of its unsupported length. The stiffeners, in association with the plating to which they are attached, are to have section modulus, SM , as determined by the following equation:

$$SM = 7.8hs\ell^2 \text{ cm}^3 \qquad SM = 0.0041hs\ell^2 \text{ in}^3$$

where

- h = tween-deck height, in m (ft)
- s = spacing of the stiffeners, in m (ft)
- ℓ = length of the stiffener, in m (ft)

11.5 Wheel Loading

Where provision is to be made for the operation and stowage of vehicles having rubber tires, the thickness of the hatch cover plating is to be in accordance with 3-2-3/1.9.

13 Hatchways Closed by Covers of Materials Other Than Steel

Hatch covers constructed of materials other than steel will be specially considered.

15 Small Hatches on the Exposed Fore Deck

15.1 Application

This subsection is applicable to craft with length L (as defined in 3-1-1/3) not less than 80 meters (263 feet).

The requirements of this subsection apply to all small hatches [opening normally 2.5 square meters (27 ft²) or less] located on the exposed fore deck within the forward $0.25L$, where the deck in way of the hatch is less than $0.1L$ or 22 m (72.2 ft) above the summer load line, whichever is less.

Hatches designed for emergency escape need not comply with 3-2-9/15.5i), 3-2-9/15.5ii), the third paragraph of 3-2-9/15.7 and 3-2-9/15.9.

15.3 Strength

For small rectangular steel hatch covers, the plate thickness, stiffener arrangement and scantlings are to be in accordance with 3-2-9/Table 2 and 3-2-9/Figure 1. Stiffeners, where fitted, are to be aligned with the metal-to-metal contact points required in 3-2-9/15.7. See also 3-2-9/Figure 1. Primary stiffeners are to be continuous. All stiffeners are to be welded to the inner edge stiffener, see 3-2-9/Figure 2.

The upper edge of the hatchway coaming is to be suitably reinforced by a horizontal section, normally not more than 170 to 190 mm (6.9 to 7.5 in.) from the upper edge of the coaming.

For small hatch covers of circular or similar shape, the cover plate thickness and reinforcement is to provide strength and stiffness equivalent to the requirements for small rectangular hatches.

For small hatch covers constructed of materials other than steel, the required scantlings are to provide strength and stiffness equivalent to 235 N/mm² (24 kgf/mm², 34 psi) yield strength steel.

15.5 Primary Securing Devices

The primary securing devices are to be such that their hatch covers can be secured in place and made weather-tight by means of a mechanism employing any one of the following methods:

- i) Butterfly nuts tightening onto forks (clamps), or
- ii) Quick acting cleats, or
- iii) A central locking device.

Dogs (twist tightening handles) with wedges are not acceptable.

15.7 Requirements for Primary Securing

The hatch cover is to be fitted with a gasket of elastic material. This is to be designed to allow a metal-to-metal contact at a designed compression and to prevent over compression of the gasket by green sea forces that may cause the securing devices to be loosened or dislodged. The metal-to-metal contacts are to be arranged close to each securing device in accordance with 3-2-9/Figure 1, and of sufficient capacity to withstand the bearing force.

The primary securing method is to be designed and manufactured such that the designed compression pressure is achieved by one person without the need of any tools.

For a primary securing method using butterfly nuts, the forks (clamps) are to be of robust design. They are to be designed to minimize the risk of butterfly nuts being dislodged while in use; by means of curving the forks upward and a raised surface on the free end, or a similar method. The plate thickness of unstiffened steel forks is not to be less than 16 mm. An example arrangement is shown in 3-2-9/Figure 2.

For small hatch covers located on the exposed deck forward of the fore-most cargo hatch, the hinges are to be fitted such that the predominant direction of green sea will cause the cover to close, which means that the hinges are normally to be located on the fore edge.

On small hatches located between the main hatches, for example between Nos. 1 and 2, the hinges are to be placed on the fore edge or outboard edge, whichever is practicable for protection from green water in beam sea and bow quartering conditions.

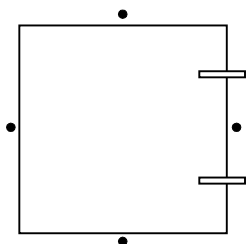
15.9 Secondary Devices

Small hatches on the fore deck are to be fitted with an independent secondary securing device e.g., by means of a sliding bolt, a hasp or a backing bar of slack fit, which is capable of keeping the hatch cover in place, even in the event that the primary securing device became loosened or dislodged. It is to be fitted on the side opposite to the hatch cover hinges.

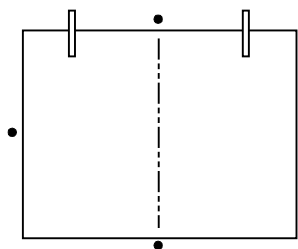
TABLE 2
Scantlings for Small Steel Hatch Covers on the Fore Deck

Nominal Size (mm × mm)	Cover Plate Thickness (mm)	Primary Stiffeners	Secondary Stiffeners
		Flat Bar (mm × mm); number	
630 × 630	8	---	---
630 × 830	8	100 × 8; 1	---
830 × 630	8	100 × 8; 1	---
830 × 830	8	100 × 10; 1	---
1030 × 1030	8	120 × 12; 1	80 × 8; 2
1330 × 1330	8	150 × 12; 2	100 × 10; 2

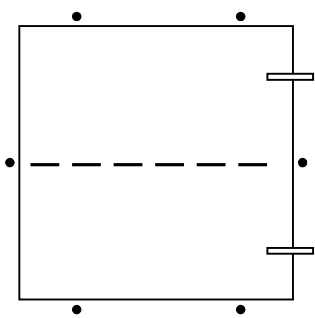
FIGURE 1
Arrangement of Stiffeners



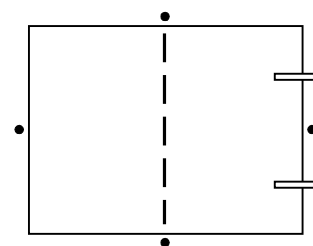
Nominal size 630 × 630



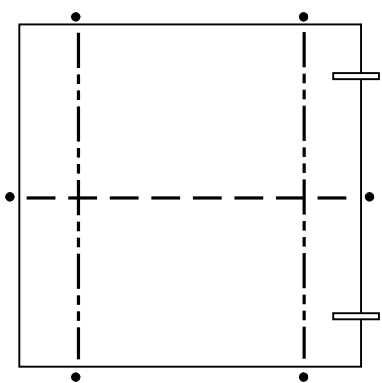
Nominal size 630 × 830



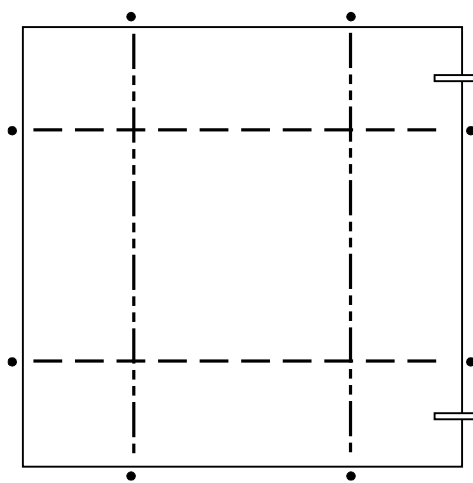
Nominal size 830 × 830



Nominal size 830 × 630



Nominal size 1030 × 1030



Nominal size 1330 × 1330

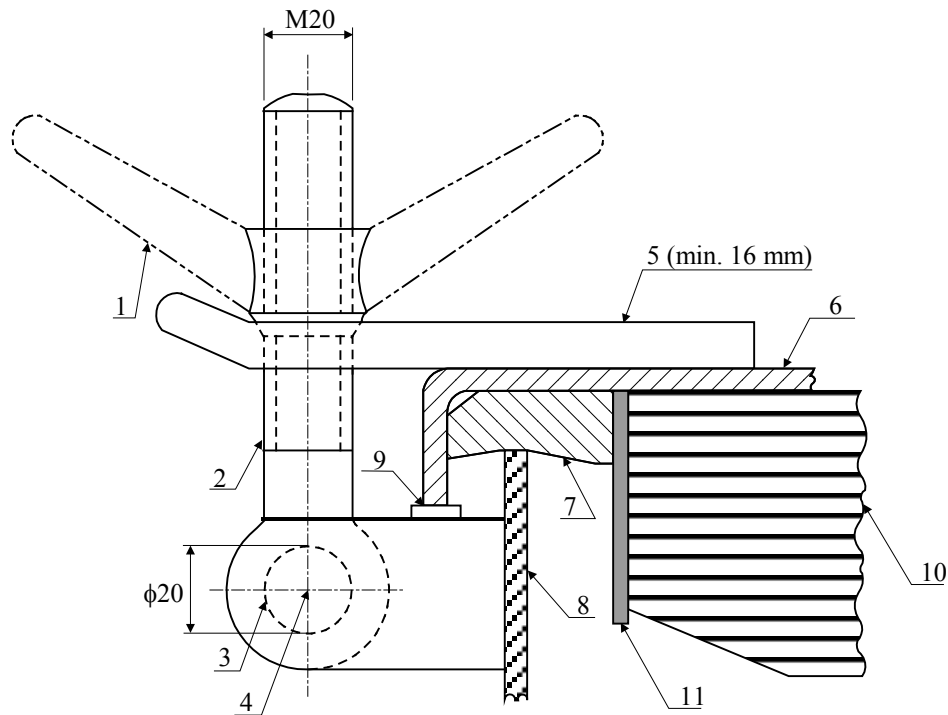
— Hinge

• Securing device/metal to metal contact

— — — Primary stiffener

— — — Secondary stiffener

FIGURE 2
Example of Primary Securing Method



- (Note: Dimensions in millimeters)
- 1: butterfly nut
 - 2: bolt
 - 3: pin
 - 4: center of pin
 - 5: fork (clamp) plate
 - 6: hatch cover
 - 7: gasket
 - 8: hatch coaming
 - 9: bearing pad welded on the bracket of a toggle bolt for metal to metal contact
 - 10: stiffener
 - 11: inner edge stiffener

17 Hatchways within Open Superstructures

Hatchways within open superstructures are to be considered as exposed.

19 Hatchways within Deckhouses

Hatchways within deckhouses are to have coamings and closing arrangements as required in relation to the protection afforded by the deckhouse from the standpoint of its construction and the means provided for the closing of all openings into the house.

21 Machinery Casings

21.1 Arrangement

Machinery-space openings in Position 1 or 2 are to be framed and efficiently enclosed by casings of ample strength, and wherever practicable, those in main decks are to be within superstructures or deckhouses. Casings are to be of material similar to that of the surrounding structure. Openings in exposed casings are to be fitted with doors complying with the requirements of 3-2-9/7.1; the sills are to be in accordance with 3-2-9/5.1 for companionways. Other openings in such casings are to be fitted with equivalent covers, permanently attached. Stiffeners are to be spaced at not more than 760 mm (30 in.)

21.3 Scantlings

The scantlings of exposed casings are to be similar to those obtained for superstructures and deckhouses in accordance with the applicable requirements of Sections 3-2-2, 3-2-3 and 3-2-4.

The scantlings of casings within enclosed superstructures or deckhouses will be specially considered.

23 Miscellaneous Openings in Freeboard and Superstructure Decks

23.1 Manholes and Scuttles

Manholes and flush scuttles in Position 1 or 2 within superstructures other than enclosed superstructures are to be closed by substantial covers capable of being made watertight. Unless secured by closely spaced bolts, the covers are to be permanently attached.

23.3 Other Openings

Openings in freeboard decks other than hatchways, machinery-space openings, manholes and flush scuttles are to be protected by an enclosed superstructure, or by a deckhouse or companionway of equivalent strength and weathertightness. Any such opening in an exposed superstructure deck or in the top of a deckhouse on the main deck which gives access to a space below the main deck or a space within an enclosed superstructure is to be protected by an efficient deckhouse or companionway. Doorways in such deckhouses or companionways are to be fitted with doors complying with the requirements given in 3-2-9/7.1.

23.5 Escape Openings (1 July 2012)

- i) The closing appliances of escape openings are to be of a type that is operable from each side.
- ii) The maximum force needed to open the hatch cover is not to exceed 150 N (15.3 kgf, 33.7 lbf).
- iii) The use of a spring equalizing, counterbalance or other suitable device on the hinge side to reduce the force needed for opening is acceptable.

23.7 Chain Pipe Opening (1 July 2012)

For craft with length L (as defined in 3-1-1/3) greater than 24 meters (79 feet), chain pipes through which anchor cables are led are to be provided with permanently attached closing appliances to minimize ingress of water. A canvas cover with appropriate lashing arrangement will be acceptable* for this purpose. Cement and wire mesh arrangement is not permitted.

The arrangement on craft that are not subject to the International Convention on Load Lines or its Protocol may be specially considered.

* Note: Examples of acceptable arrangements are such as:

- i) Steel plates with cutouts to accommodate chain links or
- ii) Canvas hoods with a lashing arrangement that maintains the cover in the secured position.

CHAPTER 2 Hull Structures and Arrangements**SECTION 10 Protection of Shell Openings****1 Cargo, Gangway, or Fueling Ports****1.1 Construction**

Cargo, gangway, or fueling ports in the sides of craft are to be strongly constructed and capable of being made thoroughly watertight. Where frames are cut in way of such ports, web frames are to be fitted on the sides of the openings, and suitable arrangements are to be provided for the support of the beams over the openings. Thick shell plates or doublers are to be fitted as required to compensate for the openings. The corners of the openings are to be well rounded. Waterway angles and scuppers are to be provided on the decks in way of ports in cargo spaces below the freeboard deck or in cargo spaces within enclosed superstructures to prevent the spread of any leakage water over the decks.

Indicators showing whether the ports in the side shell below the freeboard or superstructure deck are secured closed or open are to be provided on the navigation bridge.

1.3 Location

The lower edges of cargo, gangway, or fueling-port openings are not to be below a line parallel to the main deck at side having as its lowest point the designed load waterline or upper edge of the uppermost load line.

3 Bow Doors, Inner Doors, Side Shell Doors and Stern Doors**3.1 General**

Where steel bow doors of the visor or side-opening type are fitted leading to complete or long forward enclosed superstructure, bow doors and inner doors are to meet the requirements of this section. Hull supporting structure in way of the bow doors is to be able to withstand the loads imposed by the bow doors securing and supporting devices without exceeding the allowable stresses for those devices, both given in this section. Special consideration will be given to bow doors constructed of materials other than steel.

3.3 Arrangement**3.3.1 General**

As far as practicable, bow doors and inner doors are to be arranged so as to preclude the possibility of the bow door causing structural damage to the inner door or to the collision bulkhead in the case of damage to or detachment of the bow door.

3.3.2 Bow Doors

Bow doors are to be situated above the main deck except that where a watertight recess fitted for arrangement of ramps or other related mechanical devices is located forward of the collision bulkhead and above the deepest waterline, the bow doors may be situated above the recess.

3.3.3 Inner Doors

An inner door is to be fitted in the extension of the collision bulkhead required by 3-2-5/1.3. A vehicle ramp made watertight and conforming to 3-2-5/1.3 in the closed position may be accepted for this purpose.

3.3.4 Side Shell and Stern Doors

Stern doors for passenger craft are to be situated above the freeboard deck. Stern doors for ro-ro cargo craft and all side shell doors need not be situated above the freeboard deck.

5 Securing, Locking and Supporting of Doors

5.1 Definitions

5.1.1 Securing Device

A device used to keep the door closed by preventing it from rotating about its hinges or its pivoted attachments to the craft.

5.1.2 Supporting Device

A device used to transmit external or internal loads from the door to a securing device and from the securing device to the craft's structure, or a device other than a securing device, such as a hinge, stopper or other fixed device, that transmits loads from the door to the craft's structure.

5.1.3 Locking Device

A device that locks a securing device in the closed position.

7 Securing and Supporting Devices

7.1 General

Securing and supporting devices are to be arranged in accordance with this subsection, and are to have scantlings as required by 3-2-10/13.9, 3-2-10/15.5 or 3-2-10/17.9, as appropriate.

7.3 Bow Doors

Means are to be provided to prevent lateral or vertical movement of the bow doors when closed. Means are also to be provided for mechanically fixing the door in the open position.

Means of securing and supporting the door are to maintain equivalent strength and stiffness of the adjacent structure.

7.3.1 Clearance and Packing

The maximum design clearance between the door and securing/supporting devices is not to exceed 3 mm (0.12 in.). Where packing is fitted, it is to be of a comparatively soft type and the supporting forces are to be carried by the steel structure only.

7.3.2 Visor Door Arrangement

The pivot arrangement is to be such that the visor is self closing under external loads. The closing moment, M_{yo} , as defined in 3-2-10/19.5.1 is not to be less than M_{yo} as given by the following equation:

$$M_{yo} = Wc + 0.1 \sqrt{a^2 + b^2} \sqrt{F_x^2 + F_z^2}$$

where W , a , b , c , F_x and F_z are as defined in 3-2-10/19.

In addition, the arrangement of the door is to be such that the reaction forces of pin or wedge supports at the base of the door does not act in the forward direction when the door is loaded in accordance with 3-2-10/19.5.4.

7.5 Side Shell and Stern Doors

Means are to be provided to prevent lateral or vertical movement of the side shell or stern doors when closed. Means are also to be provided for mechanically fixing the doors in the open position.

The means of securing and supporting the doors are to have strength and stiffness equivalent to the adjacent structure.

Clearance and packing for side shell and stern doors are to be in accordance with 3-2-10/7.3.1.

9 Securing and Locking Arrangement

9.1 General

Securing devices are to be provided with a mechanical locking arrangement (self locking or separate arrangement), or are to be of the gravity type.

9.3 Operation

Securing devices are to be simple to operate and readily accessible. The opening and closing systems as well as the securing and locking devices are to be interlocked in such a way that they can only operate in the proper sequence.

9.3.1 Hydraulic Securing Devices

Where hydraulic securing devices are applied, the system is to be mechanically lockable in the closed position. In the event of a loss of hydraulic fluid, the securing devices are to remain locked.

The hydraulic system for securing and locking devices is to be isolated from other hydraulic circuits when in the closed position.

9.3.2 Remote Control

Where bow doors and inner doors give access to a vehicle deck, an arrangement for remote control from a position above the freeboard deck is to be provided allowing closing and opening of the doors and associated securing and locking of the securing and locking devices for every door. The operating panels for operation of doors are to be accessible to authorized persons only. A notice plate giving instructions to the effect that all securing devices are to be closed and locked before leaving harbor is to be placed at each operating panel and is to be supplemented by warning indicator lights as indicated in 3-2-10/9.5.1.

9.5 Indication/Monitoring

9.5.1 Indicators

The indicator system is to be designed on the fail safe principle and in accordance with the following:

9.5.1(a) Location and Type. Separate indicator lights are to be provided on the navigation bridge to show that the bow door and inner door are closed and that their locking devices are properly positioned.

The indication panel on the navigation bridge is to be equipped with a mode selection function "harbor/sea voyage", arranged so that an audible and visible alarm is given if in the sea voyage condition, the bow door or inner door is not closed, or any of the securing devices is not in the correct position.

Indication of the open/closed position of every door and every securing and locking device is to be provided at the operating panels.

9.5.1(b) Indicator lights. Indicator lights are to be designed so that they cannot be manually turned off. The indication panel is to be provided with a lamp test function.

9.5.1(c) Power Supply. The power supply for the indicator system is to be independent of the power supply for operating and closing the doors.

9.5.1(d) Protection of Sensors. Sensors are to be protected from water, ice formation and mechanical damage.

9.5.2 Water Leakage Protection

A drainage system is to be arranged in the area between the bow door and ramp and in the area between the ramp and inner door where fitted. The system is to be equipped with an audible alarm function to the navigation bridge for water level in these areas exceeding 0.5 m (1.6 ft) above the car deck level.

A water leakage detection system with audible alarm and television surveillance are to be arranged to provide an indication to the navigation bridge and to the engine control room of leakage through the inner door.

9.5.3 Door Surveillance

Between the bow door and the inner door a television surveillance system is to be fitted with a monitor on the navigation bridge and in the engine control room. The system is to monitor the position of doors and a sufficient number of their securing devices.

11 Tightness

11.1 Bow Doors

Bow doors are to be so fitted as to ensure tightness consistent with operational conditions and to give effective protection to the inner doors.

11.3 Inner Doors

Inner doors forming part of the extension of the collision bulkhead are to be weathertight over the full height of the cargo space and arranged with fixed sealing supports on the aft side of the doors.

11.5 Side Shell and Stern Doors

Side shell doors and stern doors are to be so fitted as to ensure watertightness.

13 Bow Door Scantlings

13.1 General

Bow doors are to be framed and stiffened so that the whole structure is equivalent to the unpierced bulkhead when closed.

13.3 Primary Structure

Scantlings of primary members are to be designed so that the allowable stresses indicated in 3-2-10/25.1 are not exceeded when the structure is subjected to the design loads indicated in 3-2-10/19.1. Unless the ends of the primary members are effectively fixed-ended, the member is to be considered simply supported.

13.5 Secondary Stiffeners

Secondary stiffeners are to be supported by primary members constituting the main stiffening of the door. The section modulus, SM , of secondary stiffeners is to be as required by 3-2-4/1.3. In addition, stiffener webs are to have a net sectional area not less than that obtained from the following equation:

$$A = VQ/10 \text{ cm}^2 \quad (A = VQ \text{ cm}^2, A = VQ/6.5 \text{ in}^2)$$

where

V = shear force, in kN (tf, Ltf), in the stiffener calculated using the uniformly distributed external pressure P_{eb} given in 3-2-10/19.1

Q = as defined in 3-2-1/1.1.1

13.7 Plating

The thickness of bow door plating is to be not less than that required for side shell plating at the same location.

13.9 Securing and Supporting Devices

Scantlings of securing and supporting devices are to be designed so that the allowable stresses indicated in 3-2-10/25.1 are not exceeded when the structure is subjected to the design loads indicated in 3-2-10/19.3. All load transmitting elements in the design load path from the door through securing and supporting devices into the craft structure, including welded connections, are to meet the strength standards required for securing and supporting devices. Where fitted, threaded bolts are not to carry support forces, and the maximum tensile stress in way of the threads is not to exceed the allowable stress given in 3-2-10/25.5.

In determining the required scantlings, the door is to be assumed to be a rigid body. Only those active supporting and securing devices having an effective stiffness in the relevant direction are to be included and considered when calculating the reaction forces on the devices. Small or flexible devices such as cleats intended to provide load compression of the packing material are not to be included in the calculations.

13.9.1 Bearing Pressure

The bearing pressure on steel to steel bearings is to be calculated by dividing the design force by the projected bearing area, and is not to exceed the allowable stress given in 3-2-10/25.3.

13.9.2 Redundancy

In addition to the above requirements, the arrangement of the securing and supporting devices is to be designed with redundancy such that in the event of failure of any single securing or supporting device, the stresses in the remaining devices do not exceed the allowable stresses indicated in 3-2-10/25.1 by more than 20% under the above loads.

13.9.3 Visor Door Securing and Supporting Devices

Securing and supporting devices, excluding the hinges, are to be capable of resisting the vertical design force given in 3-2-10/19.5.3 without stresses exceeding the allowable stresses in 3-2-10/25.1.

Two securing devices are to be provided at the lower part of the door, each capable of providing the full reaction force required to prevent opening of the door without stresses exceeding the allowable stresses indicated in 3-2-10/25.1. The opening moment, M_o , to be balanced by this force is as given in 3-2-10/19.5.2.

13.9.4 Side-opening Door Thrust Bearing

A thrust bearing is to be provided in way of girder ends at the closing of the two doors, and is to prevent one door from shifting towards the other one under the effect of unsymmetrical pressure. Securing devices are to be fitted to secure sections thrust bearing to one another.

13.11 Visor Door Lifting Arms and Supports

Where visor type bow doors are fitted, calculations are to be submitted verifying that lifting arms and their connections to the door and craft structure are adequate to withstand the static and dynamic forces applied during the lifting and lowering operations under a wind pressure of at least 1.5 kN/m² (0.15 tf/m², 0.014 Ltf/ft²)

15 Inner Door Scantlings

15.1 General

Scantlings of inner doors are to meet the requirements of this Subsection. In addition, where inner doors are used as vehicle ramps, scantlings are not to be less than required for vehicle decks.

15.3 Primary Structure

Scantlings of primary members are to be designed so that the allowable stresses indicated in 3-2-10/25.1 are not exceeded when the structure is subjected to the design loads indicated in 3-2-10/21.1.

15.5 Securing and Supporting Devices

Scantlings of securing and supporting devices are to be designed so that the allowable stresses indicated in 3-2-10/25.1 are not exceeded when the structure is subjected to the design loads indicated in 3-2-10/21.1. Where fitted, threaded bolts are not to carry support forces, and the maximum tensile stress in way of the threads is not to exceed the allowable stress given in 3-2-10/25.5.

The bearing pressure on steel to steel bearings is to be calculated by dividing the design force by the projected bearing area, and is not to exceed the allowable stress given in 3-2-10/25.3.

17 Side Shell Door and Stern Door Scantlings

17.1 General

Scantlings of side shell doors or stern doors are to meet the requirements of this subsection. The doors are to be framed and stiffened so that the whole structure is equivalent to the intact side or stern structure when closed. In addition, where the doors are used as vehicle ramps, scantlings are not to be less than required for vehicle decks in Sections 3-2-3 and 3-2-4.

17.3 Primary Structure

Scantlings of primary members are to be designed so that the allowable stresses indicated in 3-2-10/25.1 are not exceeded when the structure is subjected to the design loads indicated in 3-2-10/23. The primary members are to be considered simply supported at their support points unless the end connections are effectively restrained.

17.5 Secondary Stiffeners

Secondary stiffeners are to be supported by primary members constituting the main stiffening of the door. The section modulus, SM , of secondary stiffeners is to be not less than required by Section 3-2-4 for frames in the same location. In addition, the net sectional area of stiffener webs is to be in accordance with 3-2-10/13.5, using the external pressure, p_e , given in 3-2-10/23.

17.7 Plating

The thickness of side or stern door plating is to be not less than that required for side shell plating at the same location.

17.9 Securing and Supporting Devices

Scantlings of securing and supporting devices are to be designed so that the allowable stresses indicated in 3-2-10/25.1 are not exceeded when the structure is subjected to the design loads indicated in 3-2-10/23. All load-transmitting elements in the design load path from the door through securing and supporting devices into the craft structure, including welded connections, are to meet the strength standards required for securing and supporting devices. Where fitted, threaded bolts are not to carry support forces, and the maximum tensile stress in way of the threads is not to exceed the allowable stress given in 3-2-10/25.5.

In determining the required scantlings, the door is to be assumed to be a rigid body. Only those active supporting and securing devices having an effective stiffness in the relevant direction are to be included and considered when calculating the reaction forces on the devices. Small or flexible devices such as cleats intended to provide compression load on the packing material are not to be included in the calculations.

17.9.1 Bearing Pressure

The bearing pressure on steel to steel bearings is to be calculated by dividing the design force by the projected bearing area, and is not to exceed the allowable stress given in 3-2-10/25.3.

17.9.2 Redundancy

In addition to the above requirements, the arrangement of the securing and supporting devices is to be designed with redundancy such that in the event of a failure of any single securing or supporting device, the stresses in the remaining devices do not exceed the allowable stresses indicated in 3-2-10/25.1 by more than 20% under the above loads.

19 Bow Door Design Loads

19.1 External Pressure

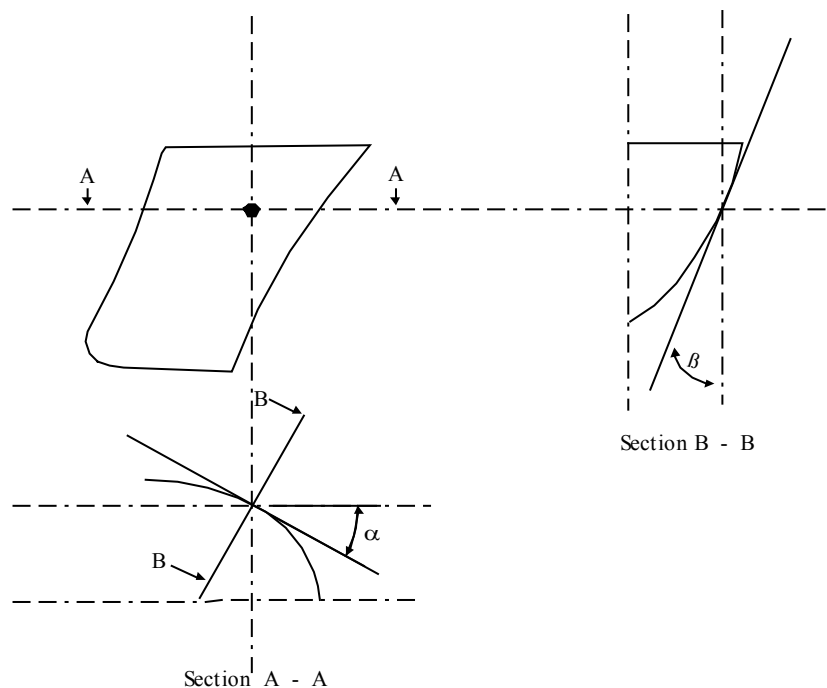
The design external pressure, P_{eb} , is to be taken as indicated by the following equation.

$$P_{eb} = nc (0.22 + 0.15 \tan \beta) (0.4V_d \sin \alpha + 0.6 \sqrt{kL_1})^2 \text{ kN/m}^2 \text{ (tf/m}^2 \text{, Ltf/ft}^2 \text{)}$$

where

- n = 2.75 (0.280, 0.0256)
- c = 0.0125 L for craft having $L < 80$ m (260 ft)
 = 1.0 for other craft
- L = length of craft as defined in 3-1-1/3, in m (ft)
- β = flare angle at the point to be considered, defined as the angle between a vertical line and the tangent to the side shell plating measured in a vertical plane normal to the horizontal tangent to the shell plating. See 3-2-10/Figure 1.
- α = entry angle at the point to be considered, defined as the angle between a longitudinal line parallel to the centerline and the tangent to the shell plating in a horizontal plane. See 3-2-10/Figure 1.
- k = 1.0 (1.0, 0.305)
- V_d = craft design speed as defined in 3-2-8/3.1

FIGURE 1
Entry and Flare Angles



19.3 External Forces

The design external forces considered in determining scantlings of securing and supporting devices of bow doors are not to be taken less than those given by the following equations:

$$F_x = P_{em} A_x$$

$$F_y = P_{em} A_y$$

$$F_z = P_{em} A_z$$

where

F_x = design external force in the longitudinal direction, in kN (tf, Ltf)

F_y = design external force in the horizontal direction, in kN (tf, Ltf)

F_z = design external force in the vertical direction, in kN (tf, Ltf)

A_x = area, in m² (ft²), of the transverse vertical projection of the door between the levels of the bottom of the door and the upper deck or between the bottom of the door and the top of the door, whichever is less.

A_y = area, in m² (ft²), of the longitudinal vertical projection of the door between the levels of the bottom of the door and the upper deck or between the bottom of the door and the top of the door, whichever is less.

A_z = area, in m² (ft²), of the horizontal projection of the door between the levels of the bottom of the door and the upper deck or between the bottom of the door and the top of the door, whichever is less.

P_{em} = bow door pressure, P_{eb} , determined using α_m and β_m in place of α and β .

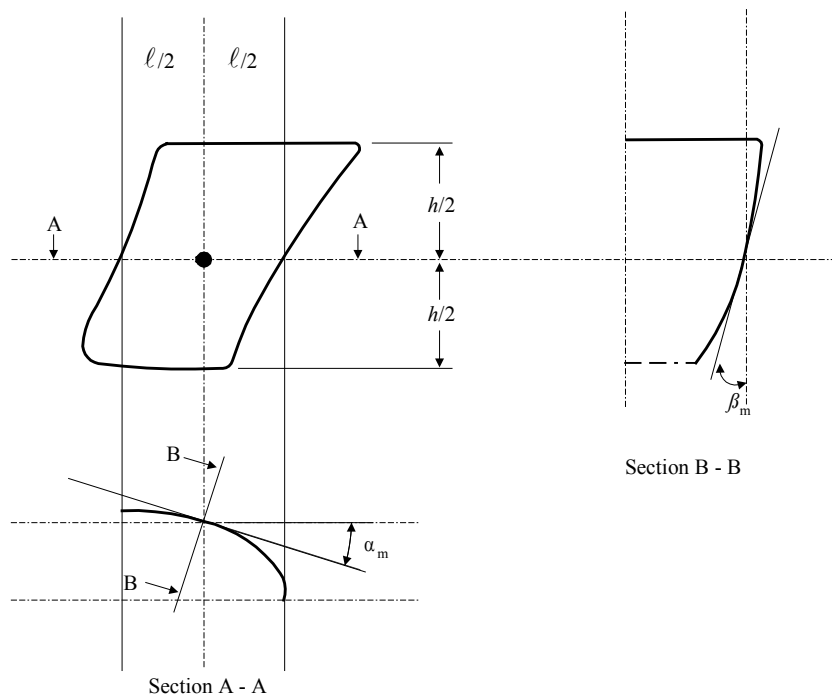
β_m = flare angle measured at a point on the bow door $\ell/2$ aft of the stem line on a plane $h/2$ above the bottom of the door, as shown in 3-2-10/Figure 2.

α_m = entry angle measured at the same point as β_m . See 3-2-10/Figure 2.

h = height, in m (ft), of the door between the levels of the bottom of the door and the upper deck or between the bottom of the door and the top of the door, whichever is less.

ℓ = length, in m (ft), of the door at a height of $h/2$ above the bottom of the door.

FIGURE 2
 Definition of α_m and β_m



19.5 Visor Door Forces, Moments and Load Cases

19.5.1 Closing Moment

For visor doors, the closing moment, M_y , is to be taken as indicated by the following equation:

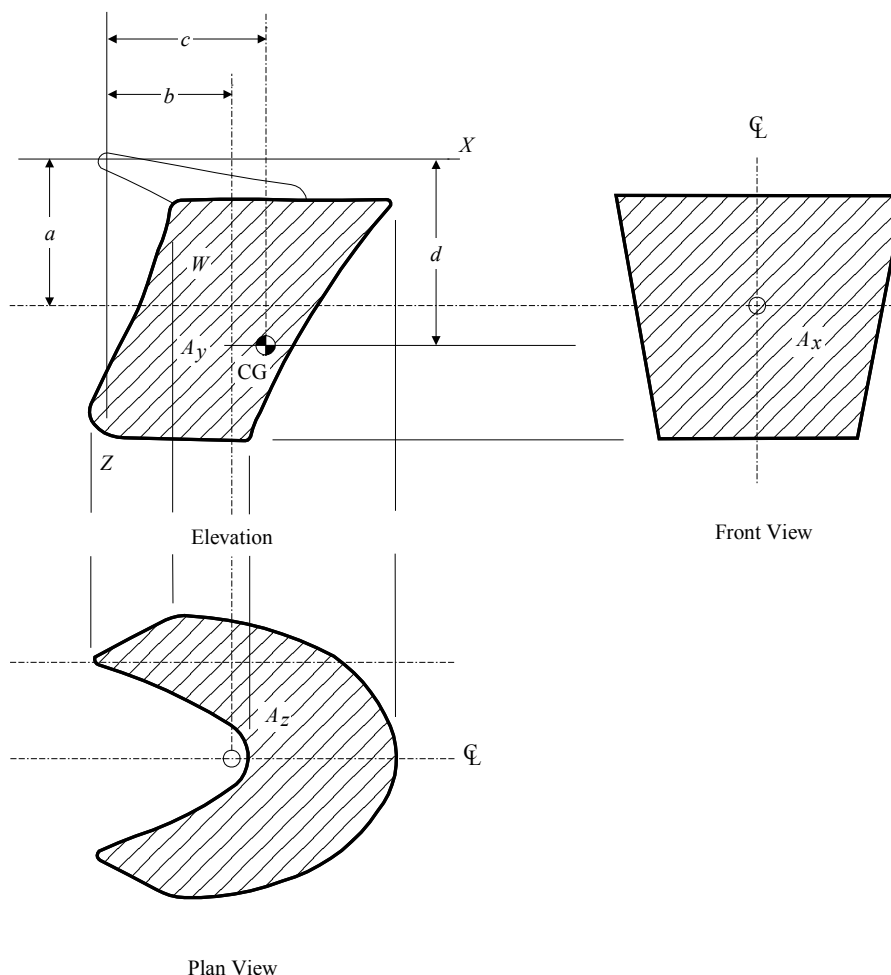
$$M_y = F_x a + Wc - F_z b \quad \text{kN-m (tf-m, Ltf-ft)}$$

where

- W = weight of the visor door, in kN (tf, Ltf)
- a = vertical distance, in m (ft), from the visor pivot to the centroid of the transverse vertical projected area of the visor door. See 3-2-10/Figure 3.
- b = horizontal distance, in m (ft), from visor pivot to the centroid of the horizontal projected area of the visor door. See 3-2-10/Figure 3.
- c = horizontal distance, in m (ft), from the visor pivot to the center of gravity of the visor. See 3-2-10/Figure 3.

F_x and F_z are as defined in 3-2-10/19.3.

FIGURE 3
Visor Type Bow Door



19.5.2 Opening Moment

The opening moment, M_o , is to be taken as indicated by the following equation:

$$M_o = Wd + 5A_x a \text{ kN-m} \quad (Wd + 0.5A_x a \text{ tf-m, } Wd + 0.047A_x a \text{ Ltf-ft})$$

where

d = vertical distance, in m (ft), from the hinge axis to the center of gravity of the door

W , A_x and a are as indicated above.

19.5.3 Vertical Design Force

The vertical design force is to be taken as $F_z - W$, where F_z is as defined in 3-2-10/19.3 and W is as defined in 3-2-10/19.5.1.

19.5.4 Combined Load Case 1

The visor doors are to be evaluated under a load of F_x , F_z and W acting simultaneously with F_x and F_z acting at the centroid of their respective projected areas.

19.5.5 Combined Load Case 2

The visor doors are to be evaluated under a load of $0.7F_y$ acting on each side separately together with $0.7F_x$, $0.7F_z$ and W . F_x , F_y and F_z are to be taken as acting at the centroid of their respective projected areas.

19.7 Side-Opening Door Load Cases

19.7.1 Combined Load Case 1

Side opening doors are to be evaluated under a load of F_x , F_y , F_z and W acting simultaneously with F_x , F_y and F_z acting at the centroid of their respective projected areas.

19.7.2 Combined Load Case 2

Side opening doors are to be evaluated under a load of $0.7F_x$, $0.7F_z$ and W acting on both doors simultaneously and $0.7F_y$ acting on each door separately.

21 Inner Door Design Loads

21.1 External Pressure

The design external pressure is to be taken as the greater of P_{ei} or P_h as given by the following equations:

$$P_{ei} = 0.45L_1 \text{ kN/m}^2 \text{ (0.046}L_1 \text{ tf/m}^2, 0.00128L_1 \text{ Ltf/ft}^2)$$

$$P_h = 10h \text{ kN/m}^2 \text{ (1.0}h \text{ tf/m}^2, 0.029h \text{ Ltf/ft}^2)$$

where

L_1 = as defined in 3-1-1/3.

h = the distance, in m (ft), from the load point to the top of the cargo space.

21.3 Internal Pressure

The design internal pressure, P_i , is to be taken as not less than 25 kN/m^2 (2.5 tf/m^2 , 0.23 Ltf/ft^2).

23 Side Shell and Stern Doors

23.1 Design Forces for Primary Members

The design force, in kN (tf, Ltf), for primary members is to be the greater of the following:

External force: $F_e = A p_e$

Internal force: $F_i = F_o + W$

23.3 Design Forces for Securing or Supporting Devices of Doors Opening Inwards

The design force, in kN (tf, Ltf), for securing or supporting devices of doors opening inwards is to be the greater of the following:

External force: $F_e = A p_e + F_p$

Internal force: $F_i = F_o + W$

23.5 Design Forces for Securing or Supporting Devices of Doors Opening Outwards

The design force, in kN (tf, Ltf), for securing or supporting devices of doors opening outwards is to be the greater of the following:

External force: $F_e = A p_e$

Internal force: $F_i = F_o + W + F_p$

where

A = area, in m^2 (ft^2), of the door opening

W = weight of the door, in kN (tf, Ltf)

- F_p = total packing force, in kN (tf, Ltf). Packing line pressure is normally not to be taken less than 5.0 N/mm (0.51 kg/mm, 28.6 lbf/in).
- F_o = the greater of F_c and kA , in kN (tf, Ltf)
 $k = 5$ (0.51, 0.047)
- F_c = accidental force, in kN (tf, Ltf), due to loose cargo, etc., to be uniformly distributed over the area A and not to be taken less than 300 kN (30.6 tf, 30.1 Ltf). For small doors such as bunker doors and pilot doors, the value of F_c may be appropriately reduced. However, the value of F_c may be taken as zero provided an additional structure such as an inner ramp is fitted which is capable of protecting the door from accidental forces due to loose cargoes.
- p_e = external design pressure, in kN/m² (tf/m², Ltf/ft²), determined at the center of gravity of the door opening and not taken less than:
- $$p_e = k_1 \quad \text{for } Z_G \geq d$$
- $$p_e = k_2 (d - Z_G) + k_1 \quad \text{for } Z_G < d$$
- Moreover, for craft fitted with bow doors, p_e for stern doors is not to be taken less than:
- $$p_e = nc(0.8 + 0.6(k_3L)^{0.5})^2$$
- For craft fitted with bow doors and operating in restricted service, the value of p_e for stern doors will be specially considered.
- k_1 = 25.0 (2.55, 0.233)
- k_2 = 10.0 (1.02, 0.0284)
- d = draft, in m (ft), as defined in 3-1-1/9
- Z_G = height of the center of area of the door, in m (ft), above the baseline.
- n = 0.605 (0.0616, 0.00563)
- k_3 = 1.0 (1.0, 0.305)
- c = 0.0125L for $L < 80$ m (262 ft)
 = 1 for $L \geq 80$ m (262 ft)
- L = length of craft, in m (ft), as defined in 3-1-1/3, but need not be taken as greater than 200 m (656 ft).

25 Allowable Stresses

25.1 Primary Structure and Securing and Supporting Devices

The following stresses are not to be exceeded under the loads indicated above:

Shear Stress: $\tau = 80/Q$ N/mm² (8.2/ Q kgf/mm², 11600/ Q psi)

Bending Stress: $\sigma = 120/Q$ N/mm² (12.2/ Q kgf/mm², 17400/ Q psi)

Equivalent Stress: ($\sqrt{\sigma^2 + 3\tau^2}$): $\sigma_e = 150/Q$ N/mm² (15.3/ Q kgf/mm², 21770/ Q psi)

where Q is defined in 3-2-1/1.1.1.

25.3 Steel Securing and Supporting Devices Bearing Stress

For steel to steel bearings in securing and supporting devices, the nominal bearing pressure is not to exceed $0.8\sigma_f$, where σ_f is the yield stress of the bearing material.

25.5 Tensile Stress on Threaded Bolts

The tensile stress in threaded bolts is not to exceed $125/Q$ N/mm² ($12.7/Q$ kgf/mm², 18,000/ Q psi).

27 Operating and Maintenance Manual

The following information is to be submitted for review:

27.1 Manual

An operating and maintenance manual for the bow door and inner door is to be provided on board and is to contain at least the following:

- Main particulars and design drawings
- Service conditions (e.g., service area)
- Restrictions, acceptable clearances for supports
- Maintenance and function testing
- Register of inspections and repairs

27.3 Operating Procedures

Documented operating procedures for closing and securing the bow door and inner door are to be kept on board and posted at an appropriate location.

PART

3

CHAPTER **2 Hull Structures and Arrangements**

SECTION **11 Bulwarks, Rails, Ports, Portlights, Windows, Ventilators, Tank Vents and Overflows**

1 Bulwarks and Guard Rails

Bulwarks or guard rails or a combination of both, are in general to be provided on periphery of exposed decks, and on exposed tops of superstructures and deckhouses.

Where the flag administration has specific requirements for bulwarks and guardrails they may be accepted provided they are not less effective.

For vessels less than 24 meters (79 ft) in length, may be special considered.

1.1 Location and Heights

Bulwarks or guardrails are also to be provided on the exposed side of any platform surface that is greater than 600 mm (24 in.) or higher above the adjacent surface.

The height of bulwarks and guard rails on exposed freeboard and superstructure decks is to be at least 1 m (39.5 in.). Where this height would interfere with the normal service or operation of a craft, a lesser height may be approved if adequate protection is provided. Where approval of a lesser height is requested, justifying information is to be submitted, such as arrangements provided to prevent personnel going over the guard rails or bulwarks.

1.3 Strength of Bulwarks

Bulwarks are to be of ample strength for their height and location, suitably stiffened at the top, and if necessary at the bottom, and supported by efficient stays or brackets.

Stays or brackets on the main weather deck are to be spaced not more than 1.83 m (6.0 ft).

Openings in bulwarks are to be smooth-edged, with well-rounded corners.

1.5 Guard Rails

1.5.1

Fixed, removable or hinged stanchions are to be fitted at approximately 1.5 m (5 ft) apart. Removable or hinged stanchions are to be capable of being locked in the upright position.

1.5.2

At least every third stanchion is to be supported by a bracket or stay. Dimensions and arrangement of stanchion and stays are to be as shown in 3-2-11/Figure 1. Where this arrangement would interfere with the safe traffic of persons on board, the following alternative arrangements of stanchions may be acceptable:

- i)* At least every third stanchion is to be of increased breadth, $kb_s = 2.9b_s$ at the attachment of stanchion to the deck, or,
- ii)* At least every second stanchion is to be of increased breadth, $kb_s = 2.4b_s$ at the attachment of stanchion to the deck, or,

iii) Every stanchion is to be of increased breadth, $kb_s = 1.9b_s$ at the attachment of stanchion to the deck.

where, b_s is not to be taken as less than 60 mm (2.36 in.) (see 3-2-11/Figure 2). The thickness of the flat bar stanchions is not to be less than 15 mm (0.59 in.).

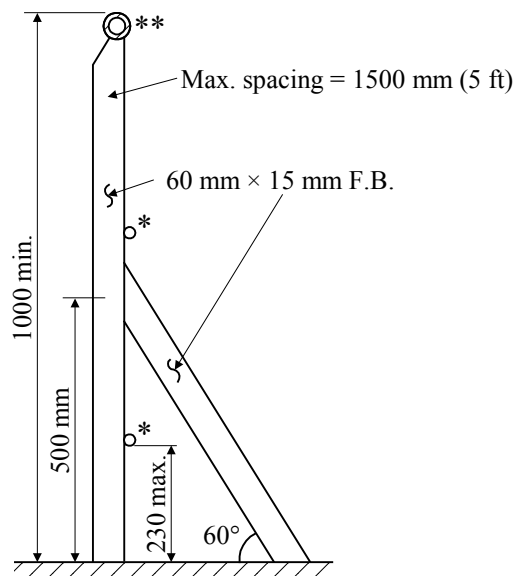
For any of the above arrangements *i*), *ii*) or *iii*), the following details are to be complied with:

- iv) Flat steel stanchion required by *i*), *ii*) or *iii*) above is to be aligned with supporting member below the deck unless the deck plating thickness exceeds 20 mm (0.79 in.)
- v) The underdeck supporting member of the stanchion is to be a minimum of 100 × 12 mm (4.0 × 0.5 in.) flat bar welded to deck by double continuous fillet weld, with minimum leg size of 7.0 mm ($5/16$ in.) or equivalent in terms of moment of inertia (see 3-2-11/Figure 2).

FIGURE 1
Guardrail Stanchion

** Top Rail = 42.4 mm outside diameter pipe with 2.6 mm minimum wall thickness (or pipes having an equivalent section modulus)

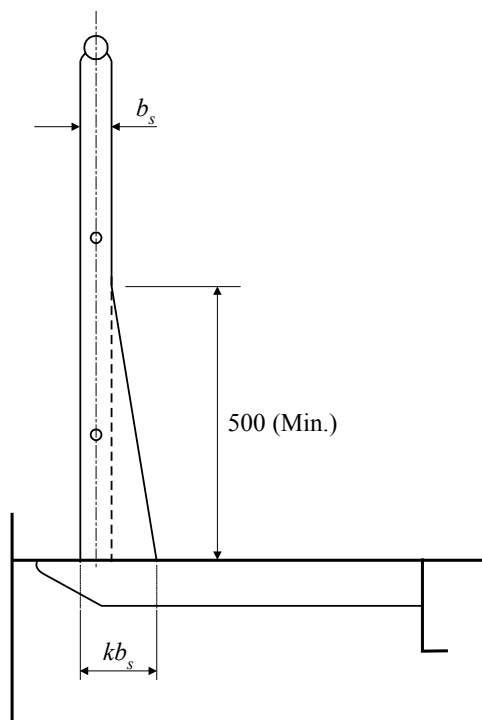
* = 20 mm solid round bar or 26.9 mm outside diameter pipe with 2.3 mm minimum wall thickness (or pipes having an equivalent section modulus)



Standard stanchion, rail, and stay sizes.

(Stay to be provided at every third stanchion)

**FIGURE 2
Guardrail Stanchion**



1.5.3

The clear opening below the lowest course is not to exceed 230 mm (9 in.). Where a foot-stop is installed at the deck level the clear opening below the lowest course may be measured from the top of the foot-stop. The clear distances between the lowest and the middle courses, as well as the middle and the upper courses are not to exceed 380 mm (15 in.).

The distance between the lower rail and the top of the sheerstrake is not to exceed 230 mm (9 in.).

1.5.4

For vessels with rounded gunwales, stanchions are to be placed on the flat of the deck.

1.7 Guard Rail Scantling Correction

When aluminum guard rails are used, calculate an equivalent section modulus to the standard shown in 3-2-11/Figure 1, using the below formula.

$$SM_{al} = 0.9Q_0SM_s$$

where

SM_{al} = minimum section modulus of aluminum guardrail

SM_s = offered section modulus of guardrail as shown in 3-2-11/Figure 1

Q = material factor, as determined from 3-2-11/1.7.1

Q_0 = material factor, as determined from 3-2-11/1.7.1

1.7.1 Material Factors

The material factor, Q , is obtained from the following equation:

$$Q = 0.9 + (120/Y_{al}) \quad \text{SI Units}$$

$$Q = 0.9 + (12/Y_{al}) \quad \text{MKS Units}$$

$$Q = 0.9 + (17000/Y_{al}) \quad \text{U.S. Units}$$

but is not to be taken as less than Q_0 below.

The material factor, Q_0 , is obtained from the following equation:

$$Q_0 = 635/(\sigma_y + \sigma_u) \quad \text{SI Units}$$

$$Q_0 = 65/(\sigma_y + \sigma_u) \quad \text{MKS Units}$$

$$Q_0 = 92000/(\sigma_y + \sigma_u) \quad \text{U.S. Units}$$

Y_{al} = minimum yield strength of the welded aluminum alloy under consideration at 2% offset in a 254 mm (10 in.) gauge length, in N/mm² (kgf/mm², psi), in accordance with the requirements of the table below

σ_u = minimum ultimate strength of the welded aluminum alloy under consideration, in N/mm² (kgf/mm², psi), in accordance with the table below

σ_y = minimum yield strength of the welded aluminum alloy under consideration, in N/mm² (kgf/mm², psi), in accordance with the table below

1.9 Life Lines

Life lines, where fitted, are to be a minimum of 9.5 mm (0.375 in.) in diameter, 7 × 19 construction, and made of stainless steel wire rope. They are to have a stainless steel turnbuckle at one end and a stainless steel screw pin shackle at the other.

3 Freeing Ports

3.1 Basic Area for Craft More Than 24 meters (79 feet) in Length

Where bulwarks on freeboard decks form wells, ample provision is to be made for rapidly freeing the decks of water and for draining them. The minimum freeing-port area on each side of the craft for each well 20 m (66 ft.) or less in length is to be obtained from the following equation:

$$A = 0.7 + 0.035\ell \text{ m}^2 \quad A = 7.6 + 0.115\ell \text{ ft}^2$$

Where the bulwark length exceeds 20 m (66 ft):

$$A = 0.07\ell \text{ m}^2 \quad A = 0.23\ell \text{ ft}^2$$

where

A = freeing-port, area in m² (ft²)
 ℓ = bulwark length, in m (ft), but need not exceed 0.7L.

The minimum area for each well on superstructure decks is to be one half of the area obtained from the above equations.

If a bulwark is more than 1.2 m (3.9 ft) in height, the freeing-port area is to be increased by 0.004 m² per meter (0.04 ft² per foot) of length of well for each 0.1 m (1 ft) difference in height. If a bulwark is less than 0.9 m (3 ft) in height, the freeing-port area may be decreased by the same ratio. Where sheer is less than standard, the percentage is to be obtained by interpolation.

3.3 Basic Area for Craft Less Than 24 meters (79 feet) in Length

Freeing ports may comply with the requirements of a recognized standard acceptable to ABS in lieu of the requirements stated in 3-2-11/3.1. Examples of acceptable standards are given below:

- ABYC, Section H-4 Cockpits and Scuppers

3.5 Trunks, Deckhouses and Hatchway Coamings

Where a craft is fitted with a trunk on the freeboard deck, and open rails are not fitted in way of the trunk for at least one-half its length, or where continuous or substantially continuous hatchway side coamings are fitted or long deckhouse exist between detached superstructures, the minimum area of freeing-port openings is to be obtained from the following table:

<i>Breadth of Trunk, Deckhouse or Hatchway in Relation to Breadth of Craft</i>	<i>Area of Freeing Ports in Relation to Total Area of Bulwarks</i>
40% or less	20%
75% or more	10%

The area of freeing ports at intermediate breadths is to be obtained by linear interpolation.

3.7 Superstructure Decks

Where bulwarks on superstructure decks form wells, the bulwarks are to comply with 3-2-11/3.1 except that the minimum freeing-port area on each side of the craft for each well is to be one-half of the area obtained in 3-2-11/3.1 and 3-2-11/3.3.

3.9 Open Superstructures

In craft having superstructures that are open at either end or both ends, adequate provisions for freeing the spaces within such superstructures are to be provided; the arrangements will be subject to special approval.

3.11 Details of Freeing Ports

The lower edges of the freeing ports are to be as near the deck as practicable. Two-thirds of the required freeing-port area is to be provided in the half of the well nearest the lowest point of the sheer curve. Freeing-port openings are to be protected by rails or bars in such a manner that the maximum clear vertical or horizontal space is 230 mm (9 in.). Where shutters are fitted, ample clearance is to be provided to prevent them from jamming. Hinges are to have pins and bearings of corrosion resistant material and in general, the hinges are to be located at the top of the shutter. If the shutters are equipped with securing appliances, the appliances are to be of approved construction.

5 Portlights

5.1 Location

No portlight is to be fitted in a position with its sill below a line drawn parallel to the freeboard deck at side and having its lowest point less than $0.025B$ above the maximum load waterline or 500 mm (19.5 in.), whichever is greater. In addition, portlights are not to be fitted in spaces which are used for the carriage of cargo.

5.3 Construction

Portlights fitted below the main weather deck or in superstructure and house side plating are to be of substantial construction and provided with steel, aluminum or other approved material inside deadlights, permanently attached and arranged to be capable of being closed and secured watertight. Except in way of the machinery space, portlights may be of the hinged opening type, with hinge pins of noncorrosive material. Where vessels are subject to damaged stability requirements of 3-3-1/3.3, portlights found to be situated below a final damage equilibrium waterline are to be of the non opening type. Portlight frames are to be of steel or other approved material and are to be attached to the hull by through bolts or equivalent. Lower edges of portlights are not to be below a line parallel to the main weather deck at side having its lowest point at a distance above the design waterline either 2.5% of the craft breadth or 500 mm (19.5 in.) whichever is greater.

For craft limited in service range and weather conditions and not receiving a Load Line Certificate, consideration will be given to the omission of deadlights depending on the type and thickness of the portlight.

The thickness of portlights of tempered or toughened monolithic safety glass is to be not less than given in 3-2-11/Table 1. Consideration will also be given to laminated glass, acrylic and polycarbonate glazing materials based upon equivalent flexural strength and stiffness. See 3-2-11/Table 3 for glazing mechanical properties.

In addition to the above, where the craft is assigned a load line in accordance with the International Convention on Load Lines, 1966 (as amended), portlights and deadlights are to meet the requirements of Regulation 23 of the Convention.

5.5 Testing

All portlights are to be hose tested in position under a water pressure of at least 2 bar (2 kgf/cm², 30 lb/in²)

The flexural strength of the glass is to be verified by compliance with the proof load in ISO 614.

TABLE 1
Thickness of Tempered or Toughened Monolithic Glass Portlights

a Rounded Portlights

<i>Location</i>	<i>General</i>	<i>Limited Service Craft</i>
Side Shell below main weather deck	0.050 <i>d</i>	0.040 <i>d</i>
Superstructure or deckhouse on main weather deck	0.033 <i>d</i>	0.033 <i>d</i>
Deckhouse above main weather deck	0.025 <i>d</i>	0.025 <i>d</i>

Notes:

- 1 *d* is taken as the diameter between inner edges of the portlight frame in mm (in).
- 2 For calculations of required thickness on limited service craft, *d* is not to be taken less than 250 mm (10 in.)

b Rectangular Portlights

<i>Location</i>	<i>General</i>	<i>Limited Service Craft</i>
Side shell below main weather deck	0.091 <i>s</i> √ <i>k</i>	0.073 <i>s</i> √ <i>k</i>
Superstructures or deckhouses on main weather deck	0.060 <i>s</i> √ <i>k</i>	0.060 <i>s</i> √ <i>k</i>
Deckhouses above main weather deck	0.045 <i>s</i> √ <i>k</i>	0.045 <i>s</i> √ <i>k</i>

Note: *k* is to be taken from 3-2-11/Table 2; *s* is the short panel dimension and *ℓ* is the long window dimension

7 Windows

7.1 Construction

Windows are defined as being rectangular openings generally, or oval, openings with an area exceeding 0.16 m² (1.72 ft²).

Windows to spaces within enclosed superstructure and deckhouses are to be fitted with strong steel, aluminum or other approved material, storm shutters. Windows are not to be fitted below the freeboard deck. Windows are not to be fitted in the first tier end bulkheads or sides of enclosed superstructures. Windows are not to be fitted in first tier deckhouses considered buoyant in the stability calculations or protecting openings leading below. Window frames are to be of steel or other approved material and are to be attached by through bolts or equivalent.

Windows on the second tier above the freeboard deck may not require deadlights depending upon the arrangement of the craft. Window frames are to be metal or other approval material, and effectively secured to the adjacent structure. Windows are to have a minimum of a 1/4" radius at all corners. The glazing is to be set into the frames in a suitable, approved packing or compound. Special consideration to be given to angled house fronts.

For externally fitted storm covers an arrangement for safe and easy access is to be provided.

For craft limited in service range and weather conditions and not receiving a Load Line Certificate, consideration will be given to the omission of deadlights depending on the location, type and thickness of the windows.

In addition to the above, where the craft is assigned a load line in accordance with the International Convention on Load Lines, 1966 (as amended), windows and storm shutters are to meet the requirements of Regulation 23 of the Convention.

The thickness of the window is not to be less than that obtained from 3-2-11/7.1.1, 3-2-11/7.1.2 or 3-2-11/7.1.3 below, whichever is greater.

7.1.1

$$t = s \left(\sqrt{\frac{pk}{1000\sigma_a}} \right) \text{ mm} \qquad t = s \left(\sqrt{\frac{pk}{\sigma_a}} \right) \text{ in.}$$

7.1.2

$$t = s \left(\sqrt[3]{\frac{pk_1}{20E}} \right) \text{ mm} \qquad t = s \left(\sqrt[3]{\frac{pk_1}{0.02E}} \right) \text{ in.}$$

7.1.3 Minimum Tempered Monolithic Glass Thicknesses:

$t = 9.5 \text{ mm (0.37 in.)}$ for front windows

$t = 6.5 \text{ mm (0.25 in.)}$ for side and end windows.

where

- t = required window thickness, in mm (in.)
- s = lesser dimension of window, in mm (in.)
- p = pressure head for window location as determined by 3-2-2/7
- k = factor given in 3-2-11/Table 2
- k_1 = factor given in 3-2-11/Table 2
- σ_a = $0.30\sigma_f$
- σ_f = material flexural strength; see 3-2-11/Table 3
- E = material flexural modulus; see 3-2-11/Table 3

TABLE 2

ℓ/s	k	k_1
>5	0.750	0.142
5	0.748	0.142
4	0.741	0.140
3	0.713	0.134
2	0.610	0.111
1.8	0.569	0.102
1.6	0.517	0.091
1.4	0.435	0.077
1.2	0.376	0.062
1	0.287	0.044

Note: s = lesser dimension of window panel, in mm (in.)

ℓ = greater dimension of window panel, in mm (in.)

Intermediate values may be determined by linear interpolation.

TABLE 3

<i>Glazing</i>	<i>Flexural Strength</i>	<i>Flexural Modulus</i>
Tempered Monolithic	119 MPa (17,200 psi)	73,000 MPa (10,600,000 psi)
Laminated Glass	69 Mpa (10,000 psi)	2,620 MPa (380,000 psi)
Polycarbonate*	93 MPa (13,500 psi)	2,345 MPa (340,000 psi)
Acrylic (PMMA)*	110 Mpa (16,000 psi)	3,000 MPa (435,000 psi)

* Special considerations will be made with regards to design, manufacture and testing of glass specimens.

7.3 Testing

All windows are to be hose tested in position under a water pressure of at least 2 bar (2 kgf/cm², 30 lb/in²)
 The flexural strength of the glass is to be verified by compliance with the proof load in ISO 614.

9 Ventilators, Tank Vents and Overflows

9.1 General

Ventilators are to comply with the requirements of 3-2-11/9.3. Tank vents and overflows are to comply with the requirements in 3-2-11/9.5. In addition, for those located on the fore deck of craft with length *L* (as defined in 3-1-1/3) not less than 80 meters (263 feet), the requirements given in 3-2-11/9.7 are to be complied with.

9.3 Ventilators

9.3.1 Coaming Construction

Ventilators on exposed freeboard decks, superstructure decks, or deckhouses are to have coamings of steel or equivalent material. Coaming plate thicknesses for steel are to be obtained from the following equation:

$$t = 0.01d + 5.5 \text{ mm} \qquad t = 0.01d + 0.22 \text{ in.}$$

where

- t* = thickness of coaming, in mm (in.)
- d* = diameter of ventilator, in mm (in.), but not less than 200 mm (7.5 in.)

The maximum steel coaming plate thickness required is 10 mm (0.40 in.). The coamings are to be effectively secured to the deck. Coamings which are more than 900 mm (35.5 in.) high and which are not supported by adjacent structures are to have additional strength and attachment. Ventilators passing through superstructures other than enclosed superstructures are to have substantially constructed coamings of steel or equivalent material at the freeboard deck. Coaming plate thickness of material other than steel will be specially considered.

9.3.2 Coaming Height

Ventilators in Position 1 are to have coamings at least 900 mm (35.5 in.) high. Ventilators in Position 2 are to have coamings at least 760 mm (30 in.) high. For definitions of Position 1 and Position 2, see 3-2-9/3.

9.3.3 Means for Closing Ventilators

Except as provided below, ventilator openings are to be provided with efficient, permanently attached closing appliances. In craft measuring 24 m (79 ft) or more in length (as defined in the International Convention on Load Lines, 1966), ventilators in Position 1, the coamings of which extend to more than 4.5 m (14.8 ft) above the deck and in Position 2, the coamings of which extend to more than 2.3 m (7.5 ft) above the deck, need not be fitted with closing arrangements.

These coaming height requirements may be modified in craft measuring less than 24 m (79 ft) in length.

9.5 Tank Vents and Overflows

Tank vents and overflows are to be in accordance with the requirements of 4-4-3/9.1 and 4-4-3/11 of this Guide and, where applicable, the requirements given below in 3-2-11/9.7.

9.7 Ventilators, Tank Vents and Overflows on the Fore Deck

9.7.1 Application

The requirements of this paragraph applies to all ventilators, tank vents and overflows located on the exposed fore deck within the forward $0.25L$ on craft with length L (as defined in 3-1-1/3) not less than 80 meters (263 feet) and where the height of the exposed deck in way of the item is less than $0.1L$ or 22 meters (72 ft) above the summer load waterline, whichever is the lesser.

9.7.2 Applied Loading to the Air Pipes and Ventilators

9.7.2(a) *Pressure.* The pressures p , in kN/m^2 (tf/m^2 , Ltf/ft^2), acting on air pipes, ventilator pipes and their closing devices, may be calculated from:

$$p = f \rho V^2 C_d C_s C_p \quad \text{kN/m}^2 \text{ (tf/m}^2, \text{ Ltf/ft}^2)$$

where:

- f = 0.5 (0.05, 0.0156)
- ρ = density of sea water, 1.025 t/m^3 (1.025 t/m^3 , 0.0286 Lt/ft^3)
- V = velocity of water over the fore deck, 13.5 m/sec (44.3 ft/sec)
- C_d = shape coefficient
 - = 0.5 for pipes
 - = 1.3 for pipes or ventilator heads in general
 - = 0.8 for pipes or ventilator heads of cylindrical form with its axis in the vertical direction
- C_s = slamming coefficient, 3.2
- C_p = protection coefficient:
 - = 0.7 for pipes and ventilator heads located immediately behind a breakwater or forecastle
 - = 1.0 elsewhere including immediately behind a bulwark

9.7.2(b) *Force.* Forces acting in the horizontal direction on the pipe and its closing device may be calculated from the above pressure using the largest projected area of each component.

9.7.3 Strength Requirements for Ventilators, Tank Vents and Overflows and their Closing Devices

9.7.3(a) *Bending Moment and Stress.* Bending moments and stresses in air pipes and ventilator pipes are to be calculated at critical positions: at penetration pieces, at weld or flange connections, at toes of supporting brackets. Bending stresses in the net section are not to exceed $0.8Y$, where Y is the specified minimum yield stress or 0.2% proof stress of the steel at room temperature. Irrespective of corrosion protection, a corrosion addition to the net section of 2.0 mm (0.08 in.) is then to be applied.

9.7.3(b) Tank Vents and Overflows

- i) For standard tank vents and overflows of 760 mm (30 in.) height closed by heads of not more than the tabulated projected area, pipe thicknesses and bracket heights are specified in 3-2-14/Table 4. Where brackets are required, three or more radial brackets are to be fitted.
- ii) Brackets are to be of gross thickness of 8 mm (0.32 in.) or more, of minimum length of 100 mm (4.0 in.), and height according to 3-2-11/Table 4, but need not extend over the joint flange for the head. Bracket toes at the deck are to be suitably supported.
- iii) For other configurations, loads according to 3-2-11/9.7.2 are to be applied, and means of support determined in order to comply with the requirements above. Brackets, where fitted, are to be of suitable thickness and length according to their height.
- iv) Final (gross) pipe thickness for air pipes is not to be taken less than as indicated in 4-3-3/9.3.1
- v) The minimum internal diameter of the air pipe or overflow is not to be less than 38 mm.

9.7.3(c) Ventilators

- i) For standard ventilators of 900 mm (35.4 in.) height closed by heads of not more than the tabulated projected area, pipe thicknesses and bracket heights are specified in 3-2-11/Table 5. Brackets, where required, are to be as specified in 3-2-11/9.7.3(b)iii).
- ii) For ventilators of height greater than 900 mm (35.4 in.), brackets or alternative means of support are to be provided. Coaming is not to be taken less than as indicated in 3-2-11/9.3 nor in 3-2-11/Table 4.

9.7.3(d) Components and Connections. All component parts and connections of the tank vents and overflows or ventilators are to be capable of withstanding the loads defined in 3-2-11/9.7.2.

9.7.3(e) Rotary Heads. Rotating type mushroom ventilator heads are not to be used for application in this location.

TABLE 4
760 mm (30 in.) High Tank Vents and Overflows Thickness and Bracket Standards

Nominal Pipe Size		Minimum Fitted Gross Thickness		Maximum Projected Area of Head		Height ⁽¹⁾ of Brackets	
A	B	mm	in.	cm ²	in ²	mm	in.
65	2½	6.0	---	---	---	480	18.9
80	3	6.3	0.25	---	---	460	18.1
100	4	7.0	0.28	---	---	380	15.0
125	5	7.8	0.31	---	---	300	11.8
150	6	8.5	0.33	---	---	300	11.8
175	7	8.5	0.33	---	---	300	11.8
200	8	8.5 ⁽²⁾	0.33 ⁽²⁾	1900	295	300	11.8
250	10	8.5 ⁽²⁾	0.33 ⁽²⁾	2500	388	300 ⁽²⁾	11.8 ⁽²⁾
300	12	8.5 ⁽²⁾	0.33 ⁽²⁾	3200	496	300 ⁽²⁾	11.8 ⁽²⁾
350	14	8.5 ⁽²⁾	0.33 ⁽²⁾	3800	589	300 ⁽²⁾	11.8 ⁽²⁾
400	16	8.5 ⁽²⁾	0.33 ⁽²⁾	4500	698	300 ⁽²⁾	11.8 ⁽²⁾

Notes:

- 1 Brackets [see 3-2-11/9.7.3(b)] need not extend over the joint flange for the head.
- 2 Brackets are required where the as fitted (gross) thickness is less than 10.5 mm (0.41 in.), or where the tabulated projected head area is exceeded.

Note: For other air pipe heights, the relevant requirements of 3-2-11/9.7.3 are to be applied.

TABLE 5
900 mm (35.4 in.) High Ventilator Thickness and Bracket Standards

<i>Nominal Pipe Size</i>		<i>Minimum Fitted Gross Thickness</i>		<i>Maximum Projected Area of Head</i>		<i>Height ⁽¹⁾ of Brackets</i>	
<i>A</i>	<i>B</i>	<i>mm</i>	<i>in.</i>	<i>cm²</i>	<i>in²</i>	<i>mm</i>	<i>in.</i>
<i>mm</i>	<i>in.</i>	<i>mm</i>	<i>in.</i>	<i>cm²</i>	<i>in²</i>	<i>mm</i>	<i>in.</i>
80	3	6.3	0.25	-	-	460	18.1
100	4	7.0	0.28	-	-	380	15.0
150	6	8.5	0.33	-	-	300	11.8
200	8	8.5	0.33	550	85	-	-
250	10	8.5	0.33	880	136	-	-
300	12	8.5	0.33	1200	186	-	-
350	14	8.5	0.33	2000	310	-	-
400	16	8.5	0.33	2700	419	-	-
450	18	8.5	0.33	3300	511	-	-
500	20	8.5	0.33	4000	620	-	-

Note: For other ventilator heights, the relevant requirements of 3-2-11/9.7.3 are to be applied.

CHAPTER 2 Hull Structures and Arrangements**SECTION 12 Protective Coatings****1 General**

Unless otherwise approved, all steel work is to be suitably coated with paint or equivalent. No final painting or coating is to be performed until all surveys and testing have been completed. All areas not being coated are to be protected during painting, and upon completion of the work any paint accidentally applied to the areas are to be removed.

3 Preparation

Surfaces that are to be painted are to be completely free of rust, loose paint, dirt, scale, oil, grease, salt deposits, and moisture. Protective coatings are to be applied as soon as practical after cleaning before corrosion or soil forms on the cleaned surface.

If more than seven days elapse between epoxy coats, the surface should be cleaned prior to an application of a tack coat (1-2 wet mils) before the application of the next full coat.

5 Protection of Steel**5.1 Preparation**

All steel surfaces that will be coated are to be abrasive blast cleaned. Prior to abrasive blast cleaning, surfaces contaminated with oil or grease are to be cleaned and weld splatters, slag, and flux compounds are to be removed by grinding, sanding, or chipping. In areas where abrasive blasting is not feasible, the surfaces are to be cleaned by mechanical means to remove foreign matter.

Galvanized steels shall be roughened with a light abrasive blast or by mechanical means prior to painting.

5.3 All Spaces

Unless otherwise approved, all steel work is to be suitably coated with paint or equivalent.

5.5 Salt Water Ballast Space

Tanks or holds for salt water ballast are to have a corrosion-resistant hard type coating such as epoxy or zinc on all structural surfaces. Where a long retention of salt water is expected due to the type of craft or unit, special consideration for the use of inhibitors or sacrificial anodes may be given.

5.7 Oil Spaces

Tanks intended for oil need not be coated.

7 Protection of Aluminum

7.1 General

Aluminum alloys intended for hull construction are to be used generally only under conditions that will not induce excessive corrosion. Where exposure to environment that would induce excessive corrosion is expected, suitable coatings, tapes, sacrificial anodes, impressed-current systems or other corrosion prevention measures are to be used. When tapes are used for corrosion protection, they are to be non-wicking and non-water absorbing. Grease containing graphite is not to be used with aluminum, instead, zinc or other suitable base grease is to be used.

7.3 Preparation

All aluminum surfaces that will be coated are to be thoroughly cleaned to bare metal, free of corrosion products, dirt, and other contaminants, by light abrasive blasting. Spot cleaning after blasting can be done by power brushing or orbital sanding.

7.5 Coatings

Coatings are to be applied in accordance with the manufacturer's instructions, and are to be preceded by appropriate cleaning and possibly chemical conversion of surfaces as may be required in accordance with the manufacturer's recommendations. Coatings are to be free from voids, scratches or other imperfections that are potential sites for localized corrosion.

The composition of coatings is to be compatible with aluminum. Coatings containing copper, lead, mercury or other metals that can induce galvanic or other forms of corrosion are not to be used. Zinc chromate coatings may be used. Insulating coatings intended to prevent galvanic corrosion are not to contain graphite or other conducting materials.

7.7 Faying Surfaces – Aluminum to Aluminum

Aluminum faying surfaces that will be exposed to weather, seawater, or other corrosive environment are to be suitable coated to minimize crevice corrosion in way of the faying surfaces.

7.9 Faying Surface between Aluminum and Other Metals

7.9.1 Hull

Suitable means are to be taken to avoid direct contact of faying surfaces of aluminum to other metals. When such faying surfaces occur in hull construction, suitable non-wicking and non-water absorbing insulation tapes or coatings are to be used. Faying surfaces between mechanically fastened metal components, except machinery foundations, are to be protected by the use of bedding compounds or adhesives. Other types of joints between aluminum and other metals may be approved in certain applications.

7.9.2 Piping

Suitable means, such as special pipe hangers, are to be used to avoid conductive connections between aluminum hulls and non-aluminum metal piping systems. Where watertightness is required, such as when piping passes through bulkheads, decks, tanktops, and shell, special fittings will be required to maintain isolation between dissimilar metals.

7.9.3 Bearing Areas

Bearing areas such as engine beds, pump foundations, propeller shafts, rudder and other appendages of metals other than aluminum are to be suitably isolated by such means as non-metallic bearing casing, non-conductive packing (not containing graphite or other conductors) or suitable tapes and coatings. Alternative methods for minimizing corrosion at these locations will be specially considered. Wicking-type tapes or water-absorbing packing materials such as canvas should not be used. The metals used for such applications are to be selected to minimize galvanic effects; stainless steels are to be considered. The use of copper-base alloys such as brass or bronze is generally not recommended where galvanic corrosion is of concern, and these materials may only be used when specially approved. In those cases where the use of dissimilar metals cannot be avoided, or where galvanic corrosion is of concern, such as in wet tanks, a suitable sacrificial anode or impressed current system should be installed.

7.11 Faying Surface between Aluminum and Non-metals

Aluminum in contact with wood or insulating-type material is to be protected from the corrosive effects of the impurities in these materials by a suitable coating or covering. Concrete used with aluminum is to be free of additives for cold weather pouring. Preformed glass insulation is recommended for piping insulation. Any adhesives which may be used to connect insulation to aluminum are to be free of agents that would be corrosive to aluminum. Foaming agents harmful to aluminum, such as Freon, are not to be used for insulating foams. Areas where dirt or soot is likely to collect and remain for prolonged periods are to be protected from pitting corrosion by the use of coatings or other suitable means.

7.13 Corrosion of Wet Spaces

Suitable means are to be used to avoid arrangements that could induce crevice corrosion in wet spaces. In bilge spaces, chain lockers, and similar locations where exfoliation corrosion may be of concern, appropriate materials suitably heat treated for resistance to this form of corrosion are to be employed.

7.15 Service at Elevated Temperatures

For service temperatures of 66°C (150°F) or above, only aluminum alloys and filler metals specially designated for service at these temperatures are to be used.

7.17 Cathodic Protection for Corrosion Prevention

For application where corrosion is of concern, consideration is to be given to the use of sacrificial anode or impressed current systems of corrosion control. Details of sacrificial anodes and arrangements are to be submitted for review. Anodes are to be in accordance with ASTM or other recognized standard. When impressed current systems are used, adequate precautions are to be taken that the negative voltage is not excessive.

7.19 Stray Current Protection

Precautions are to be taken when in dock to prevent stray currents from welding power or other sources from adversely affecting the aluminum. Whenever possible, the cathodic protection system of the craft should be in place and operating when the craft is in the water. AC power sources are to be insulated from the hull. For battery and other DC power sources, grounding is to be avoided if possible. Where safety considerations require grounding to the hull, the negative pole is to be connected to the hull.

7.21 Bi-material Joints

Such joints, when used, may be required to be appropriately painted, coated, wrapped or protected by other methods to prevent galvanic corrosion. Where aluminum is to be joined to other materials, each faying surface is to be suitably coated to minimize corrosion. In addition, when one or both sides of an aluminum or steel connection to dissimilar metal joints are exposed to weather, sea water, or wet spaces, a minimum of 0.5 mm (0.02 in.) of suitable insulation is to be installed between faying surfaces and extended beyond the edge of the joint. Non-welded oil or water stops are to be of plastic insulation tape or equivalent which would provide a suitably corrosion resistant system. Insulating materials are to be non-porous and have mechanical properties suitable for the application.

9 Protection of Fiber Reinforced Plastic

9.1 General

Cured gel-coat resins and lay-up resin are to be highly resistant to water and other liquid absorption; appropriate materials, lay-up, and lay-up procedures are to be used and manufacturer's recommendations followed to attain this. Care is to be taken in the use of laminates containing carbon fibers so that they are not close to or do not induce galvanic corrosion with metal fittings.

9.3 Preparation

Composite surfaces that are not coated in the mold are to be sanded lightly to remove any foreign matter. Care is to be taken not to expose any of the structural glass. Surfaces are to be cleaned with water and solvent to ensure the removal of residual mold release compound, oil, or grease.

9.5 Tanks

In water, fuel oil, or other approved tanks, the resins used are to be compatible with the contents of the tanks; the contents of the tanks are not to affect the cured properties of the tank laminate. The cured laminate is to be highly resistant to absorption of the liquid, and is not to have harmful, deleterious, or undesirable effects on the contents of the tank. The tank is generally to be gel-coated on the inside. See also 3-2-5/5.1.

9.7 Cathodic Protection

Cathodic protection is to be provided where shaft struts, propeller shafts, propellers, rudders, fittings, etc. are constructed of manganese bronze, brass, stainless steel or mild steel. Details of the sacrificial anodes and arrangements are to be submitted for review. Anodes are to be in accordance with ASTM or other recognized standard.

PART

3

CHAPTER 2 Hull Structures and Arrangements

SECTION 13 Welding, Forming and Weld Design

1 Fillet Welds

1.1 General

1.1.1 Plans and Specifications

The actual sizes of fillet welds are to be indicated on detail drawings or on a separate welding schedule and submitted for approval in each individual case.

1.1.2 Workmanship

Fillet welds may be made by an approved manual, semi automatic or automatic process. Completed welds are to be to the satisfaction of the attending Surveyor. The gaps between the faying surfaces of members being joined should be kept to a minimum. Where the opening between members being joined exceeds 1.0 mm (0.04 in.) and is not greater than 5 mm (3/16 in.), the weld leg size is to be increased by the amount of the opening in excess of 2.0 mm (1/16 in.). Spacing between plates forming tee joints is not to exceed 5 mm (0.1875 in.). Where the opening between members is greater than 5 mm (3/16 in.), corrective procedures are to be specially approved by the Surveyor.

1.1.3 Special Precautions

Special precaution such as the use of preheat or low-hydrogen electrodes or low-hydrogen welding processes may be required where small fillets are used to attach heavy plates or sections. When heavy sections are attached to relatively light plating, the weld size may be required to be modified. When terminating an aluminum weld, either continuous or intermittent, crater filling by back stepping is recommended to provide a sound ending for each fillet.

1.3 Tee Connections

In general, the required size and spacing of the fillets is to be as given in 3-2-13/1.5.

1.3.1 Size of Fillet Welds

Frames, beams, bulkheads stiffeners, floors and intercostals, etc. are to have at least the disposition and sizes of intermittent or continuous fillet welds, as required by 3-2-13/Table 1. Where it is desirable to substitute continuous welding for intermittent welding, as given in 3-2-13/Table 1, a reduction from the required size of fillet may be allowed if equivalent strength is provided.

1.3.2 Intermittent Welding at Intersection

Where beams, stiffeners, frames, etc., are intermittently welded and pass through slotted girders, shelves or stringers, there is to be a pair of matched intermittent welds on each side of each such intersection and the beams, stiffeners and frames are to be efficiently attached to the girders, shelves and stringers.

1.3.3 Welding of Longitudinal to Plating

Welding of longitudinals to plating is to have double continuous welds at the ends and in way of transverses equal in length to the depth of the longitudinal. For deck longitudinals only, a matched pair of welds is required at the transverses.

1.3.4 Stiffeners and Webs to Hatch Covers

Unbracketed stiffeners and webs of hatch covers are to be welded continuously to the plating and to the face plate for a length at ends equal to the end depth of the member.

1.5 Fillet Sizes and Spacing

Tee connections are to be formed by continuous or intermittent fillet welds on each side, the leg size, w , of the fillet welds is to be obtained from the following equations:

$$w = t_p \times C \times \frac{s}{\ell} + 1.5 \text{ mm} \qquad w = t_p \times C \times \frac{s}{\ell} + 0.06 \text{ in.}$$

where

- w = size of the weld leg, in mm (in.)
- ℓ = actual length of the weld fillet, clear of crater, in mm (in.). See 3-2-13/Figure 1
- s = distance between centers of weld fillets, in mm (in.). See 3-2-13/Figure 1
- t_p = thickness of the thinner of the two members being joined, in mm (in.)
- C = weld factor given in 3-2-13/Table 1

w is not to be taken less than $0.3t_p$ or 3.5 mm (0.14 in.), whichever is greater.

The throat thickness of the fillet is to be not less than $0.7w$.

In calculating weld factors, the leg length of matched fillet weld is to be taken as the designated leg length or $0.7t_p + 2.0$ mm ($0.7t_p + 0.08$ in.), whichever is less.

Where it is intended to use continuous fillet welding, the leg size of fillet welds is to be obtained from the above equations taking s/ℓ equal to 1.

For intermittent welding with plate thickness less than 7 mm (0.28 in.) welds are to be staggered.

1.7 Thin Plating

For plating of 6.5 mm (0.25 in.) or less, the requirements of 3-2-13/1.5 may be modified as follows:

$$W = t_{p\ell} \times C \times \frac{s}{\ell} + 2.0[1.25 - (\ell/s)] \text{ mm}$$

$$W = t_{p\ell} \times C \times \frac{s}{\ell} + 0.08[1.25 - (\ell/s)] \text{ in.}$$

$$W_{\min} = 3.5 \text{ mm (0.14 in.)}$$

For plates less than 4.5 mm (0.1875 in.), welds less than required above will be specially considered.

1.9 Length and Arrangement of Fillet

Where an intermittent weld is permitted by 3-2-13/Table 1, the length of each fillet weld is to be not less than 75 mm (3 in.) for $t_{p\ell}$ of 7 mm (0.28 in.) or more, nor less than 65 mm (2.5 in.) for lesser $t_{p\ell}$.

The unwelded length is to be not more than $32 t_{p\ell}$.

1.11 Fillet Weld Arrangements

1.11.1 Intersections

Where beams, stiffeners, frames, etc., are intermittently welded and pass through slotted girders, shelves or stringers, there is to be a pair of matched intermittent welds on each side of each such intersection and the beams, stiffeners and frames are to be efficiently attached to the girders, shelves and stringers. The length of the matched intermittent fillet welds is to be 0.125 times the span or 100 mm (4 in.), whichever is greater.

1.11.2 Unbracketed End Attachments

Unbracketed beams, frames, etc., and stiffeners of watertight and tank bulkheads and superstructure and house fronts are to have double continuous welds for length at each end equal to the depth of the member but not less than 0.125 times the span or 100 mm (4 in.), whichever is greater.

1.11.3 Bracketed End Attachments

Frames, beams, stiffeners etc., are to be lapped onto the bracket a length not less than 1.5 times the depth of the member, and are to have continuous fillet welds all around. Lapped end connections of longitudinal strength members are also to have a throat size, t , such that the total effective area of the lap welding is not less than the area of the member being attached.

1.11.4 Lapped Joints

Lapped joints are typically not to be used in structural applications or on plates greater than 6 mm (0.25 in.) thick, unless specially approved.

Lapped joints are generally to have a width of overlap not less than twice the thickness of thinner plate plus 25 mm (1 in.) with welds on both edges of the sizes required by 3-2-13/1.5.

1.11.5 Plug Welds or Slot Welds

Plug welds or slot welds are to be specially approved for particular applications. When approved, an appropriate demonstration that adequate weld penetration and soundness is achieved is to be made to the Surveyor's satisfaction. When used in the attachment of doublers and similar applications, plug or slot welds may be spaced at 16 times the doubler thickness, but not more than 300 mm (12 in.) between centers in both directions. In general, elongated slot welds are recommended. For closing plates on rudders, slots are to be 75 mm (3 in.) in length spaced at 150 mm (6 in.) between centers. The periphery of the plugs or slots are to be fillet welded, of fillet size, w , generally not less than 0.70 times the plate thickness. Plugs and slots are not to be filled with welded deposit.

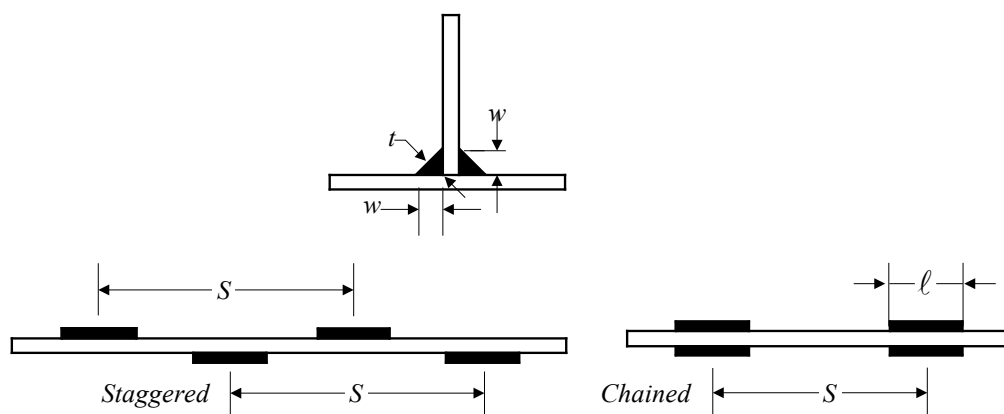
3 Bi-material Joints

Techniques required for joining two different materials will be subject to special consideration. The use of explosion bonding may be considered depending on the application and the mechanical and corrosive properties of the joint.

5 Alternatives

The foregoing are considered minimum requirements for welding in hull construction, but alternative methods, arrangements and details will be considered for approval. Fillet weld sizes may be determined from structural analyses based on sound engineering principles, provided they meet the overall strength standards of the Rules.

FIGURE 1



w = leg size in mm (in.)

t = throat size in mm (in.)

TABLE 1
Weld Factor C

	<i>Aluminum</i>	<i>Steel</i>
<i>Floors, Bottom Transverses, and Bottom Longitudinal Girders to Shell</i>		
At Bottom forward 3L/8,	0.25 DC	0.25 DC
At Bottom forward L/4, $V \leq 25$ knots	0.18 DC	0.16 DC
In way of propellers and shaft struts	0.25 DC	0.25 DC
In machinery space	0.20	0.20
Elsewhere	0.16	0.14
<i>Floors, Bottom Transverses and Bottom Longitudinal Girders to Inner Bottom or Face Bar</i>		
In machinery space	0.25 DC	0.25 DC
To Inner bottom elsewhere	0.14	0.12
To face plate elsewhere	0.14	0.12
<i>Floors and Bottom Transverse to Bottom Girders</i>	0.30 DC	0.30 DC
<i>Bottom Girders to Bulkheads and Deep Transverses or Floors</i>	0.30 DC	0.30 DC
<i>End Attachments</i>	0.50 DC	0.50 DC
<i>Longitudinals to Shell (including frames on transversely framed craft)</i>		
Bottom and side forward 3L/8, $V > 25$ knots	0.25 DC	0.25 DC
Bottom and side forward L/4, $V \leq 25$ knots	0.18 DC	0.16 DC
In way of propellers and shaft struts	0.25 DC	0.25 DC
Elsewhere	0.14	0.12
End Attachments	0.50 DC	0.50 DC
<i>Side, Deck, and Bulkhead Girders, Transverses and Stringers</i>		
To Shell 3L/8, $V > 25$ knots	0.18 DC	0.16 DC
To Shell Forward L/4, ≤ 25 knots	0.16 DC	0.14 DC
Insert To Shell Elsewhere	0.16	0.14
To Deck and Bulkheads Clear of Tanks	0.16	0.14
To Deck and Bulkheads In way of Tanks	0.18	0.16
To Face Bar	0.14	0.12
End Attachments	0.50 DC	0.50 DC
<i>Beams, Longitudinals, and Stiffeners</i>		
To Deck	0.14	0.12
To Tank Boundaries and House Fronts	0.14	0.12
To Watertight Bulkheads, House Side and Ends	0.14	0.12
End Attachments	0.50 DC	0.50 DC
<i>Engine Foundations to Plating and Face Bar</i>	0.50 DC	0.50 DC
<i>Bulkheads and Tank Boundaries</i>		
Non-tight, Internal	0.16	0.14
Watertight, weathertight, or exposed	0.38 DC	0.38 DC
Tank	0.40 DC	0.40 DC
<i>Deck Peripheries</i>		
Non-tight, Internal	0.25	0.25
Weathertight	0.38 DC	0.38 DC
Strength Deck	0.38 DC	0.38 DC
<i>Rudders</i>		
Diaphragms to Side Plating	0.30	0.30
Vertical Diaphragms to Horizontal Diaphragms, clear of Mainpiece	0.50 DC	0.50 DC
Horizontal Diaphragm to Vertical	0.50 DC	0.50 DC
Mainpiece Diaphragm	0.50 DC	0.50 DC
<i>Shaft Brackets to boss and doubler</i>	Full Penetration	Full Penetration

Notes:

DC = double continuous

CHAPTER **2** **Hull Structures and Arrangements**APPENDIX **1** **Guidelines for Calculating Bending Moment and Shear Force in Rudders and Rudder Stocks****1** **Application**

Bending moments, shear forces and reaction forces of rudders, stocks and bearings may be calculated according to this Appendix for the types of rudders indicated. Moments and forces on rudders of different types or shapes than those shown are to be calculated using alternative methods and will be specially considered.

3 **Spade Rudders****3.1** **Rudder****3.1.1** **Shear Force**

Lateral shear force, $V(z)$, at a horizontal section of the rudder z meters (feet) above the bottom of ℓ_R is given by the following equation:

$$V(z) = \frac{zC_R}{A} \left[c_\ell + \frac{z}{2\ell_R} (c_u - c_\ell) \right] \text{ kN (tf, Ltf)}$$

where

z = distance from the bottom of ℓ_R to the horizontal section under consideration, in m (ft). See 3-2-A1/Figure 1

C_R = rudder force, as defined in 3-2-8/3.1, in kN (tf, Ltf)

A = rudder blade area, in m² (ft²)

c_ℓ , c_u and ℓ_R are dimensions as indicated in 3-2-A1/Figure 1, in m (ft).

3.1.2 **Bending Moment**

Bending moment, $M(z)$, at a horizontal section z meters (feet) above the baseline of the rudder is given by the following equation:

$$M(z) = \frac{z^2 C_R}{2A} \left[c_\ell + \frac{z}{3\ell_R} (c_u - c_\ell) \right] \text{ kN-m, (tf-m, Ltf-ft)}$$

where z , C_R , A , c_ℓ , c_u and ℓ_R are as defined in 3-2-A1/3.1.1.

3.3 Lower Stock

3.3.1 Shear Force

Lateral shear force at any section of the lower stock between the top of the rudder and the neck bearing, V_ℓ , is given by the following equation:

$$V_\ell = C_R \quad \text{kN (tf, Ltf)}$$

where C_R is rudder force, as defined in 3-2-A1/3.1.1.

3.3.2 Bending Moment at Neck Bearing

The bending moment in the rudder stock at the neck bearing, M_n , is given by the following equation:

$$M_n = C_R \left[\ell_\ell + \frac{\ell_R (2c_\ell + c_u)}{3(c_\ell + c_u)} \right] \quad \text{kN-m (tf-m, Ltf-ft)}$$

where

$$C_R = \text{rudder force as defined in 3-2-A1/3.1.1}$$

c_ℓ, c_u, ℓ_ℓ and ℓ_R are dimensions as indicated in 3-2-A1/Figure 1, in m (ft).

3.5 Moment at Top of Upper Stock Taper

The bending moment in the upper rudder stock at the top of the taper, M_t , is given by the following equation:

$$M_t = C_R \left[\ell_\ell + \frac{\ell_R (2c_\ell + c_u)}{3(c_\ell + c_u)} \right] \times \left[\frac{(\ell_u + \ell_R + \ell_\ell - z_t)}{\ell_u} \right] \quad \text{kN-m (tf-m, Ltf-ft)}$$

where

$$z_t = \text{distance from the rudder baseline to the top of the upper rudder stock taper in m (ft)}$$

$$C_R = \text{rudder force, as defined in 3-2-A1/3.1.1}$$

$c_\ell, c_u, \ell_\ell, \ell_u$ and ℓ_R are dimensions as indicated in 3-2-A1/Figure 1, in m (ft).

3.7 Bearing Reaction Forces

Reaction forces at the bearings are given by the following equations:

$$P_u = \text{reaction force at the upper bearing}$$

$$= - \frac{M_n}{\ell_u} \quad \text{kN (tf, Ltf)}$$

$$P_n = \text{reaction force at the neck bearing}$$

$$= C_R + \frac{M_n}{\ell_u} \quad \text{kN (tf, Ltf)}$$

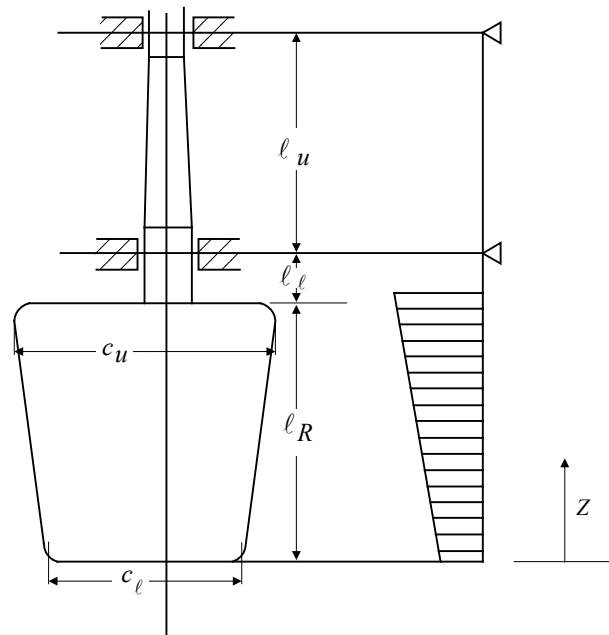
where

$$M_n = \text{bending moment at the neck bearing, as defined in 3-2-A1/3.1.2}$$

$$C_R = \text{rudder force, as defined in 3-2-A1/3.1.1.}$$

ℓ_u is as indicated in 3-2-A1/Figure 1, in m (ft).

**FIGURE 1
 Spade Rudder**



5 Rudders Supported by Shoe-piece

5.1 Shear Force, Bending Moment and Reaction Forces

Shear force, bending moment and reaction forces may be calculated according to the model given in 3-2-A1/Figure 2.

$$w_R = \text{rudder load per unit length}$$

$$= \frac{C_R}{l_R} \text{ kN/m (tf/m, Ltf/ft)}$$

where

$$C_R = \text{rudder force, as defined in 3-2-8/3}$$

$$k_s = \text{spring constant reflecting support of the shoe-piece}$$

$$= \frac{n_s I_s}{\ell_s^3} \text{ kN/m (tf/m, Ltf/ft)}$$

$$n_s = 6.18 \text{ (0.630, 279)}$$

$$I_s = \text{moment of inertia of shoe-piece about the vertical axis, in cm}^4 \text{ (in}^4\text{)}$$

$$I_u = \text{moment of inertia of the rudder stock above the neck bearing, in cm}^4 \text{ (in}^4\text{)}$$

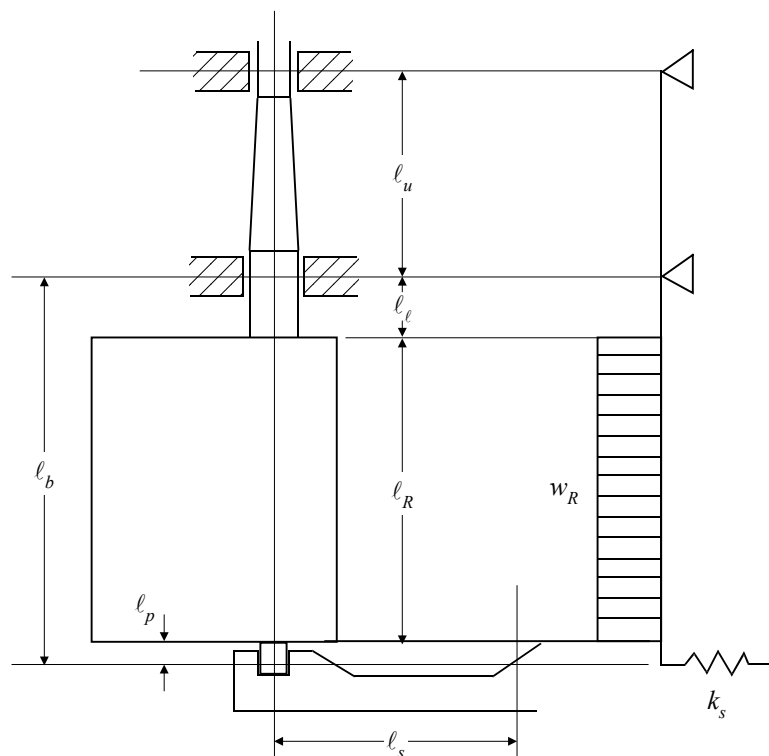
$$I_\ell = \text{moment of inertia of the rudder stock below the neck bearing, in cm}^4 \text{ (in}^4\text{)}$$

$$I_R = \text{moment of inertia of the rudder about the longitudinal axis, in cm}^4 \text{ (in}^4\text{)}$$

$$I_p = \text{moment of inertia of the pintle, in cm}^4 \text{ (in}^4\text{)}$$

ℓ_ℓ , ℓ_s , ℓ_R and ℓ_u are dimensions as indicated in 3-2-A1/Figure 2, in m (ft).

FIGURE 2
Rudder Supported by Shoe Piece



7 Rudders Supported by a Horn with One Pintle

7.1 Shear Force, Bending Moment and Reaction Forces

Shear force, bending moment and reaction forces are to be assessed by the simplified beam model shown in 3-2-A1/Figure 3.

$$w_{R1} = \text{rudder load per unit length above pintle}$$

$$= \frac{C_{R1}}{l_{R1}} \text{ kN/m (tf/m, Ltf/ft)}$$

$$w_{R2} = \text{rudder load per unit length below pintle}$$

$$= \frac{C_{R2}}{l_{R2}} \text{ kN/m (tf/m, Ltf/ft)}$$

where

$$C_{R1} = \text{rudder force, as defined in 3-2-8/3.3}$$

$$C_{R2} = \text{rudder force, as defined in 3-2-8/3.3}$$

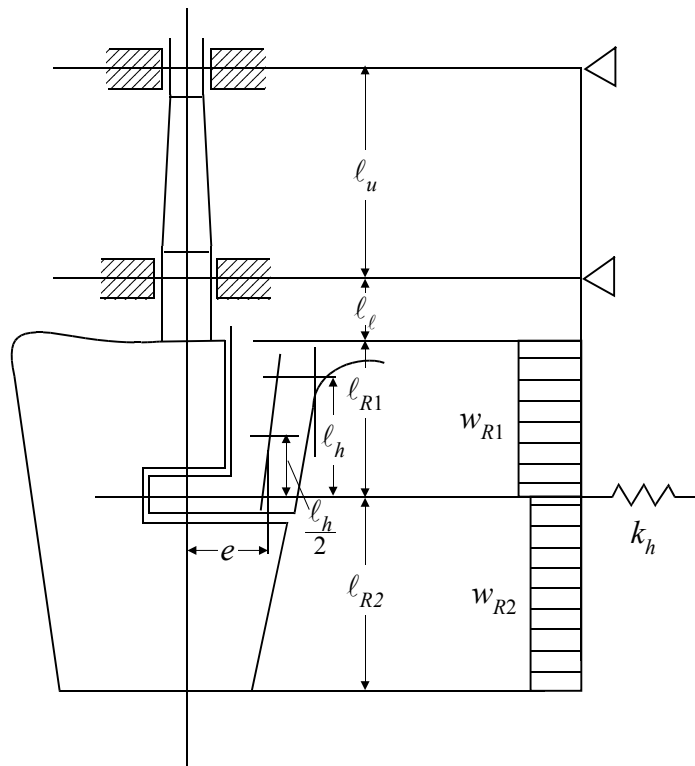
$$k_h = \text{spring constant reflecting support of the horn}$$

$$= \frac{1}{\frac{l_h^3}{n_b I_h} + \frac{\sum \left(\frac{s_i}{t_i} \right) e^2 l_h}{n_t a^2}} \text{ kN/m (tf/m, Ltf/ft)}$$

- $n_b = 4.75$ (0.485, 215)
- $n_t = 3.17$ (0.323, 143)
- $a =$ mean area enclosed by the outside lines of the rudder horn, in cm^2 (in^2)
- $s_i =$ the girth length of each segment of the horn of thickness t_i , in cm (in.)
- $t_i =$ the thickness of each segment of horn outer shell of length s_i , in cm (in.)
- $I_h =$ moment of inertia of horn section at l_h about the longitudinal axis, in cm^4 (in^4)

e , l_h , l_{R1} and l_{R2} are dimensions as indicated in 3-2-A1/Figure 3, in m (ft).

FIGURE 3
Rudder Supported by a Horn with One Pintle



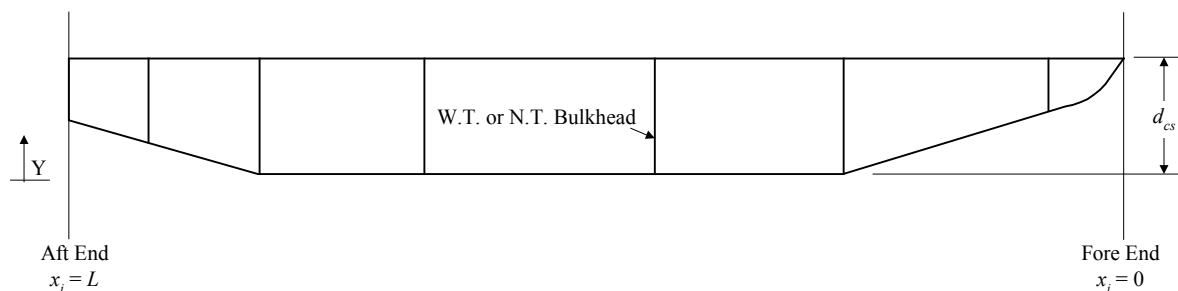
PART 3

CHAPTER 2 Hull Structures and Arrangements

APPENDIX 2 Guidance on Analysis of the Cross Deck Structure of a Multi-Hull Craft

Note: This Appendix gives guidance on the analysis of a standard cross deck structure (similar to 3-2-A2/Figure 1) of a multi-hulled craft. The analysis includes the determination of the craft's transverse bending stress, transverse shear stress, and the torsional stress acting on each element. The analysis of cross decks that are of advanced design or material will be specially considered.

FIGURE 1
Typical Geometry of Centerline Section of Cross Deck



1 Transverse Bending and Shear Stress

The transverse bending and shear stress of the cross structure are obtained by the following equations and are less than the allowable stresses defined in 3-2-1/3.5.3:

$$\sigma_t = \frac{10M_{tb}}{SM_t} \quad \text{N/mm}^2 \qquad \sigma_t = \frac{M_{tb}}{SM_t} \quad \text{psi}$$

$$\tau_a = \frac{10Q_t}{A_t} \quad \text{N/mm}^2 \qquad \tau_a = \frac{Q_t}{A_t} \quad \text{psi}$$

where

- σ_t = transverse bending stress of the cross deck structure, in N/mm² (psi)
- M_{tb} = design transverse bending moment as defined in 3-2-1/3.3, in kN-m (ft-lbs)
- SM_t = offered transverse section modulus of the cross deck, in cm²-m (in²-ft)
- τ_a = transverse shear stress of the cross deck structure, in N/mm² (psi)
- Q_t = design vertical shear force as defined in 3-2-1/3.3, in kN (lbs)
- A_t = offered shear area of the cross structure, in cm² (in²)

3 Center of Torsional Rotation

The center of torsional rotation of the cross deck structure can be determined by the following formula:

$$L_c = \frac{\sum_{i=1}^n k_i x_i}{\sum_{i=1}^n k_i} \text{ cm (in.)}$$

where

$$k_i = \text{element stiffness}$$

$$= \frac{12000E_i I_i}{L_i^3} \text{ N/m}$$

$$= \frac{12E_i I_i}{L_i^3} \text{ lbs/in}$$

x_i = longitudinal distance from forward perpendicular, in cm (in.)

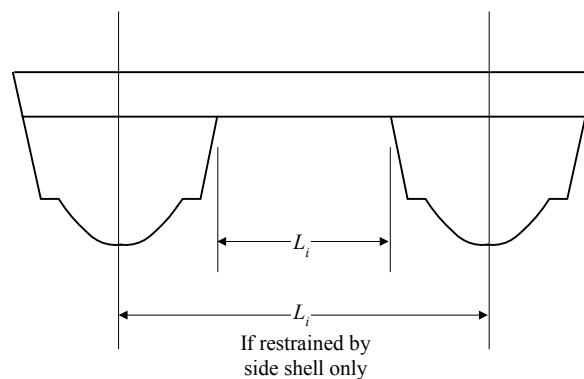
n = total number of elements in the cross deck structure

E = modulus of elasticity of the material, for each element, kN/m² (psi)

I_i = moment of inertia of the element being considered, in m⁴ (in⁴).

L_i = span of cross structure, in m (in.), see 3-2-A2/Figure 2.

FIGURE 2
Span of Cross Structure



5 Maximum Bending Stress on Each Element

The maximum bending stress on each element is to be less than the allowable torsional stress defined in 3-2-1/3.5.3

5.1 Deflection

The total amount that each element deflects can be determined by the following formula:

$$\delta_i = \frac{100000M_t x_{ci}}{\sum_{i=1}^n x_{ci}^2 k_i} \quad \text{m} \qquad \delta_i = \frac{12M_t x_{ci}}{\sum_{i=1}^n x_{ci}^2 k_i} \quad \text{in.}$$

where

$$\begin{aligned} \delta_i &= \text{deflection of each member, in m (in.)} \\ M_t &= \text{design torsional moment acting upon the transverse structure connecting the hulls, as determined 3-2-1/3.3, in kN-m (ft-lbs)} \\ x_{ci} &= x_i - L_c, \text{ in cm (in.)} \end{aligned}$$

x_i , L_c and k_i are as defined in 3-2-A2/1.

5.3 Bending Moment

The bending moment that is acting on each element is determined by the following formula:

$$BM_i = \frac{P_i L_i}{2}$$

where

$$\begin{aligned} BM_i &= \text{bending moment that is acting on the element under consideration, in N-m (in-lbs)} \\ P_i &= \delta_i k_p, \text{ force that is acting on the element, in N (lbs)} \\ L_i &= \text{as defined in 3-2-A2/1} \\ \delta_i &= \text{as defined in 3-2-A2/5.1} \\ k_i &= \text{as defined in 3-2-A2/1} \end{aligned}$$

5.5 Maximum Stress

The maximum stress that is applied on each element can be determined by the following formula:

$$\sigma_i = \frac{1000BM_i}{SM_i} \quad \text{kN/m}^2 \qquad \sigma_i = \frac{BM_i}{SM_i} \quad \text{psi}$$

where

$$\begin{aligned} \sigma_i &= \text{maximum stress that is acting upon the element, in kN/m}^2 \text{ (psi)} \\ BM_i &= \text{bending moment as defined, in 3-2-A2/5.3} \\ SM_i &= \text{section modulus of the element being considered, in cm}^3 \text{ (in}^3\text{)} \end{aligned}$$

5.7 Maximum Shear Stress on Each Element

The maximum shear stress on each element is to be less than the allowable transverse shear stress defined in 3-2-1/3.5.3.

$$\tau_i = \frac{10P_i}{A_{wi}} \text{ kN/m}^2 \qquad \tau_i = \frac{P_i}{A_{wi}} \text{ psi}$$

where

- τ_i = maximum shear stress that is acting upon the element, in kN/m² (psi)
- P_i = force acting upon the element, in N (lbs), as defined in 3-2-A2/5.3
- A_{wi} = area of the web of the element being considered, in cm² (in²)

PART
3

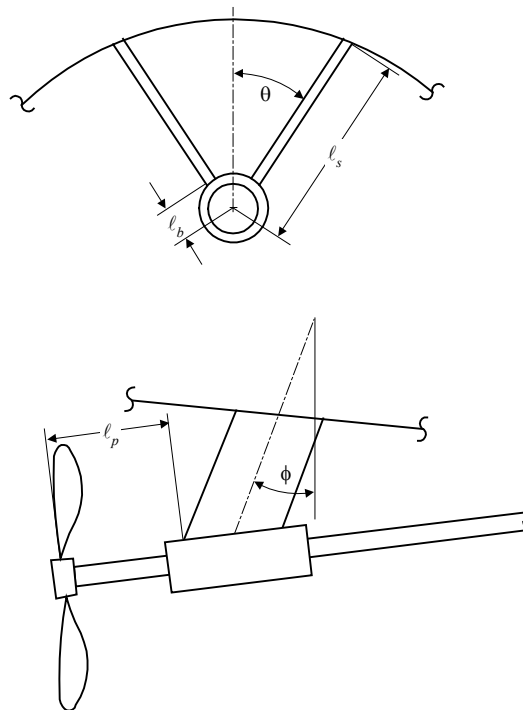
CHAPTER **2** **Hull Structures and Arrangements**

APPENDIX **3** **Alternative Method for the Determination of “V” Shaft Strut Requirements**

1 **General**

The method outlined below may be used as an alternative to the method given in 3-2-7/9. Other alternatives may be considered providing they address loadings from unbalanced centrifugal forces from the propeller, hydrodynamic forces, inertial forces from ship motions, gravity forces from shaft and propeller, and vibrations resulting from all intended conditions.

FIGURE 1
Strut Dimensions



3 **Loads and Moments Acting on Strut**

The governing loads and moments acting on the shaft strut are as follows:

$$M_1 = 0.0855d_p[W_p \ell_p (R/100)^2 + 3H_p/V] \text{ kN-m (tf-m)}$$

$$M_1 = 3.5d_p[(W_p/1000)\ell_p(R/100)^2 + 3H_p/V] \text{ in-lbf}$$

$$M_2 = 0.0003SM_s\sigma_{ys} \text{ kN-m (tf-m)}$$

$$M_2 = 0.3SM_s\sigma_{ys} \text{ in-lbf}$$

$$F_3 = SM_s\sigma_{ys}/d_s \text{ kN (tf, lbf)}$$

where

- d_p = diameter of the propeller, in mm (in.)
- W_p = weight of the propeller, in kN (lbf)
- ℓ_p = length of the overhang, in mm (in.), see 3-2-A3/Figure 1
- R = maximum rated RPM of the shaft
- H_p = maximum rated shaft horsepower
- V = maximum calm water speed of the craft
- SM_s = offered section modulus of the shaft, in cm^3 (in^3)
- d_s = offered diameter of the shaft, in mm (in.)
- σ_{ys} = yield strength of the shaft

5 Required Section Modulus of Strut at the Barrel

$$SM_{st} = 1000C_1[M + F_3(\ell_b \sin \phi/1000)]/\sigma_y \text{ cm}^3$$

$$SM_{st} = C_1(M + F_3\ell_b \sin \phi)/\sigma_y \text{ in}^3$$

$$C_1 = \sqrt{(C_2 / \sin \theta)^2 + (0.5 / \cos \theta)^2}$$

$$C_2 = [2 - (\ell_b/\ell_s) - (\ell_b/\ell_s)^2]/4[1 + (\ell_b/\ell_s) + (\ell_b/\ell_s)^2]$$

where

- M = the greater of M_1 or M_2 , as defined in 3-2-A3/3, in kN-m (in-lbf)
- ℓ_b = distance from center of strut barrel to the connection of the strut, in mm (in.), see 3-2-A3/Figure 1
- ϕ = cant angle of strut, in degrees, see 3-2-A3/Figure 1
- σ_y = yield strength for steel struts or the welded yield strength of aluminum struts, in kN/mm^2 (psi)
- θ = vee angle of strut in degrees, see 3-2-A3/Figure 1
- ℓ_s = distance from center of strut barrel to the hull, in mm (in.), see 3-2-A3/Figure 1

7 Required Section Modulus of Strut at the Hull

$$SM_{st} = 1000C_1[M + F_3(\ell_s \sin \phi/1000)]/\sigma_y \text{ cm}^3$$

$$SM_{st} = C_1(M + F_3\ell_s \sin \phi)/\sigma_y \text{ in}^3$$

where C_1 , M , F_3 , ℓ_s , ϕ and σ_y are as defined in 3-2-A3/5.

9 Requirements for Struts Constructed of Aluminum

The required stiffness, EI , for aluminum strut is to be 90% of a strut constructed of ABS grade A steel that meets the requirements in 3-2-A3/5 and 3-2-A3/7.

PART
3

CHAPTER **3** **Subdivision and Stability**

CONTENTS

SECTION 1	General Requirements.....	198
1	General	198
3	Criteria.....	198
3.1	Intact Stability	198
3.3	Subdivision and Damage Stability	198
5	Review Procedures	199
5.1	Administration Review	199
5.3	ABS Review	199
7	Onboard Computers for Stability Calculations	199
APPENDIX 1	Onboard Computers for Stability Calculations	200
1	General	200
1.1	Scope	200
1.3	Design	200
3	Calculation Systems	200
5	Types of Stability Software	201
7	Functional Requirements	201
7.1	Calculation Program	201
7.3	Direct Damage Stability Calculations	201
7.5	Warning	201
7.7	Data Printout	201
7.9	Date and Time	201
7.11	Information of Program	201
7.13	Units	201
9	Acceptable Tolerances	202
9.1	Calculation Program of the Approved Stability Information	202
9.3	Independent Program for Assessment of Stability	202
11	Approval Procedure	203
11.1	Conditions of Approval of the Onboard Software for Stability Calculations.....	203
11.3	General Approval (optional).....	204
11.5	Specific Approval.....	204
13	Operation Manual	205
15	Installation Testing	205
17	Periodical Testing	206
19	Other Requirements.....	206
TABLE 1	Acceptable Tolerances	203

PART

3

CHAPTER 3 Subdivision and Stability

SECTION 1 General Requirements

1 General

Craft of the following categories are to have subdivision and stability in accordance with the criteria as shown.

3 Criteria

3.1 Intact Stability

All craft which have a length of 24 m (79 ft) or over as defined in the International Convention on Load Lines are to have intact stability guidance as required by Regulation 10 of the International Convention on Load Lines. Following criteria may be used for classification purposes:

3.1.1

For all cargo craft ≥ 500 GT making voyages that are no more than 8 hours at operational speed from a place of refuge and having design speeds greater than $3.7\nabla^{1/6}$ m/sec ($7.19\nabla^{1/6}$ knots, $3.97\nabla^{1/6}$ knots) – IMO International Code of Safety for High-Speed Craft – Chapter 2.

3.1.2

For all passenger craft making voyages that are no more than 4 hours at operational speed from a place of refuge and having design speeds greater than $3.7\nabla^{1/6}$ m/sec ($7.19\nabla^{1/6}$ knots, $3.97\nabla^{1/6}$ knots) – IMO International Code of Safety for High-Speed Craft – Chapter 2

3.1.3

Other craft of all sizes – International Code on Intact Stability (2008 IS Code)

where

∇ = volumetric displacement of the vessel in the design condition in m^3 (m^3 , ft^3)

GT = the gross tonnage as defined in 3-1-1/19

In case the above criteria are not applicable to a particular craft, the intact stability will be reviewed by ABS in accordance with other recognized criteria appropriate to the craft's type, size, and intended service.

3.3 Subdivision and Damage Stability

Craft of applicable size, type, and service are to have subdivision and damage stability as required by the International Code of Safety for High-Speed Craft, or the International Convention for the Safety of Life at Sea, 1974, as amended as follows:

3.3.1

Passenger craft making voyages that are no more than 4 hours at operational speed and having design speeds greater than $3.7\nabla^{1/6}$ m/sec ($7.19\nabla^{1/6}$ knots, $3.97\nabla^{1/6}$ knots) – IMO International Code of Safety for High-Speed Craft – Chapter 2

3.3.2

Other passenger craft – SOLAS Regulation II-1/4 through 8

3.3.3

Cargo craft ≥ 500 GT making voyages that are no more than 8 hours at operation speed and having design speeds greater than $3.7\nabla^{1/6}$ m/sec ($7.19\nabla^{1/6}$ knots, $3.97\nabla^{1/6}$ knots) – IMO International Code of Safety for High-Speed Craft – Chapter 2

3.3.4

Other cargo craft ≥ 500 GT – SOLAS Regulation II-1/25-1 through 25-8

5 Review Procedures

5.1 Administration Review

When the craft is issued an International Load Line Certificate, Passenger Ship Safety Certificate, Cargo Ship Safety Construction Certificate, or High Speed Craft Safety Certificate by the flag Administration or its agent other than ABS, such Certificate will be accepted as evidence that the craft has subdivision and stability in accordance with the above criteria.

Where the Administration undertakes the review of subdivision and stability and the Bureau is issuing the above Certificate, the acceptance of subdivision and stability by the Administration will be required before the certificate is issued.

5.3 ABS Review

In all other cases the information and calculations for subdivision and stability are to be submitted to ABS for review. Where the intact stability criteria are not applicable to a particular craft, the review will be in accordance with other recognized criteria acceptable to ABS.

7 Onboard Computers for Stability Calculations

The use of onboard computers for stability calculations is not a requirement of class. However, if stability software is installed onboard craft contracted on or after 1 July 2005, it should cover all stability requirements applicable to the craft and is to be approved by ABS for compliance with the requirements of Appendix 3-3-A1, “Onboard Computers for Stability Calculations”.

CHAPTER 3 Subdivision and Stability**APPENDIX 1 Onboard Computers for Stability Calculations****1 General****1.1 Scope**

The scope of stability calculation software is to be in accordance with the stability information as approved by the flag Administration or ABS on behalf of the flag Administration. The software is at least to include all information and perform all calculations or checks as necessary to ensure compliance with the applicable stability requirements.

Approved stability software is not a substitute for the approved stability information, and is used as a supplement to the approved stability information to facilitate stability calculations.

1.3 Design

The input/output information is to be easily comparable with approved stability information so as to avoid confusion and possible misinterpretation by the operator relative to the approved stability information.

An operation manual is to be provided for the onboard computer stability software.

The language in which the stability information is displayed and printed out as well as the operation manual is written is to be the same as used in the craft's approved stability information. The primary language is to be English.

The onboard computer for stability calculations is craft specific equipment and the results of the calculations are only applicable to the craft for which it has been approved.

In case of modifications implying changes in the main data or internal arrangement of the craft, the specific approval of any original stability calculation software is no longer valid. The software is to be modified accordingly and reapproved.

3 Calculation Systems

This Appendix covers either system, a passive system that requires manual data entry or an active system, which replaces the manual with the automatic entry with sensors reading and entering the contents of tanks, etc., provided the active system is in the off-line operation mode. However, an integrated system, which controls or initiates actions based on the sensor-supplied inputs is not within the scope of this Appendix.

5 Types of Stability Software

Three types of calculations performed by stability software are acceptable depending upon a craft's stability requirements:

- Type 1 Software calculating intact stability only (for craft not required to meet a damage stability criterion)
- Type 2 Software calculating intact stability and checking damage stability on basis of a limit curve or previously approved loading conditions
- Type 3 Software calculating intact stability and damage stability by direct application of preprogrammed damage cases for each loading condition

7 Functional Requirements

7.1 Calculation Program

The calculation program is to present relevant parameters of each loading condition in order to assist the Master in his judgment on whether the craft is loaded within the approval limits. The following parameters are to be presented for a given loading condition:

- Deadweight data
- Lightship data
- Trim
- Draft at the draft marks and perpendiculars
- Summary of loading condition displacement, VCG, LCG and, if applicable, TCG
- Downflooding angle and corresponding downflooding opening
- Compliance with stability criteria: Listing of all calculated stability criteria, the limit values, the obtained values and the conclusions (criteria fulfilled or not fulfilled)

7.3 Direct Damage Stability Calculations

If direct damage stability calculations are performed, the relevant damage cases according to the applicable rules are to be pre-defined for automatic check of a given loading condition.

7.5 Warning

A clear warning is to be given on screen and in hard copy printout if any of the loading limitations are not complied with.

7.7 Data Printout

The data are to be presented on screen and in hard copy printout in a clear unambiguous manner.

7.9 Date and Time

The date and time of a saved calculation are to be part of the screen display and hard copy printout.

7.11 Information of Program

Each hard copy printout is to include identification of the calculation program with version number.

7.13 Units

Units of measurement are to be clearly identified and used consistently within a loading calculation.

9 Acceptable Tolerances

Depending on the type and scope of programs, the acceptable tolerances are to be determined differently, according to 3-3-A1/9.1 or 3-3-A1/9.3. In general, deviation from these tolerances is not to be accepted unless a satisfactory explanation for the difference is submitted for review and the same is satisfactorily confirmed by ABS that there would be no adverse effect on the safety of the craft.

Examples of pre-programmed input data include the following:

- Hydrostatic data: Displacement, LCB, LCF, VCB, KMt and MCT vs. draft
- Stability data: KN or MS values at appropriate heel/trim angles vs. displacement, stability limits.
- Compartment data: Volume, LCG, VCG, TCG and FSM heeling moments vs. level of the compartment's contents.

Examples of output data include the following:

- Hydrostatic data: Displacement, LCB, LCF, VCB, KMt and MCT versus draft, as well as actual drafts, trim.
- Stability data: FSC (free surface correction), GZ-values, KG, GM, KG/GM limits, derived stability criteria (e.g., areas under the GZ curve), weather criteria.
- Compartment data: Calculated Volume, LCG, VCG, TCG and FSM heeling moments vs. level of the compartment's contents

The computational accuracy of the calculation program results is to be within the acceptable tolerances specified in 3-3-A1/9.1 or 3-3-A1/9.3, of the results using an independent program or the approved stability information with identical input.

9.1 Calculation Program of the Approved Stability Information

Programs which use only pre-programmed data from the approved stability information as the basis for stability calculations are to have zero tolerances for the printouts of input data.

Output data tolerances are to be close to zero. However, small differences associated with calculation rounding or abridged input data are acceptable. Additionally differences associated with the use of hydrostatic and stability data for trims that differ from those in the approved stability information are acceptable subject to review by ABS.

9.3 Independent Program for Assessment of Stability

Programs which use hull form models as their basis for stability calculations are to have tolerances for the printouts of basic calculated data established against either data from the approved stability information or data obtained using the approval authority's model. Acceptable tolerances shall be in accordance with 3-3-A1/Table 1.

TABLE 1
Acceptable Tolerances

<i>Hull Form Dependent</i>	<i>Acceptable Tolerance ⁽¹⁾</i>
Displacement	2%
Longitudinal center of buoyancy, from AP	1%/50 cm max
Vertical center of buoyancy	1%/5 cm max
Transverse center of buoyancy	0.5% of B/5 cm max
Longitudinal center of flotation, from AP	1%/50 cm max
Moment to trim 1 cm	2%
Transverse metacentric height	1%/5 cm max
Longitudinal metacentric height	1%/50cm max
Cross curves of stability	5 cm
<i>Compartment Dependent</i>	
Volume or deadweight	2%
Longitudinal center of gravity, from AP	1%/50 cm max
Vertical centre of gravity	1%/5 cm max
Transverse center of gravity	0.5% of B/5 cm max
Free surface moment	2%
Shifting moment	5%
Level of contents	2%
<i>Trim and Stability</i>	
Drafts (forward, aft, mean)	1%/5 cm max
GMt	1%/5 cm max
GZ values	1%/5 cm max
FS correction	2%
Downflooding angle	2°
Equilibrium angles	1°
Distance to unprotected openings or margin line from WL, if applicable	±5%/5 cm max
Areas under righting arm curve	5% or 0.0012 mrad

Notes:

- 1 Deviation in % = [(base value – applicant’s value)/base value] × 100.
 where the “base value” may be from the approved stability information or the results of master computer using an independent program.

11 Approval Procedure

11.1 Conditions of Approval of the Onboard Software for Stability Calculations (1 July 2012)

The onboard software used for stability calculations is subject to approval, which is to include:

- Verification of type approval, if any,
- Verification that the data used is consistent with the current condition of the craft (see 3-3-A1/11.5),
- Verification and approval of the test conditions, and
- Verification that the software is appropriate for the type of craft and stability calculations required.

- Verification that the software is installed so that failure of the primary computer or server does not prevent the stability calculation from being carried out (this is to be demonstrated onboard as noted below)

The satisfactory operation of the software for stability calculations is to be verified by testing upon installation on the primary computer or server and at least one back-up computer or redundant server onboard (see 3-3-A1/15). A copy of the approved test conditions and the operation manual for the computer/software are to be available onboard.

11.3 General Approval (optional)

Upon receipt of application for general approval of the calculation program, ABS may provide the applicant with test data consisting of two or more design data sets, each of which is to include a craft's hull form data, compartmentation data, lightship characteristics and deadweight data, in sufficient detail to accurately define the craft and its loading condition.

Acceptable hull form and compartmentation data may be in the form of surface coordinates for modeling the hull form and compartment boundaries (e.g., a table of offsets) or in the form of pre-calculated tabular data (e.g., hydrostatic tables, capacity tables) depending upon the form of data used by the software being submitted for approval. Alternatively, the general approval may be given based on at least two test craft agreed upon between the applicant and ABS.

In general, the software is to be tested for two types of craft for which approval is requested, with at least one design data set for each of the two types. Where approval is requested for only one type of craft, a minimum of two data sets for different hull forms of that type of craft are required to be tested.

For calculation software which is based on the input of hull form data, design data sets are to be provided for three types of craft for which the software is to be approved, or a minimum of three data sets for different hull forms if approval is requested for only one type of craft. Representative craft are those types which, due to their different hull forms, typical arrangements and nature of cargo, require different design data sets.

The test data sets are to be used by the applicant to run the calculation program for the test craft. The results obtained, together with the hydrostatic data and cross-curve data developed by the program, if appropriate are to be submitted to ABS for the assessment of the program's computational accuracy. ABS is to perform parallel calculations using the same data sets and a comparison of these results will be made against the applicant's submitted program's results.

11.5 Specific Approval

ABS is to verify the accuracy of the computational results and actual craft data used by the calculation program for the particular craft on which the program will be installed.

Upon receipt of application for data verification, ABS and the applicant are to agree on a minimum of four loading conditions, taken from the craft's approved stability information, which are to be used as the test conditions.

For craft carrying liquids in bulk, at least one of the conditions is to include partially filled tanks. Within the test conditions each compartment is to be loaded at least once. The test conditions normally are to cover the range of load drafts from the deepest envisaged loaded condition to the light ballast condition and are to include at least one departure and one arrival condition.

ABS is to verify that the following data, submitted by the applicant, is consistent with arrangements and most recently approved lightship characteristics of the craft according to current plans and documentation on file with ABS, subject to possible further verification onboard:

- Identification of the calculation program including version number.
- Main dimensions, hydrostatic particulars and, if applicable, the craft profile.
- The position of the forward and after perpendiculars, and if appropriate, the calculation method to derive the forward and after drafts at the actual position of the craft's draft marks.
- Craft lightweight and center of gravity derived from the most recently approved inclining experiment or light weight check.

- Lines plan, offset tables or other suitable presentation of hull form data if necessary for ABS to model the craft.
- Compartment definitions, including frame spacing, and centers of volume, together with capacity tables (sounding/ullage tables), free surface corrections, if appropriate
- Cargo and Consumables distribution for each loading condition.

Verification by ABS does not absolve the applicant and craft owner of responsibility for ensuring that the information programmed into the onboard computer software is consistent with the current condition of the craft.

13 Operation Manual

A simple and straightforward operation manual is to be provided, containing descriptions and instructions, as appropriate, for at least the following:

- Installation
- Function keys
- Menu displays
- Input and output data
- Required minimum hardware to operate the software
- Use of the test loading conditions
- Computer-guided dialogue steps
- List of warnings

15 Installation Testing

To ensure correct working of the computer after the final or updated software has been installed, it is the responsibility of the craft's master to have test calculations carried out according to the following pattern in the presence of the Surveyor:

- From the approved test conditions at least one load case (other than lightship) is to be calculated.
Note: Actual loading condition results are not suitable for checking the correct working of the computer.
- Normally, the test conditions are permanently stored in the computer.

Steps to be performed:

- Retrieve the test load case and start a calculation run; compare the stability results with those in the documentation.
- Change several items of deadweight (tank weights and the cargo weight) sufficiently to change the draft or displacement by at least 10%. The results are to be reviewed to ensure that they differ in a logical way from those of the approved test condition.
- Revise the above modified load condition to restore the initial test condition and compare the results. The relevant input and output data of the approved test condition are to be replicated.
- Alternatively, one or more test conditions shall be selected and the test calculation performed by entering all deadweight data for each selected test condition into the program as if it were a proposed loading. The results shall be verified as identical to the results in the approved copy of the test conditions.

17 Periodical Testing

It is the responsibility of the craft's master to check the accuracy of the onboard computer for stability calculations at each Annual Survey by applying at least one approved test condition.

If the Surveyor is not present for the computer check, a copy of the test condition results obtained by the computer check is to be retained onboard as documentation of satisfactory testing for the Surveyor's verification.

At each Special Periodical Survey, this checking for all approved test loading conditions is to be done in presence of the surveyor.

The testing procedure is to be carried out in accordance with 3-3-A1/15.

19 Other Requirements

The following features are to be provided to the software:

- Protection against unintentional or unauthorized modification of programs and data is to be provided.
- The program is to monitor operations and activate an alarm when the program is incorrectly or abnormally used.
- The program and any data stored in the system are to be protected from corruption by loss of power.
- Error messages with regard to limitations such as filling a compartment beyond capacity, or exceeding the assigned load line, etc. are to be included.

PART
3

CHAPTER **4** **Fire Safety Measures**

CONTENTS

SECTION 1	Structural Fire Protection.....	208
1	General	208
1.1	SOLAS Application.....	208
1.3	Regulation	208
1.5	Definitions.....	208
1.7	Materials Containing Asbestos	208
3	Passenger Craft	208
5	Cargo Craft	208
7	Review Procedures	209
7.1	Administration Review	209
7.3	ABS Review	209
9	The Review of Craft Constructed of Fiber Reinforced Plastic (FRP)	209

PART

3

CHAPTER 4 Fire Safety Measures

SECTION 1 Structural Fire Protection

1 General

1.1 SOLAS Application

For classification purposes, the fire and safety measures contained in the International Convention for the Safety of Life at Sea, 1974 (1974 SOLAS), as amended, are applicable to vessels of type, size and service coming under that Convention. This includes the IMO International Code of Safety for High-Speed Craft (HSC Code), incorporated as Chapter X of 1974 SOLAS, as applicable.

This section does not relax the requirements in other sections of the Rules.

Gross tonnage is to be taken as defined in 3-1-1/19.

1.3 Regulation

Regulation means the regulation contained in 1974 SOLAS, as amended. An abbreviated notation is used, e.g., Regulation II-2/5.2 means Regulation 5.2 of Chapter II-2.

1.5 Definitions

See Regulation II-2/3.

1.7 Materials Containing Asbestos

Installation of materials which contain asbestos is prohibited.

3 Passenger Craft

For passenger craft as defined in 1.1 through 1.4 of the HSC Code, the requirements in 7.1 through 7.6 HSC Code is applicable. See also Part 5 Chapter 1.

For all passenger craft subject to 1974 SOLAS as amended, the requirements in Part B, Chapter II-2 are applicable. See also the ABS Guide for Building and Classing Passenger Vessels

5 Cargo Craft

For cargo craft as defined in 1.1 through 1.4 of the HSC Code, the fire and safety measures contained in Chapter 7 of the IMO International Code of Safety for High-Speed Craft (2000 HSC Code) are applicable.

For all cargo craft subject to 1974 SOLAS as amended, and are defined in Regulation II-2/3.7, the relevant requirements in Part B: Regulation 4, 5, 6; Part C: Regulations 7, 8, 9, 10, 11; Part D: Regulation 13; and Part G: Regulations 19 and 20, Chapter II-2 are applicable.

7 Review Procedures

7.1 Administration Review

When the vessel is issued a Passenger Ship Safety Certificate, Cargo Ship Safety Equipment Certificate or Cargo Ship Safety Construction Certificate by the flag Administration or its agent other than ABS, such Certificate will be accepted as evidence that the vessel is in accordance with the applicable criteria in 1974 SOLAS, as amended.

Where the Administration undertakes any part of the review and ABS is issuing the above Certificate, the acceptance by the Administration will be required before the certificate is issued.

Compliance with the Rule requirements, in addition to those in 1974 SOLAS, as amended, is to be verified by ABS.

7.3 ABS Review

In all other cases, the required information and plans are to be submitted to ABS for review.

9 The Review of Craft Constructed of Fiber Reinforced Plastic (FRP)

FRP fire-restricting divisions may be considered provided they meet the required tests for fire-restricting materials and fire-resisting divisions, or comply with an acceptable fire risk assessment. FRP divisions may also be considered on the basis of location with regard to diminished fire risk and enhanced fire detection/extinguishing means.

PART
3

CHAPTER **5 Equipment**

CONTENTS

SECTION 1	Anchoring, Mooring and Towing Equipment	212
1	General	212
3	Calculation of EN	212
3.1	Monohulls	212
3.3	Multi-Hulled Craft	214
5	Equipment, Weight and Size	214
5.1	Alternatives for Anchor Size	214
5.3	Wire Rope	214
5.5	Synthetic Fiber Rope	215
7	Materials and Tests	215
9	Anchor Types	215
9.1	General	215
9.3	High Holding Power Anchors (HHP)	215
9.5	Super High Holding Power Anchors (SHHP)	215
11	Windlass Support Structure and Cable Stopper	215
11.1	General	215
11.3	Support Structure	216
11.5	Craft Less Than 61 m (200 ft) in Length	219
13	Trial	219
15	Hawse Pipes	219
17	Hawsers and Towlines	219
19	Bollard, Fairlead and Chocks	220
19.1	General	220
19.3	Deck Fittings	220
19.5	Safe Working Load (SWL)	220
19.7	Towing and Mooring Arrangements Plan	221
TABLE 1	Equipment for Self-propelled Ocean-going Craft	222
TABLE 2	Towline and Hawsers for Self-propelled Ocean-going Vessels	226
FIGURE 1A	Effective Heights of Deck Houses – Monohulls	213
FIGURE 1B	Effective Heights of Deck Houses – Multi-Hulled Craft	214
FIGURE 2	Direction of Forces and Weight	218
FIGURE 3	Sign Convention	219

APPENDIX 1	Alternative Standard for the Required Anchor Size.....	230
1	General	230
3	Anchor Size Requirement.....	230
5	Anchor Chain, Cable, or Rope	230

PART

3

CHAPTER 5 Equipment

SECTION 1 Anchoring, Mooring and Towing Equipment

1 General

All craft are to have a complete equipment of anchor(s) and chains. The letter $\text{\textcircled{E}}$ placed after the symbols of classification in the *Record*, thus: $\text{\textcircled{A1 E}}$, will signify that the equipment of the craft is in compliance with the requirements of this Guide, and tested in accordance with 3-5-1/7, or with requirements, which have been specially approved for the particular service.

Cables which are intended to form part of the equipment are not to be used as deck chains when the craft is launched. The inboard ends of the cables of the bower anchors are to be secured by efficient means. Anchors and their cables are to be connected and positioned, ready for use. Where three anchors are given in 3-5-1/Table 1, the third anchor is intended as a spare anchor and is listed for guidance only; it is not required as a condition of classification. Means are to be provided for stopping each cable as it is paid out, and the windlass should be capable of heaving in either cable. Suitable arrangements are to be provided for securing the anchors and stowing the cables.

Equipment Number calculations for unconventional vessels with unique topside arrangements or operational profiles may be specially considered. Such consideration may include accounting for additional wind areas of widely separated deckhouses or superstructures in the equipment number calculations or equipment sizing based on direct calculations. However, in no case may direct calculations be used to reduce the equipment size to be less than that required by 3-5-1/3.

3 Calculation of EN

3.1 Monohulls

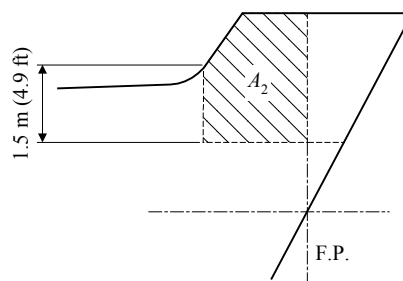
The basic Equipment Number (EN) is to be obtained from the following equation for use in determining required equipment.

$$EN = k\Delta^{2/3} + m(Ba + \Sigma bh) + nA$$

where

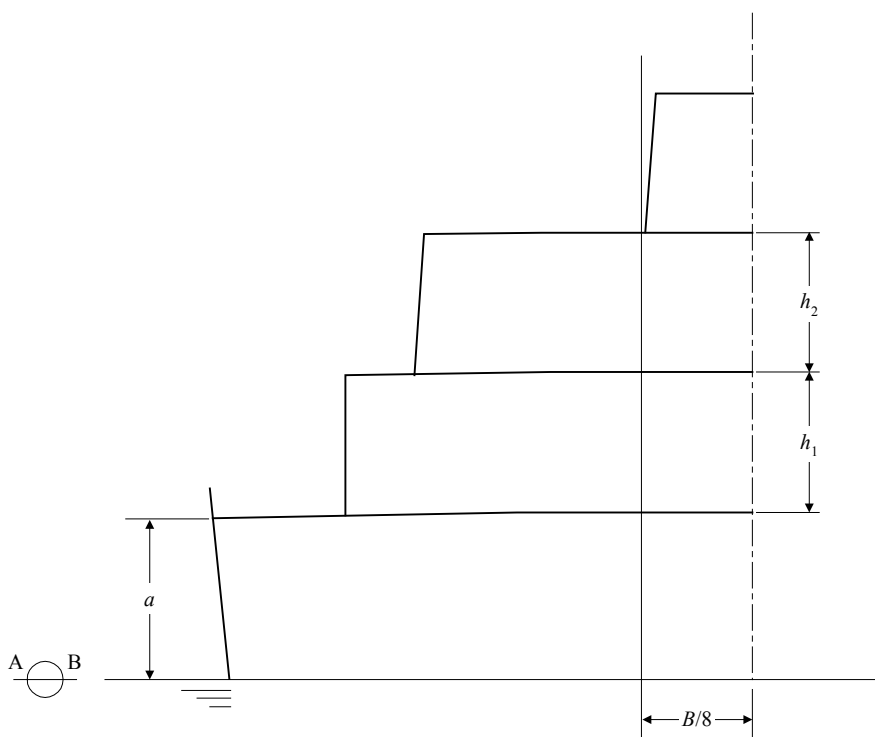
- k = 1.0 (1.0, 1.012)
- m = 2 (2, 0.186)
- n = 0.1 (0.1, 0.00929)
- Δ = molded displacement, in metric tons (long tons), at the summer load waterline.
- B = molded breadth, as defined in 3-1-1/5, in m (ft)
- h = h_1, h_2, h_3, \dots as shown in 3-5-1/Figure 1A. In the calculation of h , sheer, camber and trim may be neglected.
- a = freeboard, in m (ft), from the light waterline amidships.
- h_1, h_2, h_3, \dots = height, in m (ft), on the centerline of each tier of houses having a breadth greater than $B/4$.

A = profile area, in m^2 (ft^2), of the hull, superstructure and houses above the summer load waterline which are within L (see 3-1-1/3). Superstructures or deckhouses having a breadth at any point no greater than $0.25B$ may be excluded. Screens and bulwarks more than 1.5 m (4.9 ft) in height are to be regarded as parts of houses when calculating h and A . The height of the hatch coamings and that of any deck cargo, such as containers, may be disregarded when determining h and A . With regard to determining A , when a bulwark is more than 1.5 m (4.9 ft) high, the area shown below as A_2 should be included in A .



b = breadth, in m (ft), of the widest superstructure or deckhouse on each tier.

FIGURE 1A
Effective Heights of Deck Houses – Monohulls



3.3 Multi-Hulled Craft

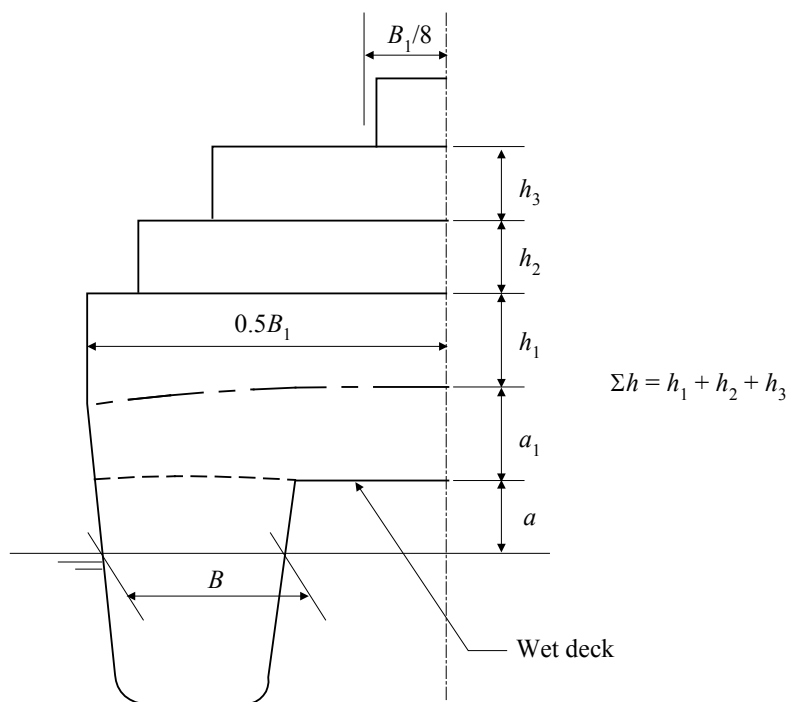
Anchors and chains are to be not less than given in 3-5-1/Table 1 and the numbers, weights and sizes of these are to be based on the equipment number obtained from the following equation. Special consideration will be given where anchoring and mooring conditions are specified.

$$\text{Equipment Number} = 2k \left(\frac{\Delta}{2} \right)^{2/3} + m[(2Ba) + B_1(a_1 + \Sigma h)] + nA$$

k , Δ , m , n and A are defined in 3-5-1/3.1.

B , B_1 , a , a_1 , h_1 , h_2 , h_3 , Σh are shown in 3-5-1/Figure 1B.

FIGURE 1B
Effective Heights of Deck Houses – Multi-Hulled Craft



5 Equipment, Weight and Size

The equipment, weight and size of all craft is to be in accordance with 3-5-1/Table 1, in association with the EN calculated in 3-5-1/3.

5.1 Alternatives for Anchor Size

The requirements for anchor sizing given in 3-5-Appendix 1 may be used in lieu of the anchor size and number given by 3-5-1/Table 1. The requirements in 3-5-1/9 are not applicable when the alternative anchor sizing requirements are used. Where one anchor is required by using the alternative arrangement, the total length of chain required is one-half the value given in 3-5-1/Table 1.

5.3 Wire Rope

Wire rope may be used in lieu of chain. The wire is to have a breaking strength not less than the grade 1 chain of required size and a length of at least 1.5 times the chain it is replacing. Between the wire rope and anchor, chain cable of the required size and having a length of 12.5 m (41.0 ft), or the distance between the anchor in the stored position and winch, whichever is less, is to be fitted.

5.5 Synthetic Fiber Rope

Synthetic fiber rope may be used in lieu of anchor chain cable provided the craft meets the following:

- i) The craft is less than 54 m (175 ft) in length.
- ii) A length of chain is to be fitted between the anchor and synthetic fiber line.
- iii) The chain is not to be less than the required Grade 1 chain for the equipment number.
- iv) The chain length is to be at least the distance between the windlass and the anchor in the stowed position and not less than $0.2L$ meters (feet).
- v) The ropes are to be stowed on drums or lockers, protected from the weather and sea, and are to be lead over rollers.
- vi) The rope length is to be at least 1.5 times the required chain length.
- vii) The breaking strength of the rope is to be at least equal to the breaking strength of the required Grade 1 chain cable.
- viii) Synthetic fiber ropes for this application are to be polyimide fiber rope or equivalent. Polypropylene rope is not to be used.
- ix) If the anchors are HHP or SHHP, the combined cable/synthetic rope is to be adequate for the verified holding power of the anchor.

7 Materials and Tests

Material and testing for anchors and chains on craft are to be in accordance with the requirements of Part 2, Chapter 2 for the respective sizes of anchors and chains. See Sections 2-2-1 and 2-2-2. Materials and tests for wire rope are to be in accordance with a national or other recognized standard.

9 Anchor Types

9.1 General

Anchors are in general to be of the stockless type. The weight of the head of a stockless anchor, including pins and fittings, is not to be less than three-fifths of the total weight of the anchor.

9.3 High Holding Power Anchors (HHP)

Where the anchor has a proven holding power of not less than two times that of an ordinary stockless anchor and has been tested in accordance with Section 2-2-1 a weight reduction of 25% from the weight specified in 3-5-1/Table 1 will be given. For **HHP** anchors an appropriate notation will be made in the *Record*.

9.5 Super High Holding Power Anchors (SHHP)

Where the anchor has a proven holding power of not less than four times that of an ordinary stockless anchor and has been tested in accordance with Section 2-2-1 a weight reduction of 50% from the weight specified in 3-5-1/Table 1 will be given. For **SHHP** anchors an appropriate notation will be made in the *Record*.

11 Windlass Support Structure and Cable Stopper

11.1 General

The windlass is to be of good and substantial make suitable for the size of intended anchor cable. The winch is to be well bolted down to a substantial bed, and deck beams below the windlass are to be of extra strength and additionally supported. Where wire ropes are used in lieu of chain cables, winches capable of controlling the wire rope at all times are to be fitted.

Construction and installation of all windlasses and winches used for anchoring are to be carried out in accordance with the following requirements, to the satisfaction of the Surveyor. In general, the design is to conform to an applicable standard or code of practice. As a minimum, standards or practices are to indicate strength, performance and testing criteria.

For vessels with length, L (as defined in 3-1-1/3), over 80 meters (263 feet) the windlass supporting structures located on the exposed fore deck within the forward $0.25L$ are to meet the requirements in 3-5-1/11.3. Where the mooring winch is integral with the windlass, it is to be considered as a part of the windlass for the purpose of said paragraph.

The manufacturer or builder is to submit in accordance with 4-1-1/7, the following, as applicable:

11.1.1 Plans

- i) Arrangement and details of the windlass or winch, drums, brakes, shaft, gears, coupling bolts, wildcat, sheaves, pulleys and foundation.
- ii) Electric one line diagram
- iii) Piping system diagrams
- iv) Control arrangements.

Plans or data are to show complete details including power ratings, working pressures, welding details, material specifications, pipe and electric cable specifications, etc.

11.1.2 Calculations

Detailed stress calculations for the applicable system components listed in 3-5-1/11.1.1i) above. The calculations are to be based on the breaking strength of the chain or wire rope; are to indicate maximum torque or load to which the unit will be subjected and also show compliance with either applicable sections of the Rules, such as Section 4-3-1 and Appendix 4-3-1A1 for the gears and shafts, or to other recognized standard or code of practice.

11.3 Support Structure

The windlass is to be bolted down to a substantial foundation, which is to meet the following load cases and associated criteria.

An independent cable stopper and its components are to be adequate for the load imposed. The arrangements and details of the cable stopper are to be submitted for review.

11.3.1 Operating Loads

11.3.1(a) Load on Windlass Support Structure. The following load is to be applied in the direction of the chain.

With cable stopper not attached to windlass: 45% of B.S.

With cable stopper attached to windlass: 80% of B.S.

Without cable stopper: 80% of B.S.

B.S. = minimum breaking strength of the chain, as indicated in 2-2-2/Tables 2 and 3 of the *Rules for Materials and Welding (Part 2)*.

11.3.1(b) Load on Cable Stopper and Support Structure. A load of 80% of B.S. is to be applied in the direction of the chain.

11.3.1(c) Allowable Stress. The stresses in the structures supporting the windlass and cable stopper are not to exceed the yield point.

11.3.2 Sea Loads

11.3.2(a) *Pressures.* The following pressures and associated areas are to be applied (see 3-5-1/Figure 2):

- 200 kN/m² (20.4 tf/m², 4178 lbs/ft²) normal to the shaft axis and away from the forward perpendicular, over the projected area in this direction,
- 150 kN/m² (15.3 tf/m², 3133 lbs/ft²) parallel to the shaft axis and acting both inboard and outboard separately, over the multiple of f times the projected area in this direction,

where f is defined as:

$$f = 1 + B/H, f \text{ need not be taken as greater than } 2.5$$

$$B = \text{width of windlass measured parallel to the shaft axis}$$

$$H = \text{overall height of windlass.}$$

11.3.2(b) *Forces.* Forces in the bolts, chocks and stoppers securing the windlass to the deck are to be calculated. The windlass is supported by N groups of bolts, each containing one or more bolts, see 3-5-1/Figure 2.

i) *Axial Forces.* The aggregate axial force R_i in respective group of bolts (or bolt) i , positive in tension, may be calculated from the following equations:

$$R_{xi} = P_x h x_i A_i / I_x$$

$$R_{yi} = P_y h y_i A_i / I_y$$

and

$$R_i = R_{xi} + R_{yi} - R_{si}$$

where

- P_x = force, kN (tf, lbs), acting normal to the shaft axis
- P_y = force, kN (tf, lbs), acting parallel to the shaft axis, either inboard or outboard, whichever gives the greater force in bolt group i
- h = shaft height above the windlass mounting, cm (in.)
- x_i, y_i = x and y coordinates of bolt group i from the centroid of all N bolt groups, positive in the direction opposite to that of the applied force, cm (in.)
- A_i = cross sectional area of all bolts in group i , cm² (in²)
- I_x = $A_i x_i^2$ for N bolt groups
- I_y = $A_i y_i^2$ for N bolt groups
- R_{si} = static reaction at bolt group i , due to weight of windlass.

ii) *Shear forces.* Aggregated shear forces, F_{xi} , F_{yi} , applied to the respective bolt group, i , of bolts, and the resultant combined force, F_i , may be calculated from:

$$F_{xi} = (P_x - \alpha g M) / N$$

$$F_{yi} = (P_y - \alpha g M) / N$$

and

$$F_i = (F_{xi}^2 + F_{yi}^2)^{0.5}$$

where:

- α = coefficient of friction (0.5)
- M = mass of windlass, in tonnes (Ltons)
- g = gravity: 9.81 m/sec² (32.2 ft/sec²)
- N = number of groups of bolt.

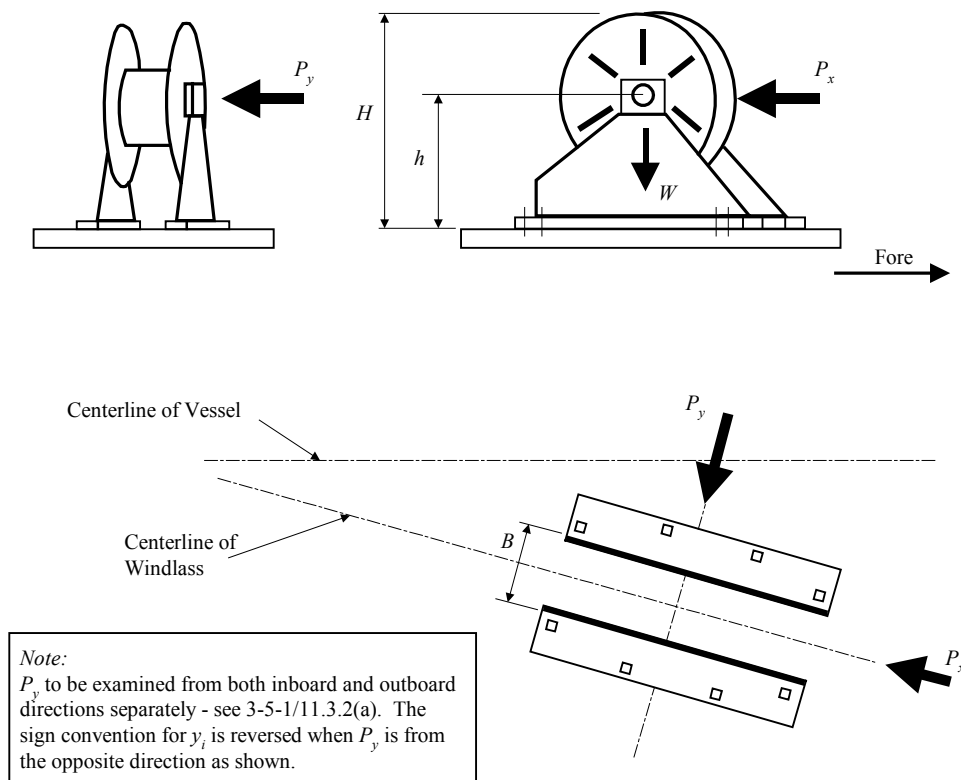
The axial tensile/compressive and lateral forces from the above equations are also to be considered in the design of the supporting structure.

11.3.2(c) *Stresses in Bolts.* Tensile axial stresses in the individual bolts in each group of bolts, i , are to be calculated. The horizontal forces, F_{xi} and F_{yi} , are normally to be reacted by shear chocks. Where “fitted” bolts are designed to support these shear forces in one or both directions, the von Mises equivalent stresses in the individual “fitted” bolts are to be calculated, and compared to the stress under proof load. Where pour-able resins are incorporated in the holding down arrangements, due account is to be taken in the calculations.

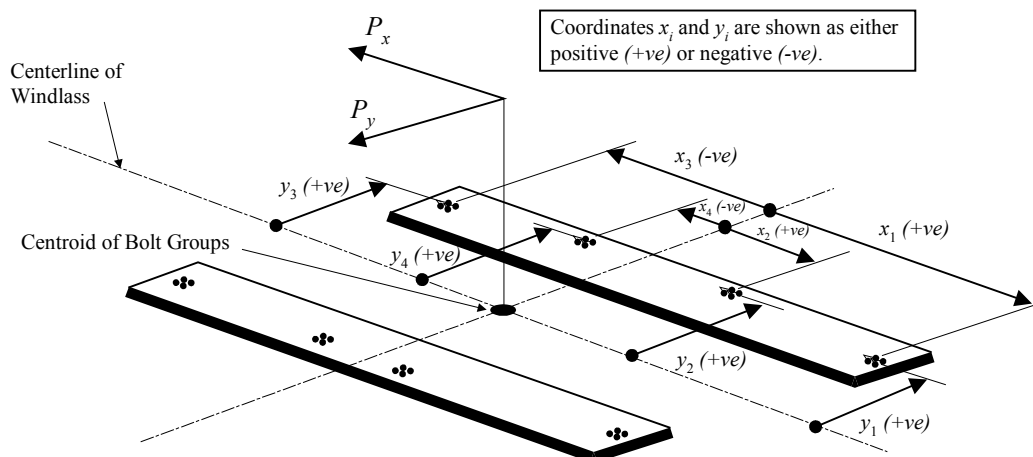
11.3.2(d) *Allowable Stress*

- i) *Bolts.* The safety factor against bolt proof strength is to be not less than 2.0.
- ii) *Supporting Structures.* The stresses in the above deck framing and the hull structure supporting the windlass are not to exceed the following value.
 - Bending Stress 85% of the yield strength of the material
 - Shearing Stress 60% of the yield strength of the material

FIGURE 2
Direction of Forces and Weight



**FIGURE 3
 Sign Convention**



11.5 Craft Less Than 61 m (200 ft) in Length

Where it is not practical to fit an anchor windlass or winch that has been approved by ABS in accordance with 3-5-1/11.1, consideration will be given to fitting an anchor windlass that is provided with a certificate from the manufacturer. This certificate is to state that the equipment has been designed to accommodate the breaking strength of the required chain or wire rope. If the required anchor weight is less than 38.5 kg (85 lbs) no winch or windlass is required.

13 Trial

See 3-7-2/1.

15 Hawse Pipes

Hawse pipes are to be of ample size and strength; they are to have full rounded flanges and the least possible lead, in order to minimize the nip on the cables; they are to be securely attached to thick doubling or insert plates by continuous welds the size of which are to be in accordance with Section 3-2-13 for the plating thickness and type of joint selected. When in position they are to be thoroughly tested for watertightness by means of a hose in which the water pressure is not to be less than 2.06 bar (2.1 kgf/cm², 30 psi). Hawse pipes for stockless anchors are to provide ample clearances; the anchors are to be shipped and unshipped so that the Surveyor may be satisfied that there is no risk of the anchor jamming in the hawse pipe. Care is to be taken to ensure a fair lead for the chain from the windlass to the hawse pipes and to the chain pipes.

17 Hawsers and Towlines

Hawsers and towlines are not required as a condition of classification. The hawsers and towlines listed in 3-5-1/Table 2 are intended as a guide. Where the tabular breaking strength exceeds 490 kN (50,000 kgf, 110,200 lbf), the breaking strength and the number of individual hawsers given in the Table may be modified, provided their product is not less than that of the breaking strength and the number of hawsers given in the Table. For vessels having an A/EN ratio greater than 0.9 for metric units (9.7 for US units), the number of hawsers given in 3-5-1/Table 2 is to be increased by the number given below.

<i>A/EN Ratio</i>		
<i>SI Units, Metric Units</i>	<i>U.S. Units</i>	<i>Increase number of hawsers by</i>
above 0.9 up to 1.1	above 9.7 up to 11.8	1
above 1.1 up to 1.2	above 11.8 up to 12.9	2
above 1.2	above 12.9	3

where

- A = defined in 3-5-1/3
- EN = determined by the equation in 3-5-1/3

19 Bollard, Fairlead and Chocks

19.1 General

The arrangements and details below are for guidance only and are not required for class. The guidance for the supporting structures of these deck fittings are specified in 3-2-7/4 of the *Steel Vessel Rules*.

19.3 Deck Fittings

The size of deck fittings is to be in accordance with recognized standards (e.g., ISO3913 Shipbuilding Welded Steel Bollards). The design load used to assess deck fittings and their attachments to the hull are to be in accordance with the requirements as specified in 3-2-7/4 of the *Steel Vessel Rules*.

19.5 Safe Working Load (SWL)

The requirements on SWL apply for a single post basis (no more than one turn of one cable).

19.5.1 Mooring Operations

The SWL is not to exceed 80% of the design load per 3-2-7/4.3 of the *Steel Vessel Rules*.

19.5.2 Towing Operations

The SWL used for normal towing operations (e.g., harbor/maneuvering) is not to exceed 80% of the design load per 3-2-7/4.3.2(a) of the *Steel Vessel Rules* and the SWL used for other towing operations (e.g., escort) is not to exceed the design load per 3-2-7/4.3.2(b) of the *Steel Vessel Rules*. For deck fittings used for both normal and other towing operations, the design load of 3-2-7/4.3.2 of the *Steel Vessel Rules* is to be used.

19.5.3 Marking and Plan

19.5.3(a) Marking. The SWL of each deck fitting is to be marked (by weld bead or equivalent) on the deck fittings used for towing/mooring.

19.5.3(b) Plan. The towing and mooring arrangements plan mentioned in 3-5-1/19.7 is to define the method of use of mooring lines and/or towing lines.

19.7 Towing and Mooring Arrangements Plan

The SWL for the intended use for each deck fitting is to be noted in the towing and mooring arrangements plan available on board for the guidance of the Master.

Information provided on the plan is to include in respect of each deck fitting:

- Location on the ship
- Fitting type
- SWL
- Purpose (mooring/harbor towing/escort towing)
- Manner of applying towing or mooring line load including limiting fleet angles.

Note: Where the arrangements and details of deck fittings and their supporting structures are designed based on the mooring arrangements as permitted in Note 2 of 3-2-7/4.3.1(a) of the *Steel Vessel Rules*, the arrangement of mooring lines showing number of lines together with the breaking strength of each mooring line are to be clearly indicated on the plan.

This information is to be incorporated into the pilot card in order to provide the pilot proper information on harbor/escorting operations.

TABLE 1
Equipment for Self-propelled Ocean-going Craft

SI, MKS Units							
The weight per anchor of bower anchors given in 3-5-1/Table 1 is for anchors of equal weight. The weight of individual anchors may vary 7% plus or minus from the tabular weight provided that the combined weight of all anchors is not less than that required for anchors of equal weight. The total length of chain required to be carried on board, as given in 3-5-1/Table 1, is to be reasonably divided between the two bower anchors. Where three anchors are given in 3-5-1/Table 1, the third anchor is intended as spare bower anchor and is listed for guidance only; it is not required as a condition of classification.							
Equipment Numeral	Equipment Number*	Stockless Bower Anchors		Chain Cable Stud Link Bower Chain			
		Number	Mass per Anchor, kg	Length, m	Diameter		
					Normal-Strength Steel (Grade 1), mm	High-Strength Steel (Grade 2), mm	Extra High-Strength Steel (Grade 3), mm
UA1	30	2	75	192.5	12.5	—	—
UA2	40	2	100	192.5	12.5	—	—
UA3	50	2	120	192.5	12.5	—	—
UA4	60	2	140	192.5	12.5	—	—
UA5	70	2	160	220	14	12.5	—
UA6	80	2	180	220	14	12.5	—
UA7	90	2	210	220	16	14	—
UA8	100	2	240	220	16	14	—
UA9	110	2	270	247.5	17.5	16	—
UA10	120	2	300	247.5	17.5	16	—
UA11	130	2	340	275	19	16	—
UA12	140	2	390	275	20.5	17.5	—
U6	150	2	480	275	22	19	—
U7	175	2	570	302.5	24	20.5	—
U8	205	3	660	302.5	26	22	20.5
U9	240	3	780	330	28	24	22
U10	280	3	900	357.5	30	26	24
U11	320	3	1020	357.5	32	28	24
U12	360	3	1140	385	34	30	26
U13	400	3	1290	385	36	32	28
U14	450	3	1440	412.5	38	34	30
U15	500	3	1590	412.5	40	34	30
U16	550	3	1740	440	42	36	32
U17	600	3	1920	440	44	38	34
U18	660	3	2100	440	46	40	36
U19	720	3	2280	467.5	48	42	36
U20	780	3	2460	467.5	50	44	38
U21	840	3	2640	467.5	52	46	40
U22	910	3	2850	495	54	48	42
U23	980	3	3060	495	56	50	44
U24	1060	3	3300	495	58	50	46
U25	1140	3	3540	522.5	60	52	46
U26	1220	3	3780	522.5	62	54	48
U27	1300	3	4050	522.5	64	56	50
U28	1390	3	4320	550	66	58	50
U29	1480	3	4590	550	68	60	52
U30	1570	3	4890	550	70	62	54

TABLE 1 (continued)
Equipment for Self-propelled Ocean-going Craft

SI, MKS Units							
Equipment Numeral	Equipment Number*	Stockless Bower Anchors		Chain Cable Stud Link Bower Chain			
		Number	Mass per Anchor, kg	Length, m	Diameter		
					Normal- Strength Steel (Grade 1), mm	High- Strength Steel (Grade 2), mm	Extra High- Strength Steel (Grade 3), mm
U31	1670	3	5250	577.5	73	64	56
U32	1790	3	5610	577.5	76	66	58
U33	1930	3	6000	577.5	78	68	60
U34	2080	3	6450	605	81	70	62
U35	2230	3	6900	605	84	73	64
U36	2380	3	7350	605	87	76	66
U37	2530	3	7800	632.5	90	78	68
U38	2700	3	8300	632.5	92	81	70
U39	2870	3	8700	632.5	95	84	73
U40	3040	3	9300	660	97	84	76
U41	3210	3	9900	660	100	87	78
U42	3400	3	10500	600	102	90	78
U43	3600	3	11100	687.5	105	92	81
U44	3800	3	11700	687.5	107	95	84
U45	4000	3	12300	687.5	111	97	87
U46	4200	3	12900	715	114	100	87
U47	4400	3	13500	715	117	102	90
U48	4600	3	14100	715	120	105	92
U49	4800	3	14700	742.5	122	107	95
U50	5000	3	15400	742.5	124	111	97
U51	5200	3	16100	742.5	127	111	97
U52	5500	3	16900	742.5	130	114	100
U53	5800	3	17800	742.5	132	117	102
U54	6100	3	18800	742.5	—	120	107
U55	6500	3	20000	770	—	124	111
U56	6900	3	21500	770	—	127	114
U57	7400	3	23000	770	—	132	117
U58	7900	3	24500	770	—	137	122
U59	8400	3	26000	770	—	142	127
U60	8900	3	27500	770	—	147	132
U61	9400	3	29000	770	—	152	132
U62	10000	3	31000	770	—	—	137
U63	10700	3	33000	770	—	—	142
U64	11500	3	35500	770	—	—	147
U65	12400	3	38500	770	—	—	152
U66	13400	3	42000	770	—	—	157
U67	14600	3	46000	770	—	—	162

* For intermediate values of equipment number use equipment complement in sizes and weights given for the lower equipment number in the table.

TABLE 1
Equipment for Self-propelled Ocean-going Craft

US Units							
The weight per anchor of bower anchors given in 3-5-1/Table 1 is for anchors of equal weight. The weight of individual anchors may vary 7% plus or minus from the tabular weight, provided that the combined weight of all anchors is not less than that required for anchors of equal weight. The total length of chain required to be carried onboard, as given in 3-5-1/Table 1, is to be reasonably divided between the two bower anchors. Where three anchors are given in 3-5-1/Table 1, the third anchor is intended as a spare bower anchor and is listed for guidance only. It is not required as a condition of classification.							
Equipment Numeral	Equipment Number*	Stockless Bower Anchors		Chain Cable Stud Link Bower Chain			
		Number	Mass per Anchor, pounds	Length, fathoms	Diameter		
					Normal-Strength Steel (Grade 1), inches	High-Strength Steel (Grade 2), inches	Extra High-Strength Steel (Grade 3), inches
UA1	30	2	165	105	1/2	—	—
UA2	40	2	220	105	1/2	—	—
UA3	50	2	265	105	1/2	—	—
UA4	60	2	310	105	1/2	—	—
UA5	70	2	350	120	9/16	1/2	—
UA6	80	2	400	120	9/16	1/2	—
UA7	90	2	460	120	5/8	9/16	—
UA8	100	2	530	120	5/8	9/16	—
UA9	110	2	595	135	11/16	5/8	—
UA10	120	2	670	135	11/16	5/8	—
UA11	130	2	750	150	3/4	11/16	—
UA12	140	2	860	150	13/16	11/16	—
U6	150	2	1060	150	7/8	3/4	—
U7	175	2	1255	165	15/16	13/16	—
U8	205	3	1455	165	1	7/8	13/16
U9	240	3	1720	180	1 1/8	15/16	7/8
U10	280	3	1985	195	1 3/16	1	15/16
U11	320	3	2250	195	1 1/4	1 1/8	15/16
U12	360	3	2510	210	1 5/16	1 3/16	1
U13	400	3	2840	210	1 7/16	1 1/4	1 1/8
U14	450	3	3170	225	1 1/2	1 5/16	1 3/16
U15	500	3	3500	225	1 9/16	1 5/16	1 3/16
U16	550	3	3830	240	1 5/8	1 7/16	1 1/4
U17	600	3	4230	240	1 3/4	1 1/2	1 5/16
U18	660	3	4630	240	1 13/16	1 9/16	1 7/16
U19	720	3	5020	255	1 7/8	1 5/8	1 7/16
U20	780	3	5420	255	2	1 3/4	1 1/2
U21	840	3	5820	255	2 1/16	1 13/16	1 9/16
U22	910	3	6280	270	2 1/8	1 7/8	1 5/8
U23	980	3	6740	270	2 3/16	1 15/16	1 3/4
U24	1060	3	7270	270	2 5/16	2	1 13/16
U25	1140	3	7800	285	2 3/8	2 1/16	1 13/16
U26	1220	3	8330	285	2 7/16	2 1/8	1 7/8
U27	1300	3	8930	285	2 1/2	2 3/16	2
U28	1390	3	9520	300	2 5/8	2 5/16	2
U29	1480	3	10120	300	2 11/16	2 3/8	2 1/16
U30	1570	3	10800	300	2 3/4	2 7/16	2 1/8

TABLE 1 (continued)
Equipment for Self-propelled Ocean-going Craft

US Units							
Equipment Numeral	Equipment Number*	Stockless Bower Anchors		Length, fathoms	Chain Cable Stud Link Bower Chain		
		Number	Mass per Anchor, pounds		Diameter		
					Normal-Strength Steel (Grade 1), inches	High-Strength Steel (Grade 2), inches	Extra High-Strength Steel (Grade 3), inches
U31	1670	3	11600	315	2 7/8	2 1/2	2 3/16
U32	1790	3	12400	315	3	2 5/8	2 5/16
U33	1930	3	13200	315	3 1/16	2 11/16	2 3/8
U34	2080	3	14200	330	3 3/16	2 3/4	2 7/16
U35	2230	3	15200	330	3 5/16	2 7/8	2 1/2
U36	2380	3	16200	330	3 7/16	3	2 5/8
U37	2530	3	17200	345	3 9/16	3 1/16	2 11/16
U38	2700	3	18300	345	3 5/8	3 3/16	2 3/4
U39	2870	3	19200	345	3 3/4	3 5/16	2 7/8
U40	3040	3	20500	360	3 7/8	3 5/16	3
U41	3210	3	21800	360	3 15/16	3 7/16	3 1/16
U42	3400	3	23100	360	4	3 9/16	3 1/16
U43	3600	3	24500	375	4 1/8	3 5/8	3 3/16
U44	3800	3	25800	375	4 1/4	3 3/4	3 5/16
U45	4000	3	27100	375	4 3/8	3 7/8	3 7/16
U46	4200	3	28400	390	4 1/2	3 15/16	3 7/16
U47	4400	3	29800	390	4 5/8	4	3 9/16
U48	4600	3	31100	390	4 3/4	4 1/8	3 5/8
U49	4800	3	32400	405	4 3/4	4 1/4	3 3/4
U50	5000	3	33900	405	4 7/8	4 3/8	3 7/8
U51	5200	3	35500	405	5	4 3/8	3 7/8
U52	5500	3	37200	405	5 1/8	4 1/2	3 15/16
U53	5800	3	39200	405	5 1/8	4 5/8	4
U54	6100	3	41400	405	—	4 3/4	4 1/4
U55	6500	3	44000	420	—	4 7/8	4 3/8
U56	6900	3	47400	420	—	5	4 1/2
U57	7400	3	50700	420	—	5 1/8	4 5/8
U58	7900	3	54000	420	—	5 3/8	4 3/4
U59	8400	3	57300	420	—	5 5/8	5
U60	8900	3	60600	420	—	5 3/4	5 1/8
U61	9400	3	63900	420	—	6	5 1/8
U62	10000	3	68000	420	—	—	5 3/8
U63	10700	3	72500	420	—	—	5 5/8
U64	11500	3	78000	420	—	—	5 3/4
U65	12400	3	85000	420	—	—	6
U66	13400	3	92500	420	—	—	6 1/8
U67	14600	3	101500	420	—	—	6 3/8

* For intermediate values of equipment number use equipment complement in sizes and weights given for the lower equipment number in the table.

TABLE 2
Towline and Hawsers for Self-propelled Ocean-going Vessels

For intermediate values of equipment number, use equipment complement in sizes and weights given for the lower equipment number in the table.

SI & MKS Units

Equipment Numeral	Equipment Number*	Towline Wire or Rope			Hawsers			
		Length, m	Breaking Strength,		Number	Length of Each, m	Breaking Strength,	
			KN	kgf			kN	kgf
U6	150	180	98.0	10000	3	120	54.0	5500
U7	175	180	112.0	11400	3	120	59.0	6000
U8	205	180	129.0	13200	4	120	64.0	6500
U9	240	180	150.0	15300	4	120	69.0	7000
U10	280	180	174.0	17700	4	140	74.0	7500
U11	320	180	207.0	21100	4	140	78.0	8000
U12	360	180	224.0	22800	4	140	88.0	9000
U13	400	180	250.0	25500	4	140	98.0	10000
U14	450	180	277.0	28200	4	140	108.0	11000
U15	500	190	306.0	31200	4	160	123.0	12500
U16	550	190	338.0	34500	4	160	132.0	13500
U17	600	190	370.0	37800	4	160	147.0	15000
U18	660	190	406.0	41400	4	160	157.0	16000
U19	720	190	441.0	45000	4	170	172.0	17500
U20	780	190	479.0	48900	4	170	186.0	19000
U21	840	190	518.0	52800	4	170	201.0	20500
U22	910	190	559.0	57000	4	170	216.0	22000
U23	980	200	603.0	61500	4	180	230.0	23500
U24	1060	200	647.0	66000	4	180	250.0	25500
U25	1140	200	691.0	70500	4	180	270.0	27500
U26	1220	200	738.0	75300	4	180	284.0	29000
U27	1300	200	786.0	80100	4	180	309.0	31500
U28	1390	200	836.0	85200	4	180	324.0	33000
U29	1480	220	888.0	90600	5	190	324.0	33000
U30	1570	220	941.0	96000	5	190	333.0	34000
U31	1670	220	1024.0	104400	5	190	353.0	36000
U32	1790	220	1109.0	113100	5	190	378.0	38500
U33	1930	220	1168.0	119100	5	190	402.0	41000
U34	2080	240	1259.0	128400	5	200	422.0	43000
U35	2230	240	1356.0	138300	5	200	451.0	46000
U36	2380	240	1453.0	148200	5	200	480.0	49000
U37	2530	260	1471.0	150000	6	200	480.0	49000
U38	2700	260	1471.0	150000	6	200	490.0	50000
U39	2870	260	1471.0	150000	6	200	500.0	51000
U40	3040	280	1471.0	150000	6	200	520.0	53000
U41	3210	280	1471.0	150000	6	200	554.0	56500
U42	3400	280	1471.0	150000	6	200	588.0	60000
U43	3600	300	1471.0	150000	6	200	618.0	63000
U44	3800	300	1471.0	150000	6	200	647.0	66000
U45	4000	300	1471.0	150000	7	200	647.0	66000

TABLE 2 (continued)
Towline and Hawsers for Self-propelled Ocean-going Vessels

SI & MKS Units

Equipment Numeral	Equipment Number*	Towline Wire or Rope			Hawsers			
		Length, m	Breaking Strength,		Number	Length of Each, m	Breaking Strength,	
			KN	kgf			kN	kgf
U46	4200	300	1471.0	150000	7	200	657.0	67000
U47	4400	300	1471.0	150000	7	200	667.0	68000
U48	4600	300	1471.0	150000	7	200	677.0	69000
U49	4800	300	1471.0	150000	7	200	686.0	70000
U50	5000	300	1471.0	150000	8	200	686.0	70000
U51	5200	300	1471.0	150000	8	200	696.0	71000
U52	5500	300	1471.0	150000	8	200	706.0	72000
U53	5800	300	1471.0	150000	9	200	706.0	72000
U54	6100	300	1471.0	150000	9	200	716.0	73000
U55	6500	300	1471.0	150000	9	200	726.0	74000
U56	6900	300	1471.0	150000	10	200	726.0	74000
U57	7400	300	1471.0	150000	11	200	726.0	74000
U58	7900	—	—	—	12	200	736.0	75000
U59	8400	—	—	—	12	200	736.0	75000
U60	8900	—	—	—	13	200	736.0	75000
U61	9400	—	—	—	14	200	736.0	75000
U62	10000	—	—	—	15	200	736.0	75000
U63	10700	—	—	—	16	200	736.0	75000
U64	11500	—	—	—	17	200	736.0	75000
U65	12400	—	—	—	18	200	736.0	75000
U66	13400	—	—	—	19	200	736.0	75000
U67	14600	—	—	—	21	200	736.0	75000

TABLE 2
Towline and Hawsers for Self-propelled Ocean-going Vessels

For intermediate values of equipment number, use equipment complement in sizes and weights given for the lower equipment number in the table.

US Units

Equipment Numeral	Equipment Number*	Towline Wire or Rope		Hawsers		
		Length, Fathoms	Breaking Strength, Pounds	Number	Length of Each Fathoms	Breaking Strength, Pounds
U6	150	98	22000	3	66	12100
U7	175	98	25100	3	66	13200
U8	205	98	29100	4	66	14300
U9	240	98	33700	4	66	15400
U10	280	98	39000	4	77	16500
U11	320	98	46500	4	77	17600
U12	360	98	50300	4	77	19800
U13	400	98	56200	4	77	22000
U14	450	98	62200	4	77	24200
U15	500	104	68800	4	88	27600
U16	550	104	76000	4	88	29800
U17	600	104	83300	4	88	33100
U18	660	104	91200	4	88	35300
U19	720	104	99200	4	93	38600
U20	780	104	107800	4	93	41900
U21	840	104	116400	4	93	45200
U22	910	104	125600	4	93	48500
U23	980	109	135500	4	98	51800
U24	1060	109	145500	4	98	56200
U25	1140	109	155400	4	98	60600
U26	1220	109	166000	4	98	63900
U27	1300	109	176500	4	98	69400
U28	1390	109	187800	4	98	72800
U29	1480	120	199700	5	104	72800
U30	1570	120	211500	5	104	75000
U31	1670	120	230000	5	104	79400
U32	1790	120	249500	5	104	84900
U33	1930	120	262500	5	104	90400
U34	2080	131	283000	5	109	94800
U35	2230	131	305000	5	109	101400
U36	2380	131	326500	5	109	108000
U37	2530	142	330500	6	109	108000
U38	2700	142	330500	6	109	110200
U39	2870	142	330500	6	109	112400
U40	3040	153	330500	6	109	116800
U41	3210	153	330500	6	109	124600
U42	3400	153	330500	6	109	132300
U43	3600	164	330500	6	109	138900
U44	3800	164	330500	6	109	145500
U45	4000	164	330500	7	109	145500

TABLE 2 (continued)
Towline and Hawsers for Self-propelled Ocean-going Vessels

US Units

Equipment Numeral	Equipment Number*	Towline Wire or Rope		Hawsers		
		Length, Fathoms	Breaking Strength, Pounds	Number	Length of Each, Fathoms	Breaking Strength, Pounds
U46	4200	164	330500	7	109	147700
U47	4400	164	330500	7	109	149900
U48	4600	164	330500	7	109	152100
U49	4800	164	330500	7	109	154300
U50	5000	164	330500	8	109	154300
U51	5200	164	330500	8	109	156500
U52	5500	164	330500	8	109	158700
U53	5800	164	330500	9	109	158700
U54	6100	164	330500	9	109	160900
U55	6500	164	330500	9	109	163100
U56	6900	164	330500	10	109	163100
U57	7400	164	330500	11	109	163100
U58	7900	—	—	11	109	165300
U59	8400	—	—	12	109	165300
U60	8900	—	—	13	109	165300
U61	9400	—	—	14	109	165300
U62	10000	—	—	15	109	165300
U63	10700	—	—	16	109	165300
U64	11500	—	—	17	109	165300
U65	12400	—	—	18	109	165300
U66	13400	—	—	19	109	165300
U67	14600	—	—	21	109	165300

PART

3

CHAPTER **5 Equipment**

APPENDIX **1 Alternative Standard for the Required Anchor Size**

1 General

All craft are to have anchor and chain that comply with the requirements in Section 3-5-1 of this Guide or the requirements listed below. The letter **ⓔ** will signify that the equipment of the craft is in compliance with the requirements in the Guide and tested in accordance with Section 3-5-1/9 of this Guide.

3 Anchor Size Requirement

A minimum of one (1) anchor is to be provided that has a holding power in a bottom that has an average consistency between mud and sand that is greater than determined by the following equation. The holding power of the anchor is to be certified by the anchor manufacturer.

$$HP = 0.0195AV_w^2 + 0.114\sqrt{\Delta L} (V_c)^{1.825} + 7.74N_pA_pV_c^2 \quad \text{kg}$$

$$HP = 0.004AV_w^2 + 0.14\sqrt{\Delta L} (V_c)^{1.825} + 1.59N_pA_pV_c^2 \quad \text{lbf}$$

where

- HP = required holding power of anchor, in kg (lbf)
- A = projected frontal area of the craft above the waterline, in m² (ft²)
- V_w = velocity of wind acting on the craft, not to be taken less than 50 knots
- Δ = molded displacement of the craft, in mt (lbf), to the summer load line
- L = length of craft, in m (ft), as defined in 3-1-1/3
- V_c = velocity of current acting on the craft, not to be taken less than 3 knots
- N_p = number of propellers fitted on the craft
- A_p = area of one propeller, in m² (ft²)

5 Anchor Chain, Cable, or Rope

The required size and length of chain, cable, or rope is to be as indicated in 3-5-1. Where one anchor is allowed the required chain length is one half the length required from 3-5-1/Table 1.

PART
3

CHAPTER **6** **Navigation**

CONTENTS

SECTION 1	Visibility.....	232
1	Navigation Bridge Visibility.....	232
1.1	Field of Vision.....	232
1.3	Windows and Their Arrangements	234
1.5	Unconventional Design.....	235
	FIGURE 1.....	232
	FIGURE 2.....	233
	FIGURE 3.....	234
	FIGURE 4.....	234
	FIGURE 5.....	234
	FIGURE 6.....	234

CHAPTER 6 Navigation

SECTION 1 Visibility

1 Navigation Bridge Visibility

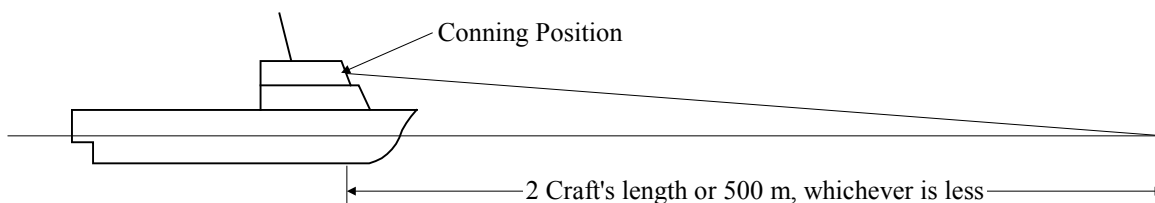
All craft of not less than 55 m (180 ft) in length overall having the keel laid or in similar stage of construction on or after 1 July 1998 are to meet the following requirements with regard to the visibility from the navigation bridge, unless they are navigating solely the Great Lakes of North America and their connecting and tributary waters as far east as the lower exit of the St. Lambert Lock at Montreal in the Province of Quebec, Canada. Special consideration will be given to craft that operate only on domestic or on short, limited, international voyages.

1.1 Field of Vision

1.1.1 Conning Position

1.1.1(a) The view of the sea surface from the conning position is not to be obscured by more than $2L_{OA}$ (Length Overall) or 500 m (1640 ft), whichever is less, forward of the bow to 10° on either side for all conditions of draft, trim and deck cargo under which the particular craft is expected to operate. See 3-6-1/Figure 1.

FIGURE 1



- 1 A conning position is a place on the bridge with a commanding view and which is used by navigators when commanding, maneuvering and controlling a craft.
- 2 Attention is drawn to flag Administrations requiring lengths of less than $2L_{OA}$.

1.1.1(b) No blind sector caused by cargo, cargo gear or other obstructions outside of the wheelhouse forward of the beam which obstructs the view of the sea surface as seen from the conning position is to exceed 10° . The total arc of blind sectors is not to exceed 20° . The clear sectors between blind sectors are to be at least 5° . However, in the view described in 3-6-1/1.1.1(a), each individual blind sector is not to exceed 5° .

1.1.1(c) The horizontal field of vision from the conning position is to extend over an arc of not less than 225° , that is, from right ahead to not less than 22.5° abaft the beam on either side of the craft. See 3-6-1/Figure 3.

1.1.2 Bridge Wing

1.1.2(a) From each bridge wing, the horizontal field of vision is to extend over an arc of at least 225°, that is, from at least 45° on the opposite bow to right ahead and then from right ahead to right astern through 180° on the same side of the craft. See 3-6-1/Figure 4.

1.1.2(b) The craft's side is to be visible from the bridge wing.

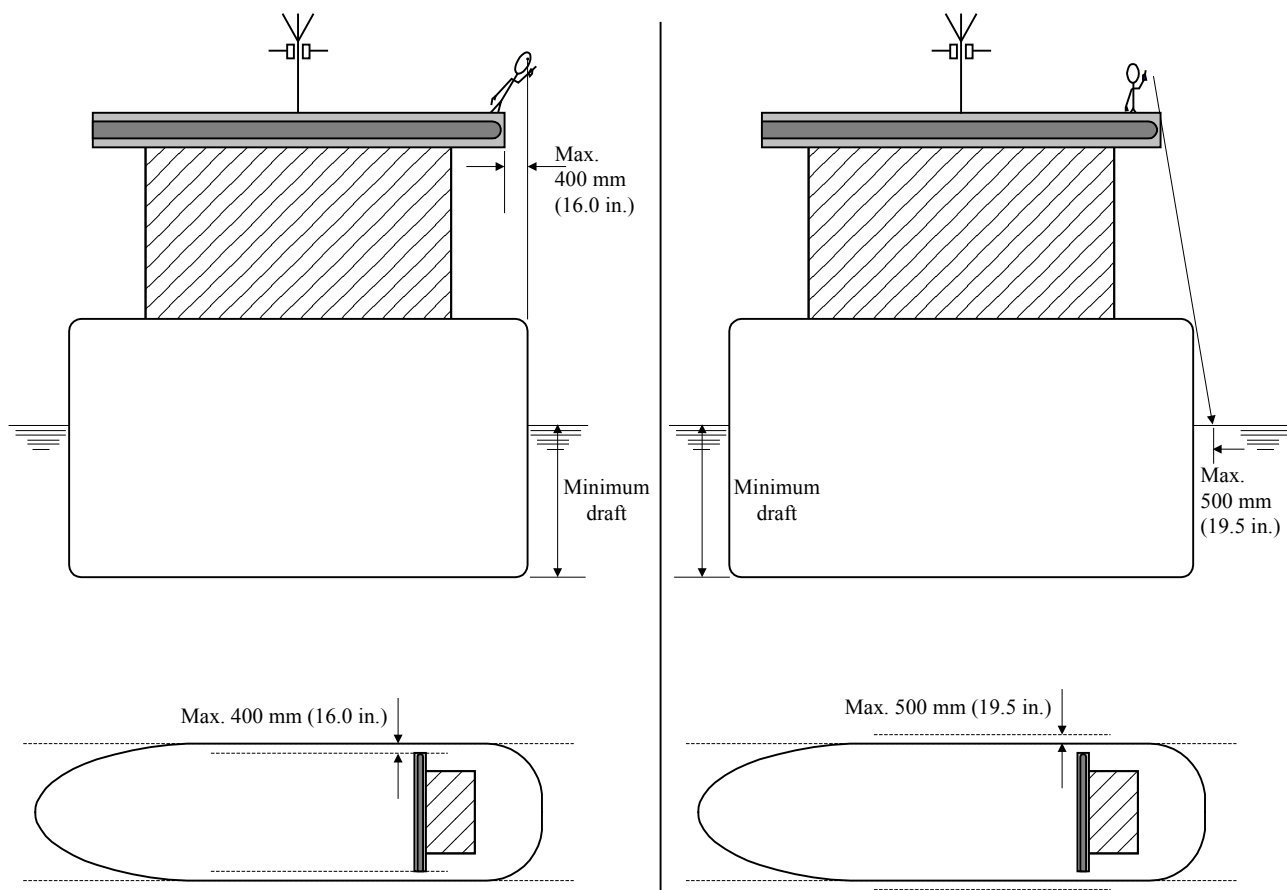
i) The requirements of 3-6-1/1.1.2(b) are accomplished when:

- A view from the bridge wing plus a distance corresponding to a reasonable and safe distance of a seafarer leaning over the side of the bridge wing, which needs not to be more than 400 mm (16 in.), to the location vertically right under the maximum beam of the ship at the lowest seagoing draft is not obscured; or
- The sea surface at the lowest seagoing draft and with a transverse distance of 500 mm (19.5 in.) and more from the maximum beam throughout the ship's length is visible from the side of the bridge wing.

See 3-6-1/Figure 2.

ii) For particular ship types, such as tug/tow boat, offshore supply vessel (OSV), rescue ship, work ship (e.g., floating crane ships), etc., that are designed such that, in normal operations, they come along side, or operate in close proximity to, other vessels or offshore structures at sea, 3-6-1/1.1.2(b) is met provided the bridge wings extend at least to a location from which the sea surface, at the lowest seagoing draft and at a transverse distance of 1500 mm (59 in.) from the maximum beam throughout the ship's length, is visible. If this ship type is changed to a type other than those addressed in this paragraph, then the interpretation in this paragraph would no longer apply.

FIGURE 2



1.1.3 Main Steering Position

From the main steering position, the horizontal field of vision is to extend over an arc from right ahead to at least 60° on each side of the craft. See 3-6-1/Figure 5.

FIGURE 3

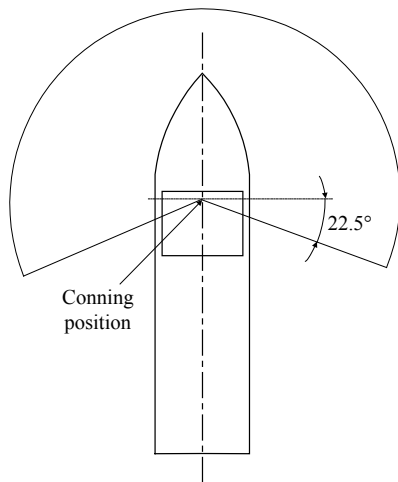


FIGURE 4

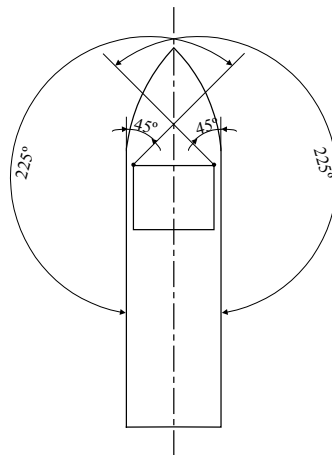
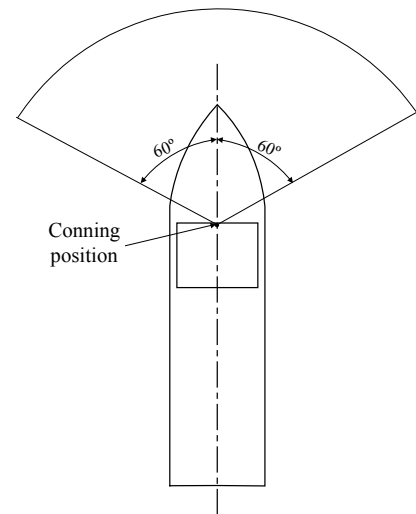


FIGURE 5



1.3 Windows and Their Arrangements

Windows and their arrangements are to meet the following requirements:

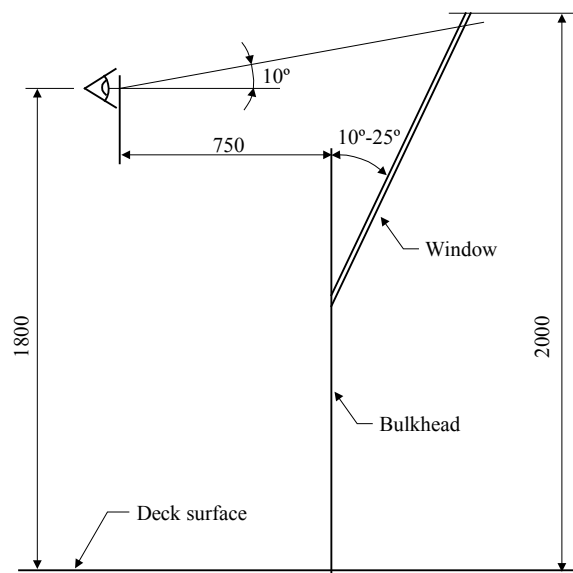
1.3.1 Framing

Framing between navigation bridge windows is to be kept to a minimum to meet the structural strength and stiffness requirements, and is not to be installed immediately in front of any workstations.

1.3.2 Inclination Angle

The bridge front windows are to be inclined from a vertical plane top out, at an angle of not less than 10° and not more than 25°, see 3-6-1/Figure 6.

FIGURE 6



1.3.3 Glass

Polarized and tinted windows are not to be fitted.

1.3.4 Clear View

At all times, regardless of the weather conditions, at least two of the navigation bridge front windows are to provide a clear view, and in addition, depending on the bridge configuration, an additional number of windows are to provide a clear view. To this end, the following, or equivalent, is to be provided:

1.3.4(a) Sun Screens. Sunscreens with minimum color distortion. These sunscreens are to be readily removable and not permanently installed.

1.3.4(b) Wipers and Fresh Water Wash Systems. Heavy-duty wipers, preferably provided with an interval function, and fresh water wash systems. These wipers are to be capable of operating independently of each other.

1.3.4(c) De-icing and De-misting Systems. De-icing and de-misting systems to be provided.

1.3.4(d) Fixed Catwalk. A fixed catwalk with guardrails, fitted forward of the bridge windows, to enable manual cleaning of windows in the event of failure of the above systems.

1.3.5 Lower Edge

The height of the lower edge of the navigation bridge front windows above the bridge deck is to be kept as low as possible. In no case is the lower edge to present an obstruction to the forward view as described in this Section.

1.3.6 Upper Edge

The upper edge of the navigation bridge front windows is to allow a forward view of the horizon for a person with a height of eye of 1800 mm (5 ft-11 in.) above the bridge deck at the conning position when the craft is pitching in heavy seas. ABS, if satisfied that an 1800 mm (5 ft-11 in.) height of eye is unreasonable and impractical, may allow reduction of the height of eye, but not to less than 1600 mm (5 ft-3 in.). See 3-6-1/Figure 5.

1.5 Unconventional Design

For craft of unconventional design which cannot comply with the above requirements, arrangements are to be provided to the satisfaction of ABS to achieve a level of visibility that is as near as practical to those prescribed in this Section.

PART
3

CHAPTER **7 Testing, Trials and Surveys During Construction – Hull**

CONTENTS

SECTION 1	Tank, Bulkhead and Rudder Tightness Testing.....	237
1	General	237
1.1	Application	237
1.3	Definitions.....	237
3	Test Procedures.....	238
3.1	General.....	238
3.3	Structural Testing.....	238
3.5	Air Testing	238
3.7	Hose Testing	238
5	Details of Testing	238
5.1	Hydrostatic Testing	238
5.3	Hydropneumatic Testing.....	238
5.5	Air Testing	238
5.7	Hose Testing	239
5.9	Other Methods of Testing	239
7	Application of Coating	239
7.1	Final Coating	239
7.3	Temporary Coating.....	239
	TABLE 1 Testing Requirements for Tanks and Boundaries	240
SECTION 2	Trials	242
1	Anchor Windlass Trials	242
3	Bilge System Trials	242
5	Steering Trials.....	242
SECTION 3	Surveys.....	243
1	Construction Welding and Fabrication.....	243
3	Hull Castings and Forgings.....	243
5	Piping	243

PART

3

CHAPTER 7 Testing, Trials and Surveys During Construction – Hull

SECTION 1 Tank, Bulkhead and Rudder Tightness Testing

1 General

1.1 Application

All gravity tanks, excluding independent tanks of less than 5 m³ (176 ft³) in capacity, and other boundaries required to be watertight or weathertight are to be tested in accordance with this subsection and proven tight or structurally adequate as follows:

1.1.1

Gravity Tanks for their structural adequacy and tightness,

1.1.2

Watertight Boundaries Other Than Tank Boundaries for their watertightness, and

1.1.3

Weathertight Boundaries for their weathertightness.

1.3 Definitions

1.3.1

Structural Testing is a test to verify the structural adequacy of the design and the tightness of the tanks.

1.3.2

Air Testing is a test to verify the tightness of the structure by means of air pressure difference.

1.3.3

Hose Testing is a test to verify the tightness of the structure by a jet of water.

1.3.4

Hydropneumatic Testing is a combined hydrostatic and air testing wherein a tank is filled by water with air pressure applied on top.

1.3.5

Hydrostatic Testing is a test to verify the structural adequacy of the design and the tightness of the tank's structure by means of water pressure, by filling water to the level as specified in 3-7-1/Table 1. Hydrostatic testing is the normal means for structural testing with exception as per 3-7-1/3.3.

3 Test Procedures

3.1 General

Tests are to be carried out in the presence of the Surveyor at a stage sufficiently close to completion, after all attachments, outfittings or penetrations which may affect the strength or tightness of the structure have been completed, and before any ceiling and cement work is applied over joints.

Specific test requirements are given in 3-7-1/5 and 3-7-1/Table 1.

For the timing of application of coating in relation to testing, see 3-7-1/7.

3.3 Structural Testing

Where structural testing is specified by 3-7-1/Table 1, hydrostatic testing in accordance with 3-7-1/5.1 will be acceptable, except where practical limitations prevent it or where air testing is permitted by Note 1 to 3-7-1/Table 1. Hydropneumatic testing, in accordance with 3-7-1/5.3, may be approved in lieu of hydrostatic testing. Structural testing may be carried out after the vessel is launched.

Tank boundaries are to be tested at least from one side. Tanks to be tested for structural adequacy (see Note 1 to 3-7-1/Table 1) are to be selected so that all representative structural members are tested for the expected tension and compression.

3.5 Air Testing

Air testing is to be in accordance with 3-7-1/5.5.

3.7 Hose Testing

Hose testing is applied to structures not subjected to structural or air testing but required to be watertight or weathertight as specified in 3-7-1/Table 1. For the details of hose testing, see 3-7-1/5.7. Air testing or structural testing may be accepted in lieu of hose testing.

5 Details of Testing

5.1 Hydrostatic Testing

Hydrostatic testing is to consist of a head of water to the level specified in 3-7-1/Table 1.

5.3 Hydropneumatic Testing

When approved, the combined water level and air pressure used for hydropneumatic testing is to simulate the actual loading as far as practicable. The requirements and recommendations in 3-7-1/5.5 relative to air pressure will also apply.

5.5 Air Testing

All boundary welds, erection joints, and penetrations including pipe connections are to be examined in accordance with the approved procedure and under a pressure differential not less than 0.15 bar (0.15 kgf/cm², 2.2 psi) with a leak indicating solution.

It is recommended that the air pressure in the tank be raised to and maintained at 0.20 bar (0.20 kgf/cm², 2.9 psi) for approximately one hour, with a minimum number of personnel around the tank, before being lowered to the test pressure.

A U-tube with a height sufficient to hold a head of water corresponding to the required test pressure is to be arranged. The cross sectional area of the U-tube is to be not less than that of the pipe supplying air. In addition to the U-tube, a master gauge or other approved means is to be provided to verify the pressure.

Other effective methods of air testing, including compressed air fillet weld testing or vacuum testing, may be considered in accordance with 3-7-1/5.9.

5.7 Hose Testing

Hose testing is to be carried out with the pressure in the hose of at least 2 bar (2 kgf/cm², 30 psi) during test. The nozzle is to have minimum inside diameter of 12 mm (0.5 in.) and is to be located at a distance to the joint not exceeding 1.5 m (5 ft).

5.9 Other Methods of Testing

Other methods of testing may be considered upon submission of full particulars.

7 Application of Coating

7.1 Final Coating

7.1.1 Structural Testing

Final coating may be applied prior to the hydrostatic testing, provided an air test is carried out before the application of the final coating.

7.1.2 Air Testing

For all manual or semi-automatic erection welds and all fillet weld tank boundary connections including penetrations, the final coating is to be applied after air testing. For other welds, the final coating may be applied prior to air testing, provided the Surveyor, after examination prior to the application of the coating, is satisfied with the weld. The Surveyor reserves the right to require air testing prior to the final coating of automatic erection welds and manual or automatic pre-erection welds.

7.1.3 Hose Testing

The final coating is to be applied after all required hose testing is completed.

7.3 Temporary Coating

Any temporary coating which may conceal defects or leaks is to be applied as specified for the final coating. This requirement applies to shop primers, other than silicate based shop primers, such as epoxy based shop primers.

TABLE 1
Testing Requirements for Tanks and Boundaries

	<i>Structures to be Tested</i>	<i>Type of Testing</i>	<i>Hydrostatic Testing Head or Pressure</i>	<i>Remarks</i>
1	Double Bottom Tanks	Structural ^(1,2)	The greater of - to the top of overflow, or - to the bulkhead deck	
2	Double Side Tanks	Structural ^(1,2)	The greater of - to the top of overflow, or - to 2.4 m (8 ft) above top of tank ⁽³⁾	
3	Deep Tanks or Cargo Oil Tanks	Structural ^(1,2)	The greatest of - to the top of overflow, - to 2.4 m (8 ft) above top of tank ⁽³⁾ , or - to the top of tank ⁽³⁾ plus setting of any pressure relief valve	
	Fuel Oil Bunkers	Structural		
4a	Peak Tanks	Structural	The greater of - to the top of overflow, or - to 2.4 m (8 ft) above top of tank ⁽³⁾	After peak tank test to be carried out after installation of stern tube.
4b	Fore Peak Voids (collision bhd.)	See Note 4	See Note 4	
4c	Aft Peak Voids	Air		
5	Cofferdams	Structural ⁽⁵⁾	The greater of - to the top of overflow, or - to 2.4 m (8 ft) above top of cofferdam	
6	Watertight Bulkheads	Hose ⁽⁶⁾		
7	Watertight Doors below freeboard or bulkhead deck	Hose		See Note 8 for additional test at the manufacturer.
8	Double Plate Rudder	Air		
9	Shaft Tunnel Clear of Deep Tanks	Hose		
10	Shell Doors	Hose		
11	Weather-tight Hatch Covers, Doors and other Closing Appliances	Hose ⁽⁶⁾		
12a	Chain Locker and Chain Pipe (aft of collision bulkhead)	Structural	To the top of chain pipe	
12b	Chain Locker and Chain Pipe (fwd of collision bulkhead)	Structural ⁽⁷⁾	To the top of chain pipe	
13	Independent Tanks	Structural	The greater of - to the top of overflow, or - to 0.9 m (3 ft) above top of tank	
14	Ballast Ducts	Structural	Ballast pump maximum pressure or setting of any relief valve for the ballast duct if that is less.	
15	Hawse Pipes	Hose		

TABLE 1 (continued)
Testing Requirements for Tanks and Boundaries

Notes:

- 1 Provided the structural similarity of a group of tanks is recognized by ABS and a representative tank as selected by ABS is structurally tested based on the design approval, air testing in accordance with 3-7-1/5.5 may be accepted. In general, structural testing need not be repeated for subsequent vessels of a series of identical newbuildings. Subsequent tanks may require hydrostatic testing, if found necessary, after the structural testing.
- 2 All cargo segregation boundaries in oil carriers and combination carriers and tanks for segregated cargoes of pollutants are to be hydrostatically tested.
- 3 Top of tank is the deck forming the top of the tank, excluding hatchways. In holds for liquid cargo or ballast with large hatch covers, the top of tank is to be taken at the top of the hatch coaming.
- 4 Hydrostatic testing to the damaged waterline but not less than the distance to the bulkhead deck.
- 5 Air testing in accordance with 3-7-1/5.5 may be accepted, except that hydropneumatic testing may be required in consideration of the construction techniques and welding procedures employed.
- 6 Where hose testing is impractical due to the stage of outfitting, air test or other alternate method of testing such as close visual examination and, where necessary, nondestructive test of all joints may be considered.
- 7 In general, structural testing need not be repeated for subsequent craft of a series of identical newbuildings provided air testing in accordance with 3-7-1/5.5 is carried out. Subsequent chain lockers may require hydrostatic testing if found necessary after the structural testing.
- 8 Sliding doors are to be tested for operation at the manufacturer's plant. Hydrostatic testing of sliding doors is also to be carried out at the manufacturer's plant, with a head of water equivalent to the height to the bulkhead deck or freeboard deck at center.

PART

3

CHAPTER **7 Testing, Trials and Surveys During Construction – Hull**

SECTION **2 Trials**

1 Anchor Windlass Trials

Each windlass is to be tested under working conditions after installation onboard to demonstrate satisfactory operation. Each unit is to be independently tested for braking, clutch functioning, lowering and hoisting of chain cable and anchor, proper riding of the chain over the chain lifter, proper transit of the chain through the hawse pipe and the chain pipe, and effecting proper stowage of the chain and the anchor. It is to be confirmed that anchors properly seat in the stored position and that chain stoppers function as designed if fitted. Also, it is to be demonstrated that the windlass is capable of lifting each anchor with 82.5 meters (45 fathoms) length of chain submerged and hanging free. The braking capacity is to be tested by intermittently paying out and holding the chain cable by means of the application of the brake. Where the available water depth is insufficient, the proposed test method will be specially considered.

3 Bilge System Trials

All elements of the bilge system are to be tested to demonstrate satisfactory pumping operation, including emergency suction and all controls. Upon completion of the trials, the bilge strainers are to be opened, cleaned and closed up in good order.

5 Steering Trials

Refer to 4-3-3/15 for the technical details of the steering trials.

PART

3

CHAPTER **7** **Testing, Trials and Surveys During Construction – Hull**

SECTION **3** **Surveys**

1 **Construction Welding and Fabrication**

For surveys of hull construction welding and fabrication, refer to Chapter 4 of the *Rules for Materials and Welding (Part 2)* and Appendix 2-5-A1 of the *Rules for Materials and Welding (Part 2) – Aluminum and Fiber Reinforced Plastics (FRP)* and to the *ABS Guide for Nondestructive Inspection of Hull Welds*.

3 **Hull Castings and Forgings**

For surveys in connection with the manufacture and testing of hull castings and forgings, refer to Chapter 1 of the *Rules for Materials and Welding (Part 2)*.

5 **Piping**

For surveys in connection with the manufacture and testing of piping, refer to Part 4, Chapter 4 of this Guide.