



GUIDE FOR

PORTABLE ACCOMMODATION MODULES

JANUARY 2013 (Updated June 2018 – see next page)

**American Bureau of Shipping
Incorporated by Act of Legislature of
the State of New York 1862**

**© 2013-2018 American Bureau of Shipping. All rights reserved.
ABS Plaza
16855 Northchase Drive
Houston, TX 77060 USA**

Updates

July 2016 consolidation includes:

- May 2014 version plus Notice No. 2

May 2014 consolidation includes:

- February 2013 version plus Notice No. 1 and Corrigenda/Editorials

February 2013 consolidation includes:

- January 2013 version plus Corrigenda/Editorials

Foreword (1 July 2016)

This *Guide for Portable Accommodation Modules* has been developed to provide a consolidated set of requirements for portable accommodation modules that may be installed onboard a variety of vessels or offshore installations.

This Guide outlines the ABS requirements for the design and survey of accommodation modules installed onboard ABS-classed Mobile Offshore Drilling Units (MODUs), and Mobile Offshore Units (MOUs), Offshore Installations (fixed or floating), Steel Barges, and Steel Vessels. The Guide may be voluntarily applied to other type of portable modules.

The requirements contained in this Guide are for design, construction, installation, and survey of accommodation modules and are based on the applicable ABS Rules and Guides, for the vessel type. No part of an accommodation module is to be designed and built to a lesser standard than a deckhouse on the same facility unless explicitly indicated in this Guide.

In this latest revision, new requirements and procedures are introduced to meet service challenge and reflect the best industry practices. These updates are summarized in the following table:

<i>Section</i>	<i>Summary of Change</i>
2/9.1 Fire Integrity of Exterior Boundaries	Made integrity of exterior boundaries align with the MODU Code.
2/9.3 Fire Integrity of Interior Boundaries	Made integrity of Interior boundaries align with the MODU Code
2/9.7 Penetrations of Cables	Aligned requirements for cable penetrations with SOLAS, 2009 MODU Code and ABS MODU Rules
2/9.9 Penetration of Piping	Aligned requirements for cable penetrations with SOLAS, 2009 MODU Code and ABS MODU Rules.
2/23.3 Side and End Bulkhead Plating	Included the minimum thickness requirements for aluminum plating.
2/23.7.1 Corrugated Bulkhead Plating	Included the minimum thickness requirements for aluminum plating.
2/23.11.1 Bottom Deck Plating	Included the minimum thickness requirements for aluminum plating.
2/23.19 Racking Resistance	Clarified that racking resistance is required only for modules with bulkheads constructed with a plating thickness of less than 5 mm.
3/5 Survey Requirements	Aligned with ABS Steel Vessel Rules and MODU Rules, all cable penetrations are to be properly arranged to maintain the fire rated division integrity.

This Guide becomes effective on the first day of the month of publication.

Users are advised to check periodically on the ABS website www.eagle.org to verify that this version of this Guide is the most current.

We welcome your feedback. Comments or suggestions can be sent electronically by email to rsd@eagle.org.



GUIDE FOR PORTABLE ACCOMMODATION MODULES

CONTENTS

SECTION 1	Introduction	1
1	Purpose.....	1
3	Background.....	1
5	Application.....	1
7	Class Approval Process.....	2
9	Definitions	2
	 FIGURE 1 Illustration of Protected and Unprotected Front Bulkheads	 3
SECTION 2	Design Review of Module	4
1	General	4
3	Plans and Data to be Submitted	4
5	Structural Fire Protection Requirements.....	5
5.1	General.....	5
5.3	Administration Review	5
7	Materials of Construction	5
7.1	Primary Deck Coverings	5
7.3	Insulating Materials.....	5
7.5	Ceilings and Linings.....	5
7.7	Use of Combustible Materials	5
7.9	Maximum Calorific Value of Combustible Materials.....	6
7.11	Total Volume of Combustible Materials	6
7.13	Low Flame-spread Characteristics of Exposed Surfaces	6
7.15	Paints, Varnishes and Other Finishes.....	6
7.17	Materials Containing Asbestos	6
9	Fire Integrity	6
9.1	Fire Integrity of Exterior Boundaries	6
9.3	Fire Integrity of Interior Bulkheads.....	7
9.5	Fire Integrity of Decks.....	8
9.7	Penetrations of Cables	8
9.9	Penetration of Piping	9
11	Ventilation	9
11.1	General.....	9
11.3	Means for Closing.....	9
11.5	Power Ventilation.....	9
11.7	Penetrations of Vent Ducts	9

13	Special Requirements.....	10
13.1	Category A Machinery Space.....	10
13.3	MODUs.....	11
13.5	Offshore Production Installations.....	11
13.7	Oil Tankers.....	11
13.9	Ro-Ro and Vehicle Spaces.....	11
13.11	Galleys.....	11
15	Electrical Requirements.....	11
15.1	General.....	11
15.3	Principles for Electrical Protection.....	11
15.5	Public Address (PA).....	12
15.7	General Alarm (GA).....	12
15.9	Combined PA/GA.....	13
15.11	Emergency Lighting.....	13
15.13	Refrigerated Spaces – Locked-In Alarm.....	13
15.15	Fire Detection and Alarm System.....	13
15.17	Ventilation.....	13
15.19	Hazardous Areas.....	14
15.21	Document Packages.....	14
17	Piping Requirements.....	15
19	Fire Fighting Requirements.....	15
21	Machinery Requirements.....	15
23	Structural Requirements.....	15
23.1	General.....	15
23.3	Side and End Bulkhead Plating.....	16
23.5	Side and End Bulkhead Stiffeners.....	17
23.7	Corrugated Bulkheads.....	17
23.9	Roof Deck.....	19
23.11	Bottom Deck.....	19
23.13	Deck Girders and Transverses.....	21
23.15	Sidescuttles and Windows.....	21
23.17	Doors and Other Closing Appliances.....	23
23.19	Racking Resistance.....	23
23.21	Stacking of Modules.....	23
23.23	Materials of Construction.....	23
23.25	Aluminum Modules.....	24
25	Protection of Steel.....	25
27	ILO Convention.....	25
TABLE 1	Fire Integrity of Bulkheads Separating Adjacent Spaces.....	8
TABLE 2	Typical Design Head Values.....	16
TABLE 3	Minimum Bottom Deck Loading.....	20
TABLE 4	22
TABLE 5	23
TABLE 6	Minimum Mechanical Properties for Butt-Welded Aluminum Alloys.....	25

FIGURE 1	Ventilation Ducts Penetrating “A” Class Divisions	10
FIGURE 2	Corrugated Bulkhead	18
SECTION 3	Survey of Module at Fabrication Yard	26
1	General	26
3	Documentation	26
5	Survey Requirements	26
7	Marking	26
9	Type Approval	27
SECTION 4	Design Review for Installation Approval	28
1	General	28
3	Submission of Plans	28
5	Arrangement	29
7	Stability Requirements	29
9	Structures	29
9.1	General	29
9.3	Steel Vessels	29
9.5	Steel Cargo Vessels Under 90 Meters	29
9.7	Steel Barges	29
9.9	MODUs and MOUs	30
9.11	Floating Production Installations	30
9.13	High Speed Craft	30
11	Securing to the Deck	30
13	Stacking Arrangements	30
13.1	Loading	30
13.3	Structural Analysis	31
15	Electrical Requirements	32
15.1	Connection to Host Vessel	32
15.3	Communications	33
15.5	Combined PA/GA	33
15.7	External Egress Lighting	33
15.9	Refrigerated Spaces – Locked-In Alarm	33
15.11	Fire Detection and Alarm System	34
15.13	Ventilation	34
15.15	Hazardous Areas	34
15.17	Integration with Host Vessel's ESD system	34
17	Piping Requirements	34
19	Fire Fighting Requirements	34
23	Tonnage	35
25	ILO	35
27	Lifesaving Appliances	35
29	Structural Fire Protection	35
31	Means of Escape and Safe Passage	35

SECTION 5	Survey Onboard Host Vessel	36
1	General	36
3	Installation Survey Onboard	36
5	Annual Surveys for Modules in Service	36
7	Survey of Stacking Arrangements	36
APPENDIX 1	Sample Letter	37
APPENDIX 2	References	39

This Page Intentionally Left Blank



SECTION 1 Introduction

1 Purpose

This document provides ABS requirements for the design, construction, and survey of accommodation modules installed onboard ABS-classed vessels or offshore units. Flag Administration requirements should be considered in addition to this Guide.

3 Background

The installation of modular buildings for use as living quarters, industrial spaces, and workshops has become increasingly prevalent in recent years. Irrespective of the amount of time that portable modules are installed onboard, the potential risks to personnel within these buildings can be comparable to those within a traditional living quarters structure.

Due to the transient nature of portable accommodation modules, it is possible that the buildings may be installed on a number of different types of vessels and offshore units over their life. In recognizing that the ABS class requirements differ based on the type of host vessel or facility, this Guide has been created to outline the process for the design and survey of the modules and to establish the requirements for modules which can be used on any category of offshore drilling unit, production facility, barge, steel vessel, or high speed craft.

5 Application *(1 May 2014)*

This Guide is intended for accommodation modules installed onboard ABS-classed vessels or offshore units.

Industrial modules in which people normally work (laboratories, workshops, wireline units, mudloggers, ROV control rooms, etc.) need not comply with this Guide so long as the modules are unmanned during heavy weather and sufficient space for the entire complement of personnel assigned to work in the unit(s) is provided in a deckhouse, superstructure, or module complying fully with applicable structural requirements. A notice indicating the same is to be affixed to the module.

Industrial modules are to comply with Appendix 7-2-A2 of the ABS MODU Rules or Appendix 7-A-17 of the ABS Rules for Survey After Construction (Part 7), as applicable.

Non-sleeping accommodation modules are to comply with this Guide. However, the structural requirements of this Guide need not apply so long as the same conditions listed above for industrial modules are met. If non-sleeping accommodation modules are stacked, the stacking arrangements are to be reviewed and surveyed in accordance with this Guide.

Containers or portable buildings provided for storage or to house miscellaneous industrial equipment need not be considered class items. This Guide may be applied on a voluntary basis. *The equipment installed in such containers or portable buildings may however be subject to additional requirements within other ABS Rules.* Equipment essential to the operation of the vessel is not considered miscellaneous industrial equipment.

This Guide is not applicable to modular buildings which protect against down flooding or those considered buoyant in stability or load line calculations.

This Guide is not applicable to accommodation modules intended for Passenger Vessels or Special Purpose Ships carrying more than 60 persons. Modules intended for installation onboard this type of vessel are subject to additional requirements and will be considered on a case by case basis.

This Guide is intended for modules generally not to exceed length, width, and height dimensions of 14 × 4.9 × 3 m (46 × 16 × 10 ft).

Modules constructed on or after 15 January 2013 are to comply with the requirements contained herein. Existing modules to be installed onboard ABS classed units or vessels after 1 January 2018 are to comply with this Guide.

7 Class Approval Process (1 May 2014)

The ABS approval process for accommodation modules is a four-step process as outlined below:

- Design Review of the Module Section 2
- Survey of the Module at Fabrication Facility Section 3
- Design Review for Installation Approval Section 4
- Survey onboard Host Vessel Section 5

The ABS review process of the module commences with drawings and documentation detailing the module's general arrangements, structural fire protection, electrical configuration, structural design, and machinery and piping systems being submitted to the ABS technical office for review. Upon completion of the review, drawings will be returned to the submitter and forwarded to the attending ABS Surveyor. Receipt of the drawings by the ABS Surveyor permits the physical survey of the module at the fabrication facility to be commenced.

Once a host vessel for the module is determined, design review for installation approval can be commenced. Upon receipt of the documentation detailing the module and the proposed location onboard the host vessel, the ABS technical office can review the arrangements. Once the ABS engineers have determined that the proposed location onboard the host vessel is suitable for the subject module, stamped drawings will be returned to the submitter and made available to the attending ABS Survey office. Upon receipt of these drawings, the attending ABS Surveyor may attend the vessel and confirm that the installation of the modules is in accordance with the approved arrangements.

The manufacturer is to assign a unique serial number to identify all modules being reviewed to this Guide. The initial submission of drawings is to specifically indicate the serial number of modules to be built in accordance with the drawings.

9 Definitions

Accommodation Module. Space used for sleeping cabins, offices, hospitals, cinemas, games and hobby rooms, barber shops, halls, dining rooms, lounges, corridors, lavatories, pantries, galleys, and similar spaces. Laundries and storage rooms are not considered accommodation buildings.

Industrial Module. Spaces used for industrial activities such as laboratories, workshops, wireline units, mudloggers, ROV control rooms, etc. Industrial modules may contain office space and still be considered an industrial module.

Sleeping Accommodation Module. Spaces used for sleeping cabins and hospitals. Offices, cinemas, games and hobby rooms, barber shops, halls, dining rooms, lounges, corridors, lavatories, pantries, galleys, and similar spaces are not considered sleeping accommodation modules.

Protected Front. The front of the module is considered protected if it fully sits within the space enclosed by lines drawn aftwards and inwards 45 degrees from the corners of an adjacent effective structure (for example, forecastle aft bulkhead). See Section 1, Figure 1.

Where the aft deck of an Offshore Support Vessel is protected by wing walls, the forward bulkhead of all first tier modules may be considered "protected front". The height of the wing walls are to be not less than the standard height of superstructures, as defined in Annex I, Regulation 33 of International Conventions on Load Lines.

Unprotected Front. The front of the module is considered unprotected if it sits outside the locations defined as protected front

FIGURE 1
Illustration of Protected and Unprotected Front Bulkheads

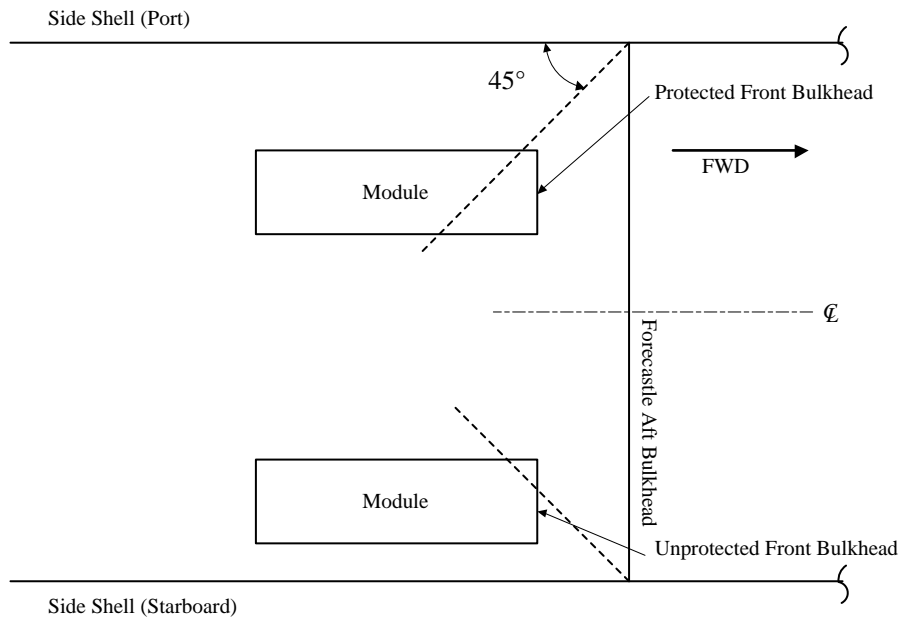



SECTION 2 Design Review of Module

1 General

Drawings detailing the module's general arrangements, structural fire protection, electrical configuration, structural design, and machinery and piping systems are to be submitted for review. The specific drawings and details to be submitted are dependent on the type of module. The information below presents the typical drawings and details to be submitted for each discipline dependent on the end use of the module.

3 Plans and Data to be Submitted

The following plans and data are to be submitted:

- Structural fire protection plan
- Joiner work details
- Ventilation plan – including penetration details, capacities and alarm arrangements. See Subsection 2/11 and 2/15.17.
- Public address system (PA). See 2/15.5.
- General alarm system(GA). See 2/15.7.
- Combined PA/GA. See 2/15.9.
- Module Internal Electrical System One-Line diagram
- Fire detection and alarm systems. See 2/15.15.
- Booklet of basic electrical details. See 2/15.21.1.
- Cable connection and penetration arrangements.
- General arrangement of piping within the module (Section 4-6-1 of the *Steel Vessel Rules*)
 - Metallic piping (Section 4-6-2 of the *Steel Vessel Rules*)
 - Plastic piping (Section 4-6-3 of the *Steel Vessel Rules*)
- Sanitary system details (Sections 4-6-1 and 4-6-2 or Section 4-6-3 of the *Steel Vessel Rules*)
- Compressed air systems (appropriate requirements of 4-6-7/5 of the *Steel Vessel Rules*)
- Deck drains and scuppers (4-6-4/3 of the *Steel Vessel Rules*)
- Potable water system where applicable (Sections 4-6-1 and 4-6-2 or Section 4-6-3 of the *Steel Vessel Rules*)
- Other piping systems not listed above depending on type and service (Sections 4-6-1 and 4-6-2 or Section 4-6-3 of the *Steel Vessel Rules*)
- Diagrammatic plan of the piping systems including design pressure and temperature of the systems and a bill of materials with the following details: material specification (type and grade), pressure rating, wall thickness, and standards of construction for all piping components
- Firefighting equipment, where applicable
- Fire control plan, where applicable
- Structural drawings (section, elevation, decks, etc.)

- Structural calculations (racking, deck loads, etc.)
- Structural details of windows and doors

Where applicable the following plans and data are to be submitted:

- Instrumentation system wiring diagram for monitoring, control and safety system wiring, if provided
- Walk-in refrigerator locked-in alarm. See 2/15.13.
- Hazardous area protection arrangements – including required alarms. See 2/15.19.

5 Structural Fire Protection Requirements

5.1 General

All portable accommodation modules certified by ABS are to meet the requirements of this section.

This Subsection is applicable to modules whose exterior boundaries are constructed of steel. Use of other materials is subject to special consideration. Modules designed to a recognized standard for a special vessel type (i.e., High Speed Craft) may be approved with appropriate service restrictions.

Special consideration will be given to modules that contain stairways as defined in 2/9.3(4). Modules containing control stations are not covered by this section and should be designed in accordance with the applicable requirements of SOLAS Chapter II-2 or the Rules to which the host vessel is subjected.

This Guide is intended for modules incorporating Method IC construction as defined by SOLAS. Special consideration may be given to acceptance of other methods so long as appropriate fire detection, alarm, and sprinkler systems are provided.

Reference is to be made to SOLAS and the International Code for Application of Fire Test Procedures (Resolution MSC.307(88)) (FTP Code).

5.3 Administration Review

Where the module has been certified by an Administration, the same may be considered for acceptance by ABS in place of review to this section. Any limits to the Administration review and the acceptance criteria used are to be appropriately reflected in the module approval letter.

7 Materials of Construction

7.1 Primary Deck Coverings

Primary deck coverings, if applied within accommodation and service spaces, are to be of approved material which will not readily ignite or give rise to smoke or toxic or explosive hazards at elevated temperatures, this being determined in accordance with the Fire Test Procedures Code.

7.3 Insulating Materials

Insulating materials are to be non-combustible.

Insulating materials are to be attached to the module boundaries using welded steel pins and clips unless an alternative arrangement has been approved.

Vapor barriers and adhesives used in conjunction with insulation, as well as the insulation of pipe fittings for cold service systems, need not be of noncombustible materials, but they are to be kept to the minimum quantity practicable and their exposed surfaces are to have low flame-spread characteristics.

7.5 Ceilings and Linings

All linings, ceilings, draught stops and their associated grounds are to be of noncombustible materials.

7.7 Use of Combustible Materials

Noncombustible bulkheads, ceilings and linings fitted in accommodation and service spaces may be faced with combustible materials, facings, moldings, decorations and veneers provided such spaces are bounded by noncombustible bulkheads, ceilings and linings in accordance with the provisions of 2/7.9 to 2/7.11 and 2/7.15.

7.9 Maximum Calorific Value of Combustible Materials

Combustible materials used on the surfaces and linings specified in 2/7.7 are to have a calorific value* not exceeding 45 MJ/m² of the area for the thickness used. The requirements of this paragraph are not applicable to the surfaces of furniture fixed to linings or bulkheads.

* Refer to the recommendations published by the International Organization for Standardization, in particular ISO 1716, Reaction to fire tests for building and transport products – Determination of the heat of combustion.

7.11 Total Volume of Combustible Materials

Where combustible materials are used in accordance with 2/7.7, they are to comply with the following requirements:

- i) The total volume of combustible facings, moldings, decorations and veneers in accommodation and service spaces is not to exceed a volume equivalent to 2.5 mm veneer on the combined area of the walls and ceiling linings. Furniture fixed to linings, bulkheads or decks need not be included in the calculation of the total volume of combustible materials; and
- ii) In the case of modules fitted with an automatic sprinkler system complying with the provisions of the Fire Safety Systems Code, the above volume may include some combustible material used for erection of “C” class divisions.

7.13 Low Flame-spread Characteristics of Exposed Surfaces

The following surfaces are to have low flame-spread characteristics in accordance with the Fire Test Procedures Code:

- i) Exposed surfaces in corridors and ceilings in accommodation and service spaces and control stations; and
- ii) Surfaces and grounds in concealed or inaccessible spaces in accommodation and service spaces and control stations.

7.15 Paints, Varnishes and Other Finishes

Paints, varnishes and other finishes used on exposed interior surfaces are not to be capable of producing excessive quantities of smoke and toxic products, this being determined in accordance with the Fire Test Procedures Code.

7.17 Materials Containing Asbestos

Installation of materials which contain asbestos is prohibited.

9 Fire Integrity

9.1 Fire Integrity of Exterior Boundaries (1 July 2016)

The exterior boundaries are to be steel but are not required to be of “A” class standard. **However, external doors are to be self-closing and at least “A-0” class standard.**

If the module is to be rated “A-0”, “A-60”, or “H-60”, exterior boundaries are to be constructed of minimum 4 mm thick steel with the appropriate insulation. Alternatives may be considered where appropriate testing has been carried out.

Reference should also be made to the special requirements contained in Subsection 2/13.

See Chapter 2, Section 1 of the *ABS Rules for Building and Classing Facilities on Offshore Installations (Facilities Rules)* for the definition of “H-60” divisions.

Where a boundary is penetrated for the passage of electric cables, pipes and vent ducts, such penetrations are to maintain the integrity of the boundary penetrated.

9.3 Fire Integrity of Interior Bulkheads (1 July 2016)

The minimum fire integrity of interior bulkheads is to be as prescribed by Section 2, Table 1 for spaces typical to accommodation modules. Reference is to be made to SOLAS Chapter II-2 for spaces not included.

The division between a Category A Machinery Space and an adjacent space is to be A-60. However, if the adjacent space is an Other Machinery Space, the bulkhead may be reduced to A-0.

The following requirements are to govern application of the table:

For determining the appropriate fire integrity standards to be applied to divisions between adjacent spaces, such spaces are classified according to their fire risk, as shown in Categories (1) to (9) below. The title of each category is intended to be typical rather than restrictive. The number in parenthesis preceding each category refers to the applicable column or row in the table. Spaces not contained in Table 1 will be subject to special consideration:

- (1) *Control Stations* are those spaces in which
 - Emergency sources of power and lighting are contained
 - Wheelhouse, chartroom, radio room, or where main navigation equipment is located
 - The fire monitoring and alarm or fire control equipment is centralized or fire-extinguishing systems serving various locations are situated
 - Dynamic positioning system or propulsion machinery controls are located
 - The centralized ballast control station in column-stabilized units is situated.
- (2) *Corridors* means corridors and lobbies.
- (3) *Accommodation Spaces* are those used for public spaces, cabins, offices, hospitals, cinemas, game and hobby rooms and similar spaces. Public spaces are those portions of the accommodation which are used for meeting halls, dining rooms, lounges and similar permanently enclosed spaces. Accommodation Spaces include communal sanitary facilities such as showers, baths, lavatories, etc., and isolated pantries containing no cooking appliances. Sanitary facilities which serve a space and with access only from that space are to be considered a portion of the space in which they are located.
- (4) *Stairways* are interior stairways, lifts and escalators and enclosures thereto. In this connection, a stairway which is enclosed only at one level is regarded as part of the space from which it is not separated by a fire door.
- (5) *Service Spaces (low risk)* are lockers, storerooms and working spaces in which flammable materials are not stored; drying rooms, laundries; refrigerating, ventilation and air-conditioning machinery spaces with motors having an aggregate capacity not greater than 7.5 kW (10 hp).
- (6) *Machinery Spaces of Category A* are all spaces which contain internal combustion type machinery used either:
 - For main propulsion or
 - For other purposes where such machinery has in the aggregate a total power of not less than 375 kW (500 hp) or which contain any oil-fired boiler or oil fuel unit; and trunks to such spaces.
- (7) *Other Machinery Spaces* are those spaces, including trunks to such spaces, containing propulsion machinery, steam and internal combustion engines, generators and major electrical machinery (SCR, MCC and switchgear); oil filling station; refrigerating, ventilation and air-conditioning machinery with motors having an aggregate capacity greater than 7.5 kW (10 hp); and similar spaces, but are not machinery spaces of Category A.
- (8) *Cargo Spaces*
- (9) *Service Spaces (high risk)* are lockers, storerooms and working spaces in which flammable materials are stored, galleys, pantries containing cooking appliances, paint rooms and workshops other than those forming part of the machinery space.

TABLE 1
Fire Integrity of Bulkheads Separating Adjacent Spaces

<i>Spaces</i>	(2)	(3)	(5)	(7)	(9)
Corridors (2)	C	B-0	B-0	A-0	A-0
Accommodation Spaces (3)		C	B-0	A-0	A-0
Service Spaces (low risk) (5)			C	A-0	A-0
Other Machinery Spaces (7)				A-0 ^(1,2)	A-0
Service Spaces (high risk) (9)					A-0 ⁽²⁾

Notes:

- 1 Where the space contains an emergency power source or components of an emergency power source that adjoins a space containing a unit's service generator or the components of a unit's service generator, the boundary bulkhead or deck between those spaces is to be an "A-60" Class division.
- 2 Where spaces are of the same numerical category and superscript (2) appears, a bulkhead of the rating shown in the tables is only required when the adjacent spaces are for a different purpose (e.g., in category (9), a galley next to a galley does not require a bulkhead, but a galley next to a paint room requires an "A-0" bulkhead). Where a bulkhead is installed between two spaces of the same numerical category which are for the same purpose, the separating bulkhead is to be made of noncombustible material (except for spaces separated for redundancy in units with **DPS-3** notation, where the separating bulkhead is to be "A-60" rating).

Note: Class "A" or Class "B" divisions and their associated insulation index are as defined in SOLAS Regulation II-2/3.2 or 3.4, respectively.

All bulkheads forming "B" Class divisions are to extend from deck to deck and to the deckhouse side or other boundaries, unless continuous "B" Class ceilings and/or linings are fitted on both sides of the bulkhead, in which case the bulkhead may terminate at the continuous ceiling or lining. In corridor bulkheads, ventilation openings are to be provided only in and under the doors of cabins, public spaces, offices and sanitary spaces. The openings are to be provided only in the lower half of the door. Any such opening in or under a door is to have a total net opening no larger than 0.05 m² (0.54 ft²) and is to be fitted with a noncombustible grill.

The fire resistance of doors is to be equivalent to that of the division in which they are fitted.

Structural fire protection details are to avoid the risk of heat transmission at intersections and terminal points of required thermal barriers. The insulation of a deck or bulkhead is to be carried past the penetration, intersection or terminal point for a distance of at least 450 mm in the case of steel and aluminum structures.

If a space is divided with a bulkhead of "A" class standard having insulation of different values, the insulation with the higher value is to continue on the deck or bulkhead with the insulation of the lesser value for a distance of at least 450 mm.

9.5 Fire Integrity of Decks

The fire integrity of the top and bottom decks are to be steel or equivalent unless the module is intended to be installed above or below a Category A Machinery Space, control station, or ro-ro vehicle space in which case the common boundary is to be insulated to A-60 standard.

9.7 Penetrations of Cables (1 July 2016)

Where cables pass through watertight, fire-tight, or smoke-tight bulkheads or decks, the penetrations are to be made through the use of approved stuffing tubes, transit devices or pourable materials installed in accordance with manufacturer's installation procedures to maintain the watertight integrity or fire-rating of the bulkheads or decks. These devices or pourable materials are not to damage the cable physically or through chemical action or through heat build-up. After installation, all watertight and fire-rated cable penetrations are to be visually examined and tested in presence of and to the satisfactions of the attending Surveyor. Where cable conduit pipe or equivalent is carried through decks or bulkheads, arrangements are to be made to maintain the integrity of the water, fire or gas tightness of the structure.

9.9 Penetration of Piping (1 July 2016)

9.9.1 General

Where pipes penetrate bulkheads and decks which are required to be fire-tight or smoke-tight, the penetrations are to be made by approved methods which will maintain the same degree of fire-tight or smoke-tight integrity.

9.9.2 Pipes Penetrating “A” Class Divisions

Where pipes penetrate “A” class divisions, such penetrations are to be tested in accordance with the Fire Test Procedures Code. If the penetration is constructed of steel or fitted with a steel sleeve at least 3 mm thick and at least 900 mm (35.4 in.) long (preferably 450 mm (17.7 in.) on each side of the division) and provided with fire insulation having the same length and fire integrity as the division, testing is not required.

Uninsulated metallic pipes penetrating “A” class divisions are to be of materials having a melting temperature which exceeds 950°C (1742°F).

9.9.3 Pipes Penetrating “B” Class Divisions

Where pipes penetrate “B” class divisions, such penetrations are to be tested in accordance with the Fire Test Procedures Code. Testing is not required however if:

- i)* Pipes having diameters greater than or equal to 150 mm (5.91 in.) penetrating “B” class divisions are steel or lined with steel sleeves at least 1.8 mm (0.07 in.) thick and at least 900 mm (35.4 in.) long (preferably 450 mm (17.7 in.) on each side of the division).
- ii)* Pipes having diameters less than 150 mm (5.91 in.) are to be steel or lined with steel sleeves at least 1.8 mm (0.07 in.) thick and at least 600 mm (23.6 in.) long (preferably 300 mm (11.81 in.) on each side of division).
- iii)* Pipes other than steel or copper are connected to the ends of the sleeve defined in *i)* and *ii)* by flanges or couplings; or the clearance between the sleeve and the pipe is not to exceed 2.5 mm (0.10 in.); or any clearance between pipe and sleeve is to be made tight by means of non-combustible or other suitable material.

Uninsulated metallic pipes (including copper) penetrating “B” class divisions have a melting temperature which exceeds 850°C (1562°F).

11 Ventilation

11.1 General

Ventilation ducts are to be of steel or other equivalent material.

11.3 Means for Closing

The main inlets and outlets of all ventilation systems are to be capable of being closed from outside the spaces being ventilated. The means of closing are to be easily accessible as well as prominently and permanently marked and are to indicate whether the shut-off is open or closed.

11.5 Power Ventilation

Power ventilation is to be capable of being stopped from an easily accessible position outside the space being served. This position is not to be readily cut off in the event of a fire in the spaces served. See also 2/15.17.

11.7 Penetrations of Vent Ducts

Where a boundary is penetrated for the passage of vent ducts, such penetrations should be made tight to prevent the passage of flame and smoke.

Ventilation ducts having an internal cross-sectional area greater than 0.02 m² (0.22 ft²) penetrating “A” class divisions are to be steel or lined with a steel sheet sleeve, that is at least 3 mm (0.118 in.) thick and at least 900 mm (35.4 in.) long (preferably 450 mm (17.7 in.) on each side of the division), provided with fire insulation having the same fire integrity as the division.

Those ducts exceeding 0.075 m² (0.81 ft²), except those serving hazardous areas, are to also have an automatic fire damper capable of being closed manually from both sides of the bulkhead or deck and with a position indicator which shows whether the damper is open or closed. The fire dampers are not required where ducts pass through spaces surrounded by “A” class divisions, without serving those spaces, provided those ducts have the same fire integrity as the divisions which they penetrate.

Ventilation ducts less than or equal to 0.02 m² (0.22 ft²) penetrating “A” class divisions are to be steel, or lined with steel sheet sleeves that are at least 3 mm thick and at least 200 mm (7.88 in.) long preferably 100 mm (3.93 in.) on each side of bulkhead or, in the case of the deck, wholly laid on the lower side of the deck that is pierced and provided with fire insulation having the same fire integrity as the division. See Section 2, Figure 1.

Ventilation ducts with a free cross-sectional area exceeding 0.02 m² passing through “B” class bulkheads are to be lined with steel sheet sleeves of 900 mm in length, divided preferably into 450 mm on each side of the bulkhead unless the duct is of steel for this length.

FIGURE 1
Ventilation Ducts Penetrating “A” Class Divisions

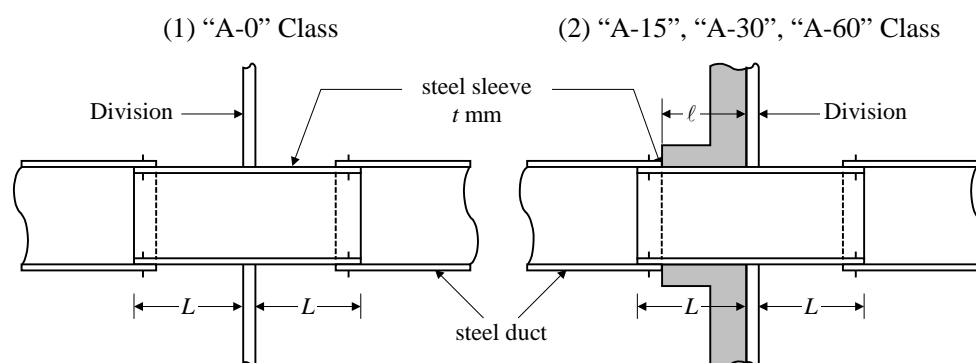

	<i>L</i> mm (in.)	<i>l</i> mm (in.)	<i>t</i> mm (in.)	Automatic Damper**
$S > 750 \text{ cm}^2$	450 (17.7)	450 (17.7)	3.0 (0.19)	Required *
$750 \text{ cm}^2 \geq S > 200 \text{ cm}^2$	450 (17.7)	450 (17.7)	3.0 (0.19)	Not required
$200 \text{ cm}^2 \geq S$	min. 100 (3.94)	min. 100 (3.94)	3.0 (0.19)	Not required

* Not required if duct passes through spaces surrounded by "A" class divisions, without serving those spaces, provided the duct has the same fire integrity as the divisions it pierces.

** Automatic fire damper capable of being closed manually from both sides of the division.

S = Sectional area of duct

13 Special Requirements

13.1 Category A Machinery Space

The exterior of a module that contains a Category A Machinery Space is to be surrounded by A-60 boundaries unless the module is restricted from being installed adjacent to other modules, deckhouses, or superstructure.

The interior division between a Category A Machinery Space and an adjacent space within the module is to be A-60. However, if the adjacent space is an Other Machinery Space, the bulkhead may be reduced to A-0.

13.3 MODUs

13.3.1 Hazardous Areas

Exterior boundaries are to be “A-60” Class for the whole of the portion which faces and is within 30 m (98 ft) of the center of the rotary table. The 30 m (98 ft) is measured with the rotary at its closest drilling position to the accommodation. If the exterior is not constructed of “A-60”, an appropriate restriction is to be noted on the module approval letter.

13.3.2 Accommodation Spaces adjacent to Hazardous Areas

Modules intended to be installed adjacent to hazardous areas on MODUs complying with the ABS *MODU Rules*, 2012 or later or the 2009 IMO MODU Code are to be provided with blast resistance in accordance with 5-1-1/5 of the ABS *MODU Rules*, 2012.

13.5 Offshore Production Installations

“H-60” ratings are required for the module exterior bulkheads that face areas such as wellheads, oil storage tanks, fired vessels (heaters), crude oil processing vessels, and other similar hazards. If such bulkhead is more than 33 m (100 ft) from this source, then this can be relaxed to an “H-0” rating. This may be relaxed as outlined in 3-3/5 of the *Facilities Rules*.

Modules are not to be located above or below crude oil storage tanks or process areas.

13.7 Oil Tankers

Modules are to be installed in a protected location aft of the deckhouse.

13.9 Ro-Ro and Vehicle Spaces

Modules installed directly above or adjacent to ro-ro or vehicle spaces are to be insulated to A-60 standard for the adjacent boundary.

13.11 Galleys

Ventilation and exhaust ducts serving the galley range are to be in accordance with SOLAS Chapter II-2 Regulation 9.7.2 and 9.7.5.

15 Electrical Requirements

15.1 General

This Subsection gives requirements for the electrical and communication aspects of the portable modules, including fire detection and alarm and PA/GA.

Given the variability in the host vessels and portable modules, it is important that the overall safety of the combination of the host vessel and portable module is considered when applying the electrical requirements that follow. While this section covers the portable module, reference should also be made to Section 4 on ‘Installation’ in order to be aware of all of the electrical and communication requirements applicable to the combined unit.

High voltage systems should not be used on portable modules or for their interconnection to the host vessel. Where the electrical loads are such that the operation or interconnection at less than 1,000 V is not practicable, then special consideration can be given to the use of high voltages.

15.3 Principles for Electrical Protection

The electrical equipment and systems used within the portable module will generally be those for lighting, ventilation, computer systems, communication, safety systems, etc. Due to the range of possible module types and applications and the number of potential host vessels, it is not possible to give a definitive list of the equipment that will be required to be installed in the module.

In general, the *Steel Vessel Rules* or the *MODU Rules* are to be used in the design, construction and installation of the electrical equipment.

Where there is a conflict or inconsistency in design approaches (e.g., hazardous area equipment, earthed vs. unearthed systems, conduit vs. braided cable), the acceptability of the portable module for the host vessel will need to be considered on a case-by-case basis. Reference should be made to Section 4 of this Guide.

It is to be established that:

- i) The electrical equipment and cables on the portable module are adequately sized for their design loads and protected against overload and short circuit.
- ii) The over-current protection will need to be coordinated with the host vessel electrical system such that a fault in the electrical system on the module does not affect the coordinated tripping of the host vessel's electrical protection system; however, any sub-distribution or reduction in cable size on the portable module will need to be protected at the point of sub-distribution or reduction in cable size.
- iii) Socket outlets for portable accessories in bathrooms or wet areas are to be protected by Ground Fault Circuit Interrupter (GFCI)-type outlets or a general earth leakage or residual current detection device for the safety of personnel.
- iv) Unused socket outlets used in wet areas are to be provided with covers to maintain their IP rating:
 - a) Unused socket outlets in galleys and laundries are to be provided with covers so as to have a minimum IP-44 degree of protection.
 - b) Unused socket outlets in bathrooms and showers or those exposed to external weather conditions are to be provided with covers so as to have a minimum of IP-55 degree of protection.

15.5 Public Address (PA)

A public address (PA) system is to be provided and made capable of connection to the host vessel.

Speakers are to be arranged such that the PA announcements are clearly audible in all parts of the portable module and provided with an override function so that all emergency messages may still be broadcast to any loudspeaker even when the speaker has been turned off, its volume reduced or the system is in use for other purposes.

With the host vessel operating in any of its normal operating modes, the minimum sound levels for broadcasting emergency announcements are to be:

- i) In interior locations, 75 dB (A) and at least 20 dB (A) above the speech interference level
- ii) In exterior locations, 80 dB (A) and at least 15 dB (A) above the speech interference level

Whenever possible, the power for the PA system is to be supplied from the host vessel system. In cases where the power is not supplied from the host vessel, the requirements stated in 4-8-2/11.5.5 of the *Steel Vessel Rules* are to be applied.

Where the PA is provided by speakers connected to an amplifier provided in the portable unit, the arrangements are to be made to provide power to the amplifier in the event of main power failure. This may be provided by either a feed from the host vessel's emergency power system or a battery/UPS with at least 18 hours of capacity.

15.7 General Alarm (GA)

Devices for sounding the general alarm (GA) are to be provided and made capable of connecting to a host vessel. Alarm signal devices are to produce a distinctive and loud sound. The system is to be clearly audible in all parts of the portable module. The sound pressure level in the module sleeping position and in module bathrooms is to be at least 75 dB(A) and at least 10 dB(A) above ambient noise level. Where these sound levels cannot be met, a bell or alarm transducer is to be provided.

Where the host vessel's GA system is designed and installed such that it can be heard in all areas of the portable module, even in the noisiest vessel operating mode, then the portable module does not need to be fitted with its own GA sounding devices. This is to be demonstrated to the satisfaction of the attending Surveyor following installation.

The sounding devices should preferably be of the same type (e.g., bells) as those installed on the host vessel in order to avoid the introduction of inconsistent or confusing alarm sounds. In any case, the same sound is not to be associated with different required personnel actions.

Where the GA is provided by speakers connected to an amplifier provided in the portable unit, arrangements are to be made to provide power to the amplifier in the event of main power failure. This may be provided by either a feed from the host vessel's emergency power system or a battery/UPS with at least 18 hours of capacity.

15.9 Combined PA/GA

Where a single system serves as both public address and general alarm, the system is to be arranged such that a single failure within the portable module will not cause the loss of both systems and will minimize the effect of a single failure. Compatibility with the PA/GA system on the host vessel is to be such that a failure in the portable module or on the cables connecting the host vessel to the portable module will not lead to a reduction in the effectiveness of the system on the host vessel. The power for the combined PA/GA system is to be supplied from the host vessel system. In cases where the power is not supplied from the host vessel, the requirements stated in 4-8-2/11.5.5* of the *Steel Vessel Rules* are to be applied.

* *Note:* The use of a combined system to provide the alarm for fire results in specific, and usually more onerous, power supply requirements.

15.11 Emergency Lighting

In module internal public spaces, such as those portions of the accommodation which are used for meeting halls, dining rooms, lounges and corridors, emergency lighting is to be provided for at least the same duration as required for the host vessel. A separate emergency lighting panel is to be provided for integration to the host vessel emergency power distribution system. Alternatively, use of relay-controlled, battery-operated lanterns is acceptable provided the batteries are automatically recharged and the battery-operated lamps provide light for the same period as required for the host vessel.

15.13 Refrigerated Spaces – Locked-In Alarm

Walk-in refrigerated spaces are to be provided with a device capable of activating an audible and visual alarm in a manned control position on the host vessel.

15.15 Fire Detection and Alarm System

Accommodation spaces and service spaces are to be covered by an automatic fire detection system, following a Method IC method of protection, as defined in SOLAS Regulation 9.2.3.1.1. The system is to be capable of being interfaced with the host vessel's fire detection system such that the initiating detector location is capable of being identified on the host vessel's fire detection panel. Alternatively, a display panel that is provided with the portable module and which can be installed close to the host vessel's fire detection display panel will be considered.

A sufficient number of manual call points for the fire alarm are to be fitted at suitable locations throughout the portable accommodation module. Manually-operated call points are to be located throughout the different areas within the portable accommodation module. One manual call point for fire alarm is to be provided at each exit of the portable accommodation module. Manually-operated call points are to be readily accessible in all corridors throughout the portable accommodation module such that no part of a corridor is more than 20 m (66 ft) from a manually-operated call point.

The power for the fire detection and alarm system is to be supplied from the host vessel system. In cases where the power is not supplied from the host vessel, the requirements stated in 4-7-3/11.1.3 of the *Steel Vessel Rules* are to be applied.

15.17 Ventilation

Mechanical ventilation systems are to be provided with means for stopping the ventilation in the case of fire or other emergency. The means of stopping the fans is to be located in an accessible position leading to but outside of the portable module. See also 2/11.1 and 2/11.3.

If the host vessel is fitted with a means of automatically shutting down ventilation after combustible gas detection at the air intake, then the portable module is to be capable of operating in a manner consistent with this philosophy. Consideration should be given to making suitable, accessible, marked terminals available for this purpose.

15.19 Hazardous Areas

Portable modules are not to be installed in hazardous areas and their ventilation intakes, exhausts or other openings are not to be within the hazardous area. See Section 4 for other hazardous area requirements.

15.21 Document Packages

Documentation for the electrical design and installation is to be maintained with the portable module in order that it can be established that the equipment is suitable for connection on board. The following documentation packages are to be provided.

15.21.1 Basic Electrical Details

A booklet, or equivalent, containing basic electrical details of the portable module, including:

- Rated Voltage and allowable variations
- Frequency
- Power requirements and electrical load analysis
- Earthing requirements
- Maximum allowable short circuit power level at the point of connection
- Details of any exceptional electrical features (e.g., large power factors, starting currents or nonlinear loads)
- Cable connection and penetration arrangements
- Instructions for connection of the portable module
- Power system wiring diagram including data of circuit protection devices, emergency shutdown system, cable designation and ampacity, etc.
- Lighting system wiring diagram
- Communication system wiring diagram
- Instrumentation system wiring diagram for monitoring, control and safety system wiring, if provided.
- Arrangement of electric equipment
- Public address system (PA). See 2/15.5.
- General alarm system (GA). See 2/15.7.
- Fire detection and alarm systems. See 2/15.15.
- Ventilation arrangements – including capacities and alarm arrangements. See 2/11.1, 2/11.3, and 2/15.17.

15.21.2 Batteries

Where batteries are part of the portable module and provide services essential for the safety of the module or personnel, then a list is to be maintained which includes:

- Type
- Voltage
- Rated capacity
- Conductor protection
- Charging and discharging arrangements
- Required maintenance and a log for evidence of maintenance

17 Piping Requirements

In general, piping is to be in accordance with Part 4, Chapter 6 of the *Steel Vessel Rules*. The documents listed in Subsection 2/3 are to be submitted where applicable.

Information to be submitted with each system is to include a diagrammatic plan of the piping systems, which includes the design pressure and temperature of the systems and a bill of materials with the following details: material specification (type and grade), pressure rating, wall thickness, and standards of construction for all piping components.

19 Fire Fighting Requirements

In general, at least one portable fire extinguisher is to be easily accessible and located inside each module. In addition, machinery modules of category A containing internal combustion machinery are to be provided with a fixed fire extinguishing system.

When installed on the appropriate type vessels or offshore units, details of the portable fire extinguishers and fixed fire extinguishing system are to be in accordance with:

- Part 4, Chapter 7 of the *Steel Vessel Rules*
- Part 4, Chapter 7 of the *ABS Rules for Building and Classing Offshore Support Vessels (OSV Rules)*
- Part 4, Chapter 5 of the *ABS Rules for Building and Classing Steel Vessels Under 90 Meters in Length (Under 90m Rules)*
- Part 3, Chapter 5 of the *ABS Rules for Building and Classing Steel Barges (Barge Rules)*
- Part 5 of the *MODU Rules*; or
- Chapter 3, Section 8 and Chapter 4, Section 8 of the *Facilities Rules*

The following documents are to be submitted where applicable:

- Firefighting equipment
- Fire control plan

21 Machinery Requirements

Prime movers rated at or greater than 100 kW (135 hp) driving equipment essential to the operation of the vessel (see Subsection 1/9) are to be unit certified in accordance with Part 4, Chapter 2 of the *Steel Vessel Rules*. Unit certification consists of:

- Design review by ABS
- Materials tests witnessed by Surveyor
- Survey at the plant of manufacture including witnessing acceptance tests on production unit, and
- Type/prototype testing conducted on an actual sample or a prototype model, as applicable

Diesel engines are to comply with appropriate regulations of MARPOL, Annex VI.

23 Structural Requirements

23.1 General

The scantlings of the exposed bulkheads, decks, doors, and windows of accommodation modules are to be in accordance with this section. Reference should also be made to the structural requirements contained in Section 4 applicable to the installation onboard a specific vessel.

The following bulkhead plating, stiffener, corrugated bulkhead, and window requirements are based on a design head “*h*”. It is the responsibility of the module designer or fabricator to specify the appropriate design head “*h*” for which the review is to be carried out. As outlined in Section 4, the design head of the module is to exceed the head in the location onboard the specific vessel or unit as calculated in accordance with the applicable ABS Rules. Note that the design head “*h*” can vary for bulkheads in different locations (such as front bulkhead and side bulkhead) and a list of typical values provided in the following table may be used for guidance. These typical values are based on the assumption that the modules will not be installed within 10% of the breadth of the vessel from the side and will not be installed in the forward 25% of the length of the vessel:

TABLE 2
Typical Design Head Values (1 May 2014)

a) SI Unit and MKS Units (m)

<i>Vessel Type</i>	<i>Unprotected front, lowest tier</i>	<i>Side, Aft end, Protected front, lowest tier</i>	<i>Unprotected front, other than lowest tier</i>	<i>Protected front, Sides, and Aft ends, other than lowest tier</i>
SEDU	11.0 ⁽²⁾	7.0 ⁽²⁾	1.0	1.0
CSDU	1.0	1.0	1.0	1.0
OSV ⁽¹⁾	9.9	4.0	3.0	2.0
Barge ⁽¹⁾	9.8	5.9	4.9	2.9
Tanker/FPSO/Drillship	16.8	8.3	3.9	3.0

b) US Units (ft)

<i>Vessel Type</i>	<i>Unprotected front, lowest tier</i>	<i>Side, Aft end, Protected front, lowest tier</i>	<i>Unprotected front, other than lowest tier</i>	<i>Protected front, Sides, and Aft ends, other than lowest tier</i>
SEDU	36.1 ⁽²⁾	23.0 ⁽²⁾	3.3	3.3
CSDU	3.3	3.3	3.3	3.3
OSV ⁽¹⁾	32.5	13.1	9.8	6.7
Barge ⁽¹⁾	32.3	19.4	16.1	9.7
Tanker/FPSO/Drillship	55.2	27.4	12.8	9.7

Notes:

- 1 A 90 m (295 ft) OSV and barge were considered. For larger vessels a higher “*h*” may be appropriate
- 2 (1 May 2014) For Portable Accommodation Modules installed on the lowest tier SEDUs “*h*” may be taken as 1 m (3.3 ft) if the Modules are unmanned while afloat. However, the full design head should be considered for securing to the deck.

23.3 Side and End Bulkhead Plating (1 July 2016)

23.3.1 Steel Plating

The steel plating is to be not less in thickness than that obtained from the following equation:

$$t = 3s\sqrt{h} \text{ mm}$$

$$t = s\sqrt{h}/50 \text{ in.}$$

where

- s* = spacing of stiffeners, in m (ft)
- h* = design head specified by designer, in m (ft)

Any steel plating considered effective in the stacking or racking analysis is required to have a minimum thickness of 5.0 mm (0.2 in.).

In no case is the plating thickness for steel to be less than 3.0 mm (0.12 in.).

23.3.2 Aluminum Plating

In the case of aluminum plating, the minimum thicknesses t_{alum} is to be obtained from the following:

$$t_{alum} = t \times \sqrt[3]{\frac{E_{steel}}{E_{aluminum}}}$$

where

- t = minimum required steel plating thickness as defined in the above
- E_{steel} = Young's modulus of elasticity of steel
- $E_{aluminum}$ = Young's modulus of elasticity of aluminum

23.5 Side and End Bulkhead Stiffeners

Each stiffener, in association with the plating to which it is attached, is to have section modulus SM not less than that obtained from the following equation:

$$SM = 3.5hs\ell^2 \text{ cm}^3$$

$$SM = 0.00185hs\ell^2 \text{ in}^3$$

where

- ℓ = tween deck height or unsupported length, in m (ft)

s and h are as defined in 2/23.3 above.

Both ends of the stiffener webs are to be effectively attached.

23.7 Corrugated Bulkheads

23.7.1 Plating (1 July 2016)

23.7.1(a) Steel Plating. Steel plating is to be not less in thickness than that obtained from the following equation:

$$t = 3s\sqrt{h} \text{ mm}$$

$$t = s\sqrt{h}/50 \text{ in.}$$

where

- t = thickness, in mm (in)
- s = spacing, in m (ft), the greatest of dimensions a , b or c , as indicated in Section 2, Figure 2. The angle ϕ is to be 45 degrees or more.
- h = design head specified by designer, in m (ft)

The ratio of thickness (mm, in) to spacing (m, ft) of corrugated steel bulkheads is to be greater than 22 (0.267), unless a detailed buckling analysis is performed and submitted.

Any steel plating considered effective in the stacking or racking analysis is required to have a minimum thickness of 5.0 mm (0.2 in.).

In no case is the steel plating thickness to be less than 3.0 mm (0.12 in.).

23.7.1(b) *Aluminum Plating.* In the case of aluminum plating, the minimum thicknesses t_{alum} is to be obtained from the following:

$$t_{alum} = t \times \sqrt[3]{\frac{E_{steel}}{E_{aluminum}}}$$

where

- t = minimum required steel plating thickness as defined in the above
- E_{steel} = Young's modulus of elasticity of steel
- $E_{aluminum}$ = Young's modulus of elasticity of aluminum

In the case of corrugated aluminum bulkheads, a detailed buckling analysis is to be performed and submitted.

23.7.2 Stiffeners

The section modulus SM for a corrugated bulkhead is to be not less than that obtained from the following equation:

$$SM = 3.5hs\ell^2 \text{ cm}^3$$

$$SM = 0.00185hs\ell^2 \text{ in}^3$$

where

- ℓ = distance between supporting members, in m (ft)
- s = value determined using $(a + b) + 2c \cos \phi$ (See Section 2, Figure 2)
- h = as defined in 2/23.7.1

The developed section modulus SM may be obtained from the following equations, where a, b, c, d, t, ϕ and z_0 are as indicated in Section 2, Figure 2.

$$A = (a + b)t + 2ct$$

$$z_o = dt(a + c)/A$$

$$I_y = \frac{(a + b)t^3}{12} + ad^2t + \frac{2}{3}cd^2t - Az_0^2$$

$$SM = I_y/z_0 \text{ or } I_y/(d - z_0), \text{ whichever is less}$$

FIGURE 2
Corrugated Bulkhead

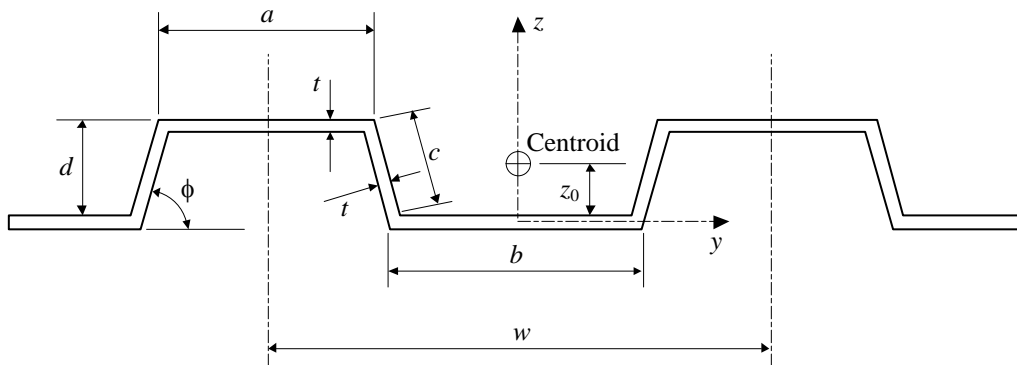

23.7.3 End Connections

The structural arrangements and size of welding at the ends of corrugations are to be designed to develop the required strength of corrugated stiffeners.

23.9 Roof Deck

23.9.1 General

The h used in the design of the roof deck is not to be taken less than $3/4$ the reference h used for bulkhead design or 2.0 m (6.5 ft), whichever is less. In case the reference h for the side and end bulkheads is different, the larger one should be used. If the modules are being designed for a specific location onboard a known vessel or unit, the roof deck may be designed in accordance with the applicable host vessel Rules.

23.9.2 Plating

The plating thickness of the roof deck is not to be less than that obtained from the following equation:

$$t = 3s\sqrt{h} \quad \text{mm}$$

$$t = s\sqrt{h}/50 \quad \text{in.}$$

where

t = thickness, in mm (in)

s = spacing, in m (ft)

h = $3/4$ of the bulkhead design head specified by designer or 2.0 m (6.5 ft), whichever is less, in m (ft)

Any plating considered effective in the stacking or racking analysis is required to have a minimum thickness of 5.0 mm (0.2 in.).

In no case is the plating thickness to be less than 3.0 mm (0.12 in.)

23.9.3 Stiffeners

The section modulus SM for the roof deck stiffeners is to be not less than that obtained from the following equation:

$$SM = 3.5hs\ell^2 \quad \text{cm}^3$$

$$SM = 0.00185hs\ell^2 \quad \text{in}^3$$

where

ℓ = distance between supporting members, in m (ft)

s = spacing, in m (ft)

h = as defined in 23.9.1, in m (ft)

Stiffeners are to be effectively attached at their ends.

23.11 Bottom Deck

The following minimum values of deck loading are to be used in the design of the bottom deck. Where the load from the contents of the module exceeds these values, the deck load, p , used in the calculations is to be adjusted accordingly.

TABLE 3
Minimum Bottom Deck Loading

Bottom Deck	Minimum Deck Loading, p		
	kN/m^2	kgf/m^2	lbf/ft^2
Quarters	4.51	460	94
Public spaces including offices	6.46	659	135
Workshops	9.02	920	188
Storage areas	13	1325	272
Machinery Spaces	18.43	1880	385

23.11.1 Plating (1 July 2016)

23.11.1(a) *Steel Plating.* The steel plating thickness t is not to be less than that obtained from the following equation:

$$t = ks\sqrt{p/\omega} + a \text{ mm (in.)}$$

where

- k = 3.94×10^{-3} (2.18×10^{-3})
- s = spacing of beams, in mm (in.)
- p = intended deck loading in kN/m^2 (kgf/m^2 , lbf/ft^2) but is not to be taken less than the minimum deck loading given in Section 2, Table 3
- ω = 7.04 (718, 44.8)
- a = 1.5 (0.06)

Any steel plating considered effective in the stacking or racking analysis is required to have a minimum thickness of 5.0 mm (0.2 in.).

In no case is the steel plating thickness to be less than 3.0 mm (0.12 in.)

23.11.1(b) *Aluminum Plating.* In the case of aluminum plating, the minimum thicknesses t_{alum} is to be obtained from the following:

$$t_{alum} = t \times \sqrt[3]{\frac{E_{steel}}{E_{aluminum}}}$$

where

- t = minimum required steel plating thickness as defined in the above
- E_{steel} = Young's modulus of elasticity of steel
- $E_{aluminum}$ = Young's modulus of elasticity of aluminum

23.11.2 Stiffeners and Beams

The section modulus SM , in association with the plating to which it is attached, is to be not less than that obtained from the following equation:

$$SM = kcs\ell^2p/\omega \text{ cm}^3 \text{ (in}^3\text{)}$$

where

- k = 7.8 (4.1×10^{-3})
- c = 0.585 for stiffeners effectively connected to deck girders or box beams
- s = spacing of stiffeners or beams, in m (ft)

- ℓ = length of stiffeners, in m (ft); where effective brackets are fitted, the length may be reduced accordingly
- p = intended deck loading in kN/m² (kgf/m², lbf/ft²) but is not to be taken less than the minimum deck loading given in Section 2, Table 3
- ω = 7.04 (718, 44.8)

Stiffeners are to be effectively attached at their ends.

23.13 Deck Girders and Transverses

23.13.1 General

Girders and transverses of the sizes required by 2/23.13.2 through 2/23.13.5 are to be fitted, when necessary, to support the beams. Additional girders are to be fitted, as required, under deck machinery or other heavy concentrated loads. In way of deck girders or special deep beams, the deck plating is to be of sufficient thickness and suitably stiffened to provide an effective part of the girder.

23.13.2 Deck Girders and Transverses

Each deck girder is to have a section modulus SM not less than that obtained from the following equation:

$$SM = 4.74cbh\ell^2 \text{ cm}^3$$

$$SM = 0.0025cbh\ell^2 \text{ in}^3$$

where

- c = 1.0
- b = mean breadth of the area of deck supported, in m (ft)
- h = design head, as required by 2/23.9 or 2/23.11 (p/ω), for the beams supported, in m (ft)
- ℓ = span between centers of supports, in m (ft). Where an effective bracket is fitted, the length ℓ may be modified. See 3-2-6/7.1 of the *Steel Vessel Rules*.

23.13.3 Proportions

Girders and transverses are to have a depth of not less than 0.0583ℓ (0.7 in. per ft of span ℓ), the thickness is not to be less than 1 mm per 100 mm (0.01 in. per in.) of depth plus 4 mm (0.16 in.), but is not to be less than 8.5 mm (0.34 in.) where the face area is 38 cm² (6 in²) or less, 10 mm with 63 cm² (0.40 in. with 10 in²), 12.5 mm with 127 cm² (0.50 in. with 20 in²) and 15 mm with 190 cm² (0.60 in. with 30 in²) or over. The thickness for intermediate area may be obtained by interpolation.

23.13.4 Tripping Brackets

Tripping brackets are to be fitted at intervals not exceeding 3 m (10 ft), near changes of section, and at high concentrated loads. Where the breadth of the flanges on either side of the web exceeds 200 mm (8 in.), tripping brackets are to be arranged to support the flange. Additional supports are to be provided for the flanges where their breadth exceeds 400 mm (16 in.).

23.13.5 End Attachments

The ends of deck girders and transverses are to be effectively attached by welding.

23.15 Sidescuttles and Windows

23.15.1 Sidescuttles

Sidescuttles are defined as being round or oval openings with an area not exceeding 0.16 m² (1.72 ft²). Round or oval openings having areas exceeding 0.16 m² (1.72 ft²) are to be treated as windows.

Sidescuttles are to be of substantial construction in accordance with 2/23.15.2 or a recognized standard.

23.15.2 Window Construction

Window frames are to be metal or other approved material and effectively secured to the adjacent structure. Windows are to have a minimum of a 6.1 mm (1/4-inch) radius at all corners. The glazing is to be set into the frames in a suitable approved packing or compound. Special consideration is to be given to angled house fronts.

The thickness of the window is not to be less than that obtained from *i*), *ii*) or *iii*) below, whichever is greatest.

$$i) \quad t = s \sqrt{\frac{pk}{1000\sigma_a}} \text{ mm} \quad t = s \sqrt{\frac{pk}{\sigma_a}} \text{ in.}$$

$$ii) \quad t = s \sqrt[3]{\frac{pk_1}{20E}} \text{ mm} \quad t = s \sqrt[3]{\frac{pk_1}{0.02E}} \text{ in.}$$

iii) Minimum Tempered Monolithic Glass Thicknesses:

$$t = 9.5 \text{ mm (0.37 in.) for front windows}$$

$$t = 6.5 \text{ mm (0.25 in.) for side and end windows}$$

where

$$t = \text{required window thickness, in mm (in.)}$$

$$s = \text{lesser dimension of window, in m (ft.)}$$

$$h = \text{pressure head, in m (ft), specified by designer}$$

$$p = 9.8h \text{ kN/m}^2 \text{ (0.44h psi)}$$

$$k = \text{factor given in Section 2, Table 4}$$

$$k_1 = \text{factor given in Section 2, Table 4}$$

$$\sigma_a = 0.30\sigma_f$$

$$\sigma_f = \text{material flexural strength; see Section 2, Table 5}$$

$$E = \text{material flexural modulus; see Section 2, Table 5}$$

TABLE 4

ℓ/s	k	k_1
>5	0.750	0.142
5	0.748	0.142
4	0.741	0.140
3	0.713	0.134
2	0.610	0.111
1.8	0.569	0.102
1.6	0.517	0.091
1.4	0.435	0.077
1.2	0.376	0.062
1	0.287	0.044

$$\ell = \text{greater dimension of window panel, in mm (in.)}$$

$$s = \text{lesser dimension of window panel, in mm (in.)}$$

TABLE 5

<i>Glazing</i>	<i>Flexural Strength</i>	<i>Flexural Modulus</i>
Tempered Monolithic	119 MPa (17,200 psi)	73,000 MPa (10,600,000 psi)
Laminated Glass	69 MPa (10,000 psi)	2,620 MPa (380,000 psi)
Polycarbonate*	93 MPa (13,500 psi)	2,345 MPa (340,000 psi)
Acrylic (poly methyl methacrylate)*	110 MPa (16,000 psi)	3,000 MPa (435,000 psi)

* Indicated values are for reference. Aging effects are to be considered for design.

23.17 Doors and Other Closing Appliances (1 June 2018)

Opening and closing appliances are to be framed and stiffened so that the whole structure is equivalent to the unpierced bulkhead when closed. Door plating and stiffeners are to be sized in accordance with 2/23.3 and 2/23.5.

Doors are to be provided with a minimum sill height of 150 mm (6 in.). Ventilation openings are to be provided with a sill height of 900 mm (35.5 in.). Alternatively, the module may be installed elevated above the deck.

Doors on exterior bulkheads are to be of steel or other equivalent material, and are to be provided with gaskets and a minimum of two clamping devices (such as dogs) installed opposite two door hinges. Alternatively, latches may be used in lieu of clamping devices, except for the doors fitted on the unprotected front bulkhead on the lowest tier. In addition to the weather tightness test as required in 3/5, external doors are to be tested for fire integrity ratings, where applicable.

External doors need not be self-closing; however, they are to be fitted with a notice on both sides of the door stating that the doors are to be kept closed. Doors are to be operable from both sides.

23.19 Racking Resistance (1 July 2016)

For modules with bulkheads constructed with a plating thickness below 5 mm ($1/5$ in.), calculations are to be submitted to show that the module is provided with sufficient racking capacity to withstand a load equal to the design $h/2$ distributed over the area of any side bulkhead. $h/2$ is used to account for the difference between maximum pressure and average pressure over a large area. For these calculations, it may be assumed that 50% of the load acts across the top of the module and 50% of the load acts across the bottom of the module. The buckling strength of end bulkheads and stiffeners is to be sufficient for the racking load. Buckling strength of plated structures is to be sufficient when determined in accordance with the *ABS Guide for Buckling and Ultimate Strength Assessment for Offshore Structures*, or another recognized standard acceptable to ABS.

23.21 Stacking of Modules

Where modules are intended to be stacked, details and calculations are to be submitted in accordance with Subsection 4/13.

Dimensions of the corner castings are to be in accordance with the *ABS Guide for Certification of Container Securing Systems*. Alternatives may be considered on a case-by-case basis.

23.23 Materials of Construction

This Guide is intended for modules of welded steel construction. All materials are to be at least ABS Grade A. ASTM A36 steel otherwise tested and certified to the satisfaction of ABS may be used for a thickness up to and including 12.5 mm (0.5 in.) for plates and up to and including 40 mm (1.57 in.) for sections. ASTM A36 is to be manufactured at an ABS-approved steel mill.

If the service temperature is less than -10°C , Charpy tests may be required at the minimum anticipated service temperature. In the absence of Charpy tests, evidence of previous satisfactory service at similar operating temperatures will be considered.

Other non-ABS grades of steel may be applied provided they are at least equivalent to grade A and Charpy tested at or below the intended service temperature.

Corner castings are to be of a suitable material grade to resist brittle fracture at the intended service temperature.

23.25 Aluminum Modules

The use of aluminum alloys will be considered so long as equivalent strength and fire safety are provided subject to approval of the flag Administration. Use of aluminum alloys in hazardous areas is restricted.

23.25.1 Scantling Correction

Where modules are constructed of aluminum alloys, the required plate thickness and stiffener section modulus, SM , are first to be determined as required for steel modules, and are then to be increased by the material factor, Q_0 , as indicated below.

For all deck and bulkhead plating and stiffeners, the required thickness and section modulus for aluminum alloy plate and shapes are obtained from the following equations:

Deck plating:

$$t_{al} = \frac{0.9(Q + \sqrt{Q})}{2} t_s$$

Bulkhead plating:

$$t_{al} = 0.9Q_0 t_s$$

Deck and bulkhead stiffeners:

$$SM_{al} = 0.9Q_0 SM_s$$

where

- t_{al} = minimum thickness of aluminum plate
- t_s = required plate thickness for steel obtained from 2/23.9 for roof decks, 2/23.11 for bottom decks, 2/23.3 for side and end bulkheads, and 2/23.7 for corrugated bulkheads
- SM_{al} = minimum section modulus of aluminum stiffeners
- SM_s = minimum section modulus of steel stiffeners, as determined from 2/23.9 for roof deck stiffeners, 2/23.11 for bottom stiffeners and 2/23.5 for bulkhead stiffeners and 2/23.7 for corrugated bulkheads
- Q = material factor, as determined from 2/23.25.2 below
- Q_0 = material factor, as determined from 2/23.25.2 below

23.25.2 Material Factors

The material factor, Q , is obtained from the following equation:

$$Q = 0.9 + (120/\sigma_y) \quad \text{SI Units}$$

$$Q = 0.9 + (12/\sigma_y) \quad \text{MKS Units}$$

$$Q = 0.9 + (17000/\sigma_y) \quad \text{U.S. Units}$$

but is not to be taken as less than Q_0 below.

The material factor, Q_0 , is obtained from the following equation:

$$Q_0 = 635/(\sigma_y + \sigma_u) \quad \text{SI Units}$$

$$Q_0 = 65/(\sigma_y + \sigma_u) \quad \text{MKS Units}$$

$$Q_0 = 92000/(\sigma_y + \sigma_u) \quad \text{U.S. Units}$$

where

- σ_u = minimum ultimate strength of the welded aluminum alloy under consideration, in N/mm² (kgf/mm², psi), in accordance with the table below
- σ_y = minimum yield strength of the welded aluminum alloy under consideration at 2% offset in a 254 mm (10 in.) gauge length, in N/mm² (kgf/mm², psi), in accordance with the table below

TABLE 6
Minimum Mechanical Properties for Butt-Welded Aluminum Alloys

Alloy	Ultimate Tensile Strength (σ_u) N/mm ² (kgf/mm ² , psi)	Yield Strength (σ_y) ⁽³⁾ N/mm ² (kgf/mm ² , psi)
5083 ⁽¹⁾	275 (28.1, 40000)	125 (12.7, 18000)
5086 ⁽¹⁾	240 (24.6, 35000)	95 (9.85, 14000)
5454 ⁽¹⁾	215 (21.8, 31000)	85 (8.45, 12000)
5456 ⁽¹⁾	290 (29.5, 42000)	130 (13.4, 19000)
6061-T6 ⁽²⁾	165 (16.9, 24000)	105 (10.6, 15000)

Notes:

- 1 For other tempers, refer to 2-5-A1/Table 2 of the *ABS Rules for Materials and Welding (Part 2) – Aluminum and Fiber Reinforced Plastics (FRP)*.
- 2 Values when welded with 4043, 5183, 5356 or 5556 filler wire.
- 3 Yield strength is not required for weld procedure qualification. Values shown apply to the yield strength values of 2/23.25.2.

For other alloys, refer to Table 4 of Section 3 of the Aluminum Association’s Aluminum Construction Manual.

23.25.3 Attachments

Stiffeners on bulkheads are to be attached to the deck plating at their upper and lower ends by welding all around. Cladding metal is to be inserted between aluminum and steel structure. Suitable means are to be taken to avoid direct contact of faying surfaces of aluminum to steel.

25 Protection of Steel

Unless otherwise approved, all steel work is to be suitably coated with paint or an equivalent.

27 ILO Convention

If requested the module may be reviewed to ILO Convention standard(s) for crew accommodation.



SECTION 3 Survey of Module at Fabrication Yard

1 General

This Section outlines the survey requirements to be complied with at the fabrication yard.

3 Documentation

The following documents are to be made available to the Surveyor:

- Approved plans and review letters including any revisions addressing the structural fire protection, electrical, piping and structural aspects of the design and any amendments noted during the technical review to be addressed during the fabrication,
- Maintenance packages for all electrical equipment;
- Welding procedures, welder qualification tests and material certification/traceability;
- Nondestructive Testing (NDT) methods to be used and qualifications of NDT operators, including yard personnel and sub-contractors;
- Extent of NDT examination applied to the project including acceptance criteria to the satisfaction of the attending Surveyor and in accordance with the *ABS Guide for Nondestructive Inspection of Hull Welds*;
- Certificates for items or equipment such as structural fire protection materials, electrical components, etc.

5 Survey Requirements (1 July 2016)

Tightness testing of the module is to be by hose test or equivalent. All exterior windows, doors, sidescuttles, cable penetrations and similar are to be hose-tested after installation.

During installation of deck and bulkhead watertight and fire-rated cable penetrations, the attending Surveyor is to confirm that the installer is familiar with and has access to the manufacturer's installation procedures for stuffing tubes, transit devices or pourable materials.

After installation, all watertight and fire-rated cable penetrations are to be visually examined.

The general alarm, public address, fire detection and alarm and any other safety devices are to be tested and confirmed to be in operating condition. Alarm interfaces are to be examined.

The attending Surveyor is to confirm that the as-built module is in compliance with the approved plans.

7 Marking

For identification purposes, each module is to be permanently marked by the manufacturer with the following information:

- Manufacturer's name and address
- Manufacturer's serial number
- Reference to the ABS approval letter
- Date of manufacture
- Number of persons to be accommodated

- Module weight
- Electrical load of the module
- Design heads of the module (see Subsection 2/23)
- Fire integrity of the exterior boundaries

9 Type Approval

Unit Certification is required for modules approved under the ABS Type Approval Program



SECTION 4 Design Review for Installation Approval

1 General

This Section outlines the technical requirements for the installation of an approved module onboard a host vessel.

Where the additional modules change the service or the tonnage of the vessel (addition of more than 12 special personnel or increase in tonnage to above 500 gross tons), a complete review of the host vessel may be required in consultation with the flag Administration.

3 Submission of Plans

Plans showing the arrangement, details, and interface of the module onboard the host vessel are to be submitted and approved prior to installation of a module onboard a host vessel.

In general, these plans should include the following. Where appropriate, drawings need not be submitted when requirements can be verified by the attending Surveyor:

- i)* A copy of the approval letter(s) for the module. Upon receipt, ABS will perform a review of the specified limits of service. Alternatively, details required by Section 2 are to be submitted.
- ii)* General arrangement plans of the vessel showing the proposed location of the module onboard the vessel. These plans should include:
 - Verification that each of the exterior boundaries of the modules has the appropriate fire rating for the proposed location and orientation.
 - Details of means of escape.
 - Details of the handrails and storm rails.
- iii)* Hazardous area plan showing the host vessel's hazardous areas and the proposed portable module location to allow an assessment to be made of:
 - The distance between portable accommodation air intakes and the hazardous areas
 - The host vessel's approach to ventilation shutdown and gas detection at air intakes
 - The (Ex-type) suitability of battery powered equipment on the exterior of the accommodation with respect to the standard for the host vessel
 - The suitability of the accommodation location in relation to any fire and blast studies that have been conducted.
- iv)* Drawings showing the securing details and arrangements along with supporting calculations. If modules are stacked, full details are to be submitted.
- v)* Drawings showing scantlings and details for the supporting deck structure on which the module is to be installed. Substantiating calculations should also be submitted.
- vi)* Updated fire control plan for the vessel/unit.
- vii)* Details showing the integration with the host vessel's piping, electrical, ventilation, and general alarm/PA system. All piping and electrical connections are to maintain the appropriate structural fire protection and weather-tight integrity at boundary penetrations.

- viii) Details to establish that the installation of the portable module does not reduce the effectiveness of the ESD system of the host vessel, where applicable.
- ix) Host vessel's load analysis to demonstrate that sufficient power is available such that any additional power required by the portable module does not adversely affect the safety of the host vessel
- x) Updated stability information to account for additional weight.

Where ABS is issuing statutory certificates on behalf of the flag Administration, the following is to be submitted:

- xi) Details of additional lifesaving equipment.

5 Arrangement

Modules in which people normally work or live are not to be installed forward of the collision bulkhead. Modules are not to extend beyond the ship sides. Modules may be cantilevered over the bow of an offshore unit. However, the possibility of wave slamming and impact during transit is to be considered.

Modules should generally be elevated from the deck to provide a minimum sill height of 150 mm (6 in.) to doors and 900 mm (35.5 in.) for ventilation openings unless otherwise approved.

Modules intended to be installed adjacent to hazardous areas on MODUs complying with the *ABS MODU Rules 2012* or later or the 2009 IMO MODU Code are to be provided with blast resistance in accordance with 5-1-1/5 of the *ABS MODU Rules, 2012*.

For modules to be installed on offshore production installations, "H-60" ratings are required for the exterior bulkheads that face areas such as wellheads, oil storage tanks, fired vessels (heaters), crude oil processing vessels, and other similar hazards. If such bulkheads are more than 33 m (100 ft) from this source, then this can be relaxed to an "H-0" rating. This may be reduced as outlined in 3-3/5 of the *Facilities Rules*. Modules are not to be located above or below crude oil storage tanks or process areas.

On tankers modules are to be installed in a protected location behind the deckhouse.

7 Stability Requirements

The stability information for the vessel or offshore unit is to be updated to account for the modules.

Stability requirements applicable to the host vessel are to be complied with unless the additional modules change the service or type of vessel.

9 Structures

9.1 General

For modules to be installed on vessels or offshore units, the design head (*h*) is to be calculated for the specific location on the vessel or unit in accordance with this Subsection. The structural design of the module (Section 2) should be approved for a head not less than this head.

9.3 Steel Vessels

For steel vessels over 90 meters in length, the head is to be calculated in accordance with 3-2-11/3.5 of the *Steel Vessel Rules*.

9.5 Steel Cargo Vessels Under 90 Meters

The head is to be calculated in accordance with 3-2-9/3.3 of the *Under 90m Rules*.

9.7 Steel Barges

The head is to be calculated in accordance with 3-2-8/3.1 of the *Barge Rules*.

9.9 MODUs and MOUs

9.9.1 Self-Elevating Drilling Units and Self-Elevating Units

The head is to be calculated in accordance with 3-2-3/15.3 of the *MODU Rules*.

9.9.2 Column-Stabilized Drilling Units and Column-Stabilized Units

Unless adequate wave clearance (3-2-4/9 of the *MODU Rules*) can be demonstrated for all afloat modes of operation, the effect of wave impact is to be taken into account in determining the scantlings of upper structure. See 3-2-4/7 of the *MODU Rules* for the load effects that should be taken into consideration when designing the module.

9.9.3 Surface-Type Drilling Units

The head is to be calculated in accordance with 3-2-11/3.5 of the *Steel Vessel Rules*.

9.11 Floating Production Installations

9.11.1 Ship-Type Installations

The head is to be calculated in accordance with 3-2-11/3.5 of the *Steel Vessel Rules*.

9.11.2 Column-Stabilized Installations

The modules are to have sufficient strength in accordance with 4/9.9.2.

9.11.3 Tension Leg Platforms

The structural design of modules is to be in accordance with 5B-2-3/1.5 of the *ABS Rules for Building and Classing Floating Production Installations (FPI Rules)*.

9.11.4 Spar Installations

The structural design of modules is to be in accordance with 5B-3-3/1.5 of the *FPI Rules*.

9.13 High Speed Craft

The head is to be calculated in accordance with 3-2-2/Table 4 of the *ABS Rules for Building and Classing High Speed Craft (HSC Rules)*.

11 Securing to the Deck

In general, modules are to be permanently welded to deck via steel plates at each corner of the module. Steel plates securing the module to the deck are to be sized in accordance with Subsection 4/13. Means of securing other than welding may be accepted provided the efficiency of the tie downs are design reviewed by ABS. Twist locks may be accepted so long as the loads calculated in accordance with this Subsection 4/13 do not exceed the maximum capacity (SWL) for shear, compression and tension with an additional safety factor of 1.5.

13 Stacking Arrangements

13.1 Loading

13.1.1 General

Where multiple tiers of modules are stacked two or more high, full details and calculations are to be provided. The arrangement is to be designed for the most onerous combination of motions, wind, and green water in accordance with the requirements of the host vessel.

13.1.2 Offshore Units or Installations

For offshore units or installations which use a design wave or site-specific approach, the accelerations used in the stacking analysis are to correspond to the global motions.

13.1.3 Vessels or Barges

Green water pressure is to be combined with the appropriate acceleration loads.

Vessel-specific accelerations corresponding to the vessel class notation (i.e., 25-year North Atlantic for unrestricted service) are to be calculated in accordance with IMO Code of Safe Practice for Cargo Stowage and Securing, *ABS Guide for Certification of Container Securing Systems*, or a seakeeping analysis. If vessel-specific accelerations are not available, the inertial accelerations are to be taken as:

- 1.0g in transverse direction
- 1.0g in vertical direction
- 0.5g in longitudinal direction

where $g = 9.81 \text{ m/s}^2$ (32.2 ft/s²).

Green water pressure may be calculated in accordance with the following:

$$\text{Green water pressure} = 10.05h \text{ kN/m}^2 \text{ (1025}h \text{ kgf/m}^2, 0.4444h \text{ psi)}$$

where h is the head in m (ft) for the specific location onboard the host vessel, see 4/9. $h/2$ is used to account for the difference between the maximum pressure and average pressure over a large area. Wind loads need not be applied to structures subjected to green water.

The maximum transverse and longitudinal loads need not be applied simultaneously; however each is to be combined with the corresponding vertical load. Reference may be made to the IMO Code of Safe Practice for Cargo Stowage and Securing and the *ABS Guide for Certification of Container Securing Systems*.

13.3 Structural Analysis

All load-carrying structure is to be analyzed to resist the loads described in 4/13.1. The analysis is to be performed using recognized calculation methods and is to be fully documented and referenced.

Local stresses are to be combined with primary stresses, where applicable, to determine total stress levels. The possibility of buckling of structural elements is to be considered.

The scantlings of effective structural elements are to be checked on the basis of the allowable stresses specified herein.

13.3.1 Individual Stresses

Individual stress components and, as applicable, direct combinations of such stresses are not to exceed the allowable stress, F , as obtained from the following equation.

$$F = f_y / F.S.$$

where

f_y = specified minimum yield point or yield strength, as defined in Chapter 1 of the *ABS Rules for Materials and Welding (Part 2)*.

$F.S.$ = factor of safety

for static loadings

= 1.67 for axial or bending stress

= 2.50 for shear stress

for combined loadings

= 1.25 for axial or bending stress

= 1.88 for shear stress

13.3.2 Buckling Considerations

Where buckling of a structural element due to compressive or shear stresses, or both, is a consideration, the compressive or shear stress is not to exceed the corresponding allowable stress, F , as obtained from the following equation.

$$F = F_{cr}/F.S.$$

where

F_{cr} = critical compressive or shear buckling stress of the structural element, appropriate to its dimensional configuration, boundary conditions, loading pattern, material, etc.

$F.S.$ = factor of safety
= 1.67 for static loadings
= 1.25 for combined loadings

The buckling strength of plated structures is to be designed according to the latest version of the *ABS Guide for Buckling and Ultimate Strength Assessment for Offshore Structures*, or other recognized standard acceptable to ABS.

13.3.3 Equivalent Stress Criteria for Plated Structures

Plate structures may be designed according to the von Mises equivalent stress criterion, where the von Mises stress is not to exceed $f_y/F.S.$ The factor of safety ($F.S.$) is to be taken as 1.43 for static loading and 1.11 for combined loading.

13.3.4 Details of Structural Connections

Unless connections of structural members are specifically detailed as hinged joints, proper consideration is to be given in the structural analysis to the degree of restraint at such connections. Structural connections are to be detailed in such a manner as to provide full transmission of stresses between members joined, and to minimize stress concentrations.

13.3.5 Securing

Refer to 2/23.23 for material requirements for corner castings. For corner castings and twist locks, the loads calculated in accordance with this section are not to exceed the maximum capacity (SWL) for shear, compression and tension with an additional safety factor of 1.5. Securing gear is to be ABS Type Approved. Twist locks are to be welded in the locked position to prevent inadvertent unlocking. Fully automatic twist locks are not to be used. Other securing gear may be accepted on a case-by-case basis when a factor of safety of 3.0 is applied to the Safe Working Load.

15 Electrical Requirements

15.1 Connection to Host Vessel

When a portable module is being considered for installation on the host vessel, it should be established and documented that sufficient power is available such that any additional power required by the portable module does not adversely affect the safety of the host vessel. Prior to installation, the host vessel's load analysis is to be reviewed and sufficient detail submitted to ABS to demonstrate the same.

The cables that connect the host vessel to the portable module are to be protected against overload and short circuit. The circuit protection is to be coordinated with the host vessel's electrical distribution system such that a failure in the connecting circuit will lead to the disconnection of the portable module without affecting the host vessel's distribution system.

The feeder panel, or connection box, used cable type and size, cable volt drop, circuit breaker types and settings are to be in compliance with the host vessel's class requirements.

Where there is a conflict or inconsistency in design approaches (e.g., hazardous area equipment, earthed vs. unearthed systems, conduit vs. braided cable), the acceptability of the equipment for its host vessel/installation will need to be considered on a case-by-case basis.

The flag State, coastal State Authority or any other jurisdictions which have some responsibility for the host vessel/installation may also need to be satisfied regarding the electrical aspects of the portable equipment installation, such as:

- i)* The host vessel has sufficient power available to meet the needs of the portable equipment without adverse effect on the existing installation with regard to applicable classification requirements.
- ii)* If the portable module needs an emergency source of power from the host vessel, then the power available from the emergency generator/batteries and distribution system is without adverse effect on the existing installation with regard to applicable classification requirements.
- iii)* Overload protective devices are to be coordinated with the host vessel or offshore unit electrical system such that a fault in the electrical system of the portable equipment does not affect the coordinated tripping of the host vessel/installation's system.
- iv)* The electrical interconnection of the portable equipment and the host vessel or offshore unit is to be given adequate electrical protection, mechanical protection and support. Where any interconnecting cables cross fire/escape routes, then they are to be prevented from falling and becoming an obstruction of the route in the event of a fire.
- v)* Arrangements are made to provide electrical continuity between the metallic chassis/frame of the portable equipment and the general metallic structure of the host vessel. The metallic frames of all electrical equipment mounted on the portable equipment and any metallic piping systems are all to be connected to the metallic frame/chassis.

Attention is directed to the proper governmental authority concerning the requirements for general alarm systems.

The portable module fire detection and alarm system is to be capable of being connected to the host vessel's fire-detection panel or to a separate panel adjacent to the fire panel in the host vessel.

15.3 Communications

The effectiveness of the public address (PA) and general alarm (GA) in the portable accommodation depends upon the successful connection of the host vessel installation to that of the portable module and the highest ambient noise levels associated with the vessel's loudest mode of operation. This mode and the associated sound levels should be identified in order to assist in the specification and selection of a suitable portable module.

The integration of the host vessel's and the portable module's communications systems should be addressed prior to the arrival of the portable module on board.

15.5 Combined PA/GA

Where a single system serves as both public address and general alarm, the system is to be arranged such that a single failure within the portable module will not cause the loss of both systems and will minimize the effect of a single failure. Compatibility with the PA/GA system on the host vessel is to be such that a failure in the portable module or on the cables connecting the host vessel to the portable module will not lead to a reduction in the effectiveness of the system on the host vessel.

15.7 External Egress Lighting

New or extended external emergency lighting, controlled from the host vessel, is to be provided to illuminate escape routes to muster and embarkation stations from the exits and stairways of the accommodation module.

15.9 Refrigerated Spaces – Locked-In Alarm

If the portable module has any walk-in refrigerated spaces, then a facility to receive a 'locked-in' alarm signal in a normally manned control position is to be identified on the host vessel. The alarm can be displayed on a separate device supplied with the portable module, or it can be integrated into the host vessel's alarm system. Satisfactory operation of the alarm is to be demonstrated to the satisfaction of the attending Surveyor.

15.11 Fire Detection and Alarm System

The accommodation spaces and service spaces in the portable module are to be covered by an automatic fire detection system. The fire detection system on the host vessel is to be capable of being interfaced with the system on the portable module such that the initiating detector location is capable of being identified on the host vessel's fire detection panel. Alternatively, a display panel that is provided with the portable module and which can be installed close to the host vessel's fire detection display panel will be considered. Operation of the integrated fire detection system is to be demonstrated to the satisfaction of the attending Surveyor.

15.13 Ventilation

Ventilation ducts which are provided to supply air to portable modules and which are run through hazardous areas are to be provided with supply fans at the supply end of the duct in order to provide a positive pressure in the duct in relation to any hazardous areas that the duct may run through or be temporarily subjected to.

Where the host vessel is provided with centralized or automatic means of stopping ventilation, then consideration should be given to extending the system to include the portable modules. Details of the proposed ventilation stop arrangements are to be submitted for review.

If the host vessel is fitted with a means to detect combustible gas at ventilation intakes, then provisions of a similar means should be provided at the intake to portable module. Any automatic actions are to be consistent across the whole of the integrated system.

15.15 Hazardous Areas

15.15.1 Location of Portable Modules with respect to Hazardous Areas

Portable accommodation modules are not to be installed in a hazardous area or have ventilation inlets which are within 3m of a hazardous area.

15.15.2 Cables Running Through Hazardous Areas

All cables installed within the hazardous areas are to be provided with metallic braiding or metallic armoring. A non-metallic impervious sheath is to be applied over the metallic braiding, armoring or sheathing.

Cables are to be protected against mechanical damage. Cables and protective supports are to be so installed as to avoid strain or chafing.

Current-carrying conductors of cables which constitute or are part of an ungrounded distribution system are to be monitored for earth faults in all unearthed conductors.

15.17 Integration with Host Vessel's ESD system

Where the host vessel is provided with an emergency shutdown (ESD) system which allows for equipment to remain energized following an ESD (e.g., PA, emergency lighting, etc.), then the installation of the portable module is not to reduce the effectiveness of the ESD system philosophy. Details, including an explanation, in this regard are to be submitted for review.

17 Piping Requirements

Piping of accommodation modules connected to the host vessel's or unit's piping system is not to affect the safety of the vessel or offshore unit. Nonhazardous drain pipes of accommodation modules are not to be connected to any hazardous drains of the vessel or offshore unit.

19 Fire Fighting Requirements

When installed on the appropriate type vessels or offshore units, fire fighting systems are in general to be in accordance with:

- Part 4, Chapter 7 of the *Steel Vessel Rules*
- Part 4, Chapter 7 of the *OSV Rules*

- Part 4, Chapter 5 of the *Under 90m Rules*
- Part 3, Chapter 5 of the *ABS Rules for Building and Classing Steel Barges (Barge Rules)*
- Part 5 of the *MODU Rules*; or
- Chapter 3, Section 8 and Chapter 4, Section 8 of the *Facilities Rules*

The following documents are to be submitted, where applicable:

- Firefighting equipment
- Fire control plan; in addition to the requirements for fire main systems of the appropriate Rules, the plan is to include an arrangement with the number and position of hydrants such that at least two jets of water not emanating from the same hydrant may reach all onboard modules and any part of the vessel where they are located.

23 Tonnage

Where ABS issues Tonnage Certificates, the effect of the modules is to be considered in accordance with the appropriate conventions to the satisfaction of the Administration.

25 ILO

Where ABS issues International Labor Organization certificates on behalf of the flag Administration, these requirements are to be considered in conjunction with the duration of proposed use onboard the vessel. ILO C133 Article 1.7(b) may be referred to when temporary repair personnel are being carried.

27 Lifesaving Appliances

For any vessel or offshore unit for which ABS issues Safety Certificates on behalf of the flag Administration and all manned barges, an arrangement plan showing additional lifesaving appliances for the additional persons is to be submitted. The applicable ABS, IMO, and Flag State Requirements are to be complied with.

The host unit's lifesaving plan is to be amended to indicate installation and location of additional accommodation modules.

Muster stations are to be provided close to the embarkation stations. Each muster station is to have sufficient clear deck space to accommodate all persons assigned to muster at that station, but at least 0.35 m² per person.

29 Structural Fire Protection

The structural fire protection of the module exterior boundaries is to be appropriate for the location installed onboard the host vessel.

31 Means of Escape and Safe Passage

The module is to be provided with both a main and an emergency means of escape and access for fire fighting and rescue personnel. These means are to be located as far apart from each other as is practicable to allow ready means of escape to the open decks and/or embarkation stations. Exceptionally, one means of escape may be considered, taking into account the nature and location of spaces and the number of persons who might normally be accommodated or employed there.

Gangways or other means for safe passage of the crew from the portable modules are to be provided in accordance with Regulation 25-1 of the International Convention on Load Lines.



SECTION 5 Survey Onboard Host Vessel

1 General

This Section outlines the survey requirements for installation and Annual Survey of an approved module onboard a host vessel.

The documentation listed in Subsections 3/3 and 4/3 is to be provided to the attending Surveyor.

3 Installation Survey Onboard

The purpose of the initial on-board survey of modules is to verify that the installation is in compliance with the ABS-approved plans with particular emphasis on examination of the following, as applicable:

- i) Module orientation on the host vessel or offshore unit; module structural arrangements, supporting foundations, securing details and protective coating.
- ii) Location of modules in relation to any hazardous areas.
- iii) Hook-up and integrity of module piping, electrical, machinery, ventilation system, with gas detection as applicable, including WT penetrations and integration with associated ship systems.
- iv) Fire/Safety Measures such as Fire Control Plan, EEBD's, Lifesaving Appliances, as applicable, Crew Protection, General Alarm/PA, Fire Detection, Portable Extinguishers, number and position of hydrants, Escape Arrangements, Main and Emergency lighting, and any required Emergency Shutdowns.
- v) Compliance with any special requirements from the flag Administration.

5 Annual Surveys for Modules in Service

At each Annual Survey, modules are to be examined for continued use based on the criteria for Initial Survey with particular emphasis on proper Maintenance, Coating Conditions, and no unauthorized modifications.

Where coatings have broken down or corrosion is evident, thickness measurements may be required. The allowable wastage for plating and corrugated bulkheads is 10% and for stiffeners is 25%.

Onboard drills are to incorporate all personnel, including those who are designated to live/work out of the accommodation modules.

7 Survey of Stacking Arrangements

Stacking arrangements are to be installed in accordance with approved plans. The attending Surveyor is to confirm the condition of the corner castings and check the dimensions in accordance with *ABS Rules for Certification of Cargo Containers*. All securing devices are to be ABS Type Approved and visually inspected for damage such as cracking or deformation.



APPENDIX 1 Sample Letter

Project: 1234567
Task #: N/A
Page 1 of 2
XX November 20xx

Attention: XYZ Portable Module Designer

We have your letter of xx October 20xx submitting the following drawings:

G-001	General Arrangement of Module ABC
O-002	Structural fire protection plan
O-003	Joiner work details
O-004	Ventilation plan
E-005	Combined PA/GA
E-006	Fire detection and alarm arrangements.
E-007	Hazardous area protection arrangements – including required alarms
E-008	Booklet of basic electrical details
E-009	Details of batteries
E-010	Cable connection arrangements.
P-011	Piping Arrangement and Details
P-012	Sanitary system details
P-013	Deck drains and scuppers
P-014	Potable water system
F-015	Arrangement of portable extinguishers
F-016	Module Fire control plan
S-016	Construction details
S-017	Door Arrangement and Details
S-018	Portlight arrangement and details
S-016a	Structural Calculations

for our approval.

We have reviewed these drawings in accordance with Section 2 of the *ABS Guide for Portable Accommodation Modules* and find them acceptable subject to the following comments:

- The module has been approved for a design h of 7 m. Therefore, it may be installed in a location onboard a vessel or offshore unit where the bulkhead design h does not exceed this value, please refer to Section 4 of the Guide.
- The exterior boundaries of the module have been found to comply with A-0 requirements.
- The module is not to be installed onboard passenger vessels or special purpose ships required to comply with passenger vessel fire safety requirements.
- As a blast analysis has not been submitted, the module is not to be installed on MODUs adjacent to hazardous areas in accordance with 5-1-1/5 of the *ABS MODU Rules*.

Fabrication of the module is to be witnessed by and found satisfactory to the Surveyor in accordance with Section 3 of the *ABS Guide for Portable Accommodation Modules*. Once completed the module is to be marked with the details listed in Section 3/7 of the subject Guide.

Before installation onboard a host vessel or offshore unit all applicable plans outlined in Section 4 of the *ABS Guide for Portable Accommodation Modules* are to be submitted and approved.

Appendix 1 Sample Letter

Installation onboard a host vessel or offshore unit is to be to the satisfaction of the Surveyor in accordance with Section 5 of the *ABS Guide for Portable Accommodation Modules*.

If you have any questions or if we may be of further assistance please do not hesitate to contact the undersigned at (Telephone number).

Truly yours,

Principal Engineer,
ABS

cc: ABS Survey Office



APPENDIX 2 References

1. ABS, *Rules for Building and Classing Facilities on Offshore Installations*
2. ABS, *Rules for Building and Classing Floating Production Installations*
3. ABS, *Guide for Certification of Container Securing Systems*
4. ABS, *Rules for Building and Classing Mobile Offshore Drilling Units*
5. ABS, *Rules for Building and Classing Offshore Installations*
6. ABS, *Rules for Building and Classing Steel Barges*
7. ABS, *Rules for Building and Classing Steel Vessels*
8. ABS, *Rules for Building and Classing Steel Vessels Under 90 Meters (295 Feet) in Length*
9. ABS, *Rules for Building and Classing Offshore Support Vessels*
10. ABS, *Guide for Nondestructive Inspection of Hull Welds*
11. Aluminum Association, *Aluminum Construction Manual*
12. IMO, Code of Safe Practice for Cargo Stowage and Securing, Resolution A.714(17)
13. IMO, Fire Test Procedures (FTP) Code, MSC Resolution 307(88)
14. IMO, International Convention for the Safety of Life at Sea (SOLAS), 1974 as amended
15. IMO, Code for the Construction and Equipment of Mobile Offshore Drilling Units (MODU), 2009, Resolution A.1023(26)
16. ISO, ISO 1716, Reaction to Fire Tests for Building and Transport Products – Determination of the Heat of Combustion