

Requirements for

Direct Current (DC) Power Distribution Systems for Marine and Offshore Applications



July 2022



REQUIREMENTS FOR

**DIRECT CURRENT (DC) POWER DISTRIBUTION
SYSTEMS FOR MARINE AND OFFSHORE APPLICATIONS
JULY 2022**

American Bureau of Shipping
Incorporated by Act of Legislature of
the State of New York 1862

© 2022 American Bureau of Shipping. All rights reserved.
ABS Plaza
1701 City Plaza Drive
Spring, TX 77389 USA

Foreword (1 July 2022)

This document has been developed to provide guidance for the design, installation, testing and survey of Direct Current (DC) power distribution systems for marine and offshore applications. It is intended to establish safety guidelines for owners, operators, shipyards, designers, manufacturers and integrators. For requirements applicable to conventional AC systems (such as AC generator protection, AC subsystem harmonic distortions and frequency variations), see Part 4, Chapter 8 of the *ABS Rules for Building and Classing Marine Vessels* and Part 4, Chapter 3 of the *ABS Rules for Building and Classing Mobile Offshore Units*.

The installation of power electronic conversion equipment and DC consumers as well as the use of energy storage systems (ESS) and renewable energy is increasing in the marine and offshore industries. ABS recognizes the application of DC distribution technology in support of the electric propulsion and the integration of generators, ESS and DC loads. DC distribution systems are independent from a fixed frequency and such non-frequency-related DC systems offer the opportunity for more efficient operations. This can include varying generator speed and voltage according to the demands of vessel services and propulsion loads. The DC distribution arrangement has benefits such as flexible equipment arrangement, increased fuel efficiency, low vibration noise, and reduced electrical equipment size and weight.

Although there exist recommended practices and guidelines which address the subject, specific industry standards for comprehensive shipboard DC systems are few. In addition, various integrators and vendors are currently implementing and using different design concepts and technologies for the integration of electrical components into DC power distribution systems. This document addresses the general safety aspects of system design, DC system components, testing and survey, and risk assessment.

The July 2022 version changes the document type from “Guide” to “Requirements”. “Requirements” documents contain mandatory criteria for Classification and issuance of Class Certificates, while Guides contain only requirements for optional Notations (see 1-1-4/1.5 of the *ABS Rules for Conditions of Classification (Part 1)*). The title is changed from "*Guide for Direct Current (DC) Power Distribution Systems for Marine and Offshore Applications*" to "*Requirements for Direct Current (DC) Power Distribution Systems for Marine and Offshore Applications*". Accordingly, editorial changes are made throughout this document.

This document becomes effective on the first day of the month of publication.

Users are advised to check periodically on the ABS website www.eagle.org to verify that this version is the most current.

We welcome your feedback. Comments or suggestions can be sent electronically by email to rsd@eagle.org.



REQUIREMENTS FOR

DIRECT CURRENT (DC) POWER DISTRIBUTION SYSTEMS FOR MARINE AND OFFSHORE APPLICATIONS

CONTENTS

SECTION 1	General.....	5
1	Introduction.....	5
3	Scope.....	5
5	Application.....	6
7	Terminology.....	6
9	Abbreviations and Acronyms.....	7
11	References.....	8
	11.1 ABS.....	8
	11.3 Industry Standards.....	8
	FIGURE 1 Example of a DC Power Distribution System.....	6
SECTION 2	Plans and Data to be Submitted.....	9
1	Risk Assessments.....	9
3	Functional Descriptions and Technical Details.....	9
5	System Plans.....	9
7	Equipment Installation Arrangements.....	9
9	Onboard Documents.....	10
SECTION 3	System Design Requirements.....	11
1	General.....	11
	1.1 Functionality.....	11
	1.3 Voltage Variations.....	11
	1.5 Power Quality.....	11
	1.7 Earthing.....	12
	1.9 Computer-Based Systems.....	12
	1.11 Materials.....	12
	1.13 Clearance and Creepage Distances.....	12
	1.15 Enclosures.....	12
3	Electrical Power Sources.....	12

5	Energy Storage Systems (ESS).....	13
7	External or Shore Power Supply Connection.....	14
9	Power Distribution.....	14
9.1	Isolation and Disconnection Means.....	14
9.3	DC Bus.....	14
11	Power Electronic Converters (PEC).....	15
13	Power Management System (PMS).....	15
15	Protection Coordination and Selectivity.....	16
15.1	General.....	16
15.3	Short-Circuit Currents and Fault Conditions within DC Systems.....	16
15.5	Selective Protection Strategy.....	16
17	Risk Assessment.....	20
TABLE 1	Voltage Variations for DC Distribution Systems.....	11
FIGURE 1	Example of a DC Power Distribution System Block Diagram Concept.....	13
FIGURE 2	Short Circuit Fault Location 1 – Upstream of DC Bus (example schematic for reference only).....	18
FIGURE 3	Short Circuit Fault location 2 – On DC Bus (example schematic for reference only).....	19
FIGURE 4	Short Circuit Fault Location 3 – Downstream of DC Bus (example schematic for reference only).....	20
SECTION 4	Installation, Testing, and Trials.....	22
1	General.....	22
3	Testing and Trial Documents to be Submitted.....	22
5	Inspection and Testing.....	22
7	Sea Trials.....	23
SECTION 5	Surveys.....	24
1	General.....	24
3	Surveys during Construction.....	24
5	Surveys after Construction.....	24
5.1	General.....	24
5.3	Special Periodical Surveys.....	24

1 Introduction

ABS recognizes the application of DC distribution technology in the marine and offshore industries and its benefits for improving system arrangement flexibility and energy efficiency. This document has been developed to facilitate the effective integration of DC distribution equipment into onboard electrical systems.

Such DC power distribution systems distribute DC power from electrical sources to various vessel services and propulsion loads through a DC bus architecture along with power electronic converters. This distribution setup is used in lieu of a traditional AC main switchboard and transformers.

Although there are some similarities between traditional AC power distribution systems and DC power distribution systems, they have different protection and control philosophies. The AC system requirements should not be applied to DC distribution systems directly. This document provides supplemental requirements to the DC electrical systems currently included in the *ABS Rules for Building and Classing Marine Vessels (Marine Vessel Rules)* and the *ABS Rules for Building and Classing Mobile Offshore Units (MOU Rules)*.

Since there could be interconnections between AC systems and DC distribution systems, the applicable AC system requirements in Part 4, Chapter 8 of the *Marine Vessel Rules* and Part 4, Chapter 3 of the *MOU Rules* are still to be complied with as appropriate.

3 Scope

This document provides the requirements of specific safety aspects associated with the use of shipboard direct-current (DC) power distribution systems.

This document is to be used in conjunction with and as a supplement to Part 4 of the *Marine Vessel Rules* and the *MOU Rules*, or other ABS Rules as applicable.

For vessels certified to the 1974 SOLAS Convention, as amended, items shown as “other approved means” are subject to the vessel flag State Administration approval, as applicable.

This document covers the DC power distribution systems on board vessels with low voltage DC (LVDC) up to 1500 V.

The following Sections of this document are intended to address the fundamental and general safety aspects of system design, DC system components, testing and survey, and risk.

5 Application

This document is applies to marine and offshore assets designed, constructed, or retrofitted with a DC power distribution system, where electrical power sources, vessel major loads, and/or energy storage systems are connected to the DC bus directly or via power electronic converters.

The optional notation **LVDC-DIST** may be granted to those assets that meet the requirements of this document.

When ABS Type Approval for DC distribution system equipment is requested, applicants should contact ABS for the approval process. For ABS Type Approval Program requirements, please refer to the *ABS Rules for Conditions of Classification (Part 1)*. Alternative certification schemes are also available as documented in 1-1-A3/5.5 of the *ABS Rules for Conditions of Classification (Part 1)*.

7 Terminology

Low Voltage DC (LVDC). Low voltage DC in this document refers to voltages up to and including 1500 V DC.

DC Power Distribution System. An onboard electrical power distribution system, where electrical power sources, vessel loads, and/or energy storage systems are connected to the DC bus directly or via power electronic converters. See Section 1, Figure 1 for an example of a DC Power Distribution system.

FIGURE 1
Example of a DC Power Distribution System

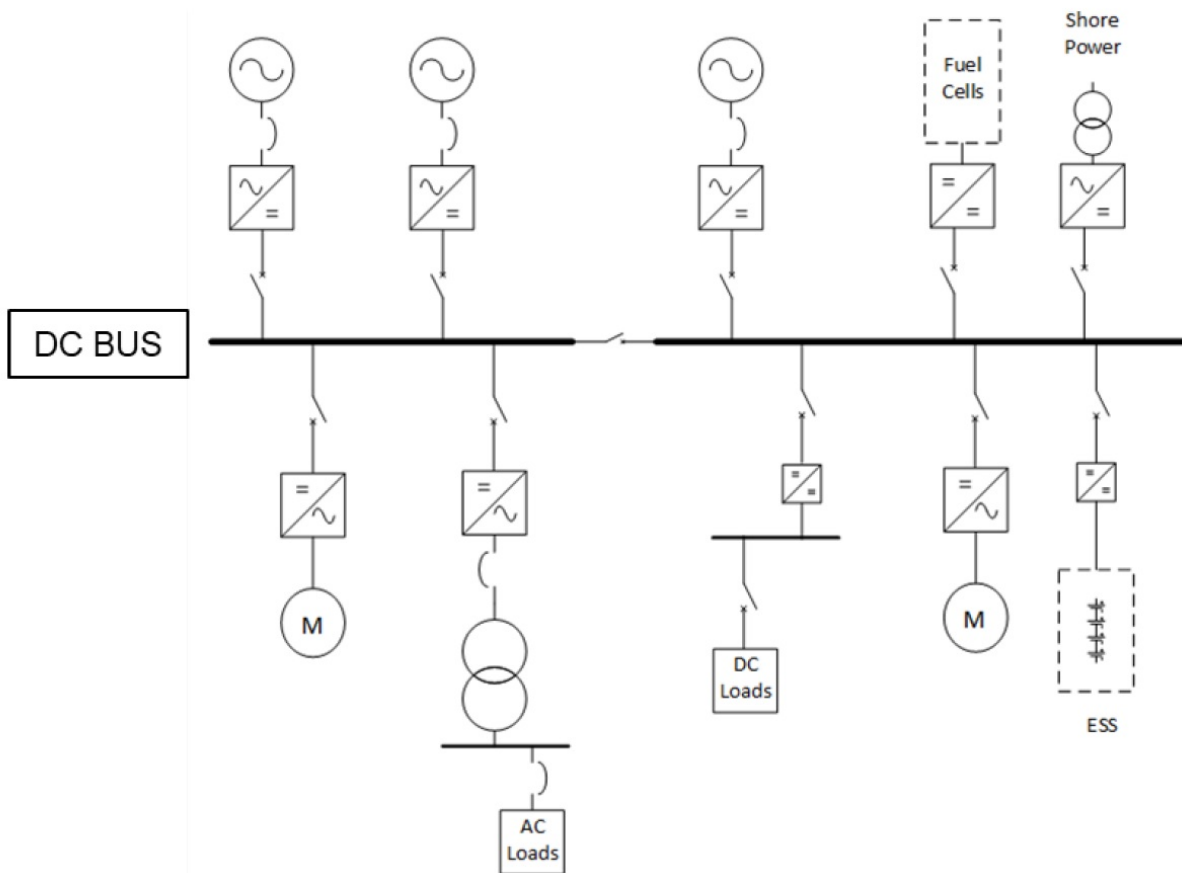

Note: Fuel Cells will be considered as energy storage systems if it is provided with bi-directional power flow arrangements (which also allow the generation of fuel from electricity), otherwise fuel cells will be considered as electrical power sources.

Electronic Power Conversion. Change of one or more of the characteristics of an electric power system essentially without appreciable loss of power by means of electronic valve devices. (Clause 3.1.15 of IEC 60146-1-1:2009)

Power Electronic Converter (PEC). An operative unit for electronic power conversion, comprising one or more electronic valve devices, and auxiliaries if any. (Clause 3.1.16 of IEC 60146-1-1:2009)

Notes:

The following are examples of power electronic converter types typically used in DC power distribution systems:

- AC to DC rectifiers between AC generators/AC shore power and the DC bus
- DC to AC inverters between the DC bus and AC motor loads/AC subsystems
- DC to DC converters between DC bus and DC loads/DC subsystems
- DC to DC bi-directional converters between Energy Storage Systems (ESS)/Fuel Cells and the DC bus

Semiconductor Converter. An electronic power converter with semiconductor valve devices. (Clause 3.1.19 of IEC 60146-1-1:2009)

9 Abbreviations and Acronyms

The following abbreviations and acronyms are applied to the terms used in this document:

AC: Alternating Current

AC/DC: Alternating Current to Direct Current Conversion

DC: Direct Current

DC/AC: Direct Current to Alternating Current Conversion

DC/DC: Direct Current to Direct Current Conversion

DP: Dynamic Positioning

ESS: Energy Storage Systems

FAT: Factory Acceptance Test

FMEA: Failure Modes and Effects Analysis

IEC: International Electrotechnical Commission

IEEE: Institute of Electrical and Electronics Engineers

IEP: Integrated Electric Propulsion

IGBT: Insulated Gate Bipolar Transistor

LVDC: Low Voltage Direct Current

LVDC-DIST: Low Voltage Direct Current - Distribution

PEC: Power Electronic Converters

PMS: Power Management System

THD: Total Harmonic Distortion

11 References

11.1 ABS

ABS Rules for Building and Classing Marine Vessels (Marine Vessel Rules)

ABS Rules for Building and Classing Mobile Offshore Units (MOU Rules)

ABS Requirements for Use of Lithium-ion Batteries in the Marine and Offshore Industries (Lithium-ion Battery Requirements)

ABS Requirements for Use of Supercapacitors in the Marine and Offshore Industries (Supercapacitor Requirements)

ABS Guide for Dynamic Positioning Systems (DPS Guide)

ABS Guidance Notes on Risk Assessment Application for the Marine and Offshore Industries

ABS Guidance Notes on Failure Mode and Effects Analysis (FMEA) for Classification

ABS Advisory on Hybrid Electric Power Systems

11.3 Industry Standards

IEC 61557 Electrical safety in low voltage distribution systems up to 1000 V AC and 1500 V DC. - Equipment for testing, measuring or monitoring of protective measures

IEC 60664 Insulation coordination for equipment within low-voltage systems

IEC 61439 Low-voltage switchgear and controlgear assemblies

IEC 60092 Electrical installation in ships

IEC 62447 Safety requirements for power electronic converter systems and equipment

IEC 60146 Semiconductor converters - General requirements and line commutated converters

IEC 61660 Short-circuit currents in d.c. auxiliary installations in power plants and substations

IEC 60364-4-44 Low-voltage electrical installations - Part 4-44: Protection for safety - Protection against voltage disturbances and electromagnetic disturbances

IEC 61800 Adjustable speed electrical power drive systems

IEC PAS 63108: 2017 Electrical installations in ships - Primary DC Distribution - System design architecture

IEEE 45 Recommended Practice for Electrical Installations on Shipboard

IEEE C37.23 Standard for Metal-Enclosed Bus

IEEE 946 Recommended Practice for the Design of DC Auxiliary Power Systems for Generating Systems

IEEE Std. 1662-2008 Guide for the design and application of Power Electronics in Electrical Power Systems on Ships

IEEE Std. 1709-2010 Recommended Practice for 1 to 35 KV Medium Voltage DC Power Systems on Ships

NFPA 70 National Electric Code (NEC)

SECTION 2 Plans and Data to be Submitted

In addition to the applicable information mentioned in 4–8–1/5 of the *Marine Vessel Rules*, the following documents are to be submitted as a minimum.

1 Risk Assessments

Risk Assessment Reports (e.g., Failure Modes and Effects Analysis)

3 Functional Descriptions and Technical Details

- i) General system description
- ii) DC bus ducts/bus bar technical details
- iii) Functional description of Energy Storage Systems (ESS) as applicable
- iv) Functional description of Power Management Systems (PMS), including equipment fitted with preferential trips, schedule of sequential start of motors, etc., as applicable.
- v) Functional description and technical specifications of protective devices (e.g., circuit breakers, fuses, disconnectors/switches, etc.)
- vi) Functional description and technical specifications of power electronic converters (e.g., generator rectifiers, AC ship loads inverters, propulsion thruster drives, battery chargers, etc.)

5 System Plans

- i) System One-line Diagram
- ii) Load Analysis
- iii) Short-Circuit Data (including the maximum calculated short-circuit current values at the main DC buses, and protective device ratings)
- iv) Protective Device Coordination Study
- v) Voltage-drop Calculations
- vi) Inspection Procedure

7 Equipment Installation Arrangements

- i) General arrangement plans, including equipment physical dimensions and equipment locations
- ii) Insulation and earthing system arrangement plans
- iii) DC cable/bus-duct wiring diagrams and wiring practices (as defined in Booklet of Standard Wiring Practice in 4-8-1/5.3.1 of the *Marine Vessel Rules*, as applicable)

9 Onboard Documents

Operation and maintenance manuals are to be provided on board and submitted for information upon request by ABS. The manuals are to include:

- i)* A description of the systems or Basis of Design (BoD)
- ii)* Operating instructions for the equipment and systems
- iii)* Software configuration procedures (e.g., version updating, function testing)
- iv)* Maintenance and replacement instructions and schedules (e.g., energy storage devices)

SECTION 3 System Design Requirements

1 General

1.1 Functionality

- i) The DC power distribution system is to distribute sufficient power to the intended loads of the vessel during all operational modes (i.e., normal sea going, cargo handling, harbor maneuver and emergency operations.).
- ii) The DC power distribution system is to provide appropriate protection for the electrical equipment and personnel who operate the equipment during normal operation, maintenance and fault conditions.

1.3 Voltage Variations

The design is to comply with the requirements for Voltage Variations for DC Distribution Systems as per 4-8-3/1.9 of the *Marine Vessel Rules*. The applicable table is listed below for convenience.

TABLE 1
Voltage Variations for DC Distribution Systems

<i>Voltage Variations for DC Distribution Systems (such as systems supplied by DC generators or rectifiers)</i>	
<i>Parameters</i>	<i>Variations</i>
Voltage tolerance (continuous)	±10%
Voltage cyclic variation deviation	5%
Voltage ripple (AC rms over steady DC voltage)	10%

Note: See also IEC 60092-101

1.5 Power Quality

- i) Any harmonics created within AC systems is to be within the limits specified in 4-8-2/7.21 of the *Marine Vessel Rules*.
- ii) Considerations are to be taken when ripple currents flow between the DC power sources and connected loads. Also, voltage ripples and noise developed from the converters (e.g., generator rectifier, AC load inverter) are to be mitigated so that they do not impact the normal system operation. See details in Section 3, Table 1 of this document.

- iii) A means of monitoring power quality is to be provided to measure, record, and report the above conditions and any other power disturbances (e.g., spikes, sags, surge, etc.). See also 3/15.3.3 of this document.

1.7 Earthing

- i) When the DC distribution system is ungrounded, means of detection of the system insulation condition is to be provided. Those means of detection are to be rated for the system voltage.
- ii) A means for insulation monitoring and alarm is to be provided in accordance with 4-8-3/Table 5 (item 3) of the *Marine Vessel Rules* for the purpose of detecting earth faults.

1.9 Computer-Based Systems

The computer-based systems controlling the DC power distribution system and associated protection systems are to comply with requirements in Section 4-9-3 of the *Marine Vessel Rules*.

1.11 Materials

The electrical equipment is to be constructed in accordance with 4-8-3/1.7 in the *Marine Vessel Rules*.

1.13 Clearance and Creepage Distances

The equipment is to be designed and manufactured with electrical clearance and creepage distances for the rated voltage in order to prevent electrical failure or insulation breakdowns. The equipment is to comply with the applicable sections of IEC 61439-1 or other recognized standards.

1.15 Enclosures

Electrical equipment is to have a degree of enclosure for protection against the intrusion of foreign objects and liquids, appropriate for the location in which it is installed as required in 4-8-3/1.11 of the *Marine Vessel Rules*.

3 Electrical Power Sources

The electrical power sources of the DC power distribution system are to be described in the system specifications, including but not limited to generators, fuel cells, and other renewable sources if applicable. The electric power sources are to be connected to the DC bus directly or through power electronic converters (such as AC/DC rectifiers, DC/DC converters). The electrical power sources are to be protected against faults with protective devices such as DC circuit breakers, fault current limiting/bypass converters, solid state switches and fuses, or a combination of the same.

Section 3, Figure 1 below shows the general system block diagram of a low voltage DC power distribution system.

FIGURE 1
Example of a DC Power Distribution System Block Diagram Concept

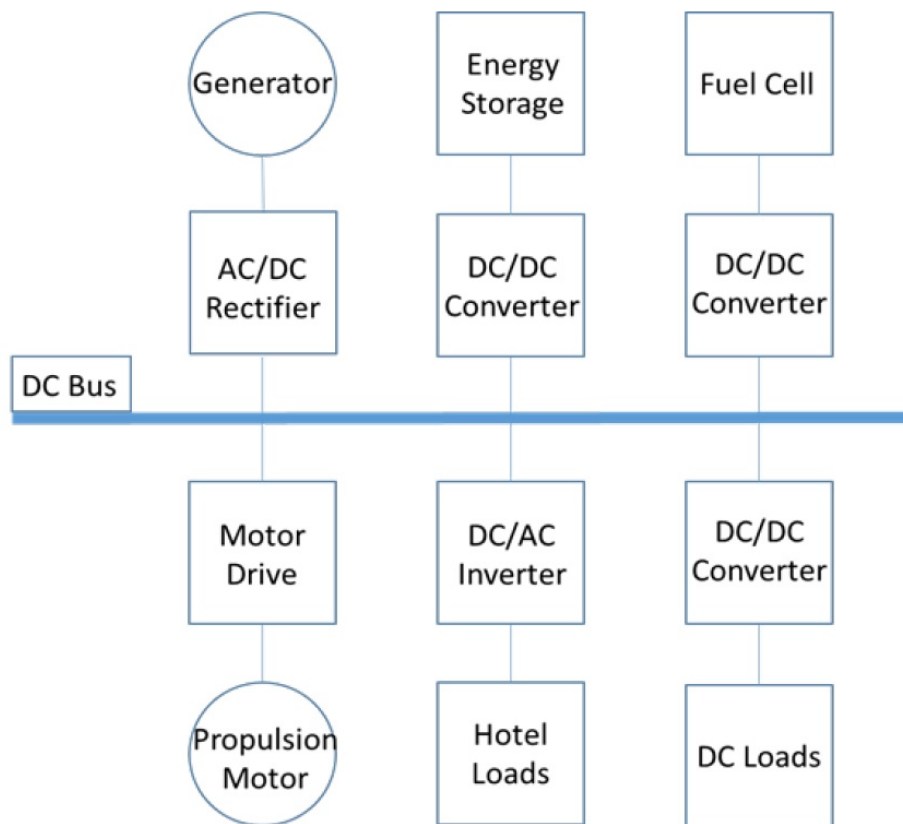

5 Energy Storage Systems (ESS)

If Energy Storage Systems are installed in the onboard DC power distribution system, the following requirements are to be followed:

- i)* Any ESS (such as batteries, supercapacitors, flywheels, etc.) discharged to and charged by the DC bus is to be protected against electrical faults (including short circuit currents) in the system.
- ii)* Any ESS, which is discharged to and charged by the DC bus, is to be provided with means of isolation for maintenance purposes.
- iii)* Any internal fault in an ESS is not to affect the rest of the system.
- iv)* Single failure of an ESS, when it serves as one of the primary power sources, is not to result in total loss of vessel normal operation capability (including DP functions as applicable).
- v)* Lithium-ion batteries installed in DC distribution systems are to be in accordance with the *ABS Requirements for Use of Lithium-ion Batteries in the Marine and Offshore Industries*.
- vi)* Conventional batteries (e.g., lead acid, alkaline types) installed in DC distribution systems are to be in accordance with the *Marine Vessel Rules* and the *MOU Rules*.
- vii)* Supercapacitors installed in DC distribution systems are to be in accordance with the *ABS Requirements for Use of Supercapacitors in the Marine and Offshore Industries*.

7 External or Shore Power Supply Connection

Where arrangements are made for the supply of electricity from a source on shore or other external source, the requirements in 4-8-2/11.1 in the *Marine Vessel Rules* and/or 4-3-2/7.7 in the *MOU Rules* are to be complied with as applicable. In addition, the following requirements are to be followed as applicable.

- i) The type of shore supply (AC or DC) is to be considered in the design of the shore connection. Thus, converters and/or associated transformers are to be provided for external power supply as applicable.
- ii) Associated protective and isolation devices for shore power are to be provided. These devices are to be considered in the vessel protection and coordination study.

9 Power Distribution

9.1 Isolation and Disconnection Means

- i) Where the main source of electrical power is necessary for propulsion of the vessel, the main DC bus is to be subdivided into at least two sections, which are to be connected by DC circuit breakers or other approved means.
- ii) The rating of any disconnecting devices (other than bus-tie disconnecting means) is to be equal to or higher than the voltage and current ratings of connected load. Such device is to have an indicator for its open or closed position. The bus bar connections are to comply with the requirements in 4-8-3/5.5.1 of the *Marine Vessel Rules*.
- iii) Appropriate operational measures or interlocks are to be provided to prevent access to energized circuits during maintenance, except when a risk assessment shows such a condition is safe for the operator.
- iv) Identification plates for feeders and branch circuits are to be provided and are to indicate the circuit designation and the rating or settings of the fuse or circuit breaker of the circuit.

9.3 DC Bus

9.3.1 General

The DC bus is to be sized and arranged such that the temperature rise will not affect the normal operation of electrical devices connected to it. The DC bus is to be sized based on the combined rated output current from the converters supplied by each power source (this includes generators, fuel cells, and ESS, as applicable). Alternative bus sizing methods may be considered.

The DC bus is to be properly sized to withstand the short circuit current available on the DC bus.

Note: The DC distribution system design may possess additional protective circuits that will block the current contributions of the inverter modules and downstream AC loads in the event of a short circuit at the DC bus. If such additional protective circuits are provided, the details of the operation of such a protective circuit needs to be considered when calculating the short-circuit rating of the DC bus.

9.3.2 Bus Ducts

If bus ducts are used to distribute and control electrical energy throughout the vessel, the bus ducts are to be designed, constructed, and installed in accordance with IEC 61439-6 or IEEE C37.23 or other recognized standard.

9.3.3 Cables

Where cables are used in lieu of bus ducts, cables are to be designed, constructed, and installed in accordance with 4-8-2/7.7, 4-8-3/9, and 4-8-4/21 of the *Marine Vessel Rules*, as applicable. Other recognized standards may also be acceptable.

9.3.4 Protective Devices

The DC bus is to incorporate protective devices against fault conditions (e.g., short circuit, overcurrent).

9.3.5 DC Bus Protection Coordination

The bus protection function settings are to be coordinated with other protection function settings.

9.3.6 Overload Protection

Circuit breaker, fuses, switches, and power electronic converters used for overload protection are to be provided for the specific application (e.g. motor circuit, lighting circuit, distribution board circuit, etc.) in accordance with 4-8-2/9.5 of the *Marine Vessel Rules*, IEC 60092-202 and IEC 61892-2 as applicable.

11 Power Electronic Converters (PEC)

In addition to the applicable requirements of semiconductor converters in the 4-8-3/8 of the *Marine Vessel Rules*, power electronic converters (AC/DC, DC/AC, DC/DC conversions) for DC power distribution system are to comply with the following requirements.

- i) The design of the converter is to be in accordance with a recognized standard (e.g., IEC standards 60146 and 62477)
- ii) Each power electronic converter is to be provided with the status indication that includes but is not limited to: power input and power output, temperature, and overload. Additional functions, such as alarms and shutdowns, may be necessary as determined in the risk assessment process.
- iii) Converter control software is to comply with Computer-based Systems requirements as per Section 4-9-3 of the *Marine Vessel Rules*.
- iv) Power electronic converters are to be designed to withstand foreseeable abnormal conditions (e.g., transient overvoltage and overcurrent) from the DC bus without changes in their characteristics and functionalities.
- v) The short-circuit contributions of internal capacitors in converters are to be considered in the sizing of protective devices and in the system protection coordination study.
- vi) The pre-charging of the converter internal capacitor before connecting the load to the energized DC bus, and the recharging of the converter internal capacitors during and after short circuit is to be managed to mitigate the risk of damage to converter components caused by transient currents.
- vii) For vessel with an integrated electrical propulsion systems, generator converters (such as AC generator rectifiers) operating in parallel are to be able to conduct load sharing under the control of a Power Management System. Other means of control for load sharing may be accepted provided that overload of generators is prevented.
- viii) Where converters are arranged to provide protection against electrical faults, a disconnecting method is to be provided to isolate the converter from its source. In case of any converter's internal failure, a backup protection method is to be provided. In such arrangement, the design is to demonstrate that the converter will operate within the safe operational specification under normal and fault conditions.
- ix) Design of the cooling system for power electronic converters is to comply with 4-8-3/8.5.8 of the *Marine Vessel Rules*.

13 Power Management System (PMS)

A power management system (PMS) is required to be installed onboard for vessels having notations such as **DPS**, **ACCU**, etc., as indicated in the *Marine Vessel Rules* and the *MOU Rules*, and the *ABS Guide for Dynamic Positioning Systems*.

Consideration is to be given to the installation of a PMS on board to provide monitoring, control and protection functions to maintain sufficient electrical power available on various operation modes.

15 Protection Coordination and Selectivity

15.1 General

- i)* In general, the DC system protection is to be accomplished by the use of DC circuit breakers, fuses, converter controls, solid state switches, and other technologies that achieve selectivity and appropriate protection coordination of such DC power systems.
- ii)* The protection system of the DC distribution system is to be able to detect and locate the fault, and isolate the faulted equipment or subsystems from the rest of the DC system.
- iii)* The design of the protection system is to demonstrate that the protective device nearest to the fault will open first and thereby isolate the faulted portion from the rest of the system.

15.3 Short-Circuit Currents and Fault Conditions within DC Systems

15.3.1 Consideration of Fault Current Contributions

In general, the contributions of short-circuit current on the DC bus are from:

- i)* Generators (e.g., through the rectifier modules)
- ii)* Converters (e.g., from the internal capacitors within the inverter modules)
- iii)* AC motor loads (e.g., fed through the inverter modules)
- iv)* DC loads (e.g., fed through the converter modules)
- v)* Downstream AC sub-distribution boards
- vi)* Energy storage systems (batteries, supercapacitors, flywheels, etc., if installed)
- vii)* The healthy side of the DC bus segments before interruption by the DC bus-tie breaker (e.g., in cases where the DC bus is operated in a closed-ring mode).

15.3.2 Short Circuit Calculation

In order to properly size protective devices and equipment connected to the DC bus, short circuit current calculations are to be conducted.

Due to different converter configurations used in the DC distribution system, methods of calculation are to be based on steady state and transient state as needed. Application of standards (e.g., IEC 61660, IEEE 946) and/or other modeling and simulation approaches are to be documented.

15.3.3 Transient Overvoltage

Fault types or switching operations and their locations within the DC systems may lead to other events such as the development of overvoltage or transient voltages. Therefore, overvoltage transient studies are recommended in order to assess and protect the entire electrical systems from those risks. The method and analysis utilized for transient overvoltage protection is to be submitted for ABS review. Refer to IEC 60364-4-44 for specific requirements of protection against transient overvoltage.

15.5 Selective Protection Strategy

15.5.1 General

- i)* The requirements to provide a selective protection strategy is to minimize equipment damage and power disruption of the DC power distribution system. Selectivity can be achieved through the integration of different protective devices and the use of software within sections or zones of the electrical network. See 3/15.5.2 through 3/15.5.4 below.

- ii)* Other strategies or approaches to demonstrate a selective protection scheme are also acceptable to ABS provided that appropriate documentation is submitted for review.

15.5.2 Protection within Zone Upstream of DC Bus

For fault conditions within this electrical network area, the following as a minimum is to be considered:

- i)* Fault current detection functionalities are to be provided within a generator protection unit and/or within the generator converter as applicable.
- ii)* Protective devices between the DC bus and the electrical power sources are to be properly sized and set up to trip and isolate the fault.
- iii)* In an event of fault in the generator, the failed generator is to be de-excited.
- iv)* The Power Management System is to reduce load in order to prevent blackout caused by overloading the remaining running generators.
- v)* The power electronic converter on the power generation side is to prevent reverse power flow from the DC bus to the generators.
- vi)* Where converters are utilized to protect the electrical power sources, a back-up short circuit protection method is to be provided in case of an internal fault in the power electronic converter (such as AC/DC rectifier modules) between each single generator and the DC bus. As an alternative to a backup method, the designer is to demonstrate the same level of protection in their design by submitting a description of how this is achieved.

FIGURE 2
Short Circuit Fault Location 1 – Upstream of DC Bus
(example schematic for reference only)

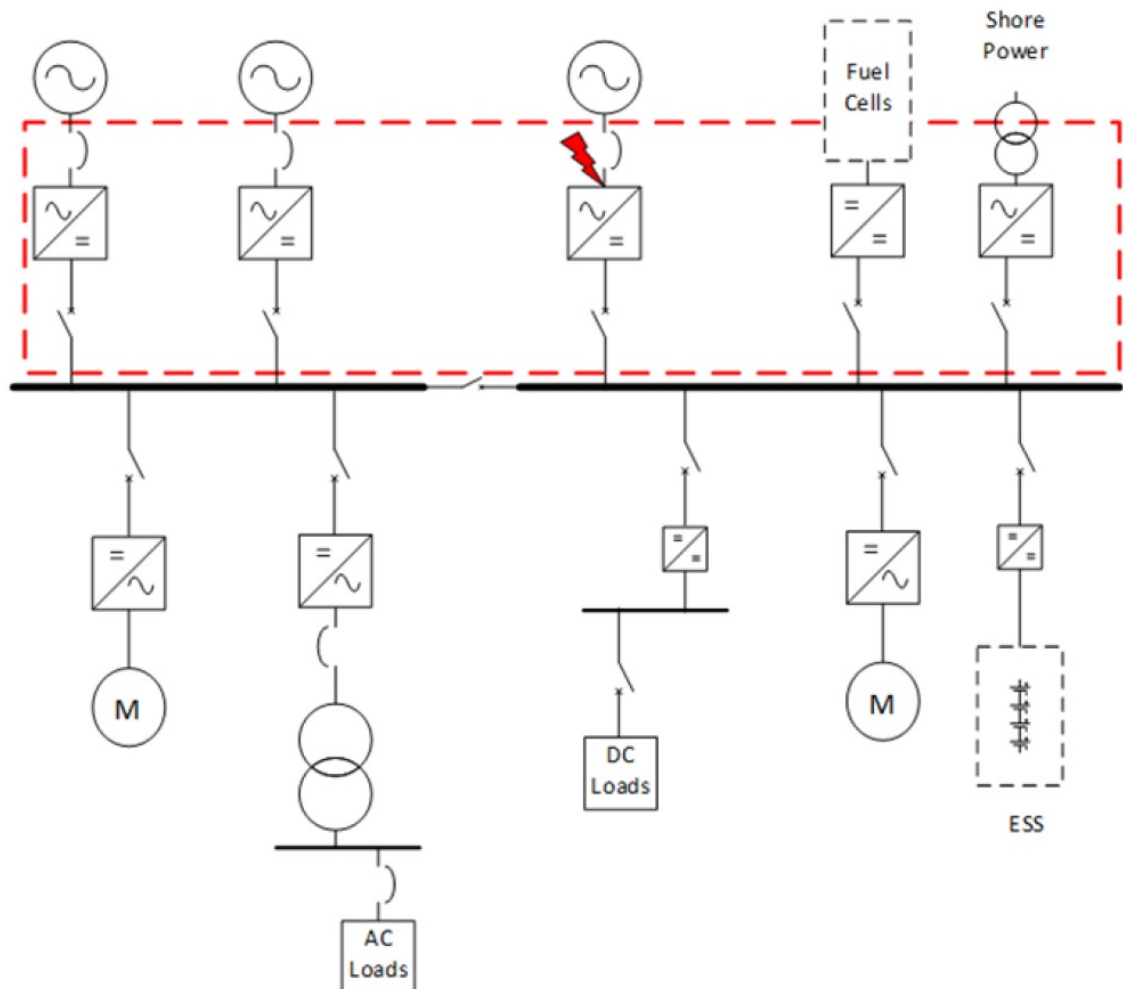

15.5.3 Protection within Zone on DC Bus

For fault conditions within this electrical network area, the following as a minimum is to be considered:

- i)* A means to detect fault current is to be provided in the protective devices connecting to the DC bus.
- ii)* The Power Management System is to react accordingly, after the activation of the generator protection unit, to prevent a blackout condition.
- iii)* The arrangements of the DC bus-tie disconnecting means and the protection system are to isolate the faulted DC bus section. The system is to be so arranged that if there is a fault on one section of the DC bus, the other healthy section(s) of the DC bus will be in operation after all protection systems have operated.
- iv)* For DC distribution systems supplied by AC generators, information including type test reports or proof by simulation is to be provided from the integrators/manufacturers to demonstrate:
 - a)* Coordination between the AC generator protection and rectifier module protection during a short-circuit current on the DC bus.

- b) Ability of the rectifier module to withstand damage during a short-circuit current on the DC bus.

FIGURE 3
Short Circuit Fault location 2 – On DC Bus
(example schematic for reference only)

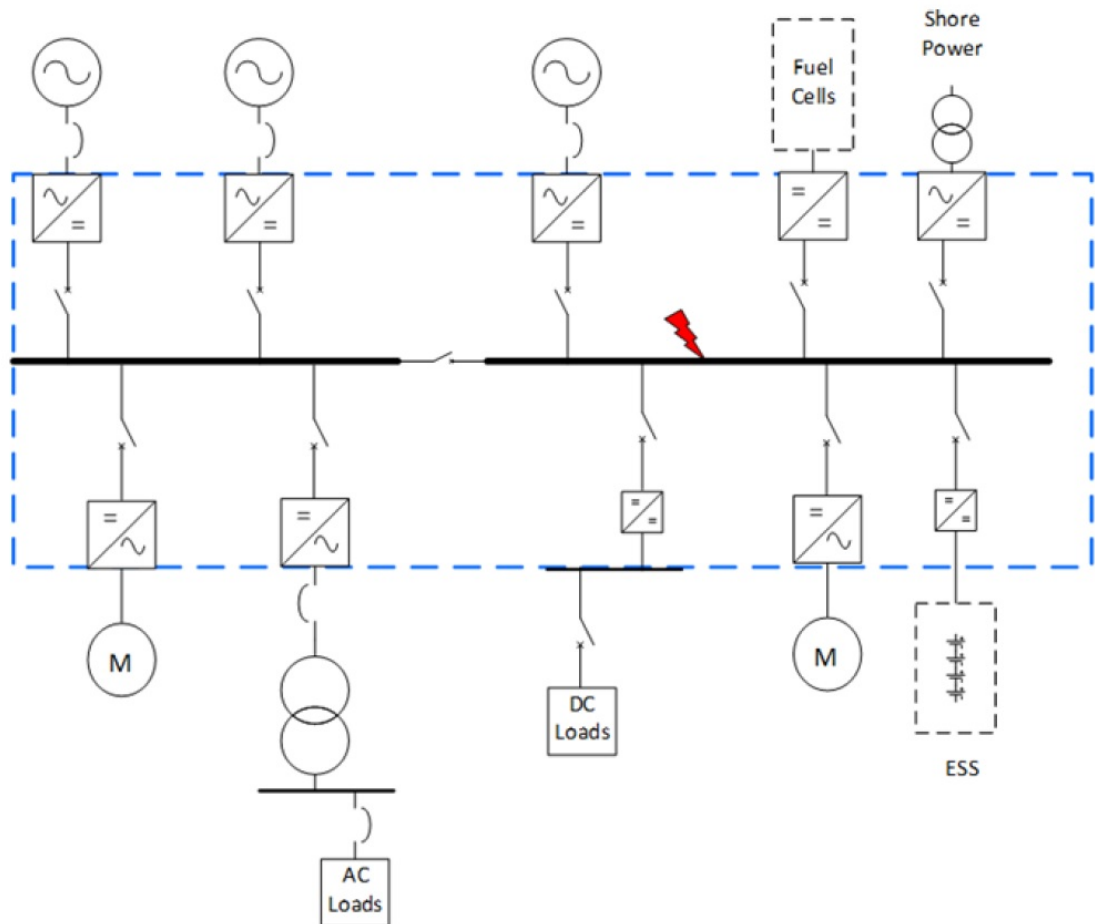

15.5.4 Protection within Zone Downstream of DC Bus

For fault conditions within this electrical network area, the following as a minimum is to be considered:

- i) The protective devices on the load side are to detect the fault and trip accordingly.
- ii) In the event of an internal fault in the power electronic converter module between the DC bus and the load, a back-up short circuit protection means is to be provided between the DC bus and the converter (such as fast-acting semiconductor fuses).
- iii) Coordination among the protective devices used for the different converter module capacitors is to be considered during the system protection coordination design.
- iv) In the event of a fault inside of a load converter module, only the fuses (or other protective device) protecting this particular module will trip, and other load converter modules connected to the same DC bus section are not to be affected.

FIGURE 4
Short Circuit Fault Location 3 – Downstream of DC Bus
(example schematic for reference only)

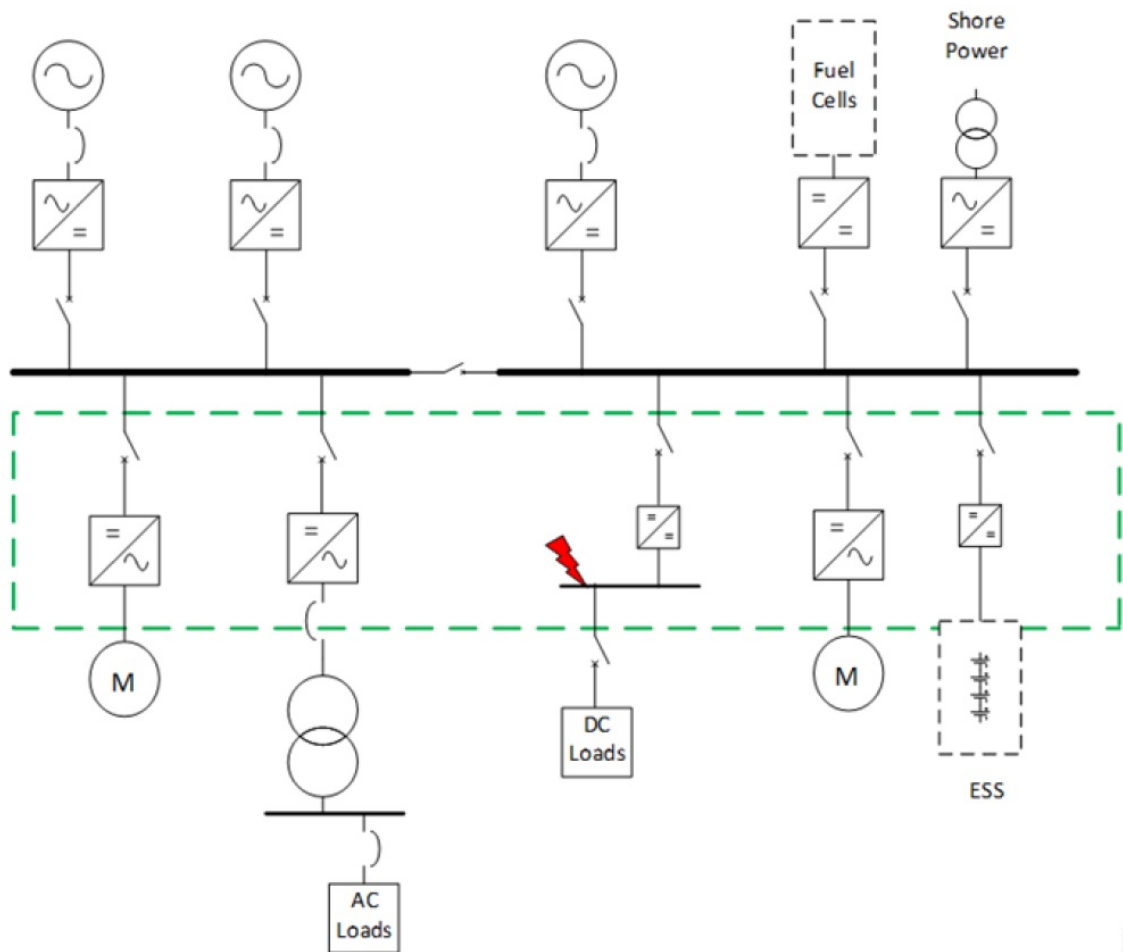

17 Risk Assessment

The primary objective of the risk assessment is to identify technical risks and uncertainties associated with the proposed DC power distribution system and control system design and its incorporation on a vessel. The risk assessment is to demonstrate the vessel's safety and the continuity of power supply in case of failure of any part of the system.

A Failure Mode and Effects Analysis (FMEA) study is typically implemented, but alternatively other risk assessment techniques may also be adopted. The use of other risk assessment techniques should be discussed with ABS prior to performing the risk assessment. The risk assessment is to be carried out in accordance with the *ABS Guidance Notes on Risk Assessment Application for the Marine and Offshore Industries*, *ABS Guidance Notes on Failure Mode and Effects Analysis (FMEA) for Classification*, or other ABS-recognized industry standards (e.g., IEC 60812).

All foreseeable hazards, their causes, consequences (local and global effects), and associated risk control measures are to be documented. The DC power distribution system risk assessment report is to be submitted for ABS review, and at a minimum is to address the following aspects:

- i) All normal and foreseeable abnormal operating conditions
- ii) Equipment layout, arrangement, and location

- iii)** Mechanical faults, electrical faults and human errors and associated alarms (e.g., earth fault, fire, flooding, cooling/heating failure, and operation exceeding the designed operating parameters)
- iv)** Software development, version updating, compatibility, and integrity
- v)** Electrical power system protection philosophy (e.g., loss of cooling power, loss of heating power, loss of control power, loss of power input to main supply, loss of power supply, loss of power on a single DC bus segment, DC breaker or other protection device failure, earth fault, short-circuit fault)
- vi)** Control component failure (e.g., temperature/pressure sensor failure, generator rectifier/ load inverter failure, DC bus-tie failure, main propulsion thruster drive failure, DP function thruster drive failure, loss of communication)
- vii)** Electrical shock precautions. The consideration that personnel cannot access energized equipment is to be given to the system design and equipment layout.
- viii)** Energy storage devices hazards if applicable (e.g., lithium-ion battery thermal runaway, see details of ESS operation hazards in the *Lithium-ion Battery Requirements* and the *Supercapacitor Requirements*).

SECTION 4 Installation, Testing, and Trials

1 General

Testing and commissioning trials are to be conducted to verify compliance of the DC distribution system with this document and compliance of the system components with desired technical specifications required in this document. The DC distribution system testing is to be in accordance with Sections 4-8-4 and 4-9-10 of the *Marine Vessel Rules* as applicable or other recognized standards (such as IEC 60092-350, IEEE Std 45-2002).

The DC distribution system components and associated control equipment and instrumentation are to be so placed or protected as to minimize the likelihood of sustaining damage from the accumulation of dust, oil vapors, steam or dripping liquids, or from activities around their location.

Upon completion of the installation, the DC power distribution system is to be tested under working conditions to the satisfaction of the Surveyor. The applicable FMEA validation tests based upon the risk assessment report are also to be conducted to the satisfaction of the Surveyor.

3 Testing and Trial Documents to be Submitted

The following are to be submitted to ABS and to be available to the attending Surveyor:

- i) Testing and trials schedule and procedure
- ii) Type tests report for DC system equipment
- iii) FAT test reports for essential equipment in DC power distribution
- iv) Inspection Procedure

5 Inspection and Testing

- i) Where required by this document, and Sections 4-8-3, 4-8-4 and 4-9-10 of the *Marine Vessel Rules*, equipment is to be inspected by, tested in the presence of and certified by the Surveyor, preferably at the plant of the manufacturer. Such equipment includes switchboard and distribution board, power electronic converters (for sources and loads connection and protection), PMS and control related equipment, protective devices (circuit breakers, switches, and fuses), bus duct, and cables as applicable.
- ii) Voltage tolerance testing of the system and the components is to be conducted to demonstrate the equipment capability of operating under the variations specified by the system designer.
- iii) Factory Acceptance Test (FAT) procedure is to include, but not limited to:
 - a) Visual inspection (e.g., exterior, cooling system pipes and hoses, converter, bus ducts/cables, earth insulation, protection equipment, connections, etc.)
 - b) Functional test

- c) Software test

7 Sea Trials

- i) Complete tests of the entire DC power distribution system are to be carried out during sea-trials including all normal operation functions, protection systems functions, safety functions, alarms, and indicators.
- ii) Operation and load testing during dock trials and sea trials are to be witnessed by an ABS Surveyor in order to verify the system design.
- iii) Failure trials or fault simulation tests, based on the FMEA, for optional Class notations such as **DPS-2**, **DPS-3**, or propulsion redundancy (**R1**, **R2**, **R1-S**, **R2-S**) are to be carried out during sea trials as applicable.

1 General

The provisions in this Section are for any vessel fitted with DC power distribution systems. These requirements are in addition to the provisions noted in other ABS Rules and/or Guides, as applicable. See the *ABS Rules for Survey after Construction (Part 7)* or Part 7 of the *MOU Rules* for further detailed requirements.

3 Surveys during Construction

This subsection pertains to surveys carried out on any vessel fitted with a DC power distribution system during construction, installation, and testing of the asset at the builder's yard/facility, including onboard testing and trials.

All testing listed in Section 4 (including FMEA validation tests) is to be carried out to the satisfaction of the attending Surveyor. The DC power distribution system is to be installed and tested in accordance with this document.

The following items are to be verified by the attending Surveyor:

- i) Location and Arrangements.* DC equipment is to be installed in accordance with the system one-line diagram and the general arrangement plan. The installation of the DC power distribution system components is to be effectively secured to the surrounding structure to the satisfaction of the attending Surveyor. Where the equipment is required to be installed in a space with ventilation and/or environmental control room, the intended space is to be verified.
- ii) Testing.* The DC system testing is to follow the approved sea trial/commissioning procedures and is to include at least the following items:
 - a)* Function and performance testing to demonstrate the desired design purpose
 - b)* Tests of alarms and safety systems for DC system and its components
 - c)* Emergency shutdown operation

5 Surveys after Construction

5.1 General

The DC power distribution system equipment is to be surveyed in conjunction with the Class required electrical system and equipment surveys.

5.3 Special Periodical Surveys

Surveyor is to carry out inspection per approved procedure.