

Requirements for

Materials and Welding for Stainless Steels



July 2022



REQUIREMENTS FOR

MATERIALS AND WELDING FOR STAINLESS STEELS
JULY 2022

American Bureau of Shipping
Incorporated by Act of Legislature of
the State of New York 1862

© 2022 American Bureau of Shipping. All rights reserved.
ABS Plaza
1701 City Plaza Drive
Spring, TX 77389 USA

Foreword (1 July 2022)

This document has been developed to give minimum requirements for properties, manufacturing processes and fabrication techniques applicable to common types of stainless steels used in the marine and offshore industries.

Austenitic stainless steels have different compositions and properties but also have many common characteristics. The materials cannot be hardened by heat treatment and are essentially nonmagnetic in the annealed condition. Austenitic stainless steels have excellent corrosion resistance, good formability and outstanding fracture toughness especially at cryogenic temperatures. Accordingly, austenitic stainless steels are widely used in the marine and offshore industries in structural members, pressure vessels and piping systems.

Ferritic-austenitic (duplex) stainless steels are two-phase structures consisting of ferrite and austenite. The most attractive characteristics of duplex is the combination of properties including high strength and excellent resistance to chloride stress corrosion cracking. The standard duplex grade has 22 wt. % chromium and is not sensitive to inter-granular corrosion. For harsher environments, super duplex grade may need higher alloy elements such as 25 wt. % chromium for improved pitting resistance. Duplex stainless steels are also widely used in marine and offshore applications, such as chemical tankers and sour service environments.

One challenge with stainless steels is that they may be susceptible to solidification cracking during welding. Cracking in stainless steel welds may be caused by low melting eutectic phases containing impurities, such as sulfur, phosphorus and other alloy elements. Nitrogen also has a complex effect on the weld metal microstructure and cracking. Nitrogen picked up during welding may significantly increase the risk of cracking. In addition, for duplex stainless steel welding, the ratio of ferrite to austenite may be difficult to control in the weld metal and heat affected zone.

This document covers four chapters pertaining to materials and welding for stainless steels:

- Chapter 1 contains general requirements for austenitic and duplex stainless steels.
- Chapter 2 contains the requirements for rolled materials, forgings, castings, pipes and stainless steel clad plates.
- Chapter 3 contains the requirements for various types of welding filler metals and the applicable base metals.
- Chapter 4 contains the requirements for welding procedures and welder qualification, production welding and fabrication, fabrication verification and nondestructive testing of production welds.

The general requirements and practices in this document provide qualification of materials and quality control in production and fabrication from raw materials to the end use in ships, offshore units, pressure vessels, piping systems or components.

The July 2022 version changes the document type from “Guide” to “Requirements”. “Requirements” documents contain mandatory criteria for Classification and issuance of Class Certificates, while Guides contain only requirements for optional Notations (see 1-1-4/1.5 of the *ABS Rules for Conditions of Classification (Part 1)*). The title is changed from “*Guide for Materials and Welding for Stainless Steels*” to “*Requirements for Materials and Welding for Stainless Steels*”. Accordingly, editorial changes are made throughout this document.

This document becomes effective on 1 April 2019.

Users are advised to check periodically on the ABS website www.eagle.org to verify that this version is the most current.

We welcome your feedback. Comments or suggestions can be sent electronically by email to rsd@eagle.org.



REQUIREMENTS FOR

MATERIALS AND WELDING FOR STAINLESS STEELS

CONTENTS

| | | |
|------------------|--|------------|
| CHAPTER 1 | General Requirements..... | 1 |
| Section 1 | General Requirements for Stainless Steels..... | 3 |
| Appendix 1 | List of Destructive and Nondestructive Tests Required for Materials and Responsibility for Verifying..... | 9 |
| Appendix 2 | List of Reference Documents..... | 11 |
| | | |
| CHAPTER 2 | Requirements for Stainless Steels..... | 16 |
| Section 1 | Rolled Stainless Steel Plates, Sheet, Strip, Sections and Bars..... | 22 |
| Section 2 | Stainless Steel Forgings..... | 30 |
| Section 3 | Stainless Steel Castings..... | 41 |
| Section 4 | Stainless Steel Pipes..... | 51 |
| Section 5 | Stainless Steel Clad Plates..... | 60 |
| Appendix 1 | Procedure for the Approval of Manufacturers of Rolled Stainless Steels..... | 65 |
| Appendix 2 | Fatigue Properties of Stainless Steels (For Reference).. | 80 |
| Appendix 3 | Corrosion Properties of Stainless Steels (For Reference)..... | 85 |
| | | |
| CHAPTER 3 | Stainless Steel Welding Filler Metals..... | 92 |
| Section 1 | Application of Stainless Steel Welding Filler Metals..... | 94 |
| Section 2 | Approval of Stainless Steel Welding Filler Metals..... | 97 |
| | | |
| CHAPTER 4 | Welding of Stainless Steels..... | 106 |
| Section 1 | Welding Procedure Qualification..... | 110 |
| Section 2 | Welding Operator and Welder Qualification..... | 117 |
| Section 3 | Production Welding and Fabrication..... | 123 |
| Section 4 | Fabrication Verification and Nondestructive Testing of Production Welds..... | 130 |
| Appendix 1 | Guidance for Handling and Storage of Stainless Steels | 146 |

CONTENTS

| | | | |
|-----------------|----------|--|----------|
| SECTION | 1 | General Requirements for Stainless Steels..... | 3 |
| | 1 | Scope..... | 3 |
| | 1.1 | General..... | 3 |
| | 1.2 | Application..... | 3 |
| | 2 | Testing and Inspection..... | 4 |
| | 2.1 | General..... | 4 |
| | 2.2 | Approval of Manufacturers..... | 4 |
| | 2.3 | Test and Test Data | 5 |
| | 2.4 | Certification on the Basis of the ABS Quality Assurance Program for Rolled Products..... | 5 |
| | 2.5 | Rejection of Previously Accepted Material | 5 |
| | 2.6 | Calibrated Testing Machines | 5 |
| | 2.7 | Reference Documents..... | 5 |
| | 3 | Defects..... | 5 |
| | 4 | Identification of Materials..... | 6 |
| | 5 | Manufacturer’s Documentation..... | 6 |
| | 6 | Marking, Retest and Rejection..... | 6 |
| | 6.1 | Identification of Specimens..... | 6 |
| | 6.2 | Retests..... | 6 |
| | 6.3 | Marking..... | 7 |
| | 6.4 | Rejection..... | 7 |
| | 7 | Standard Test Specimens..... | 7 |
| | 8 | Charpy Test..... | 7 |
| | 9 | Definition and Determination of Yield Point and Yield Strength..... | 7 |
| | 10 | Elongation | 8 |
| | 11 | Nondestructive Test | 8 |
| | 12 | Fracture Toughness Test..... | 8 |
| | | | |
| APPENDIX | 1 | List of Destructive and Nondestructive Tests Required for Materials and Responsibility for Verifying..... | 9 |
| | 1 | Test and Test Data..... | 9 |

| | | |
|-------------------|--|-----------|
| APPENDIX 2 | List of Reference Documents..... | 11 |
| 1 | Reference Documents..... | 11 |
| 1.1 | Chapter 1, Section 1 General Requirements for Stainless Steels..... | 11 |
| 1.2 | Chapter 2, Section 1 Rolled Stainless Steels..... | 11 |
| 1.3 | Chapter 2, Section 2 Stainless Steel Forgings..... | 12 |
| 1.4 | Chapter 2, Section 3 Stainless Steel Castings..... | 12 |
| 1.5 | Chapter 2, Section 4 Stainless Steel Pipes..... | 13 |
| 1.6 | Chapter 2, Section 5 Stainless Steel Clad Plates..... | 13 |
| 1.7 | Chapter 2, Appendix 2 Fatigue Property of Stainless Steels..... | 13 |
| 1.8 | Chapter 2, Appendix 3 Corrosion Property of Stainless Steels..... | 14 |
| 1.9 | Chapter 3, Section 1 Application of Stainless Steel Welding Filler Metals..... | 14 |
| 1.10 | Chapter 3, Section 2 Requirements for the Approval of Stainless Steel Welding Filler Metals..... | 14 |
| 1.11 | Chapter 4, Section 1 Welding Procedure Qualification.... | 14 |
| 1.12 | Chapter 4, Section 2 Welding Operator and Welder Qualification..... | 14 |
| 1.13 | Chapter 4, Section 3 Production Welding and Fabrication..... | 14 |
| 1.14 | Chapter 4, Section 4 Fabrication Verification and Nondestructive Testing of Production Welds..... | 14 |

CHAPTER 1 General Requirements

SECTION 1 General Requirements for Stainless Steels

1 Scope

1.1 General

In general, the requirements defined in Section 2-1-1 for Hull Construction and Section 2-3-1 for Machinery, Boilers, Pressure Vessels, and Piping of the *ABS Rules for Materials and Welding (Part 2)* are to be applied, unless there are specific requirements for stainless steels in this document.

The austenitic and ferritic-austenitic (duplex) stainless steel grades contained in this document follow the existing standard grades designations given in ASTM, AISI, SAE, JIS, UNS, EN or other equivalent Standards.

This document covers chromium, chromium-nickel and chromium-manganese-nickel austenitic and duplex stainless steels. Ferritic, martensitic and precipitation-hardened stainless steels are to be produced in accordance with applicable recognized industry standards.

The weldability of stainless steels is different from carbon or low alloy steel as given in Section 2-4-1 of the *ABS Rules for Materials and Welding (Part 2)*, therefore, welding requirements specified in this document are applicable. In addition, reference is to be made to the recognized welding code such as AWS D1.6 or equivalent.

In the case that requirements are not consistent between this document and ABS Rules or industry standards, the higher requirements are to be followed.

1.2 Application

Austenitic and duplex stainless steel products in this document are to be primarily used during the construction of cargo tanks, storage tanks, process pressure vessels and piping for carrying chemicals, liquefied gases and other general applications.

Austenitic stainless steels can be used for cryogenic applications. For elevated temperature applications, chemical composition, mechanical properties, high temperature mechanical properties and heat treatment are to be submitted to ABS for review.

Duplex stainless steels are generally to be used for a temperature range of -20°C (-4°F) to 275°C (527°F). For applications outside of this temperature range, the details and specifications are to be submitted to ABS for review and acceptance.

For application of stainless steels in Liquefied Gases application, reference is to be made to Section 5C-8-6 of the *ABS Rules for Building and Classing Marine Vessels (Marine Vessel Rules)*.

For application of stainless steels in propeller castings, reference is to be made to Section 2-3-15 of the *ABS Rules for Materials and Welding (Part 2)* and Appendix 7-A-10 of the *ABS Rules for Survey after Construction (Part 7)*.

2 Testing and Inspection

The general requirements for the testing and inspection are defined in 2-1-1/1 and 2-3-1/1 of the *ABS Rules for Materials and Welding (Part 2)*. In addition, the specific requirements defined in this document are also applicable to stainless steels.

2.1 General

All materials subject to test and inspection, intended for use in the construction of hulls and equipment of vessels classed or proposed for classification, are to be to the satisfaction of the Surveyor and in accordance with the following requirements or an equivalent standard/specification. Materials, test specimens and mechanical testing procedures with characteristics differing from those prescribed herein may be approved depending upon application, due regard being given to established practices in the country where the material produced and the purpose to be intended (such as the type of vessel and intended service), the nature of the construction of the vessel, and the parts to be used.

2.2 Approval of Manufacturers

2.2.1 Steel Works

All products for hull construction are to be manufactured at steel works approved by ABS for the type and grade of stainless steels contemplated. The suitability of the products for welding and assumed forming is to be demonstrated during the initial approval test at the steel works. Approval of the steel works for rolled stainless steel products is to be in accordance with Chapter 2, Appendix 1.

2.2.2 Procedures and Production Controls

It is the manufacturer's responsibility to maintain effective procedures and production controls during the production and adhere to the manufacturing specifications. Should any deviation from the procedures and controls occur that could produce an inferior product, the manufacturer is to carry out a thorough investigation to determine the cause of the deviation and establish countermeasures to prevent its reoccurrence. A complete investigation report is to be submitted to the ABS Surveyor. ABS reserves the right to request a closer survey until the cause is resolved to the satisfaction of the Surveyor. Each affected piece is to be tested to the satisfaction of the attending Surveyor prior to distribution from the steel works. In addition, the frequency of testing for subsequent products may be increased to gain confidence in the quality.

2.2.3 Suppliers other than Steel Works

For suppliers other than steel works, such as stainless steel forgings, castings, pipes and clad plates, the approval of facility is to comply with procedures in the applicable Section in this document and/or obtain specific instruction approved by ABS.

2.2.4 Radiation

It is the manufacturer's responsibility to confirm that raw materials, semi-finished/finished cast products or wrought steel products are produced within radioactive contamination limits as permitted by an appropriate regulatory body/agency, as applicable to the location of manufacturer. Radiation levels and reference to the allowed limits are to be specified and documented in manufacturer's QA/QC procedures.

2.3 Test and Test Data

2.3.1 Witnessed Tests

The designation (W) indicates that a Surveyor is to witness the testing unless the plant is enrolled and product is manufactured under ABS's Quality Assurance Program.

2.3.2 Manufacturer's Data

The designation (M) indicates that test data is to be provided by the manufacturer without verification by a Surveyor of the procedures used or the results obtained.

2.3.3 Other Tests

The designation (A) indicates those tests for which test data is to be provided by the supplier and audited by the Surveyor to verify that the procedures used and random tests witnessed are in compliance with the requirements.

Chapter 1, Appendix 1 has a complete listing of indicated designations for the various tests called out.

2.4 Certification on the Basis of the ABS Quality Assurance Program for Rolled Products

Upon application, consideration will be given to the acceptance of plates, shapes and bars without witnessing of mechanical tests by the Surveyor, on the basis of compliance with ABS's Quality Assurance Program.

2.5 Rejection of Previously Accepted Material

In the event of any material proving unsatisfactory while in the process of being worked, it is to be rejected, notwithstanding any previous certificate of satisfactory testing.

2.6 Calibrated Testing Machines

The Surveyor is to be satisfied that the testing machines are maintained in a satisfactory and accurate condition including a record of the dates and by whom the machines were rechecked or calibrated. All tests are to be carried out to a recognized national or international Standard (e.g., ISO 17025 or equivalent) by competent personnel.

2.7 Reference Documents

References are given in Chapter 1, Appendix 2 to various specifications from the American Society for Testing and Materials (ASTM), American Welding Society (AWS), American Society of Mechanical Engineers (ASME) or other equivalent specification designations without year notations. Unless otherwise noted, the latest issue of the specification is to be used.

3 Defects

All materials are to be free from cracks, injurious surface flaws, injurious laminations and similar defects. Except as indicated for specific materials, welding or dressing for the purpose of repairing defects is not permitted unless sanctioned by the Surveyor. In such cases where sanction is required for materials to be so treated, the Surveyor may prescribe further investigation and necessary treatment; then, if found satisfactory, the treated part is to be stamped with the Surveyor's identification mark using special marking pen for stainless steels.

Surface defects may be removed by grinding. Rectification of defects by other methods will be subject to the special consideration.

4 Identification of Materials

The manufacturer is to adopt a system for the identification and tracking of ingots, slabs, finished plates, shapes, forgings, castings and pipes to enable the material to be traced to its original heat, and the Surveyor is to be given every facility for so tracing the material.

5 Manufacturer's Documentation

The requirements for manufacturer's certificates are defined in 2-1-1/7 and 2-3-1/7 of the *ABS Rules for Materials and Welding (Part 2)*.

The supplier is to enable the materials to be traced to its original heat number, lot number, test and re-test results. Supplier is to furnish the Material Test Report (MTR) as follows:

- i) Purchaser's name and order number
- ii) Specifications or grades
- iii) Manufacturing process such as melting, casting, rolling, and forging
- iv) Dimensions
- v) Weight
- vi) Heat Number/Identification of Materials
- vii) Lot Number
- viii) Chemical composition
- ix) Mechanical properties
- x) Corrosion test results if required
- xi) Nondestructive test results if required
- xii) Identification number of piece, including test specimen number where appropriate
- xiii) Address to which material is dispatched

6 Marking, Retest and Rejection

6.1 Identification of Specimens

Where test specimens are required to be selected by the Surveyor, they are not to be detached until stamped with his identification mark, nor are they to be detached until the material has received its final treatment.

If any test specimen shows defective machining or develops defects, it may be discarded and another specimen substituted, except that a retest is not allowed for forgings if a defect develops during testing which is caused by rupture, cracks or flakes in the steel.

6.2 Retests

If the results of the mechanical tests do not conform to the requirements specified, re-test samples representative of the product or product batch are to be taken in accordance with the following relevant sections of the *ABS Rules for Materials and Welding (Part 2)*.

- i) 2-1-2/9.11: Tensile retest for Hull Construction
- ii) 2-1-2/11.7: Charpy retest for Hull Construction
- iii) 2-1-1/9.5: Elongation retest for Hull construction
- iv) 2-3-1/9.5: Elongation retest for Machinery, Boilers, Pressure Vessel and Piping
- v) 2-3-2/1.13: Tensile retest for Machinery, Boilers, Pressure Vessel and Piping

6.3 Marking

In addition to appropriate identification markings of the manufacturer, ABS markings, indicating satisfactory compliance with the requirements and as furnished by the Surveyor, are to be stamped on all products in such locations as to be discernible after machining and installation.

The finished products are to be clearly marked including:

- AB/Grade such as AB/304L, and AB/2205
- AB/31803 for the UNS designation 31803 for rolled stainless steel, stainless steel forgings and pipes, which does not have an ABS designated grade
- Heat Number or Identification of Materials for traceability

If dual certification is applied, all requirements of both grades or designations are to be met and verified.

For stainless steels, the marking paint or ink is not to contain detrimental amounts of harmful metals or metal salts, such as zinc, lead or copper, which may cause corrosive attack upon heating.

6.4 Rejection

2-1-2/9.13 of the *ABS Rules for Materials and Welding (Part 2)* is applicable for rejection.

In cases where a set of test specimens fails to meet the test and re-test requirements, the material from which such specimens have been taken is to be rejected and the required marking withheld or obliterated, unless the manufacturer elects to submit each piece individually, or to resubmit the lot after rework.

Any material that has unacceptable injurious discontinuities observed prior to or subsequent to acceptance at the manufacturer's plant is subject to rejection.

7 Standard Test Specimens

The requirements for preparations of specimens for tension test, impact test, and bend test are defined in 2-1-1/11 and 2-3-1/11 of the *ABS Rules for Materials and Welding (Part 2)*. At the discretion of ABS, the standard test specimens may be accepted in accordance with other equivalent industry standards for example, ASTM A370, E10, or E23.

8 Charpy Test

The requirements for Charpy tests are defined in 2-1-1/11.11 of the *ABS Rules for Materials and Welding (Part 2)*.

Note:

For 1-1/8, "Charpy Test": With the agreement of ABS (and the Administration for Liquefied Gases carriers, ref Section 5C-8-6 of the *Marine Vessel Rules*), impact tests may be waived for austenitic stainless steels. However, where it is found or suspected that grades might not be met the required 41 Joules (30 ft-lbf) in the longitudinal direction, ABS will request confirmatory Charpy tests.

9 Definition and Determination of Yield Point and Yield Strength

The yield strength and UTS are defined in 2-1-1/13 and 2-3-1/13 of the *ABS Rules for Materials and Welding (Part 2)*.

During tension testing, austenitic and duplex stainless steels usually do not exhibit the yield phenomenon observed with ferritic steels. Therefore, the yield point is determined by the 0.2% or 1.0% proof stress. A line parallel to the straight elastic portion of the load/extension graph is plotted at a distance of 0.2% or

1.0% of the extensometer gauge length. The proof yield is determined as the point where the 0.2% or 1% parallel line intersects the load extension curve.

10 Elongation

The elongation value is, in principle, valid only if the distance between the fracture and the nearest gauge mark is not less than one-third of the original gauge length. However, the result is valid, irrespective of the location of the fracture, if the percentage of elongation after the fracture is equal to or greater than the required value.

Generally, the elongation, A_5 , is determined on a proportional gauge length, $5.65\sqrt{S_0} = 5d$, but may also be given for other specified gauge lengths. The minimum elongation requirement in this document is based on the 50 mm (2 in.) gauge length.

11 Nondestructive Test

The requirements for nondestructive testing are to be defined in each Section of this document.

12 Fracture Toughness Test

If specified or required, the requirements for fracture toughness test are defined in 2-1-1/23 of the *ABS Rules for Materials and Welding (Part 2)*.

CHAPTER 1
General Requirements

APPENDIX 1

List of Destructive and Nondestructive Tests Required for Materials and Responsibility for Verifying

1 Test and Test Data

- i) Witnessed Tests.* The designation (W) indicates that a Surveyor is to witness the testing unless the plant is enrolled and product is manufactured under ABS’s Quality Assurance Program.
- ii) Manufacturer’s Data.* The designation (M) indicates that test data is to be provided by the manufacturer without verification by a Surveyor of the procedures used or the results obtained.
- iii) Other Tests.* The designation (A) indicates those tests for which test data is to be provided by the supplier and audited by the Surveyor to verify that the procedures used and random tests witnessed are in compliance with the requirements.

| Chapter 1, Section 1 General Requirements for Stainless Steels | |
|---|--|
| 1-1/7 | Standard Test Specimens (W) |
| 1-1/8 | Charpy (W) |
| 1-1/8 | Tensile Test (W) |
| Chapter 2, Section 1 Rolled Stainless Steels | |
| 2-1/5 | Ladle Analysis (M) Product Analysis (M) |
| 2-1/7 | Microstructure (W), if specified |
| 2-1/8 | Tensile Test (W) Charpy Test (W) |
| 2-1/9 | Corrosion Test (A) Test Results (W) |
| 2-1/10 | Inspection (A) |
| Chapter 2, Section 2 Stainless Steel Forgings | |
| 2-2/5 | Ladle Analysis (M) |

| | |
|---|---|
| 2-2/7 | Tensile Test (W) Charpy Test (W) Hardness Test (W) |
| 2-2/8 | Corrosion Test (A) Test Results (W), if specified |
| 2-2/9 | Inspection (A) |
| Chapter 2, Section 3 Stainless Steel Castings | |
| 2-3/5 | Ladle Analysis (M) |
| 2-3/7 | Tensile Test (W) Charpy Test (W) Hardness Test (W) |
| 2-3/8 | Corrosion Test (A) Test Results (W), if specified |
| 2-3/9 | Dye Penetrant Inspection (A) Ultrasonic Inspection (A) |
| Chapter 2, Section 4 Stainless Steel Pipes | |
| 2-4/5 | Ladle Analysis (M) Product Analysis (M) |
| 2-4/7 | Tensile Test (W) Charpy Test (W) Hardness Test (W) Bend Test (W) Flatten Test (W) |
| 2-4/8 | Corrosion Test (A) Test Results (W) |
| 2-4/9 | Hydrostatic Test (W) |
| 2-4/10 | Dimension Verification (A) |
| 2-4/11 | Inspection (A) |
| Chapter 2, Section 5 Stainless Steel Clad Plates | |
| 2-5/5 | Chemical Composition (M) |
| 2-5/7 | Tensile Test (W) Charpy Test (W) Shear Test (W) Bend Test Bonding Strength (W) |
| 2-5/8 | Corrosion Test (A) Test Results (W) |
| 2-5/9 | Inspection (A) |

CHAPTER 1 General Requirements

APPENDIX 2 List of Reference Documents

1 Reference Documents

Frequently-used reference documents are listed in this Appendix for relevant standards from the American Society for Testing and Materials (ASTM), American Welding Society (AWS), American Society of Mechanical Engineers (ASME) and other equivalent specification designations. Unless otherwise noted, the latest issue of the specification is to be used.

1.1 Chapter 1, Section 1 General Requirements for Stainless Steels

ABS Rules: Materials and Welding (Part 2)

ASTM A262: Standard Practices for Detecting Susceptibility to Intergranular Attack in Austenitic Stainless Steels

ASTM A370: Standard Test Methods and Definitions for Mechanical Testing of Steel Products

ASTM A751: Standard Test Methods, Practices, and Terminology for Chemical Analysis of Steel Products

ASTM A923: Standard Test Methods for Detecting Detrimental Intermetallic Phase in Duplex Austenitic/Ferritic Stainless Steels

ASTM E10: Standard Test Method for Brinell Hardness of Metallic Materials

ASTM E23: Standard Test Methods for Notched Bar Impact Testing of Metallic Materials

ASTM E562: Standard Test Method for Determining Volume Fraction by Systematic Manual Point Count

ASTM G48: Standard Test Methods for Pitting and Crevice Corrosion Resistance of Stainless Steels and Related Alloys by Use of Ferric Chloride Solution

ASTM G78: Standard Guide for Crevice Corrosion Testing of Iron-Base and Nickel-Base Stainless Alloys in Seawater and Other Chloride-Containing Aqueous Environments

NACE MR0175: Materials for use in H₂S-containing environments in oil and gas production

1.2 Chapter 2, Section 1 Rolled Stainless Steels

ASTM A240: Specification for Chromium and Chromium-Nickel Stainless Steel Plate, Sheet, and Strip for Pressure Vessels and for General Applications

ASTM A276: Standard Specification for Stainless Steel Bars and Shapes

ASTM A435: Standard Specification for Straight-Beam Ultrasonic Examination of Steel Plates

ASTM A480: Standard Specification for General Requirements for Flat-Rolled Stainless and Heat Resisting Steel Plate, Sheet, and Strip

ASTM A578: Standard Specification for Straight-Beam Ultrasonic Examination of Rolled Steel Plates for Special Applications

BSSA 2018: Selection of 316, 304 and 303 types of stainless steels for seawater applications

EN 10088-2: Stainless Steels Technical Delivery Conditions for Sheet/Plate and Strip of Corrosion Resisting Steels for General Purposes

1.3 Chapter 2, Section 2 Stainless Steel Forgings

ASTM A182: Standard Specification for Forged or Rolled Alloy and Stainless Steel Pipe Flanges, Forged Fittings, and Valves and Parts for High-Temperature Service

ASTM A314: Standard Specification for Stainless Steel Billets and Bars for Forging

ASTM A336: Standard Specification for Alloy Steel Forgings for Pressure and High-Temperature Parts

ASTM A388: Standard Practice for Ultrasonic Examination of Steel Forgings

ASTM A473: Standard Specification for Stainless Steel Forgings

ASTM A745: Standard Practice for Ultrasonic Examination of Austenitic Steel Forgings

ASTM A788: Standard Specification for Steel Forgings, General Requirements

ASTM A965: Standard Specification for Steel Forgings, Austenitic, for Pressure and High Temperature Parts

EN 10228: Non-Destructive Testing of Steel Forgings. Ultrasonic Testing of Austenitic and Austenitic-Ferritic stainless steel forgings

1.4 Chapter 2, Section 3 Stainless Steel Castings

ASTM A297: Standard Specification for Steel Castings, Iron-Chromium and Iron-Chromium-Nickel, Heat Resistant, for General Application

ASTM A351: Standard Specification for Castings, Austenitic, Austenitic-Ferritic (Duplex), for Pressure Containing Parts

ASTM A488: Practice for Steel Castings, Welding, Qualification of Procedures and Personnel

ASTM A609: Standard Practice for Castings, Carbon, Low-Alloy, and Martensitic Stainless Steel, Ultrasonic Examination Thereof

ASTM A703: Standard Specification for Steel Castings, General Requirements, for Pressure Containing Parts

ASTM A743: Standard Specification for Castings, Iron-Chromium, Iron-Chromium-Nickel, Corrosion Resistant, for General Application

ASTM A744: Standard Specification for Castings, Iron-Chromium-Nickel, Corrosion Resistant, for Severe Service

ASTM E165: Standard Practice for Liquid Penetrant Examination for General Industry

1.5 Chapter 2, Section 4 Stainless Steel Pipes (1 December 2020)

ASTM A269: Standard Specification for Seamless and Welded Austenitic Stainless Steel Tubing for General Service

ASTM A312: Standard Specification for Seamless, Welded, and Heavily Cold Worked Austenitic Stainless Steel Pipes

ASTM A358: Standard Specification for Electric-Fusion-Welded Austenitic Chromium-Nickel Stainless Steel Pipe for High-Temperature Service and General Applications

ASTM A403: Standard Specification for Wrought Austenitic Stainless Steel Piping Fittings

ASTM E426: Standard Practice for Electromagnetic (Eddy Current) Examination of Seamless and Welded Tubular Products, Titanium, Austenitic Stainless Steel and Similar Alloys

ASTM A789: Standard Specification for Seamless and Welded Ferritic/Austenitic Stainless Steel Tubing for General Service

ASTM A790: Standard Specification for Seamless and Welded Ferritic/Austenitic Stainless Steel Pipe

ASTM A813: Standard Specification for Single- or Double-Welded Austenitic Stainless Steel Pipe

ASTM A815: Standard Specification for Wrought Ferritic, Ferritic/Austenitic, and Martensitic Stainless Steel Piping Fittings

ASTM A872: Standard Specification for Centrifugally Cast Ferritic/Austenitic Stainless Steel Pipe for Corrosive Environments

ASTM A928: Standard Specification for Ferritic/Austenitic (Duplex) Stainless Steel Pipe Electric Fusion Welded with Addition of Filler Metal

ASTM A999: Standard Specification for General Requirements for Alloy and Stainless Steel Pipe

ASTM E213: Standard Practice for Ultrasonic Testing of Metal Pipe and Tubing

ASTM A380: Standard Practice for Cleaning, Descaling, and Passivation of Stainless Steel Parts, Equipment, and Systems

1.6 Chapter 2, Section 5 Stainless Steel Clad Plates

ASTM A20: Specification for General Requirements for Steel Plates for Pressure Vessel

ASTM A263: Standard Specification for Stainless Chromium Steel-Clad Plate

ASTM A264: Specification for Stainless Chromium-Nickel Steel-Clad Plate

1.7 Chapter 2, Appendix 2 Fatigue Property of Stainless Steels

API 571: Damage Mechanisms Affecting Fixed Equipment in the Refining Industry

ASME BPVC II: Materials Part D-Properties

ASTM: Handbook Volume 19-Fatigue and Fracture

1.8 Chapter 2, Appendix 3 Corrosion Property of Stainless Steels

ASTM G82: Standard Guide for Development and Use of a Galvanic Series for Predicting Galvanic Corrosion Performance

NACE: Corrosion Engineer's Reference Book, 2nd Edition, 1991

NiDI: Design Guidelines for the Selection and Use of Stainless Steel

1.9 Chapter 3, Section 1 Application of Stainless Steel Welding Filler Metals

AWS A5.4: Specification for Stainless Steel Electrodes for Shielded Metal Arc Welding

AWS A5.9: Specification for Bare Stainless Steel Welding Electrodes and Rods

AWS A5.22: Specification for Stainless Steel Flux Cored and Metal Cored Welding Electrodes and Rods

AWS A5.30: Specification for Consumable Inserts

AWS D1.6: Structural Welding Code-Stainless Steel

1.10 Chapter 3, Section 2 Requirements for the Approval of Stainless Steel Welding Filler Metals

ASTM E353: Standard Test Methods for Chemical Analysis of Stainless, Heat Resisting, Maraging and Other Similar Chromium-Nickel-Iron Alloys

ASTM E562: Standard Test Method for Determining Volume Fraction by Systematic Manual Point Count

AWS A5.1: Procurement Guidelines for Consumables-Welding and Allied Processes-Flux and Gas Shielded Electrical Welding Processes

1.11 Chapter 4, Section 1 Welding Procedure Qualification

ASME BPVC IX: Welding, Brazing, and Fusing Qualifications

1.12 Chapter 4, Section 2 Welding Operator and Welder Qualification

ISO 3834-2: Comprehensive Quality Requirements for Fusion Welding of Metallic Materials

ISO 3834-3: Standard Quality Requirements for Fusion Welding of Metallic Materials

ISO 5817: Fusion-Welded Joints in Steel, Nickel, Titanium and Their Alloys (Beam Welding Excluded)-Quality Levels for Imperfections

ISO 14732: Qualification Testing of Welding Operators and Weld Setters for Mechanized and Automatic Welding of Metallic Materials

1.13 Chapter 4, Section 3 Production Welding and Fabrication

AWS B1.10: Guide for Nondestructive Inspection of Welds

1.14 Chapter 4, Section 4 Fabrication Verification and Nondestructive Testing of Production Welds

ASNT: Nondestructive Testing Handbook

ASNT CP-189: Standard for Qualification and Certification of Nondestructive Testing Personnel

ASNT-TC-1A: Personnel Qualification and Certification in Nondestructive Testing

EN 10228: Non-Destructive Testing of Steel Forgings. Ultrasonic Testing of Austenitic and Austenitic-Ferritic stainless steel forgings

ISO 9712: Qualification and Certification of NDT personnel

CONTENTS

| | | | |
|----------------|----------|--|-----------|
| SECTION | 1 | Rolled Stainless Steel Plates, Sheet, Strip, Sections and Bars..... | 22 |
| | 1 | Scope..... | 22 |
| | 2 | Reference Documents..... | 22 |
| | 3 | Approval of Manufacturers..... | 23 |
| | 4 | Manufacturing Process | 23 |
| | 5 | Chemical Composition..... | 23 |
| | 6 | Heat Treatment..... | 23 |
| | 7 | Microstructure..... | 24 |
| | 8 | Mechanical Properties..... | 24 |
| | 8.1 | Test Specimens and Procedures..... | 24 |
| | 8.2 | Test Frequency..... | 24 |
| | 8.3 | Additional Test Frequency..... | 24 |
| | 8.4 | Test Specimen Location..... | 25 |
| | 8.5 | Test Temperature..... | 25 |
| | 9 | Corrosion Properties..... | 25 |
| | 10 | Steel Plates with Specified Minimum Through Thickness Properties..... | 25 |
| | 11 | Permissible Variations in Dimensions | 25 |
| | 12 | Inspection..... | 26 |
| | 13 | Marking, Retests and Rejection..... | 26 |
| | 14 | Material Test Report (MTR)..... | 26 |
| | TABLE 1 | Chemical Composition of Rolled Stainless Steels..... | 26 |
| | TABLE 2 | Mechanical Property Requirements of Rolled Stainless Steels..... | 28 |
| SECTION | 2 | Stainless Steel Forgings..... | 30 |
| | 1 | Scope..... | 30 |
| | 2 | Reference Documents..... | 30 |
| | 3 | Approval of Manufacturers | 31 |
| | 4 | Manufacturing Process..... | 31 |
| | 5 | Chemical Composition | 32 |

| | | |
|---------|---|----|
| 6 | Heat Treatment..... | 32 |
| 6.1 | General..... | 32 |
| 6.2 | Retreatment..... | 33 |
| 7 | Mechanical Properties..... | 33 |
| 7.1 | Tensile and Charpy Properties..... | 33 |
| 7.2 | Hardness..... | 33 |
| 7.3 | Test Procedure and Specimens | 34 |
| 7.4 | Test Frequency and Position..... | 34 |
| 7.5 | Test Temperature | 35 |
| 8 | Corrosion Properties..... | 36 |
| 9 | Inspection..... | 36 |
| 10 | Rectification of Defective Forgings..... | 36 |
| 11 | Identification, Marking, Retests and Rejection..... | 37 |
| 11.1 | Identification..... | 37 |
| 11.2 | Retests..... | 37 |
| 11.3 | Marking..... | 37 |
| 11.4 | Rejection..... | 37 |
| 12 | Material Test Report (MTR)..... | 37 |
| TABLE 1 | Chemical Composition of Stainless Steel Forgings..... | 38 |
| TABLE 2 | Mechanical Property Requirements of Stainless Steel Forgings..... | 39 |

| | | |
|------------------|--------------------------------------|-----------|
| SECTION 3 | Stainless Steel Castings..... | 41 |
| 1 | Scope..... | 41 |
| 2 | Reference Documents..... | 41 |
| 3 | Approval of Manufacturers..... | 42 |
| 4 | Manufacturing Process..... | 42 |
| 5 | Chemical Composition..... | 43 |
| 6 | Heat Treatment..... | 43 |
| 6.1 | General | 43 |
| 6.2 | Retreatment..... | 44 |
| 7 | Mechanical Properties..... | 44 |
| 7.1 | Tensile and Charpy Properties..... | 44 |
| 7.2 | Hardness..... | 44 |
| 7.3 | Test Procedure and Specimens..... | 44 |
| 7.4 | Test Frequency..... | 45 |
| 7.5 | Test Temperature | 45 |
| 8 | Corrosion Properties..... | 45 |
| 9 | Inspection..... | 46 |
| 9.1 | General | 46 |
| 9.2 | Nondestructive Test..... | 46 |
| 9.3 | Minor Defects..... | 46 |

| | | |
|---------|---|----|
| 9.4 | Major Defects..... | 47 |
| 10 | Rectification of Defective Castings..... | 47 |
| 11 | Identification, Marking, Retests and Rejection | 47 |
| 11.1 | Identification..... | 47 |
| 11.2 | Retests..... | 47 |
| 11.3 | Marking..... | 47 |
| 11.4 | Rejection..... | 48 |
| 12 | Material Test Report (MTR)..... | 48 |
| TABLE 1 | Chemical Composition of Stainless Steel Castings..... | 48 |
| TABLE 2 | Mechanical Property Requirements of Stainless Steel Castings..... | 49 |

| | | |
|------------------|--|-----------|
| SECTION 4 | Stainless Steel Pipes..... | 51 |
| 1 | Scope..... | 51 |
| 2 | Reference Documents..... | 52 |
| 3 | Approval of Manufacturers | 52 |
| 4 | Manufacturing Process..... | 53 |
| 5 | Chemical Composition..... | 53 |
| 6 | Heat Treatment..... | 53 |
| 7 | Mechanical Properties..... | 53 |
| 7.1 | Test Specimens and Procedures..... | 53 |
| 7.2 | Test Frequency..... | 53 |
| 7.3 | Additional Requirements for Welded Pipe..... | 54 |
| 7.4 | Test Temperature | 54 |
| 7.5 | Test Specimen Location..... | 54 |
| 8 | Corrosion Properties..... | 54 |
| 9 | Hydrostatic Test..... | 55 |
| 9.1 | General | 55 |
| 9.2 | Test Pressure..... | 55 |
| 10 | Permissible Variation | 55 |
| 10.1 | Permissible Variation in Wall Thickness..... | 55 |
| 10.2 | Permissible Variation in Inside Diameter..... | 56 |
| 10.3 | Permissible Variation in Outside Diameter..... | 56 |
| 11 | Inspection..... | 56 |
| 12 | Marking, Retest and Rejection..... | 56 |
| 13 | Material Test Report (MTR)..... | 56 |
| TABLE 1 | Chemical Composition of Stainless Steel Pipes..... | 57 |
| TABLE 2 | Mechanical Properties Requirements of Stainless Steel Pipes..... | 58 |

| | | |
|------------------|---|-----------|
| SECTION 5 | Stainless Steel Clad Plates..... | 60 |
|------------------|---|-----------|

| | | |
|----|--------------------------------------|----|
| 1 | Scope..... | 60 |
| 2 | Reference Documents..... | 60 |
| 3 | Approval of Manufacturers..... | 61 |
| 4 | Manufacturing Process..... | 61 |
| | 4.1 Base Metal..... | 61 |
| | 4.2 Clad Metal..... | 61 |
| | 4.3 Bonded Products..... | 61 |
| 5 | Chemical Composition..... | 61 |
| | 5.1 Base Metal..... | 61 |
| | 5.2 Clad Metal..... | 61 |
| 6 | Heat Treatment..... | 62 |
| | 6.1 Base Metal..... | 62 |
| | 6.2 Clad Metal..... | 62 |
| 7 | Mechanical Properties..... | 62 |
| | 7.1 Tensile Test..... | 62 |
| | 7.2 Charpy Test..... | 63 |
| | 7.3 Shear Test..... | 63 |
| | 7.4 Bend Test Bonding Strength | 63 |
| 8 | Corrosion Properties..... | 63 |
| 9 | Inspection..... | 63 |
| 10 | Defects and Repair..... | 64 |
| 11 | Marking..... | 64 |
| 12 | Material Test Report (MTR)..... | 64 |

APPENDIX 1 Procedure for the Approval of Manufacturers of Rolled Stainless Steels.....65

| | | |
|---|---|----|
| 1 | Scope..... | 65 |
| | 1.1 General..... | 65 |
| | 1.2 Range of Approval..... | 65 |
| 2 | Reference Documents..... | 66 |
| 3 | Approval Application..... | 66 |
| | 3.1 Documents to be Submitted..... | 66 |
| 4 | Approval Tests..... | 68 |
| | 4.1 Extent of the Approval Tests..... | 68 |
| | 4.2 Approval Test Program..... | 69 |
| | 4.3 Approval Survey..... | 69 |
| | 4.4 Selection of the Test Product..... | 69 |
| | 4.5 Position of the Test Samples..... | 69 |
| | 4.6 Tests on Base Material..... | 72 |
| | 4.7 Weldability Tests for Austenitic and Duplex Stainless Steels..... | 76 |
| | 4.8 Nondestructive Tests..... | 78 |
| | 4.9 Other Tests..... | 78 |
| 5 | Results..... | 78 |

| | | |
|----------|---|----|
| 6 | Certification for Stainless Steel Mill..... | 78 |
| 6.1 | Approval..... | 78 |
| 6.2 | List of Approved Manufacturers..... | 78 |
| 7 | Renewal of Approval..... | 78 |
| 8 | Withdrawal of the Approval..... | 79 |
| TABLE 1 | Tests for Rolled Austenitic Stainless Steel Products Manufacturer Approval | 74 |
| TABLE 2 | Tests for Rolled Duplex Stainless Steel Products Manufacturer Approval | 75 |
| FIGURE 1 | Position of the Test Samples – Plates and Flats..... | 70 |
| FIGURE 2 | Position of the Test Samples – Bulb Flats | 70 |
| FIGURE 3 | Position of the Test Samples – Angles..... | 71 |
| FIGURE 4 | Position of the Test Samples – Unequal Angles..... | 71 |
| FIGURE 5 | Position of the Test Samples – Channels and Beams..... | 71 |
| FIGURE 6 | Position of the Test Samples – Sections (Joists)..... | 72 |
| FIGURE 7 | Position of the Test Samples – Flats and Rounds (Bars)..... | 72 |

APPENDIX 2 Fatigue Properties of Stainless Steels (For Reference)..... 80

| | | |
|---|-------------------------------|----|
| 1 | Scope | 80 |
| 2 | Reference Documents..... | 80 |
| 3 | Fatigue Characteristics..... | 80 |
| 4 | Design..... | 81 |
| 5 | Fracture Morphology..... | 81 |
| 6 | Corrosion Fatigue..... | 81 |
| 7 | Prevention or Mitigation..... | 82 |

| | | |
|---------|---|----|
| TABLE 1 | Design Fatigue Strain Range, ϵ_p , for 304 Stainless Steel (2)..... | 82 |
|---------|---|----|

| | | |
|---------|---|----|
| TABLE 2 | Design Fatigue Strain Range, ϵ_p , for 316 Stainless Steel (2)..... | 83 |
|---------|---|----|

| | | |
|----------|---|----|
| FIGURE 1 | Design Fatigue Strain Range, ϵ_p , for 304 Stainless Steel (1,2)..... | 83 |
|----------|---|----|

| | | |
|----------|---|----|
| FIGURE 2 | Design Fatigue Strain Range, ϵ_p , for 316 Stainless Steel (1,2)..... | 84 |
|----------|---|----|

APPENDIX 3 Corrosion Properties of Stainless Steels (For Reference)..... 85

| | | |
|---|---|----|
| 1 | Scope..... | 85 |
| 2 | Reference Documents..... | 85 |
| 3 | Corrosion Resistance of Stainless Steels..... | 85 |
| 4 | Uniform and Localized Corrosion | 86 |
| 5 | Galvanic Corrosion | 86 |

| | | |
|--|--------------------------------------|----|
| 6 | Pitting | 87 |
| 7 | Crevice Corrosion | 87 |
| 8 | Intergranular Corrosion | 87 |
| 9 | Stress Corrosion Cracking (SCC)..... | 88 |
| 10 | Erosion-Corrosion..... | 88 |
| TABLE 1 Effect of Alloy Elements on Stainless Steels..... | | 89 |
| TABLE 2 Galvanic Series of Metals Exposed to Seawater ^(1,2) | | 90 |

CHAPTER 2

Requirements for Stainless Steels

SECTION 1

Rolled Stainless Steel Plates, Sheet, Strip, Sections and Bars

1 Scope

The general requirements defined in Sections 2-3-2 and 2-3-8 of the *ABS Rules for Materials and Welding (Part 2)* are to be applied, unless there are specific requirements for rolled stainless steels in this document.

This Section covers chromium, chromium-nickel and chromium-manganese-nickel rolled stainless steel plate, sheet, strip, sections and bars including requirements for:

- i) Manufacturing process
- ii) Chemical composition
- iii) Mechanical properties
- iv) Corrosion properties
- v) Nondestructive test

The requirements are primarily intended to apply to austenitic and ferritic-austenitic (duplex) stainless steel products with a thickness as follows:

- i) For steel plates, sections and wide flats, all Grades are up to 50 mm (2 in.) in thickness.
- ii) For bars, all Grades are up to 300 mm (12 in.) in OD (Outside Diameter).

Note:

Materials may be produced in ferritic, martensitic and precipitation hardened stainless steels in accordance with the applicable recognized industry standards and submitted to ABS for review.

The requirements in this Section cover rolled stainless steels intended to be used for general marine and offshore applications. Alternatively, rolled stainless steels which comply with national or proprietary specifications may be accepted, provided such specifications establish an equivalence to these requirements.

2 Reference Documents

ASTM A240: Specification for chromium and chromium-nickel Stainless Steel Plate, Sheet, and Strip for Pressure Vessels and for General Applications

ASTM A276: Standard Specification for Stainless Steel Bars and Shapes

ASTM A435: Standard Specification for Straight-Beam Ultrasonic Examination of Steel Plates

ASTM A480: Standard Specification for General Requirements for Flat-Rolled Stainless and Heat Resisting Steel Plate, Sheet, and Strip

ASTM A578: Standard Specification for Straight-Beam Ultrasonic Examination of Rolled Steel Plates for Special Applications

ASTM A923: Standard Test Methods for Detecting Detrimental Intermetallic Phase in Duplex Austenitic/Ferritic Stainless Steels

BSSA 2018: Selection of 316, 304 and 303 types of stainless steels for seawater applications

EN 10088-2: Stainless Steels Technical Delivery Conditions for Sheet/Plate and Strip of Corrosion Resisting Steels for General Purposes

3 Approval of Manufacturers

All materials are to be manufactured at steel works which have been approved by ABS for the type, delivery condition, grade and thickness of stainless steels which are being supplied.

The general requirements of 1-1/2.2 are applicable. Chapter 2, Appendix 1 contains additional requirements for manufacturer's approval of rolled stainless steels.

Rolled stainless steels are to meet the requirements in Chapter 2, Section 1 during production.

4 Manufacturing Process

The steel is to be manufactured by electric-arc, electric-induction, or other suitable melting process and ladle refined. The reduction ratio is to be a minimum of 5 to 1 from continuously cast slab to products, unless it is approved by ABS.

For large diameter round bar, an alternative reduction ratio maybe considered subject to ABS for review.

5 Chemical Composition

Chemical composition is to be tested in accordance with ASTM A751 or equivalent recognized standard. Heat and product analysis are to be reported. Heat analysis is to be taken from the ladle after refining. Product analysis, if required by the standard, is to be taken from the finished product.

The chemical composition is to comply with 2-1/Table 1 of this document or approved specifications for the applicable stainless steel grade.

For the same or similar designations of stainless steels, different standards specify chemical compositions that may vary to some extent. Chemical compositions determined by ABS as marginally outside of the ranges of 2-1/Table 1 of this document can be considered, provided the mechanical and corrosion properties are maintained.

6 Heat Treatment

All materials specified in Chapter 2, Section 1 are to be supplied in the solution treated condition in accordance with the applicable standards and meet the required mechanical properties.

7 Microstructure

If required by the applicable standard or specification, metallography is to be carried out in accordance with an applicable standard. The inspection is to be performed with suitable magnification. The inspection method (refer to ASTM A923) is to be suitable to detect detrimental chromium-rich intermetallic, such as sigma phase, that may reduce the ductility, toughness and corrosion resistance of the alloy.

8 Mechanical Properties

The mechanical properties are to comply with the requirements specified in 2-1/Table 2 for the applicable stainless steel grade.

Notes:

- 1 *Same Heat.* Metal produced by a single cycle of a batch melting process, the product form could be a slab, billet or single ingot.
- 2 *Same Lot.* Pieces of steel, with the same nominal dimensions and from a single heat, which are subsequently heat treated as part of the same continuous operation (or batch). The same nominal dimensions are represent rolled products up to 5 mm (0.2 in.) within the thickness of the test piece.
- 3 *Plates and Wide Flats Greater than 600 mm in Width.* One set of mechanical tests is to include one longitudinal tensile, one transverse tensile and three transverse Charpy V-Notch.
- 4 *Plates and Wide Flats Less than 600 mm in Width.* One set of mechanical tests is to include one longitudinal tensile and three longitudinal Charpy V-Notch.
- 5 *Plates, Sections and Bars.* One set of mechanical tests is to include one longitudinal tensile and three longitudinal Charpy V-Notch.
- 6 *Sheets and Strips.* One tensile test is to be taken in the longitudinal direction. Charpy test is not required unless it is requested.
- 7 *Liquefied Gases Application.* Section 5C-8-6 of the *Marine Vessel Rules*.

8.1 Test Specimens and Procedures

Test specimens and procedures are to be in accordance with the applicable requirements of 2-1-1/11 and 2-3-1/11 of the *ABS Rules for Materials and Welding (Part 2)*, ASTM A370, E10, E23 or other equivalent industry standards, and any additional specific requirements in this Section.

8.2 Test Frequency

Unless otherwise agreed or required, one set of mechanical tests is to be taken per heat per lot, or per 20 tons (40,000 lb), whichever is more stringent.

8.3 Additional Test Frequency

For plates and wide flats for cargo tanks, secondary barriers and pressure vessels of liquefied gas tanks, one set of mechanical properties are to be tested from one end of one plate per heat per lot when the mass and length do not exceed 5 tons (10,000 lb) and 15 meters (50 feet). When the mass or the length exceeds the limits, two sets of mechanical properties are to be tested from both ends of the test plate.

For plates from coils, tension tests are to be made from not less than two coils from each heat, however, the test frequency is to comply with 2-1/8.2, as a minimum. Where a single coil is to be certified, tension test specimens from that coil solely need be tested. Two tension tests are to be made from each coil tested. One tension test specimen is to be obtained from a location immediately prior to the first plate produced and a second test specimen obtained from the approximate center lap from the end of the coil. When the coiled material from one heat differs by 1.6 mm (1/16 in.) or more in thickness, test specimens are to be obtained from both the thinnest and the thickest rolled material. If the coil mass exceeds 20 tons, testing will additionally be required from two locations representing the start and end of the coil.

8.4 Test Specimen Location

Unless otherwise agreed, the location of mechanical test specimens is to be in accordance with the applicable requirements of 2-1-1/11 and 2-3-1/11 of the *ABS Rules for Materials and Welding (Part 2)*, or recognized standards.

Test pieces are to represent the products properties, for example:

- i) Where ingot casting is used, the test pieces are to represent the top of the ingot.
- ii) Test pieces are to be taken from the thickest sections from the same heat and lot. Test results may be used to represent rolled products up to 5 mm (0.2 in.) within the thickness of the test piece.

8.5 Test Temperature

Tensile tests are to be carried out at room temperature, unless it is required by the specification for the tensile properties to be established at a higher or lower temperature, this will depend upon the service requirements.

Charpy V-Notch tests are to be performed at:

- i) -196°C (-320°F) for austenitic stainless steels with the design temperature lower than -105°C (-157°F). For Liquefied Gases application, refer to Section 5C-8-6 of the *Marine Vessel Rules*.
- ii) -20°C (-4°F) or 5°C (41°F) below design temperature for duplex stainless steels, whichever is lower.

9 Corrosion Properties

Unless otherwise agreed, materials are to be subjected to an inter-crystalline corrosion tests to demonstrate that the materials are not susceptible to inter-granular corrosion from precipitation of Chromium-rich carbides at grain boundaries.

One corrosion test is to be carried out for each tensile test according to ISO 3651-2, ASTM A262, Practice E, Copper-Copper Sulphate-Sulphuric Acid or the equivalent recognized standard. The bent samples are to be free from cracks indicating the presence of inter-granular attack and are to pass the visual inspection.

Other corrosion tests such as ASTM G48 for pitting and crevice corrosion, ASTM G78 for crevice corrosion in sea water may be required depending upon the application and heat cycling associated with the heat treatment or repairs.

10 Steel Plates with Specified Minimum Through Thickness Properties

In general, through thickness testing is not performed on 300-series austenitic stainless steels; however, if specified, the requirements of 2-1-1/17 of the *ABS Rules for Materials and Welding (Part 2)* can be applied.

11 Permissible Variations in Dimensions

The requirements for permissible variations in dimensions are defined in 2-1-1/15 and 2-3-1/15 of the *ABS Rules for Materials and Welding (Part 2)*.

For plates, sheets and strips intended for use in the construction of cargo tanks, the negative thickness tolerance is to be in accordance with 2-1-1/8.2, and is not to exceed 0.3 mm (0.012 in.) or 6% under the specified thickness, whichever is less. The average thickness is not to be less than the nominal thickness.

For plates, sheets and strips intended for use in the construction of pressure vessels, a negative thickness tolerance is not allowed.

The tolerances on thickness of sections and bars are to comply with the requirements of a recognized standard.

12 Inspection

Unless otherwise agreed or required, one plate is to be ultrasonically examined per heat per lot in accordance with Specification ASTM A578/A578M, Level B based on continuous scanning over 100% of the plate surface. Other equivalent industry standards may be accepted.

13 Marking, Retests and Rejection

The requirements for marking, retest and rejection are defined in 1-1/6. The finished products are to be clearly marked with the following information:

- AB/Grade or designation, such as AB/304L, AB/2205
- Heat Number or equivalent Number for traceability

If dual certification is requested, all requirements of both grades or designations are to be met and verified.

14 Material Test Report (MTR)

The manufacturer is to provide the required type of material test report giving the following information, as a minimum:

- i) Purchaser's name and order number
- ii) Specifications or grades
- iii) Manufacturing process, for example, melting, casting, rolling, heat treatment, etc.
- iv) Dimensions or thickness
- v) Weight
- vi) Heat Number
- vii) Lot Number
- viii) Chemical composition
- ix) Mechanical properties
- x) Corrosion testing if required
- xi) Nondestructive test if required
- xii) Identification number of piece, including test specimen number where appropriate

TABLE 1
Chemical Composition of Rolled Stainless Steels

| Grade | | Chemical Composition, wt. % ⁽¹⁾⁽⁴⁾ | | | | | | | | | | |
|-----------------------------|-----------------|---|------|------|-------|-------|-----------|----------|-------------------|----|------|-------|
| Type | UNS Designation | C ⁽²⁾ | Si | Mn | P | S | Cr | Ni | Mo ⁽³⁾ | Cu | N | Other |
| Austenitic Stainless Steels | | | | | | | | | | | | |
| 304 | S30400 | 0.070 | 0.75 | 2.00 | 0.045 | 0.030 | 17.5-19.5 | 8.0-10.5 | - | - | 0.10 | - |
| 304L | S30403 | 0.030 | 0.75 | 2.00 | 0.045 | 0.030 | 17.5-19.5 | 8.0-12.0 | - | - | 0.10 | - |

| Grade | | Chemical Composition, wt. % ⁽¹⁾⁽⁴⁾ | | | | | | | | | | |
|---|-----------------|---|------|------|-------|-------|-----------|-----------|-------------------|------|-----------|------------------------|
| Type | UNS Designation | C ⁽²⁾ | Si | Mn | P | S | Cr | Ni | Mo ⁽³⁾ | Cu | N | Other |
| 316 | S31600 | 0.080 | 0.75 | 2.00 | 0.045 | 0.030 | 16.0-18.0 | 10.0-14.0 | 2.00-3.00 | - | 0.10 | - |
| 316L | S31603 | 0.030 | 0.75 | 2.00 | 0.045 | 0.030 | 16.0-18.0 | 10.0-14.0 | 2.00-3.00 | - | 0.10 | - |
| 316LN | S31653 | 0.030 | 0.75 | 2.00 | 0.045 | 0.030 | 16.0-18.0 | 10.0-14.0 | 2.00-3.00 | - | 0.10-0.16 | - |
| 317 | S31700 | 0.080 | 0.75 | 2.00 | 0.045 | 0.030 | 18.0-20.0 | 11.0-15.0 | 3.00-4.00 | - | 0.10 | - |
| 317L | S31703 | 0.030 | 0.75 | 2.00 | 0.045 | 0.030 | 18.0-20.0 | 11.0-15.0 | 3.00-4.00 | - | 0.10 | - |
| 317LN | S31753 | 0.030 | 0.75 | 2.00 | 0.045 | 0.030 | 18.0-20.0 | 11.0-15.0 | 3.00-4.00 | - | 0.10-0.22 | - |
| 321 | S32100 | 0.080 | 0.75 | 2.00 | 0.045 | 0.030 | 17.0-19.0 | 9.0-12.0 | - | - | 0.10 | Ti 5×(C+N)min, 0.70max |
| 347 | S34700 | 0.080 | 0.75 | 2.00 | 0.045 | 0.030 | 17.0-19.0 | 9.0-13.0 | - | - | - | Nb 10×Cmin, 1.00max |
| Ferritic-Austenitic Duplex Stainless Steels | | | | | | | | | | | | |
| - | S31803 | 0.030 | 1.00 | 2.00 | 0.030 | 0.020 | 21.0-23.0 | 4.5-6.5 | 2.5-3.5 | - | 0.08-0.20 | - |
| 2205 | S32205 | 0.030 | 1.00 | 2.00 | 0.030 | 0.020 | 22.0-23.0 | 4.5-6.5 | 3.0-3.5 | - | 0.14-0.20 | - |
| 2507 ⁽⁵⁾ | S32750 | 0.030 | 0.80 | 1.20 | 0.035 | 0.020 | 24.0-26.0 | 6.0-8.0 | 3.0-5.0 | 0.50 | 0.24-0.32 | - |

Notes:

- 1 Maximum, if range or minimum is not indicated.
- 2 Carbon analysis is to be reported to nearest 0.01% except for low-carbon type (0.03% or less), which is to be reported to nearest 0.001%.
- 3 For 316L and 316LN rolled stainless steels to be used in cargo tanks of chemical carriers or stagnant/low flow (less than 1 m/second) sea water, the Mo-content is not to be less than 2.5%.
- 4 Chemical compositions determined by ABS as marginally outside of the ranges can be considered, provided the mechanical and corrosion properties are maintained.
- 5 %Cr + 3.3%Mo + 16%N ≥ 41 represents pitting resistance equivalent.

TABLE 2
Mechanical Property Requirements of Rolled Stainless Steels

| Type | UNS Designation | Tensile Strength, MPa (ksi), Min | Yield Strength, ⁽¹⁾ MPa (ksi), Min | | Elongation, 50 mm (2 in.) gage, %, Min | Hardness, ⁽⁵⁾ HBW (HRB/HRC), Max | Charpy V-Notch | |
|---|-----------------|----------------------------------|---|-------------------|--|---|---------------------------------|-------------------------------|
| | | | R _{p0.2} | R _{p1.0} | | | Min. Average, J (ft-lbf) | Test Temp., °C (°F) |
| Austenitic Stainless Steels | | | | | | | | |
| 304 | S30400 | 515 (75) | 205 (30) | 245 (36) | 40 | 201 HBW (92) HRB | 27 (20) Trans. 41 (30) Long. | -196 (-320) ⁽²⁾⁽³⁾ |
| 304L | S30403 | 485 (70) | 170 (25) | 210 (31) | 40 | 201 HBW (92) HRB | | |
| 316 | S31600 | 515 (75) | 205 (30) | 245 (36) | 40 | 217 HBW (95) HRB | | |
| 316L | S31603 | 485 (70) | 170 (25) | 210 (31) | 40 | 217 HBW (95) HRB | | |
| 316LN | S31653 | 515 (75) | 205 (30) | 245 (36) | 40 | 217 HBW (95) HRB | | |
| 317 | S31700 | 515 (75) | 205 (30) | 245 (36) | 35 | 217 HBW (95) HRB | | |
| 317L | S31703 | 515 (75) | 205 (30) | 245 (36) | 40 | 217 HBW (95) HRB | | |
| 317LN | S31753 | 550 (80) | 240 (35) | 280 (41) | 40 | 217 HBW (95) HRB | | |
| 321 | S32100 | 515 (75) | 205 (30) | 245 (36) | 40 | 217 HBW (95) HRB | | |
| 347 | S34700 | 515 (75) | 205 (30) | 245 (36) | 40 | 201 HBW (92) HRB | | |
| Ferritic-Austenitic Duplex Stainless Steels | | | | | | | | |
| - | S31803 | 620 (90) | 450 (65) | - | 25 | 293 HBW (31) HRC | 27 (20) Trans. 41 (30) Long. | -20 (-4) ⁽⁴⁾ |
| 2205 | S32205 | 655 (95) | 450 (65) | - | 25 | 293 HBW (31) HRC | | |
| 2507 | S32750 | 795 (116) | 550 (80) | - | 15 | 310 HBW (32) HRC | | |

Notes:

- 1 The specified yield strength at both 0.2% and 1.0% are be documented for austenitic stainless steels.
- 2 Charpy tests are required for austenitic stainless steels for materials with design temperatures below -105°C (-157°F). For Liquefied Gases applications, refer to Section 5C-8-6 of the *Marine Vessel Rules*.
- 3 If required by specification or standard, Charpy tests for austenitic stainless steels are to be taken at 5°C (41°F) below design temperature.
- 4 Charpy tests for ferritic-austenitic duplex stainless steels are to be taken at -20°C (-4°F) or 5°C (41°F) below design temperature, whichever is lower.
- 5 Hardness is to be provided for information only.
- 6 For sour service, rolled stainless steel products used in equipment/components are to comply with the applicable part of NACE MR0175/ISO 15156: Materials for use in H_2S containing environment in oil and gas production.

CHAPTER 2 Requirements for Stainless Steels

SECTION 2 Stainless Steel Forgings

1 Scope

The general requirements defined in Sections 2-1-6 and 2-3-7 of the *ABS Rules for Materials and Welding (Part 2)* are to be applied, unless there are specific requirements for stainless steel forgings in this document.

This Section covers the requirements for austenitic and ferritic-austenitic (duplex) stainless steel forgings including:

- i) Manufacturing process
- ii) Chemical composition
- iii) Mechanical properties
- iv) Corrosion properties
- v) Nondestructive testing

Note:

Forgings and forged bars may be produced in ferritic, martensitic and precipitation hardened stainless steels in accordance with the applicable recognized industry standards and submitted to ABS for review.

The requirements in this Section cover stainless steel forgings intended to be used for general marine and offshore applications. Alternatively, forgings which comply with national or proprietary specifications may be accepted, provided such specifications give reasonable equivalence to these requirements.

2 Reference Documents

ASTM A182: Standard Specification for Forged or Rolled Alloy and Stainless Steel Pipe Flanges, Forged Fittings, and Valves and Parts for High-Temperature Service

ASTM A314: Standard Specification for Stainless Steel Billets and Bars for Forging

ASTM A336: Standard Specification for Alloy Steel Forgings for Pressure and High-Temperature Parts

ASTM A388: Standard Practice for Ultrasonic Examination of Steel Forgings

ASTM A473: Standard Specification for Stainless Steel Forgings

ASTM A745: Standard Practice for Ultrasonic Examination of Austenitic Steel Forgings

ASTM A788: Standard Specification for Steel Forgings, General Requirements

ASTM A965: Standard Specification for Steel Forgings, Austenitic, for Pressure and High Temperature Parts

ASTM E165: Standard Practice for Liquid Penetrant Examination for General Industry

NACE MR0175: Materials for use in H₂S-containing environments in oil and gas production

3 Approval of Manufacturers

All materials are to be manufactured at facilities which have been approved by ABS.

Raw materials for forgings such as cast stainless steels or semi-finished products such as billet, bloom etc., are to be manufactured at a facility approved by ABS.

A manufacturing procedure is to be submitted to ABS for approval.

ABS approval is valid for 5 years subjected to annual verification and/or endorsement by the attending Surveyor. The Surveyor is permitted at any time to monitor important aspects of forging production, including but not limited to die preparation and die maintenance, forging temperatures, forging reduction or upset, heat treatment and inspection.

Stainless steel forgings are to meet the applicable requirements in Chapter 2, Section 2 during production.

4 Manufacturing Process

Stainless steels are to be produced by one of the following processes:

- i)* Electric arc-furnace;
- ii)* Electric-induction furnace;
- iii)* Vacuum furnace, or;
- iv)* One of the former followed by vacuum or electroslag-consumable remelting.

Refining and optional separate degassing may be necessary depending on the standard specification applicable to the grade.

Vacuum melting or re-melting processes are not to be specified for nitrogen-stabilized austenitic stainless steel grades, such as Grades 317LN and 316LN.

At the discretion of ABS, Grade 347 is to be stabilization treated, which consists of holding the forging at 815 to 870°C (1500 to 1600°F) for not less than 2.4 min/mm (1 hour/inch) of the thickness and then cooling in the furnace or in still air.

The shaping of forgings or rolled slabs and billets by flame cutting, scarfing or arc-air gouging is to be undertaken in accordance with recognized good practice and is to be carried out before the final heat processing or heat treatment, unless otherwise approved. Preheating is to be employed when necessitated by the composition and/or thickness of the steel. For certain stainless steel components, subsequent machining of all flame cut or arc-air gouging surfaces may be required.

The plastic deformation during forging is to be sufficient as to produce soundness, uniformity of structure and satisfactory mechanical properties after final heat processing or heat treatment. The reduction ratio is to be calculated with reference to the average cross-sectional area of the cast material. Where the cast

material is initially upset, this reference area may be taken as the average cross-sectional area after this operation.

Unless otherwise required and approved, the total reduction ratio is to be at least:

- i)* For forgings made from ingots or from forged blooms or billets, 3:1 where $L > D$ and 1.5:1 where $L \leq D$
- ii)* For forgings made from rolled products, 4:1 where $L > D$ and 2:1 where $L \leq D$
- iii)* For forgings made by upsetting, the length after upsetting is not to be more than one-third of the length before upsetting or, in the case of an initial forging reduction of at least 1.5:1, not more than one-half of the length before upsetting
- iv)* For rolled bars used in lieu of forgings, 6

L and D are the length and diameter, respectively, of the part of the forging under consideration.

A sufficient discard is to be made from each ingot to be free from piping and undue segregation. The forging process is to have ample power to adequately flow the metal within the maximum cross-section of the forging.

When two or more forgings are joined by welding to form a component, the proposed welding procedure specification is to be submitted for approval.

5 Chemical Composition

Chemical composition is to be tested in accordance with ASTM A751 or equivalent recognized standards. Heat and product analysis are to be reported. Heat analysis is to be taken from the ladle after refining. Product analysis, if required by the standard, is to be taken from the finished product.

The chemical composition is to comply with 2-2/Table 1 of this document or approved specifications for the applicable stainless steel grade.

6 Heat Treatment

6.1 General

Heat treatment facilities used in producing ABS certified forgings are to be included in the forge approval including subcontracted heat treatment facilities. Approved subcontracted facilities will be included in the scope of forge approval.

Heat treatment details are to be included in the approval documentation.

Forge qualification is to include all of the heat treatment facilities that the forge will use.

An independent heat treatment facility can obtain approval, provided that it is documented and verified that the facility is capable of producing heat treated products that meet the mechanical properties of the specification and the nondestructive test requirements of the ABS Rules/Guides or applicable standard, and that there is a feedback system to confirm the same during production.

If additional sub-contracted or independent facilities are selected to carry out heat treatment, an ABS approval is to be obtained for the new facility.

The ABS Surveyor is to attend the heat treatment facility during qualification, to verify that the heat treatment process is carried out according to specification.

During production, the extent of monitoring is to be agreed upon with the Surveyor.

A sufficient number of thermocouples are to be connected to the furnace charge to measure and record that its temperature is adequately uniform, unless the temperature uniformity of the furnace can be verified at regular intervals.

Heat treatment is to be carried out in properly constructed furnaces which are efficiently maintained with adequate means to control and record temperature. The furnace dimensions are to be such as to allow the whole furnace charge to be uniformly heated to the necessary temperature. In the case of very large forgings, alternative methods of heat treatment will be specially considered.

The forge is to maintain records of heat treatment, identifying the furnace used, furnace charge, date, temperature and time at temperature, together with the number and location of thermocouples. The records are to be available to the Surveyor upon request.

After forging and before reheating for heat treatment, forgings are to be allowed to cool in a manner to prevent injury and to accomplish transformation.

Upon the completion of forging operations, austenitic and duplex stainless steel forgings are to be solution annealed and quenched in water, oil or a polymer water solution. Direct quenching after completion of forging without subsequent reheating to the temperatures prescribed for the grade is not permissible.

If for any reason a forging is subsequently heated for further hot working, the forging is to be reheat-treated. If a forging is locally reheated or any straightening operation is performed after the final heat treatment, consideration is to be given to a subsequent stress relieving heat treatment with good control to prevent the sensitization of stainless steels.

Note:

Forgings and forged bars in ferritic, martensitic and precipitation hardened stainless steels are to be heat treated in accordance with the standard specification applicable to the grade and are to be submitted to ABS for review.

6.2 Retreatment

The manufacturer may reheat-treat the forging, but not more than three additional times.

7 Mechanical Properties

Test material, sufficient for the required number of tests and for possible retest purposes, is to be provided for each forging or forging lot.

For Liquefied Gases application, the mechanical properties of forgings are to follow the requirements of Section 5C-8-6 of the *Marine Vessel Rules*.

7.1 Tensile and Charpy Properties

The tensile and Charpy properties of forgings are to conform to the requirements of 2-2/Table 2.

7.2 Hardness

Each forging, except those with rough machined weights of less than 113 kg (250 lb), is to be hardness tested to meet the requirements in 2-2/Table 2 of this document, unless the applicable standard requires hardness test irrespective of weight.

For sour service, stainless steel forgings used in equipment or components are to comply with the applicable part of NACE MR0175/ISO 15156: *Materials for use in H₂S containing environment in oil and gas production*.

7.3 Test Procedure and Specimens

Test specimens and procedures are to be in accordance with the applicable requirements of 2-1-1/11 and 2-3-1/11 of the ABS *Rules for Materials and Welding (Part 2)*, ASTM A370, E10, E23 or other equivalent industry standards. Specific requirements in this Section supersede industry Standards.

7.3.1 Location and Orientation of Specimens

Mechanical properties are to be determined from tensile test specimens taken from prolongations having a sectional area not less than the body of the forging. The length of the prolongation is to be such that the distance from the test specimen mid-gauge to the end of the prolongation is to be 89 mm (3.5 in.) or one-half the forging section thickness or diameter, whichever is more. The tensile test specimens may be taken in a direction parallel to the axis of the forging in the direction in which the metal is most drawn out. In lieu of axial tests, test specimens may be taken tangentially or radially to the axes of the forging with the agreement of ABS. The test specimens are to be located at any point midway between the center and the surface of solid forgings and at any point midway between the inner and outer surfaces of the wall of hollow forgings.

Notes:

- 1 Longitudinal: The axis of the test piece is parallel to the principal direction of forging product.
- 2 Tangential/Radial: The axis of the test piece is tangential to the principal direction of the forging product.

7.3.2 Alternative Tests Specimens and Hollow-drilled Specimens

In lieu of prolongations, subject to the Surveyor's agreement, the test specimens may be taken as follows.

- i) A sacrificial forging product per heat per lot
- ii) A forged qualification test coupon representative of the actual forged products in terms of size, chemistry, forging ratio and heat treatment cycle
- iii) A test specimen may be taken from forgings with a hollow drill, provided the drill hole will not be detrimental to the final product

7.3.3 Very Small Forgings

In the cases of very small forgings weighing less than 113 kg (250 lb) each, where the foregoing procedures are impractical, a special forging may be made for the purpose of obtaining test specimens, provided the Surveyor is satisfied that these test specimens are representative of the forgings submitted for test. In such cases, the special forgings are to have the same chemistry, same amount of working and reduction as the forgings represented and is to be heat-treated with those forgings.

7.3.4 Identification of Specimens

Forgings and test materials are to be heat treated together in the same furnace, and quenched in the same bath/tank.

The test specimens are not to be detached from the forgings until the final heat treatment of the forgings has been completed and test specimens have been stamped by the Surveyor for identification. Where the material identification system of the manufacturer is found acceptable to ABS and is maintained in that condition through initial and periodical verification by ABS, it may be considered in lieu of stamping by the Surveyor before detachment.

In case of the qualification test coupon as per 2-2/7.3.2ii., the test coupon identification is to be the same as the forgings and full traceability is to be maintained to the satisfaction of the Surveyor.

7.4 Test Frequency and Position

Unless otherwise agreed or required, the test frequency and position are to be defined as follows.

7.4.1 Tension Tests

- i) *Large Forgings.* In the case of large forgings with rough machined weights of 3180 kg (7000 lb) or over, one tension test is to be taken from each end of the forging. In the case of ring or hollow cylindrical forgings, the tests may be taken 180 degrees apart from the same end of the forging.
- ii) *Intermediate-Sized Forgings.* In the case of forgings with rough machined weights less than 3180 kg. (7000 lb), except as noted in the following paragraph, at least one tension test is to be taken from each forging.
- iii) *Small Forgings.* In the case of small forgings with weight at time of heat treatment less than 1000 kg (2200 lb) and one tension test specimen may be taken from one forging as representative of a lot, provided the forgings in the lot are of a similar size, are of one grade and kind only, are made from the same heat and are heat-treated in the same furnace charge. The total mass of the furnace charge is not to exceed 6000 kg (13200 lb).
- iv) *Sleeves, Couplings and Nut Forgings.* In the case of ring-type or cylinder-type forgings for use as sleeves, coupling or nuts, the tension test is to be taken from a full-size prolongation left on one end of each individual forging. Test specimens are to be in a longitudinal orientation at mid-wall of the ring or cylinder as close as practical to the end of the rough machined surface of the forging.
- v) *Continuous Heat Treatment.* Whereby a furnace incorporates a method of controlled moving of the component from the charging end, through the furnace at a predetermined temperature and time, to the discharging end. Test coupon sampling procedures are to be specially agreed with ABS.

7.4.2 Hardness Tests

- i) *Large, Intermediate and Small Sized Forgings.* Each forging, except those with rough machined weights of less than 113 kg (250 lb), is to be hardness tested to meet the requirements of 2-2/Table 2. Forgings are to be tested at locations 180 degrees apart on each end.
- ii) *Discs, Rings and Hollow Forgings.* Each forging except, those with rough machined weights of less than 113 kg (250 lb), is to be hardness tested to meet the requirements of 2-2/Table 2. Forgings are to be tested at the approximate mid-radius and 180 degrees apart on each flat surface of the forging; the testing locations on opposite sides are to be offset by 90 degrees.
- iii) *Very Small Forgings.* In cases of involving very small forgings weighing less than 113 kg (250 lb) each, the hardness tests may be made from broken tension test specimens, or on a special forging representing the lot.
- iv) Hardness tests in other locations may be specified and required by an applicable standard.

7.5 Test Temperature

Tensile tests are to be carried out at room temperature, unless it is required for the tensile properties to be established at a higher or lower temperature.

Charpy V-Notch tests are to be performed at:

- i) -196°C (-320°F) for austenitic stainless steels with the design temperature lower than -105°C (-157°F). For Liquefied Gases application, refer to Section 5C-8-6 of the *Marine Vessel Rules*.
- ii) -20°C (-4°F) or 5°C (41°F) below design temperature for duplex stainless steels, whichever is lower.

8 Corrosion Properties

Depending upon application or requirements in specification or standard, inter-granular corrosion testing of stainless steel forgings is to be agreed between purchaser and supplier.

Where inter-granular corrosion properties are required, materials are to be subjected to an inter-crystalline corrosion test to demonstrate that the materials are not susceptible to inter-granular corrosion from precipitation of chromium-rich carbides at grain boundaries.

One corrosion test is to be carried out for each tensile test according to ISO 3651-2, ASTM A262, Practice E, Copper-Copper Sulphate-Sulphuric Acid or the equivalent recognized standard. The bent samples are to be free from cracks indicating the presence of inter-granular attack and are to pass the visual inspection.

Other corrosion tests such as ASTM G48 for pitting and crevice corrosion, ASTM G78 for crevice corrosion in sea water may be required depending upon the application and heat cycling associated with the heat treatment or repairs.

9 Inspection

The general requirements defined in Appendix 2-A7 of the *ABS Rules for Materials and Welding (Part 2)* are to be applied.

After final heat treatment, all forgings are to be examined by the Surveyor and should be free from defects. The finish is to be free of scale, cracks, seams, laps, fins, cold shuts, laminations, nicks, gouges, pipe, shrinkage, porosity and burst indications.

Surface inspection is to be performed using liquid penetrant examination in accordance with a recognized standard such as ASTM E165.

Ultrasonic volumetric inspection is to be tested in accordance with a recognized standard such as ASTM A388 or A745.

If radiography is applied, it is to be carried out in accordance with a recognized standard or practice for radiography of stainless steels.

10 Rectification of Defective Forgings

Defects may be removed by grinding or chipping and grinding, provided that the component dimensions remain acceptable. The resulting grooves are to have a bottom radius of approximately three times the groove depth and are to be blended into the surrounding surface so as to avoid any sharp contours. Complete elimination of the defective material is to be verified by liquid penetrant testing.

In certain applications, weld repair of stainless steel forgings may be prohibited.

Repair welding of forgings, if permitted, is to have prior approval by ABS. In such cases, full details of the extent and location of the repair, the proposed welding procedure, heat treatment and subsequent inspection procedures are to be submitted for approval.

Weld procedures for all types of welds are to be appropriately qualified to the satisfaction of the attending Surveyor.

Before undertaking the repair welding of forgings the manufacturer is to prove to the satisfaction of the Surveyor that the welders or welding operators are duly qualified for the work intended.

The forging manufacturer is to maintain records of repairs and subsequent inspections that are traceable to each forging repaired. The records are to be presented to the Surveyor on request.

Temporary welds made for operations such as lifting, handling and staging are to be carried out according to qualified welding procedures and qualified welders/operators and are to be removed, ground and inspected using suitable approved, nondestructive examination methods.

Depending upon the application or specific requirements in the purchase order, inter-granular corrosion testing of weld repaired stainless steel forgings maybe be required subject to the agreement between purchaser and supplier.

11 Identification, Marking, Retests and Rejection

Marking, retests and rejection requirements are to comply with 1-1/6.

11.1 Identification

The manufacturer is to adopt a system of identification which will enable forgings to be traced to the original cast at any point during production, and the Surveyor is to be given full facilities for tracing the forgings, when required.

11.2 Retests

With reference to 1-1/6.2, if satisfactory results are obtained from both of the additional tests, the forging or batch of forgings is acceptable. If one or both retests fail, the forging or batch of forgings is to be rejected. The manufacturer may reheat-treat forgings that have failed. After reheat-treating, the forgings are to be submitted for all mechanical testing and meet the requirements in accordance with 2-2/Table 2.

11.3 Marking

In addition to appropriate identification markings of the manufacturer ABS markings, indicating satisfactory compliance with the requirements and as furnished to the Surveyor, are to be stamped on all forgings in such locations as to be discernible after machining and installation. In addition, the stainless steel grade is to be stamped, for example, AB/304, AB/304L, AB/316L, and AB/2205.

11.4 Rejection

Any forging that has injurious discontinuities observed prior to or subsequent to acceptance at the manufacturer's plant is to be subject to rejection.

12 Material Test Report (MTR)

The manufacturer is to provide the required type of materials test report giving the following particulars for each forging or batch of forgings which has been accepted.

- i)* Purchaser's name and order number
- ii)* Description of forgings and steel quality
- iii)* Identification number
- iv)* Steelmaking process, cast number and chemical analysis of ladle sample
- v)* Results of mechanical tests
- vi)* Results of corrosion tests, if required
- vii)* Results of nondestructive tests, if applicable
- viii)* Details of heat treatment, including temperature and holding times
- ix)* Specification

TABLE 1
Chemical Composition of Stainless Steel Forgings

| Grade | | | Chemical Composition, wt. % ⁽¹⁾⁽⁴⁾ | | | | | | | | | | |
|---|-----------------|------------|---|------|------|-------|-------|-----------|-----------|-------------------|-----|-----------|------------------------------|
| Type | UNS Designation | ASTM Grade | C ⁽²⁾ | Si | Mn | P | S | Cr | Ni | Mo ⁽³⁾ | Cu | N | Other |
| Austenitic Stainless Steels | | | | | | | | | | | | | |
| 304 | S30400 | F304 | 0.080 | 1.00 | 2.00 | 0.045 | 0.030 | 18.0-20.0 | 8.0-11.0 | - | - | - | - |
| 304L | S30403 | F304L | 0.030 | 1.00 | 2.00 | 0.045 | 0.030 | 18.0-20.0 | 8.0-13.0 | - | - | 0.10 | - |
| 316 | S31600 | F316 | 0.080 | 1.00 | 2.00 | 0.045 | 0.030 | 16.0-18.0 | 10.0-14.0 | 2.00-3.00 | - | - | - |
| 316L | S31603 | F316L | 0.030 | 1.00 | 2.00 | 0.045 | 0.030 | 16.0-18.0 | 10.0-15.0 | 2.0-3.0 | - | 0.10 | - |
| 316LN | S31653 | F316LN | 0.030 | 1.00 | 2.00 | 0.045 | 0.030 | 16.0-18.0 | 11.0-14.0 | 2.00-3.00 | - | 0.10-0.16 | - |
| 317L | S31703 | F317L | 0.030 | 1.00 | 2.00 | 0.045 | 0.030 | 18.0-20.0 | 11.0-15.0 | 3.00-4.00 | - | - | - |
| 321 | S32100 | F321 | 0.080 | 1.00 | 2.00 | 0.045 | 0.030 | 17.0-19.0 | 9.0-12.0 | - | - | - | Ti5×(C+N) min, 0.70max |
| 347 | S34700 | F347 | 0.080 | 1.00 | 2.00 | 0.045 | 0.030 | 17.0-20.0 | 9.0-13.0 | - | - | - | - |
| Ferritic-Austenitic Duplex Stainless Steels | | | | | | | | | | | | | |
| - | S31803 | F51 | 0.030 | 1.00 | 2.00 | 0.035 | 0.015 | 21.0-23.0 | 4.5-6.5 | 2.5-3.5 | - | 0.10-0.20 | - |
| 2205 | S32205 | F60 | 0.030 | 1.00 | 2.00 | 0.030 | 0.020 | 22.0-23.0 | 4.5-6.5 | 3.0-3.5 | - | 0.14-0.20 | - |
| 2507 ⁽⁵⁾ | S32750 | F53 | 0.030 | 0.80 | 1.20 | 0.035 | 0.020 | 24.0-26.0 | 6.0-8.0 | 3.0-5.0 | 0.5 | 0.24-0.32 | - |

Notes:

- 1 Maximum, if range or minimum is not indicated.
- 2 Carbon analysis is to be reported to nearest 0.01% except for low-carbon type (0.03% or less), which is to be reported to nearest 0.001%.
- 3 For 316L and 316LN stainless steel forgings to be used in cargo tanks of chemical carriers or stagnant/low flow (less than 1 m/second) sea water, the Mo-content is not to be less than 2.5%.
- 4 Chemical compositions determined by ABS to be marginally outside of the ranges can be considered, provided the mechanical and corrosion properties are maintained.
- 5 %Cr + 3.3%Mo + 16%N ≥ 41, represents pitting resistance equivalent.

TABLE 2
Mechanical Property Requirements of Stainless Steel Forgings

| Grade | | | Tensile Strength, MPa (ksi), Min | Yield Strength, ⁽¹⁾ MPa (ksi), Min $R_{p0.2}$ | Elongation, 50 mm (2 in.) gage, %, Min | Reduction of Area, %, Min | Hardness, ^(5,7) HBW (HRB/HRC), Max | Charpy V-Notch | |
|---|-----------------|--------------------|----------------------------------|--|--|---------------------------|---|---------------------------------|------------------------------|
| Type | UNS Designation | ASTM Grade | | | | | | Min. Average, J (ft-lbf) | Test Temp., °C (°F) |
| Austenitic Stainless Steels | | | | | | | | | |
| 304 | S30400 | F304 | 485 (70) | 205 (30) | 30 | 45 | 201 HBW (92) HRB | 27 (20) Trans. 41 (30) Long. | -196 (-320) ^(2,3) |
| 304L | S30403 | F304L | 450 (65) | 170 (25) | 30 | 45 | 201 HBW (92) HRB | | |
| 316 | S31600 | F316 | 485 (70) | 205 (30) | 30 | 45 | 217 HBW (95) HRB | | |
| 316L | S31603 | F316L | 450 (65) | 170 (25) | 30 | 45 | 217 HBW (95) HRB | | |
| 316LN | S31653 | F316LN | 515 (75) | 205 (30) | 30 | 45 | 217 HBW (95) HRB | | |
| 317L | S31703 | F317L | 450 (65) | 170 (25) | 30 | 45 | 217 HBW (95) HRB | | |
| 321 | S32100 | F321 | 515 (75) | 205 (30) | 30 | 45 | 217 HBW (95) HRB | | |
| 347 | S34700 | F347 | 485 (70) | 205 (30) | 30 | 45 | 217 HBW (95) HRB | | |
| Ferritic-Austenitic Duplex Stainless Steels | | | | | | | | | |
| - | S31803 | F51 | 620 (90) | 450 (65) | 25 | 45 | 293 HBW (31) HRC | 27 (20) Trans. 41 (30) Long. | -20 (-4) ⁽⁴⁾ |
| 2205 | S32205 | F60 | 655 (95) | 450 (65) | 25 | 45 | 293 HBW (31) HRC | | |
| 2507 | S32750 | F53 ⁽⁶⁾ | 800 (116) | 550 (80) | 15 | - | 310 HBW (32) HRC | | |

Notes:

- 1 The specified yield strength at both 0.2% and 1.0% are to be documented for austenitic stainless steels.
- 2 Charpy tests are required for austenitic stainless steels for materials with design temperatures below -105°C (-157°F). For Liquefied Gases applications, refer to Section 5C-8-6 of the *Marine Vessel Rules*.
- 3 If required by specification or standard, Charpy tests for austenitic stainless steels are to be taken at 5°C (41°F) below design temperature.
- 4 Charpy tests for ferritic-austenitic duplex stainless steels are to be taken at -20°C (-4°F) or 5°C (41°F) below design temperature, whichever is lower.
- 5 In general, Hardness values are target values. The maximum hardness values may be mandatory if it is required by specification or application.
- 6 Brinell Hardness for F53 is to be 310 max.
- 7 For sour service, stainless steel forgings used in equipment/components are to comply with the applicable part of NACE MR0175/ISO 15156: Materials for use in H_2S containing environment in oil and gas production.

CHAPTER 2 Requirements for Stainless Steels

SECTION 3 Stainless Steel Castings

1 Scope

The general requirements defined in Sections 2-1-5 and 2-3-9 of the *ABS Rules for Materials and Welding (Part 2)* are to be applied, unless there are specific requirements for stainless steel castings in this document.

This Section covers the requirements for austenitic and ferritic-austenitic (duplex) stainless steel castings.

- i)* Manufacturing process
- ii)* Chemical composition
- iii)* Mechanical properties
- iv)* Corrosion properties
- v)* Nondestructive test

Note:

Castings may be produced in ferritic, martensitic and precipitation-hardened stainless steels in accordance with the applicable recognized industry standards and submitted to ABS for review.

The requirements in this Section cover stainless steel castings intended to be used for general marine and offshore applications. Alternatively, castings which comply with national or proprietary specifications may be accepted, provided such specifications give reasonable equivalence to these requirements.

For application of stainless steels in propeller casting, reference is to be made to Section 2-3-15 of the *ABS Rules for Materials and Welding (Part 2)* and Appendix 7-A-10 of the *ABS Rules for Survey after Construction (Part 7)*.

2 Reference Documents

ASTM A297: Standard Specification for Steel Castings, Iron-Chromium and Iron-Chromium-Nickel, Heat Resistant, for General Application

ASTM A351: Standard Specification for Castings, Austenitic, Austenitic-Ferritic (Duplex), for Pressure Containing Parts

ASTM A488: Practice for Steel Castings, Welding, Qualification of Procedures and Personnel

ASTM A609: Standard Practice for Castings, Carbon, Low-Alloy, and Martensitic Stainless Steel, Ultrasonic Examination Thereof

ASTM A703: Standard Specification for Steel Castings, General Requirements, for Pressure-Containing Parts

ASTM A743: Standard Specification for Castings, Iron-Chromium, Iron-Chromium-Nickel, Corrosion Resistant, for General Application

ASTM A744: Standard Specification for Castings, Iron-Chromium-Nickel, Corrosion Resistant, for Severe Service

ASTM E165: Standard Test Method for Liquid Penetrant Examination

NACE MR0175: Materials for use in H₂S-containing environments in oil and gas production

3 Approval of Manufacturers

All materials are to be manufactured at facilities which have been approved by ABS.

If a foundry elects to purchase cast materials from other facilities, those facilities are to be approved by ABS.

A manufacturing procedure is to be submitted to ABS for approval.

The Surveyor is permitted at any time to monitor important aspects of casting production, including but not limited to mold preparation and chaplet positioning, pouring times and temperatures, mold breakout, repairs, heat treatment and inspection.

Stainless steel castings are to meet the applicable requirements in Chapter 2, Section 3 during production.

4 Manufacturing Process

The stainless steels are to be produced by one of the following processes:

- i)* Electric arc-furnace
- ii)* Electric-induction furnace
- iii)* Vacuum furnace, or
- iv)* One of the former followed by vacuum or electroslag-consumable remelting

Refining and optional separate degassing may be necessary depending on the standard specification applicable to the grade.

At the discretion of ABS, Grade 347 is to be stabilization treated, which consists of holding the forging at 815 to 870°C (1500 to 1600°F) for not less than 2.4 min/mm (1 hour/inch) of the thickness and then cooling in the furnace or in still air.

For stainless steel casting flame cutting, scarfing or arc-air gouging is to be undertaken in accordance with recognized good practices and is to be carried out before the final heat processing or heat treatment, unless otherwise approved. Preheating is to be employed when necessitated by the composition and/or thickness of the steel. For certain components, subsequent machining of all flame cut or arc-air gouging surfaces may be required.

When two or more castings are joined by welding to form a component, the proposed welding procedure specification is to be submitted for approval.

5 Chemical Composition

Chemical composition is to be tested in accordance with ASTM A751 or an equivalent recognized standard. Heat and product analysis are to be reported. Heat analysis is to be taken from the ladle after refining. Product analysis, if required by the standard, is to be taken from the finished product.

The chemical composition is to comply with 2-3/Table 1 of this document or approved specifications for the applicable stainless steel grade.

6 Heat Treatment

6.1 General

Heat treatment facilities used in producing ABS certified castings are to be included in the foundry approval including subcontracted heat treatment facilities. Approved subcontracted facilities will be included in the scope of foundry approval.

Heat treatment details are to be included in the approval documentation.

Foundry qualification is to include all of the heat treatment facilities that the castings will use.

An independent heat treatment facility can obtain approval, provided that it is documented and verified that the facility is capable of producing heat treated products that meet the mechanical properties of the specification and the nondestructive test requirements of the ABS Rules/Guides or applicable standard, and that there is a feedback system to confirm the same during production.

If additional sub-contracted or independent facilities are selected to carry out heat treatment, an ABS approval is to be obtained for the new facility.

The ABS Surveyor is to attend the heat treatment facility during qualification to verify that the heat treatment process is carried out according to specification.

During production, the extent of monitoring is to be agreed with the Surveyor.

A sufficient number of thermocouples are to be connected to the furnace charge to measure and record that its temperature is adequately uniform, unless the temperature uniformity of the furnace can be verified at regular intervals.

Heat treatment is to be carried out in properly constructed furnaces which are efficiently maintained with adequate means to control and record temperature. The furnace dimensions are to be such as to allow the whole furnace charge to be uniformly heated to the necessary temperature. In the case of very large castings, alternative methods of heat treatment will be specially considered.

The foundry is to maintain records of heat treatment, identifying the furnace used, furnace charge, date, temperature and time at temperature, together with the number and location of thermocouples. The records are to be available to the Surveyor upon request.

After casting and before reheating for heat treatment, castings are to be allowed to cool in a manner that prevents injury and accomplishes transformation.

Upon completion of casting operations, austenitic and duplex stainless steel castings are to be solution annealed and quenched in water, oil or a polymer water solution. Direct quenching after completion of casting without subsequent reheating to the temperatures prescribed for the grade is not permissible.

If for any reason a casting is subsequently heated for further hot working, the casting is to be re-heat-treated. If a casting is locally reheated or any straightening operation is performed after the final heat treatment, consideration is to be given to a subsequent stress relieving heat treatment with good control to prevent the sensitization of stainless steels.

Note:

Casting in ferritic, martensitic and precipitation hardened stainless steels are to be heat treated in accordance with the standard specification applicable to the grade and are to be submitted to ABS for review.

6.2 Retreatment

The manufacturer may re-heat-treat the casting, but not more than three additional times.

7 Mechanical Properties

Test material, sufficient for the required number of tests and for possible retest purposes, is to be provided for each casting or casting lot.

For Liquefied Gases application, the mechanical properties of castings are to follow the requirements of Section 5C-8-6 of the *Marine Vessel Rules*.

For application of stainless steels in propeller casting, reference is to be made to Section 2-3-15 of the *ABS Rules for Materials and Welding (Part 2)* and Appendix 7-A-10 of the *ABS Rules for Survey after Construction (Part 7)*.

7.1 Tensile and Charpy Properties

The casting tensile and Charpy properties are to conform to the requirements of 2-3/Table 2.

7.2 Hardness

Hardness tests may need to be performed depending upon the requirements of the applicable standard or specification.

Stainless steel castings equipment/components, designed to be used for sour service, are to comply with the applicable part of NACE MR0175/ISO 15156: Materials for use in H₂S-containing environments in oil and gas production.

7.3 Test Procedure and Specimens

Test specimens and procedures are to be in accordance with the applicable requirements of 2-1-1/11 and 2-3-1/11 of the *ABS Rules for Materials and Welding (Part 2)*, ASTM A370, E10, E23 or other equivalent industry standards, unless there are specific requirements in this Section.

7.3.1 Material Coupons

Castings and test materials are to be heat treated together in the same furnace, and quenched in the same bath/tank.

Test material, sufficient for the required number of tests and for possible retest purposes, is to be provided for each casting or casting lot. The physical properties are to be determined from test specimens prepared from coupons which, except as specified in 2-3-9/11.3 of the *ABS Rules for Materials and Welding (Part 2)*, are to be cast integral with the casting to be inspected. When this is impracticable, the coupons may be cast with and gated to the casting and are to have a thickness of not less than the critical controlling cross section thickness of the casting or 30 mm (1.2 in.), whichever is greater. In any case, these coupons are not to be detached until the heat treatment of the castings has been completed, nor until the coupons have been stamped by the Surveyor for identification. Where the material identification system of the manufacturer is found acceptable to ABS and is maintained in that condition through initial and periodical verification by ABS, it may be considered in lieu of stamping by the Surveyor before detachment.

Where the casting finished mass exceeds 10,000 kg (22,000 lb) or is of complex design, two test samples are to be provided. Where large castings are made from two or more casts which are not

from the same pour, two or more test samples are to be provided, corresponding to the number of casts involved. The samples are to be integrally cast at locations as widely separated as possible.

Note:

The controlling cross section thickness is the diameter of the largest theoretical sphere which can be inscribed within the critical section of the casting.

7.3.2 Separately Cast Coupons

In the case of small castings having an estimated weight of less than 907 kg (2000 lb), each of the coupons may be cast separately, provided the Surveyor is furnished an affidavit by the manufacturer stating that the separately cast coupons were cast from the same heat as the castings represented and that they were heat-treated with the castings.

7.3.3 Identification of Specimens

The test specimens are not to be detached from the castings until the final heat treatment of the castings has been completed and test specimens have been stamped by the Surveyor for identification. Where the material identification system of the manufacturer is found acceptable to ABS and is maintained in that condition through initial and periodical verification by ABS, it may be considered in lieu of stamping by the Surveyor before detachment.

In case of the qualification test coupon as per 2-3/7.3.2, the test coupon identification is to be the same as the castings and full traceability is to be maintained to the satisfaction of the Surveyor.

7.4 Test Frequency

Unless otherwise agreed or required, at least one set of mechanical properties is to be taken per heat per lot, except where two or more sets of samples are required as indicated in 2-3-9/11.1 of the *ABS Rules for Materials and Welding (Part 2)*.

Notes:

- 1 One set of mechanical properties is to include one tensile and three Charpy V-Notch;
- 2 For Liquefied Gases application, the mechanical properties are to follow the requirements of Section 5C-8-6 of the *Marine Vessel Rules*.

7.5 Test Temperature

Tensile tests are to be carried out at room temperature, unless it is required for the tensile properties to be established at a higher or lower temperature.

Charpy V-Notch tests are to be performed at:

- i) -196°C (-320°F) for austenitic stainless steels with the design temperature lower than -105°C (-157°F). For Liquefied Gases application, refer to Section 5C-8-6 of the *Marine Vessel Rules*.
- ii) -20°C (-4°F) or 5°C (41°F) below design temperature for duplex stainless steels, whichever is lower.

8 Corrosion Properties

Depending upon the application or requirements in specification or standard, inter-granular corrosion testing of stainless steel castings are to be agreed upon between the purchaser and supplier.

Where inter-granular corrosion properties are required, materials are to be subjected to inter-crystalline corrosion testing to demonstrate that the materials are not susceptible to inter-granular corrosion from precipitation of chromium-rich carbides at grain boundaries.

One corrosion test is to be carried out for each tensile test according to ISO 3651-2, ASTM A262, Practice E, Copper-Copper Sulphate-Sulphuric Acid or the equivalent recognized standard. The bent samples are to be free from cracks indicating the presence of inter-granular attack and are to pass the visual inspection.

Other corrosion tests such as ASTM G48 for pitting and crevice corrosion and ASTM G78 for crevice corrosion in sea water may be required, depending upon the application and heat cycling associated with the heat treatment or repairs.

9 Inspection

9.1 General

All castings are to be examined by the Surveyor after final heat treatment and thorough cleaning to confirm that the castings are free from defects. Where applicable internal surfaces are to be inspected, surfaces are not to be hammered or peened or treated in any way which may obscure defects.

In the event of a casting proving to be defective during subsequent machining or testing, it is to be rejected, notwithstanding any previous certification.

The manufacturer is to verify that all dimensions meet the specified requirements. The Surveyor is to spot check key dimensions to confirm the manufacturer's recorded dimensions.

When required, castings are to be pressure tested before final acceptance. The tests are to be carried out in the presence and to the satisfaction of the attending Surveyor.

9.2 Nondestructive Test

Appendix 2-A6 of the *ABS Rules for Materials and Welding (Part 2)* is regarded as an example of an acceptable standard. Additional NDE is to be considered at chaplet locations and areas of expected defects.

Depending on the application, appropriate nondestructive testing is also to be carried out before acceptance and the results are to be reported by the manufacturer. The extent of testing and acceptance criteria are to be agreed with ABS.

Surface inspection is to be performed using liquid penetrant examination in accordance with a recognized standard such as ASTM E165.

Ultrasonic volumetric inspection is to be carried out in accordance with a recognized standard such as ASTM A609.

If radiography is applied, it is to be carried out in accordance with a recognized standard or practice for radiography of stainless steels.

At least one casting is to be subject to liquid penetrant inspection and/or ultrasonic inspection per heat per lot.

9.3 Minor Defects

Defects are to be considered minor when the cavity prepared for welding has a depth not greater than 20% of the actual wall thickness, but in no case greater than 25 mm (1 in.), and has no lineal dimension greater than four times the wall thickness nor greater than 150 mm (6 in.). Shallow grooves or depressions resulting from the removal of defects may be accepted, provided that they will cause no appreciable reduction in the strength of the casting. The resulting grooves or depressions are to be subsequently ground smooth, and complete elimination of the defective material is to be verified by liquid penetrant. Repairs of minor defects where welding is required are to be treated as weld repairs and repaired in accordance with an approved procedure. Minor defects in critical locations are to be treated as and repaired in the same manner as major defects.

9.4 Major Defects

With ABS approval, defects other than minor defects may be repaired by welding using an approved procedure.

10 Rectification of Defective Castings

Defects may be removed by grinding or chipping and grinding, provided that the component dimensions remain acceptable. The resulting grooves are to have a bottom radius of approximately three times the groove depth and are to be blended into the surrounding surface so as to avoid any sharp contours. Complete elimination of the defective material is to be verified by liquid penetrant testing.

Repair welding of castings, if permitted, is to have prior approval by ABS. In such cases, full details of the extent and location of the repair, the proposed welding procedure, heat treatment and subsequent inspection procedures are to be submitted for approval.

Weld procedures for all types of welds are to be appropriately qualified to the satisfaction of the attending Surveyor.

Before undertaking the repair welding of castings, the manufacturer is to prove to the satisfaction of the Surveyor that the welders or welding operators are duly qualified for the work intended.

The casting manufacturer is to maintain records of repairs and subsequent inspections that are traceable to each casting repaired. The records are to be presented to the Surveyor on request.

Temporary welds made for operations such as lifting, handling, staging, etc., are to be carried out to qualified welding procedures and qualified welders/operators and are to be removed, ground and inspected using suitable approved, nondestructive examination methods.

Depending upon the application or requirements in the specification or standard, inter-granular corrosion testing of weld repaired stainless steel castings maybe be required subject to the agreement between purchaser and supplier.

11 Identification, Marking, Retests and Rejection

11.1 Identification

The manufacturer is to adopt a system of identification which will enable castings to be traced to the original cast at any point during production, and the Surveyor is to be given full facilities for tracing the castings, when required.

11.2 Retests

If the results of the mechanical tests for any casting or any lot of castings do not conform to the requirements specified, two additional test samples representative of the casting or casting batch are to be taken in accordance with 1-1/6.2. If satisfactory results are obtained from both of the additional tests, the casting or batch of castings is acceptable. If one or both retests fail, the casting or batch of castings is to be rejected. The manufacturer may reheat treat castings that have failed. After reheat-treating, test samples from the casting are to be submitted for all mechanical testing again and must meet test requirements in accordance with 2-3/Table 2.

11.3 Marking

In addition to appropriate identification markings of the manufacturer, ABS markings, indicating satisfactory compliance with the requirements and as furnished by the Surveyor, are to be stamped on all castings in such locations as to be discernible after machining and installation. In addition, the stainless steel grade is to be stamped such as AB/304, AB/304L, AB/316L, AB/2205, etc.

11.4 Rejection

Any casting having injurious discontinuities that are observed prior to or subsequent to acceptance at the manufacturer's plant will be rejected.

12 Material Test Report (MTR)

The manufacturer is to provide the required type of materials test report giving the following particulars for each casting or batch of castings which has been accepted as follows:

- i) Purchaser's name and order number
- ii) Description of castings and steel quality
- iii) Identification number
- iv) Steelmaking process, cast number and chemical analysis of ladle sample
- v) Results of mechanical tests
- vi) Results of corrosion tests, if required
- vii) Results of nondestructive tests, if applicable
- viii) Details of heat treatment, including temperature and holding times
- ix) Where applicable, test pressure
- x) Specification

TABLE 1
Chemical Composition of Stainless Steel Castings

| Grade | | | Chemical Composition, wt. % ⁽¹⁾⁽⁴⁾ | | | | | | | | | | |
|---|--------|-------------|---|------|------|-------|-------|---------------|--------------|-------------------|----|---|---------------------------|
| Type | UNS | Cast Grade | C ⁽²⁾ | Si | Mn | P | S | Cr | Ni | Mo ⁽³⁾ | Cu | N | Other |
| Austenitic Stainless Steels | | | | | | | | | | | | | |
| 304 | J92600 | CF8 CF8A | 0.080 | 2.00 | 1.50 | 0.040 | 0.030 | 18.0- 21.0 | 8.0- 11.0 | 0.50 | - | - | - |
| 304L | J92500 | CF3 CF3A | 0.030 | 2.00 | 1.50 | 0.040 | 0.030 | 17.0- 21.0 | 8.0- 12.0 | 0.50 | - | - | - |
| 316 | J92900 | CF8M | 0.080 | 1.50 | 1.50 | 0.040 | 0.030 | 17.0- 21.0 | 9.0- 13.0 | 2.00- 3.00 | - | - | - |
| 316L | J92800 | CF3M | 0.030 | 1.50 | 1.50 | 0.040 | 0.030 | 17.0- 21.0 | 9.0- 13.0 | 2.00- 3.00 | - | - | - |
| 317 | J93000 | CG8M | 0.080 | 1.50 | 1.50 | 0.040 | 0.030 | 18.0- 21.0 | 9.0- 13.0 | 3.00- 4.00 | - | - | - |
| 317L | J92288 | CG3M | 0.030 | 1.50 | 1.50 | 0.040 | 0.030 | 18.0- 21.0 | 9.0- 13.0 | 3.00- 4.00 | - | - | - |
| 347 | J92710 | CF8C | 0.080 | 2.00 | 1.50 | 0.040 | 0.030 | 18.0- 21.0 | 9.0- 12.0 | - | - | - | Nb 10×Cmin, 1.00max |
| Ferritic-Austenitic Duplex Stainless Steels | | | | | | | | | | | | | |

| Grade | | | Chemical Composition, wt. % ⁽¹⁾⁽⁴⁾ | | | | | | | | | | |
|---------------------|--------------------|--------------|---|------|------|-------|-------|---------------|-------------|-------------------|----|---------------|-------|
| Type | UNS | Cast Grade | C ⁽²⁾ | Si | Mn | P | S | Cr | Ni | Mo ⁽³⁾ | Cu | N | Other |
| 2205 | J92202 (S31803) | CD3MN-4 A | 0.030 | 1.00 | 1.50 | 0.035 | 0.020 | 21.0- 23.0 | 4.5- 6.5 | 2.50- 3.50 | - | 0.15- 0.20 | - |
| 2507 ⁽⁵⁾ | J93404 | CE3MN-5 A | 0.030 | 1.00 | 1.50 | 0.035 | 0.020 | 24.0- 26.0 | 6.0- 8.0 | 2.50- 3.50 | - | 0.10- 0.30 | - |

Notes:

- 1 Maximum, if range or minimum is not indicated.
- 2 Carbon analysis is to be reported to nearest 0.01% except for low-carbon type (0.03% or less), which is to be reported to nearest 0.001%.
- 3 For 316L and 316LN stainless steel castings to be used in cargo tanks of chemical carriers or stagnant/low flow (less than 1 m/second) seawater, the Mo-content is not to be less than 2.5%.
- 4 Chemical compositions determined by ABS as marginally outside of the ranges can be considered, provided the mechanical and corrosion properties are maintained.
- 5 %Cr + 3.3%Mo + 16%N ≥ 41, represents pitting resistance equivalent.

**TABLE 2
 Mechanical Property Requirements of Stainless Steel Castings**

| Grade | | | Tensile Strength, MPa (ksi), Min | Yield Strength, ⁽¹⁾ MPa (ksi), Min $R_{p0.2}$ | Elongation, 50 mm (2 in.) gage, %, Min | Charpy V-Notch | |
|---|--------------------|--------------|----------------------------------|--|--|--------------------------|-------------------------------|
| Type | UNS | Cast Grade | | | | Min. Average, J (ft-lbf) | Test Temp., °C (°F) |
| Austenitic Stainless Steels | | | | | | | |
| 304 | J92600 | CF8 CF8A | 485 (70) | 205 (30) | 35 | 41 (30) | -196 (-320) ⁽²⁾⁽³⁾ |
| 304L | J92500 | CF3 CF3A | 485 (70) | 205 (30) | 35 | | |
| 316 | J92900 | CF8M | 485 (70) | 205 (30) | 30 | | |
| 316L | J92800 | CF3M | 485 (75) | 205 (30) | 30 | | |
| 317 | J93000 | CG8M | 515 (75) | 240 (35) | 25 | | |
| 317L | J92888 | CG3M | 515 (75) | 240 (35) | 25 | | |
| 347 | J92710 | CF8C | 485 (70) | 205 (30) | 30 | | |
| Ferritic-Austenitic Duplex Stainless Steels | | | | | | | |
| 2205 | J92202 (S31803) | CD3MN-4 A | 620 (90) | 415 (60) | 25 | 41 (30) | -20 (-4) ⁽⁴⁾ |
| 2507 | J93404 | CE3MN-5 A | 690 (100) | 515 (75) | 18 | | |

Notes:

- 1 The specified yield strength at both 0.2% and 1.0% are be documented for austenitic stainless steels.
- 2 Charpy tests are required for austenitic stainless steels for materials with design temperatures below -105°C (-157°F). For Liquefied Gases applications, refer to Section 5C-8-6 of the *Marine Vessel Rules*.
- 3 If required by specification or standard, Charpy tests for austenitic stainless steels are to be taken at 5°C (41°F) below design temperature.
- 4 Charpy tests for ferritic-austenitic duplex stainless steels are to be taken at -20°C (-4°F) or 5°C (41°F) below design temperature, whichever is lower.
- 5 For sour service, stainless steel castings used in equipment/components are to comply with the applicable part of NACE MR0175/ISO 15156: Materials for use in H₂S containing environment in oil and gas production.

CHAPTER 2 Requirements for Stainless Steels

SECTION 4 Stainless Steel Pipes

1 Scope

The general requirements defined in Sections 2-3-12 and 2-3-13 of the *ABS Rules for Materials and Welding (Part 2)* are to be applied, unless there are specific requirements for stainless steel pipes in this document.

This Section covers the requirements of seamless and welded austenitic or ferritic-austenitic (duplex) stainless steel pipes.

- i)* Manufacturing process
- ii)* Chemical composition
- iii)* Mechanical properties
- iv)* Corrosion properties
- v)* Nondestructive test

Welded austenitic and duplex stainless steel pipes are to meet additional requirements related to welding.

Reference is also to be made to:

- i)* Section 4-6-1 of the *Marine Vessel Rules*
- ii)* Part 5C, Chapter 9 of the *Marine Vessel Rules*
- iii)* Part 5C, Chapter 8 of the *Marine Vessel Rules*

Note:

Stainless steel pipes may be produced in ferritic, martensitic and precipitation hardened in accordance with applicable recognized industry standards and are to be submitted to ABS for review.

The requirements in this Section cover stainless steel pipes intended to be used for general marine and offshore applications. Alternatively, stainless steel pipes which comply with national or proprietary specifications may be accepted, provided such specifications give reasonable equivalence to these requirements.

2 Reference Documents (1 December 2020)

ASME BPVC IX: Welding, Brazing, and Fusing Qualifications

ASTM A269: Standard Specification for Seamless and Welded Austenitic Stainless Steel Tubing for General Service

ASTM A312: Standard Specification for Seamless, Welded, and Heavily Cold Worked Austenitic Stainless Steel Pipes

ASTM A358: Standard Specification for Electric-Fusion-Welded Austenitic Chromium-Nickel Stainless Steel Pipe for High-Temperature Service and General Applications

ASTM A403: Standard Specification for Wrought Austenitic Stainless Steel Piping Fittings

ASTM A789: Standard Specification for Seamless and Welded Ferritic/Austenitic Stainless Steel Tubing for General Service

ASTM A790: Standard Specification for Seamless and Welded Ferritic/Austenitic Stainless Steel Pipe

ASTM A380: Standard Practice for Cleaning, Descaling, and Passivation of Stainless Steel Parts, Equipment, and Systems

ASTM A813: Standard Specification for Single- or Double-Welded Austenitic Stainless Steel Pipe

ASTM A815: Standard Specification for Wrought Ferritic, Ferritic/Austenitic, and Martensitic Stainless Steel Piping Fittings

ASTM A872: Standard Specification for Centrifugally Cast Ferritic/Austenitic Stainless Steel Pipe for Corrosive Environments

ASTM A928: Standard Specification for Ferritic/Austenitic (Duplex) Stainless Steel Pipe Electric Fusion Welded with Addition of Filler Metal

ASTM A999: Standard Specification for General Requirements for Alloy and Stainless Steel Pipe

ASTM E213: Standard Practice for Ultrasonic Testing of Metal Pipe and Tubing

ASTM E426: Standard Practice for Electromagnetic (Eddy Current) Examination of Seamless and Welded Tubular Products, Titanium, Austenitic Stainless Steel and Similar Alloys

AWS A5.4: Specification for Stainless Steel Electrodes for Shielded Metal Arc Welding

AWS A5.9: Specification for Bare Stainless Steel Welding Electrodes and Rods

AWS A5.22: Specification for Stainless Steel Flux Cored and Metal Cored Welding Electrodes and Rods

AWS A5.30: Specification for Consumable Inserts

3 Approval of Manufacturers

Approval of pipe manufacturers is only required for CNG (refer to 7-1/4 of *ABS Guide for Vessels Intended to Carry Compressed Natural Gases in Bulk*) and if used as structural pipe.

Austenitic and duplex stainless steel pipes are to meet the requirements in Chapter 2, Section 4 during production.

4 Manufacturing Process (1 December 2020)

Austenitic and duplex stainless steel pipes can be seamless or automatically welded, without filler or with filler.

Pipe may be hot or cold finished.

Before delivery, completed components should be descaled, pickled, and passivated in compliance with ASTM A380.

According to ASTM A380, passivation is “the removal of exogenous iron or iron compounds from the surface of a stainless steel by means of a chemical dissolution, most typically by a treatment with an acid solution that will remove the surface contamination, but will not significantly affect the stainless steel itself.”

A sufficient discard is to be made from each ingot to remove injurious defects and segregation.

For welded pipe, welding procedures and welders are to be qualified for applicable products and approved by ABS.

For welded pipe with welding filler, the welding consumable is to be in accordance with AWS 5.4/A5.4M, 5.9/A5.9M, 5.22/A5.22M and A5.30/A5.30M.

5 Chemical Composition

Chemical composition is to be tested in accordance with ASTM A751 or equivalent recognized standard. Heat and product analysis are to be reported. Heat analysis is to be taken from the ladle after refining. Product analysis, if required by the standard, is to be taken from the finished product.

The chemical composition is to comply with 2-4/Table 1 of this document or approved specifications for the applicable stainless steel grade.

6 Heat Treatment

All materials for seamless and welded pipes specified in Chapter 2, Section 4 are to be supplied in the solution treated condition and meet the required mechanical properties.

7 Mechanical Properties

The mechanical properties are to comply with the requirements specified in 2-4/Table 2 for the applicable stainless steel grade.

7.1 Test Specimens and Procedures

Test specimens and procedures are to be in accordance with the applicable requirements of Sections 2-3-12 and 2-3-13 of the *ABS Rules for Materials and Welding (Part 2)*, ASTM A370, E10, E23 or other equivalent industry standards, unless there are specific requirements in this Section.

7.2 Test Frequency

Unless stricter requirements are specified in the applicable standard, the following is to be applied.

One set of mechanical properties are to be tested per heat per lot if number of pipes per lot is not more than 100.

If the number of pipes per lot is more than 100, two set of mechanical properties are to be tested from two pipes per heat per lot.

For pipe with an outside diameter greater than 500 mm (20 in.), one set of mechanical properties is to be tested per heat per lot or every 50 pipes, whichever is more stringent.

Note:

One set of mechanical properties is to include one longitudinal tensile, three longitudinal Charpy V-Notch (LCVN), one flattening test and/or one bend test with mandrel diameter of $3t$ (3 times the pipe wall thickness), and one expansion or flanging test if it is required.

Hardness is to be tested on specimens from two pipes per heat per lot.

7.3 Additional Requirements for Welded Pipe

One tensile test transversely across the weld for pipe with diameter greater than 300 mm (12 in.). Two flattening or two bend tests transverse to the weld with mandrel diameter of $3t$.

7.4 Test Temperature

Tensile tests are to be carried out at room temperature, unless it is required for the tensile properties to be established at a higher or lower temperature.

Charpy V-Notch tests are to be performed at:

- i) -196°C (-320°F) for austenitic stainless steels with the design temperature lower than -105°C (-157°F). For Liquefied Gases application, refer to Section 5C-8-6 of the *Marine Vessel Rules*.
- ii) -20°C (-4°F) or 5°C (41°F) below design temperature for duplex stainless steels, whichever is lower.

7.5 Test Specimen Location

The location of mechanical tests is to be in accordance with the applicable requirements of Sections 2-3-12 and 2-3-13 of the *ABS Rules for Materials and Welding (Part 2)* or recognized standards.

Unless otherwise agreed, the longitudinal tension test may be made in full section of the pipe, up to the capacity of the testing machine. For larger sizes above the capacity of the tension test machine, tension test specimens are to consist of strips cut from the pipe. These specimens are to have a width of 38 mm (1.5 in.) and a gauge length of 50 mm (2 in.).

Charpy test specimen location is to meet the requirements of the standard or any specific design requirements. In general, the Charpy test is to be carried at mid-wall of the pipe. However, depending on the design requirements, other locations as indicated below maybe required.

- i) 1/8 inch below outside diameter (OD) surface
- ii) 1/8 inch above inside diameter (ID) surface

8 Corrosion Properties

Unless otherwise agreed, one corrosion test is to be carried out at the same frequency of the tensile test according to ISO 3651-2, ASTM A262, Practice E, Copper-Copper Sulphate-Sulphuric Acid or the equivalent recognized standard. The bent samples are to be free from the cracks that would indicate the presence of inter-granular attack.

Other corrosion tests such as ASTM G48 for pitting and crevice corrosion, ASTM G78 for crevice corrosion in sea water may be required depending upon the application and heat cycling associated with the heat treatment or repairs.

9 Hydrostatic Test

9.1 General

Except when intended for structural use, such as stanchions, each length of pipe of all grades is to be hydrostatically tested at the mill in accordance with the 2-4/9.2 of this document. When specified by the purchaser, seamless pipe is to be subjected to a nondestructive electrical test in accordance with 2-3-12/31 of the *ABS Rules for Materials and Welding (Part 2)*. When each pipe is hydrostatically tested as a regular procedure during the process of manufacturing, an affidavit covering this test may be accepted by the Surveyor.

9.2 Test Pressure

The test pressures for applicable grades are to be determined by the following equation.

$$P = KSt/D$$

where

$$K = 20 \text{ (200, 2)}$$

$$P = \text{hydrostatic-test pressure, in bar (kgf/cm}^2\text{, psi)}$$

$$t = \text{specified thickness of pipe wall, in mm (in.)}$$

$$D = \text{specified outside diameter of pipe, in mm (in.)}$$

$$S = \text{pipe wall stress}$$

$$= 0.70 \text{ times the specified 0.2 proof yield point, in N/mm}^2 \text{ (kgf/mm}^2 \text{ or psi) for austenitic or duplex steels}$$

$$= 0.80 \text{ times the specified yield point, in N/mm}^2 \text{ (kgf/mm}^2 \text{ or psi) for ferritic and martensitic steels}$$

The hydrostatic test pressure calculated by the equation is to be rounded to the nearest 0.5 MPa (50 psi) for pressure below 7 MPa (1000 psi) and to the nearest 1 MPa (100 psi) for pressure 7 MPa (1000 psi) and above.

The test pressure is to be maintained for a sufficient time to verify tightness, and for at least 5 seconds.

The test pressure is to be measured by means of a suitable, calibrated pressure gauge.

10 Permissible Variation

At a minimum, the finished pipe is to be measured at the same frequency as that required for the tension test. The permissible variation is to be in accordance with ASTM A999 or equivalent standard.

10.1 Permissible Variation in Wall Thickness

The permissible variations in wall thickness for all pipe are based on the ordered thickness and are to conform to that given in the applicable ASTM designation for acceptance, but the minimum thickness for all pipe is not to be less than that required by the Rules/Guide for a specific application regardless of such prior acceptance.

In addition, the following requirements are applicable.

- i)* If the wall thickness of the pipe is specified as a nominal wall thickness, the minimum wall thickness at any point is not to be more than 12.5% under the nominal wall thickness;
- ii)* For forged and bored, the wall thickness is not to vary over the specified by more than 3.2 mm (0.125 in.);

iii) For cast, the wall thickness is not to vary over that specified by more than 1.6 mm (0.0625 in.).

10.2 Permissible Variation in Inside Diameter

For forged, bored and cast, the inside diameter is not to vary under that specified by more than 1.6 mm (0.0625 in.). There is no variation over the specified inside diameter.

10.3 Permissible Variation in Outside Diameter

The outside diameter is not to vary more than plus 1% from the nominal diameter specified and is not to vary more than minus 0.8 mm (0.031 in.) from the nominal diameter specified.

11 Inspection

2-3-12/31 and 2-3-12/35 of the *ABS Rules for Materials and Welding (Part 2)* are applicable for pipe inspection.

The pipes are to be reasonably straight, free from defects, and have a workmanlike finish. At a minimum, the finished pipe is to be visually inspected at the same frequency as that required for the tension test for the applicable grade. Welding repair to the pipe is not to be carried out without the purchaser's approval and is to be to the Surveyor's satisfaction.

For seamless pipe, refer to 2-3-12/31 of the *ABS Rules for Materials and Welding (Part 2)*.

Unless otherwise agreed or required, for welded pipes, an automatic nondestructive test of the whole length of the weld is required. Such pipes are considered equivalent to seamless pipes for design purpose.

At the discretion of ABS, Ultrasonic testing per ASTM E213 or Eddy-Current testing per E426 may be accepted for pipe nondestructive testing.

12 Marking, Retest and Rejection

Identification markings are to be legibly stenciled, stamped, or rolled on each pipe, except that in the case of small-diameter pipe which is bundled, the required markings are to be placed on a tag securely attached to the bundle. The markings are to include the following:

- Name or brand of the manufacturer
- ABS Grade or ASTM Designation and Type or Grade (304, 304L, 2205, etc.)
- Heat number or manufacturer's number by which the heat can be identified
- Test pressure or the letters NDE
- Method of forming (i.e., butt-welded, lap-welded, electric-resistance-welded or seamless hot-finished or cold-drawn)
- ABS markings by the Surveyor

13 Material Test Report (MTR)

The manufacturer is to provide the required type of material test report giving the following, at a minimum:

- i) Purchaser's name and order number
- ii) Specifications or grades
- iii) Manufacturing process
- iv) Dimensions or thickness
- v) Weight

- vi) Heat Number
- vii) Lot Number
- viii) Chemical composition by head analysis
- ix) Chemical composition by product analysis, if required
- x) Mechanical properties
- xi) Width in the gage length, if longitudinal strip tension test specimens were used
- xii) Bend test result
- xiii) Flattening test result
- xiv) Hydrostatic test pressure if applicable
- xv) Corrosion testing if required
- xvi) Nondestructive test if required
- xvii) Identification number of piece, including test specimen number where appropriate

TABLE 1
Chemical Composition of Stainless Steel Pipes

| Grade | | Chemical Composition, wt. % ⁽¹⁾⁽⁴⁾ | | | | | | | | | | |
|---|--------|---|------|------|-------|-------|-----------|-----------|-------------------|------|-----------|------------------------------|
| Type | UNS | C ⁽²⁾ | Si | Mn | P | S | Cr | Ni | Mo ⁽³⁾ | Cu | N | Other |
| Austenitic Stainless Steels | | | | | | | | | | | | |
| 304 | S30400 | 0.080 | 1.00 | 2.00 | 0.045 | 0.030 | 18.0-20.0 | 8.0-11.0 | - | - | 0.010 | - |
| 304L | S30400 | 0.030 | 1.00 | 2.00 | 0.045 | 0.030 | 18.0-20.0 | 8.0-12.0 | - | - | 0.10 | - |
| 316 | S31600 | 0.080 | 1.00 | 2.00 | 0.045 | 0.030 | 16.0-18.0 | 10.0-14.0 | 2.00-3.00 | - | 0.10 | - |
| 316L | S31603 | 0.030 | 1.00 | 2.00 | 0.045 | 0.030 | 16.0-18.0 | 10.0-14.0 | 2.00-3.00 | - | 0.10 | - |
| 317 | S31700 | 0.080 | 1.00 | 2.00 | 0.045 | 0.030 | 18.0-20.0 | 11.0-15.0 | 3.00-4.00 | - | 0.10 | - |
| 317L | S31703 | 0.030 | 1.00 | 2.00 | 0.045 | 0.030 | 18.0-20.0 | 11.0-15.0 | 3.00-4.00 | - | 0.10 | - |
| 321 | S32100 | 0.080 | 1.00 | 2.00 | 0.045 | 0.030 | 17.0-19.0 | 9.0-12.0 | - | - | 0.10 | Ti5×(C+N) min, 0.70max |
| 347 | S34700 | 0.080 | 1.00 | 2.00 | 0.045 | 0.030 | 17.0-19.0 | 9.0-12.0 | - | - | - | Nb10×Cmin, 1.00max |
| Ferritic-Austenitic Duplex Stainless Steels | | | | | | | | | | | | |
| - | S31803 | 0.030 | 1.00 | 2.00 | 0.030 | 0.020 | 21.0-23.0 | 4.5-6.5 | 2.5-3.5 | - | 0.08-0.20 | - |
| 2205 | S32205 | 0.030 | 1.00 | 2.00 | 0.030 | 0.020 | 22.0-23.0 | 4.5-6.5 | 3.0-3.5 | - | 0.14-0.20 | - |
| 2507 ⁽⁵⁾ | S32750 | 0.030 | 0.80 | 1.20 | 0.035 | 0.020 | 24.0-26.0 | 6.0-8.0 | 3.0-5.0 | 0.50 | 0.24-0.32 | - |

Notes:

- 1 Maximum, if range or minimum is not indicated.
- 2 Carbon analysis is to be reported to nearest 0.01% except for low-carbon type (0,03% or less), which is to be reported to nearest 0.001%.
- 3 For 316L and 316LN stainless steel pipes to be used in cargo tanks of chemical carriers or stagnant/low flow (less than 1 m/second) sea water, the Mo-content is not to be less than 2.5%.
- 4 Chemical compositions determined by ABS to be marginally outside of the ranges can be considered, provided the mechanical and corrosion properties are maintained.
- 5 %Cr + 3.3%Mo + 16%N ≥ 41, represents pitting resistance equivalent.

TABLE 2
Mechanical Properties Requirements of Stainless Steel Pipes

| Type | UNS | Tensile Strength, MPa (ksi), Min | Yield Strength, ⁽¹⁾ MPa (ksi), Min | | Elongation, 50 mm (2 in.) gage, %, Min | Hardness, ⁽⁵⁾⁽⁶⁾ HBW (HRB/HRC), Max | Charpy V-Notch | |
|---|--------|----------------------------------|---|-------------------|--|--|---------------------------------|--|
| | | | R _{p0.2} | R _{p1.0} | | | Min. Average, J (ft-lbf) | Test Temp., °C (°F) |
| Austenitic Stainless Steels | | | | | | | | |
| 304 | S30400 | 515 (75) | 205 (30) | 245 (36) | 30 | 201 HBW (92) HRB | 27 (20) Trans. 41 (30) Long. | -196 (-320) ⁽²⁾ ⁽³⁾ |
| 304L | S30403 | 485 (70) | 170 (25) | 210 (31) | 30 | 201 HBW (92) HRB | | |
| 316 | S31600 | 515 (75) | 205 (30) | 245 (36) | 30 | 217 HBW (95) HRB | | |
| 316L | S31603 | 485 (70) | 170 (25) | 210 (31) | 30 | 217 HBW (95) HRB | | |
| 317 | S31700 | 515 (75) | 205 (30) | 245 (36) | 30 | 217 HBW (95) HRB | | |
| 317L | S31703 | 515 (75) | 205 (30) | 245 (36) | 30 | 217 HBW (95) HRB | | |
| 321 | S32100 | 515 (75) | 205 (30) | 245 (36) | 30 | 217 HBW (95) HRB | | |
| 347 | S34700 | 515 (75) | 205 (30) | 245 (36) | 30 | 201 HBW (95) HRB | | |
| Ferritic-Austenitic Duplex Stainless Steels | | | | | | | | |
| - | S31803 | 620 (90) | 450 (65) | - | 25 | 290 HBW (30) HRC | 27 (20) Trans. 41 (30) Long. | -20 (-4) ⁽⁴⁾ |
| 2205 | S32205 | 655 (95) | 450 (65) | - | 25 | 290 HBW (30) HRC | | |
| 2507 | S32750 | 800 (116) | 550 (80) | - | 15 | 300 HBW (32) HRC | | |

Notes:

- 1 The specified yield strength at both 0.2% and 1.0% are be documented for austenitic stainless steels.
- 2 Charpy tests are required for austenitic stainless steels for materials with design temperatures below -105°C (-157°F). For Liquefied Gases applications, refer to Section 5C-8-6 of the *Marine Vessel Rules*.
- 3 If required by specification or standard, Charpy tests for austenitic stainless steels are to be taken at 5°C (41°F) below design temperature.
- 4 Charpy tests for ferritic-austenitic duplex stainless steels are to be taken at -20°C (-4°F) or 5°C (41°F) below design temperature, whichever is lower.
- 5 Hardness is required for austenitic and ferritic-austenitic stainless steel pipes.
- 6 For sour service, stainless steel pipes used in equipment/components are to comply with the applicable part of NACE MR0175/ISO 15156: Materials for use in H₂S containing environment in oil and gas production.

CHAPTER 2 Requirements for Stainless Steels

SECTION 5 Stainless Steel Clad Plates

1 Scope

The general requirements for base metal is referred to Sections 2-1-2 or 2-3-2 of the *ABS Rules for Materials and Welding (Part 2)* or an equivalent standard.

This Section covers plate of a base/backing steel to which is integrally and continuously bonded on one or both sides a layer by metallurgical bonding.

The plate of a carbon steel or low-alloy base metal with the stainless steels as the clad materials is to be specified in Chapter 2, Section 5 of this document.

Note: Plate with the Ni-based alloy as clad materials is to be submitted to ABS for review.

The requirements in this Section cover stainless steel clad plates intended to be used for pressure vessel, chemical tanks, etc. Alternatively, stainless steel clad plates which comply with national or proprietary specifications may be accepted, provided such specifications give reasonable equivalence to these requirements.

2 Reference Documents

ASME BPVC IX: Welding, Brazing, and Fusing Qualifications

ASTM A20: Specification for General Requirements for Steel Plates for Pressure Vessel

ASTM A240: Specification for Chromium and Chromium Nickel Stainless Steel Plate, Sheet, and Strip for Pressure Vessels and for General Applications

ASTM A263: Standard Specification for Stainless Chromium Steel-Clad Plate

ASTM A264: Specification for Stainless Chromium-Nickel Steel-Clad Plate

ASTM A480: Specification for General Requirements for Flat-Rolled Stainless and Heat-Resisting Steel Plate, Sheet, and Strip

ASTM A578: Standard Specification for Straight-Beam Ultrasonic Examination of Rolled Steel Plates for Special Applications

3 Approval of Manufacturers

Stainless steel clad plates are to be manufactured at facilities which have been approved by ABS.

Where it is intended to weld clad plate during fabrication, welding is to be done according to approved welding procedures by qualified welders and welding operators. Procedures and welders/operators are to be qualified in accordance with AWS, ASME Section IX or equivalent.

In addition, if clad plates are to be hot cut, it is to be demonstrated that hot cutting does not result in delamination.

The clad plate with stainless steel cladding layer is to meet the requirements in Chapter 2, Section 5 of this document during manufacturing approval. A production test procedure is to be submitted to ABS for review and approval.

4 Manufacturing Process

4.1 Base Metal

The steel is to be made by one or more of the following processes: open-hearth, basic-oxygen or electric-furnace. The steel may be cast in ingots or may be strand (continuous) cast. The ratio of reduction of thickness from strand (continuous) cast slab to finished plate is to be a minimum of 3 to 1 unless otherwise agreed and approved.

For coiled plate, the manufacturer or processor is to submit supporting data for review and approval to indicate that the manufacturing, processing and testing will provide material to comply with the Rules/Standards.

4.2 Clad Metal

The alloy-cladding metal is to be metallurgically bonded to the base metal. The bonding strength is to meet the requirements in this document.

4.3 Bonded Products

The bonded product may be produced by rolling. The base metal and clad metal is temporarily fixed by welding, then heated up in furnace and rolled to form a metallurgical bonded cladding plate.

For explosively bonded products, the alloy-cladding metal may be comprised of two or more separate alloy plates or sheets completely metallurgical bonded together to form a single fabricated plate. Reference can be made to Appendix 2-5-A4 of the ABS *Rules for Materials and Welding (Part 2)*. However, this section should be referenced for Aluminum to Steel explosively bonded joints.

The process of manufacture is to be specially approved by either rolled cladding or by explosive cladding.

5 Chemical Composition

The chemical composition is to be reported for plates with the same overall thickness, cladding thickness and backing steel, or per 20 tons, whichever is more stringent.

5.1 Base Metal

The base metal is to be carbon or low-alloy steel appropriate for the application either for hull tank construction or pressure vessel construction, and comply with the applicable standard and chemical composition.

5.2 Clad Metal

The alloy-cladding metal is to comply with the designation and chemical composition in 2-1/Table 1 of this document, ASTM A240 or equivalent.

6 Heat Treatment

6.1 Base Metal

All plates are to be furnished in the normalized, tempered, normalized and tempered, or quenched and tempered condition permitted by the backing steel. Stress relieving is permitted, provided the temperature is 40°C (75°F) or more below the minimum tempering temperature.

6.2 Clad Metal

Prior to bonding, the clad metal is supplied in the solution treated condition.

7 Mechanical Properties

The mechanical properties are to comply with the requirements specified in 2-5/7 of this document. In addition, the mechanical properties requirements for base metal are to be referred to ASTM A20, or equivalent.

7.1 Tensile Test

The tensile test for clad plate is to be performed on transverse direction. The gauge (extensometer) is to be applied to the base metal.

For steel intended for hull structure, one set of tensile test is to be taken per lot or per five plates, whichever is more stringent.

For steel intended for pressure vessels (PV) designed in accordance with a recognized code such as ASME-BPVC, PD5500, EN13445 or other accepted PV codes, one set of tensile testing is to be taken for each plate.

7.1.1 Tensile Test Details

- i) A lot is to be composed of plates having the same overall thickness, cladding thickness and cast of backing steel, and mass not exceeding 20 tons.
- ii) A set of tensile test includes the following:
 - One test of the base metal after removal of the cladding layer. Test results are to meet the requirements for the base metal.
 - One test from the full scale clad plate. The minimum tensile strength can be calculated by:

$$R_m = (T_1 R_{m1} + T_2 R_{m2}) / T \quad \text{MPa (ksi)}$$

where

R_{m1} = minimum tensile strength of base metal, MPa (ksi)

R_{m2} = minimum tensile strength of the cladding metal, MPa (ksi)

T = nominal thickness of the clad plate, which is $T_1 + T_2$, mm (in.)

T_1 = nominal thickness of the base metal, mm (in.)

T_2 = nominal thickness of the cladding metal, mm (in.)

The requirement of minimum elongation specified for base metal is applicable to the full scale clad plate.

7.2 Charpy Test

If required, longitudinal Charpy V-Notch tests are to be taken on the base metal at the specified test temperature and meet the specified energy values.

7.3 Shear Test

The shear test is carried out in accordance with ASTM A264. The minimum shear strength is 140 MPa (20 ksi).

The minimum cladding thickness for shear test is to be 1.9 mm (0.075 in.). Testing for shear strength for cladding thickness less than 1.9 mm (0.075 in.) is to be submitted to ABS for review.

7.4 Bend Test Bonding Strength

Typically, the mandrel diameter is 3 times of the plate thickness. One set (2 bend tests) of bending samples is to be bent through an angle of 180° for each bonded mother plate. Unless otherwise agreed, the maximum separation is to be less than 25% on both edges of the bent portion. After bend test, test samples are not to show cracking or de-bonding between the clad layer and base metal.

7.4.1 Bend Test Bonding Strength Details

- i)* Single side clad plate, one set of bend samples includes one sample bent with the cladding layer in tension and one sample with the cladding layer in compression.
- ii)* Double sides clad plate: one set of bend samples is to include both cladding layers are tested both ways (in tension and in compression).
- iii)* At the discretion of ABS, the bend test bonding strength may be an alternative to, or in addition to, the shear strength test.

8 Corrosion Properties

Unless otherwise agreed or required, one corrosion test for the cladding layer is to be carried out to the same frequency of the tensile test according to ISO 3651-2, ASTM A262, Practice E, Copper-Copper Sulphate-Sulphuric Acid or an equivalent recognized standard. The bent samples are to be free from the cracks that would indicate the presence of inter-granular attack.

Other corrosion tests such as ASTM G48 for pitting and crevice corrosion, ASTM G78 for crevice corrosion in sea water may be required depending upon the application and heat cycling associated with the heat treatment or repairs.

9 Inspection

The material is to be free of injurious defects, shall have a workmanlike appearance and conform to the designated finish.

Plate alloy surfaces are to be blasted (descaled by sand or stainless grit, shot or wire, or equivalent), pickled, blast-cleaned and pickled, or 100 % conditioned.

Clad plates with less than 10 mm (0.375 in.) total thickness are to be visually inspected for bonding integrity.

In addition, clad plates with 10 mm (0.375 in.) total thickness and above are to be ultrasonic inspected in accordance with ASTM A578 and plates are to be supplied with 100% coverage.

Visual inspection and ultrasonic inspection can be used to complement each other for any suspect unbonded areas.

Before inspection, the required quality level (class) is to be agreed and documented in the purchase order. After inspection, the quality levels are to be marked as follows:

- i) Class 1 – No single un-bonded area exceeding 25 mm (1 in.) in its longest dimension with total un-bonded area not to exceed 1% of the total clad surface area;
- ii) Class 3 – No single un-bonded area exceeding 75 mm (3 in.) in its longest dimension with total un-bonded area not to exceed 3% of the total clad surface area;
- iii) Class 5 – No single un-bonded area exceeding 58 cm² (29 in²) with total un-bonded area not to exceed 5% of the total clad surface area;

When no quality level is specified, plates are to be furnished as Class 5, at least.

10 Defects and Repair

At discretion of ABS, surface defects in cladding layer may be repaired. Unless otherwise agreed, the following requirements are to be applied:

- i) The defective area is to be removed and the area is to be examined by liquid penetrant or magnetic particle to confirm all defective area has been removed;
- ii) The weld repair is to be deposited with a qualified procedure and qualified welder. The consumables are to be suitable for welding the cladding material. The surface finish of the repaired area is to be restored to the condition of the rest of the cladding;
- iii) The repaired area is to be examined by a liquid penetrant method;
- iv) The repair location, the extent of the weld repair, the repair procedure and nondestructive test result shall be documented as a part of the Material Test Report (MTR).

11 Marking

The finished products are to be clearly marked including the base metal grade and the clad metal grade. The grade or designation for base metal are to be referred to Section 2-3-2 of the *ABS Rules for Materials and Welding (Part 2)* and ASTM A20.

For example:

- ABS PV grade: AB Clad/316L/MA, AB Clad/316L/N etc.
- Non-ABS PV grade: AB Clad/316L/A662-A etc.

12 Material Test Report (MTR)

1-1/5 is generally applicable. In addition, the following is to be included for clad plate:

- i) Chemical analysis of the base metal and the cladding metal
- ii) Test result required in 2-5/7
- iii) Clad quality level such as class 1, 3 or 5 and the nondestructive test if required referred to 2-5/9
- iv) Any applicable construction code and appropriate documentation for the bonded clad product by rolling or explosion

CHAPTER 2 Requirements for Stainless Steels

APPENDIX 1

Procedure for the Approval of Manufacturers of Rolled Stainless Steels

1 Scope

1.1 General

In accordance with 1-1/2.2 and 2-1/3, this Appendix provides specific requirements for the approval of manufacturers of rolled austenitic and ferritic-austenitic (duplex) stainless steel products.

The manufacturer approval procedure is intended to verify the manufacturer's capability of furnishing satisfactory products in a consistent manner under effective process and production controls in operation.

This Appendix only addresses the approval of manufacturers for rolled austenitic and duplex stainless steel products. If stainless steels are supplied in semi-finished product condition, slabs, blooms, billet, etc., the requirements of Appendix 2-A4-1 of the *ABS Rules for Materials and Welding (Part 2)* applicable to stainless steels are to be followed, together with any other requirements specific to the production of semi-finished stainless steels.

1.2 Range of Approval

This Appendix is applicable to the approval of manufacturers for rolled stainless steel products such as plates, sections and bars.

Range of approval is to be limited to the following:

- Stainless steel grade
- Product form, such as plates, sections, bars, etc.
- Manufacturing process
- Maximum thickness or outside diameter

Each product form is to be qualified individually.

i) For rolled austenitic stainless steel products:

- It is common industry practice to dual certify 300 series austenitic stainless steels as standard grade and low carbon grade. Qualification of a higher carbon grade by a lower carbon grade such as 304 by 304L, 316 by 316L and 317 by 317L may be permitted, provided that both grades meet the carbon requirement of the L grade and mechanical properties of non-L grade under the same processing parameters.

- Qualification of a lower alloy grade by a higher alloy grade such as 304 by 316, or 304 and 316 by 317, or 304L by 316L, or 304L and 316L by 317L, may be permitted, provided that the chemistry and mechanical properties meet the requirements of all grades under the same processing parameters.
 - For nitrogen-stabilized austenitic stainless steels, qualification of a lower alloy grade by a higher alloy grade such as 316LN by 317LN, may be permitted, provided that the chemistry and mechanical properties meet the requirements of all grades under the same processing parameters.
 - For grade 321 and 347, the approval is to be qualified independently.
- ii)* For duplex stainless steels, the approval is to be qualified independently for each grade or designation.

2 Reference Documents

Manufacturer is to provide list of the applicable standards and specifications relevant to the steel production.

3 Approval Application

3.1 Documents to be Submitted

3.1.1 Initial Approval (1 December 2020)

The manufacturer is to submit to ABS request of approval together with proposed approval test program (see 2-A1/4.1) and general information relative to:

- i)* Name and address of the manufacturer, location of the workshops, general indications relevant to the background, dimension of the works, estimated total annual production of finished products for shipbuilding and for other applications, as deemed useful.
- ii)* Organization and quality:
- Organizational chart
 - Staff employed
 - Organization of the quality control department and its staff employed
 - Qualification of the personnel involved in activities related to the quality of the products
 - Certification of compliance of the quality system with ISO 9001 or 9002, if any
 - Approval certificates already granted by other Classification Societies or other recognized organizations, such as API (American Petroleum Institute)
- iii)* Manufacturing facilities:
- Flow chart of the manufacturing process
 - Origin and storage of raw materials
 - Storage of finished products
 - Equipment for systematic control during fabrication
- iv)* Details of inspections and quality control facilities:
- Details of system used for identification of materials at the different stages of manufacturing
 - Equipment for mechanical tests, chemical analyses and metallography and relevant calibration procedures

- Equipment for nondestructive examinations
- List of quality control procedures
- v) Type of products (plates, sections, coils), grades of steel, range of thickness and target material properties as follows:
 - Range of chemical composition and aim analyses, including grain refining, micro alloying and residual elements, for the various grades of stainless steels. If the range of chemical composition depends upon thickness and supply condition, the different ranges are to be specified, as appropriate
 - Target pitting resistance number (PRN) calculated to the formula $\%Cr + 3.3\%Mo + 16\%N$
 - Production statistics of the chemical composition and mechanical properties (0.2% and proof 1.0% yield strength, UTS, Elongation, Reduction of Area and CVN). The statistics are intended to demonstrate the capability to manufacture the steel products in accordance with the requirements
- vi) Steelmaking:
 - Steel making process and capacity of furnace/s or converter/s
 - Raw material used
 - Deoxidation, decarburization and alloying practice
 - Desulfurization, dephosphorization and vacuum degassing installations;
 - Casting methods: ingot or continuous casting. In the case of continuous casting, information relevant to type of casting machine, teeming practice, methods to prevent re-oxidation, inclusions and segregation control, stirring, soft reduction, etc., is to be provided, as appropriate
 - Ingot or slab size and weight
 - Ingot or slab treatment: scarfing and discarding procedures (nose and tail)
- vii) Reheating and rolling:
 - Rolling: reduction ratio of slab/bloom/billet to finished product thickness, rolling and finishing temperatures
 - Descaling treatment during rolling
 - Capacity of the rolling stands
 - Type of furnace and treatment parameters
- viii) Heat treatment:
 - Type of furnaces, heat treatment parameters and their relevant records
 - Accuracy and calibration of temperature control devices
 - Pickling or other surface finish processing after heat treatment, refer to ASTM A380
- ix) Recommendations for working and welding:
 - Working
 - Handling and storage
 - Cleaning, pickling and passivating recommendations for application, fabrication and in-service
 - Cutting and machining
 - Protection of plate surface during construction

- Cold and hot working recommendations in addition to the normal practice used in the shipyards and workshops
- Welding
 - Welding process
 - Welding parameters such as consumable material grade, maximum interpass temperatures, etc.
 - Preparation of edges for welding such as weld bevel angle, grinding, cleaning
 - Recommendations for minimum and maximum heat input for the grade. Note: heat input is to be minimized
 - Tack welding recommendations
 - Distortion control during welding
 - Treatment after welding-grinding, cleaning, and pickling.
- x)* Where any part of the manufacturing process is assigned to other companies or other manufacturing plants, additional information required by ABS is to be included.
- xi)* Approval already granted by other IACS Member Societies and documentation of approval tests performed.

3.1.2 Changes to the Approval Conditions

Where any one or more of the following cases 2-A1/3.1.2(a) through 2-A1/3.1.2(e) are applicable, the manufacturer is to submit to ABS the documents required in 2-A1/3.1.1 together with the request of changing the approval conditions.

- i)* Changes to of the manufacturing process (steel making, casting, rolling and heat treatment)
- ii)* Changes to the maximum thickness (dimension)
- iii)* Changes to the chemical composition, added element, etc.
- iv)* Subcontracting the rolling, heat treatment, etc.
- v)* Use of the slabs, blooms and billets manufactured by companies other than the ones verified in the approval test

However, where the documents are duplicated by the ones at a previous approval for the same type of product, some or all of the documents may be omitted, except the approval test program (see 2-A1/4.1).

4 Approval Tests

4.1 Extent of the Approval Tests

The extent of the test program is specified in 2-A1/4.6 and 2-A1/4.7. The test program may be modified on the basis of the preliminary information submitted by the manufacturer.

In particular, a reduction of the indicated number of casts, steel plate thicknesses and grades to be tested or complete omission of the approval tests may be considered, taking into account:

- i)* Approval already granted by other Classification Societies and documentation of approval tests performed, in such cases, documentation is to be verified by the ABS surveyor
- ii)* Grades of steel to be approved and availability of long term historical statistic results of chemical and mechanical properties
- iii)* Change of the approval conditions

Approval of a higher grade steel may cover approval of a lower grade, provided that the chemistry and mechanical properties meet the requirements of all grades under the same processing parameters. Refer to 2-A1/1.2 for range of approval. For ABS to consider the qualification of a grade by another grade, the stainless steel mill will be required to submit additional metrics such as yearly production quantity of the grades, together with the product forms and thickness in question.

On the other hand, an increase of the number of casts and thicknesses to be tested may be required in the case of newly developed types of stainless steels or manufacturing processes, or applications where more stringent requirements are specified.

In case of multi-source slabs or a change of slab manufacturer, the rolled steel manufacturer is required to obtain the approval of the manufacturing process of rolled steels using the slabs from each slab manufacturer and to conduct approval tests in accordance with 2-A1/4.6 and 2-A1/4.7. A reduction or complete omission of the approval tests may be considered, taking into account previous approval, at the discretion of ABS.

4.2 Approval Test Program

Where the number of tests differs from those shown in 2-A1/4.6 and 2-A1/4.7, the program is to be agreed by ABS before the commencement of the tests.

4.3 Approval Survey

The approval tests are to be witnessed by the Surveyor at the manufacturer's plant. An inspection by the Surveyor of the plant in operation will be required.

If testing facilities are not available at the works, the tests are to be carried out at recognized laboratories.

4.4 Selection of the Test Product

For each grade of steel and for each manufacturing process (e.g., steel making, casting, rolling and condition of supply), one test product with the maximum thickness (dimension) to be approved is, in general, to be selected for each kind of product.

In addition, for initial approval, ABS will require selection of one test product of average thickness.

The selection of the casts for the test product is to be based on the typical chemical composition under typical manufacturing conditions for the product types, grades, and dimensions for the approval that is requested.

4.5 Position of the Test Samples

Unless otherwise agreed, the test samples are to be taken from the product (plate, flat, section, bar) corresponding to the top of the ingot, or, in the case of continuous casting, from the last rolled product and a random product.

The test samples are to be taken from the following positions:

- i) *Plates and Flats with a Width ≥ 600 mm.* The test samples are to be taken from one end at a position approximately midway between the axis in the direction of rolling and the edge of the rolled product (see 2-A1/Figure 1). Unless otherwise agreed the tension test specimens are to be prepared with their longitudinal axes transverse to the final direction of rolling;
- ii) *Flats with a Width < 600 mm, Bulb Flats and Other Sections.* The test samples are to be taken from one end at a position approximately one-third from the outer edge (see 2-A1/Figures 2, 3, 4) or in the case of small sections, as near as possible to this position. In the case of channels, beams or bulb angles, the test samples may alternatively be taken from a position approximately one quarter of the width from the web centerline or axis (see 2-A1/Figures 5, 6]. The tension test

specimens may be prepared with their longitudinal axes either parallel or transverse to the final direction of rolling;

- iii) *Bars and Other Similar Products.* The test samples are to be taken so that the longitudinal axes of the test specimens are parallel to the direction of rolling (see 2-A1/Figure 7).

FIGURE 1
Position of the Test Samples – Plates and Flats

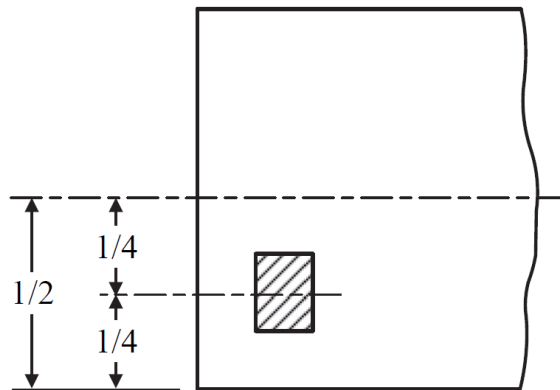

FIGURE 2
Position of the Test Samples – Bulb Flats

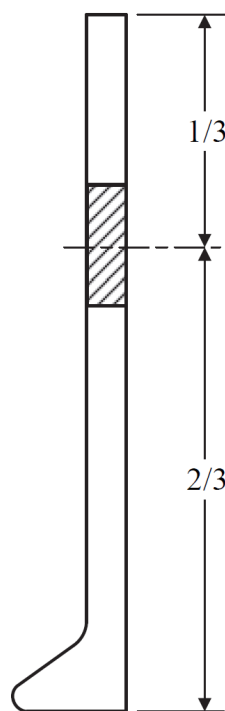

FIGURE 3
Position of the Test Samples – Angles

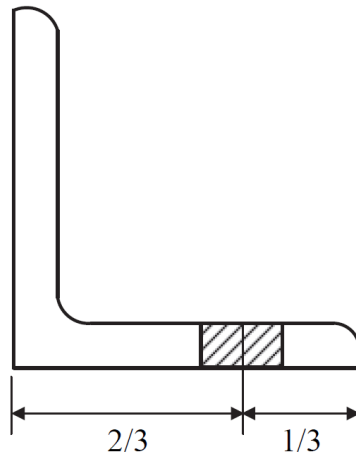

FIGURE 4
Position of the Test Samples – Unequal Angles

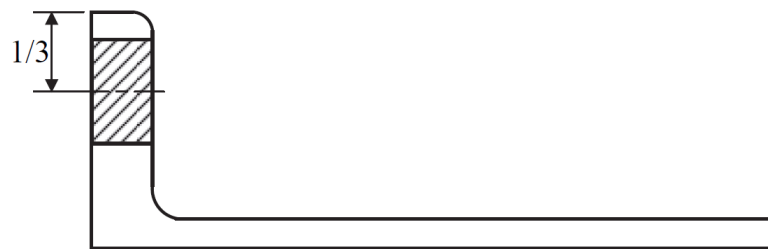

FIGURE 5
Position of the Test Samples – Channels and Beams

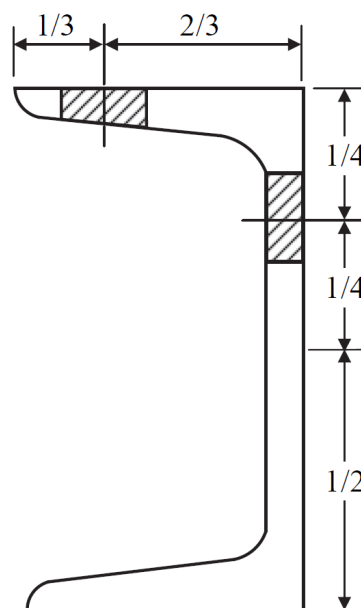

FIGURE 6
Position of the Test Samples – Sections (Joists)

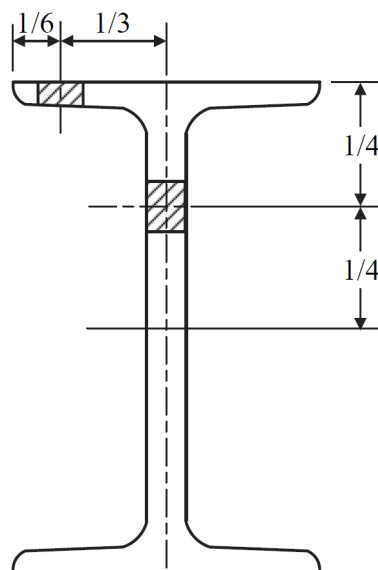
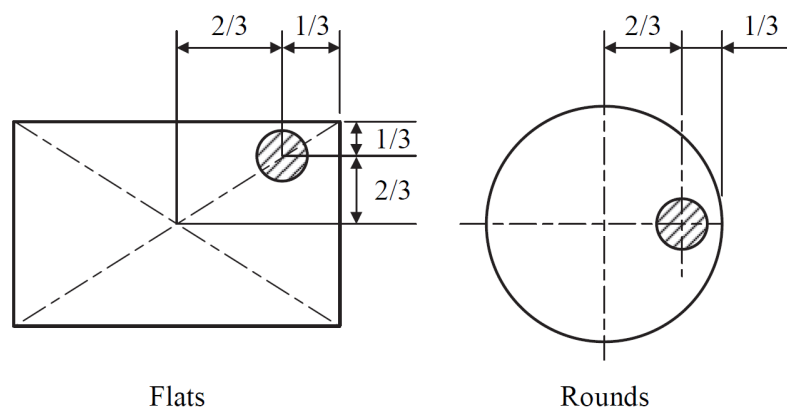

FIGURE 7
Position of the Test Samples – Flats and Rounds (Bars)



Flats and rounds (bars)

4.6 Tests on Base Material

Unless otherwise agreed or required, at least two heats are to be performed for each qualification test. Test samples are to be taken in the final delivery condition.

4.6.1 Type of Tests

The tests as indicated in 2-A1/Table 1 are to be carried out.

4.6.2 Test Specimens and Testing Procedure

The test specimens and testing procedures are to be in accordance with Sections 2-1-1 and 2-3-1 of the *ABS Rules for Materials and Welding (Part 2)*, and Chapter 1, Section 1 of this document with particular attention to the following:

4.6.2(a) Tensile Test

- i) Tensile is required for all grades and stress-strain curves are to be included in qualification report
- ii) 0.2% and 1.0% yield are to be reported for austenitic stainless steels
- iii) For plates made from hot rolled strip, one additional tensile specimen is to be taken from the middle of the strip constituting the coil
- iv) For plates having thickness higher than 40 mm (1.6 in.), when the capacity of the available testing machine is insufficient to allow the use of test specimens of full thickness, multiple flat specimens, representing collectively the full thickness, can be used. Alternatively, two round specimens with the axis located at one quarter and at mid-thickness can be taken
- v) For rolled bar having diameter higher than 100 mm (4 in.), tensile specimens are to be taken with the axis located at one third of the radius and at the center of the bar

Yield, tensile strength and elongation are to be reported and meet requirements in 2-1/Table 2 or equivalent standard (e.g., ASTM A240, or an alternative standard) if approval is requested for a non-ABS listed grade such as ferritic, martensitic or precipitated grades. The reduction of area is to be reported for information.

4.6.2(b) *Impact Test*

- i) For plates made from hot rolled coil strip, one additional set of impact specimens is to be taken from the middle of the strip constituting the coil.
- ii) For long products, one set of impact specimens is to be taken from both ends of the test product.
- iii) For plates having thickness higher than 40 mm (1.6 in.), one additional set of impact specimens is to be taken with the axis located at mid-thickness.
- iv) For rolled bar having diameter higher than 100 mm (4 in.), impact specimens are to be taken with the axis located at one third of the radius and at the center of the bar.
- v) Heat number, test piece location and orientation, test temperature and absorbed energy for average and single, fracture appearance, the lateral expansion and the percentage crystallinity are to be reported.
- vi) For duplex stainless steels, the results are to be plotted in the form of transition curves. This also applies to ferritic, martensitic and precipitated stainless steels, if approval is requested.
- vii) Charpy impact energy is to be reported and meet requirements in 2-1/Table 2.

4.6.2(c) *Chemical Analyses*

Both the ladle and product analyses are to be reported. The material for the product analyses should be taken from the top tensile test specimen. Elements specified in 2-1/Table 1 or a recognized standard are to be reported. The report is to contain both the specified limits and the actual measured contents. Any intentionally added elements and any residual elements are also to be reported.

4.6.2(d) *Corrosion Test*

Corrosion test is to be performed for all stainless steel grades. Test specimens are to include mid thickness of the plate. Surface finish of test specimens are to be representative of the surface of the products.

- i) *Inter-granular Corrosion Test:* Test samples are to be subjected to inter-crystalline corrosion tests in accordance with ASTM A262, E–Copper-copper sulfate-sulfuric acid test for detecting susceptibility to inter-granular attack in austenitic stainless steels, or another recognized standard. The bend specimens before and after test are to be

photographed and reported. The bend specimens are to be free from cracks due to the inter-granular corrosion;

ii) *Pitting Corrosion Test:* Test samples are to be subjected to pitting corrosion testing in accordance with ASTM G48, A, or another recognized standard. The exposure and test temperature are to be in accordance with ASTM G48. For duplex, the following is applicable:

- 2205 duplex + 20°C (68°F), 24 hours
- 2507 duplex + 50°C (122°F), 24 hours

No pitting on surfaces is permitted at 20x magnification, and the general mass loss is to be less than 4.0 g/m².

4.6.2(e) *Micrographic Examination*

Metallographic examination is required for all stainless steel grades in longitudinal and transverse directions from both ends of products.

The micrographs are to be representative of the full thickness. In general, at least three examinations are to be made at surface, one quarter and mid-thickness of the product for thick products.

Photomicrographs are to be taken at '100 magnification and additionally at '500 magnification, together with a brief microstructural description.

For all stainless steel grades, micrographs are to be free from detrimental inter-metallic phases and grain boundary precipitates.

For duplex stainless steels, the ferrite percentage is to be determined in accordance with ASTM E562 or equivalent standard. The ferrite percentage is to be within 30% to 70%.

The etching methods for metallographic examination are to be reported.

4.6.2(f) *Through Thickness Tensile Test, if required*

The test is to be performed in accordance with 2-1-1/9. The test results are to be in accordance with the specified requirements.

TABLE 1
Tests for Rolled Austenitic Stainless Steel Products Manufacturer Approval

| <i>Type of Test</i> | <i>Position of the Samples and Direction of the Test Specimen ⁽¹⁾</i> | <i>Remarks</i> |
|-------------------------|---|---|
| Chemical analysis (%) | - | Complete analysis from ladle and products including micro alloying and residual elements |
| Microstructure | Both ends of product from top of first ingot Both ends of product from tail end of con-cast string Test – longitudinal and transverse | ×100 and ×500 magnification at surface, one quarter and mid-thickness Determine ferrite delta content and detrimental phases (sigma) |
| Hardness ⁽⁵⁾ | Both ends of product from top of first ingot Both ends of product from tail end of con-cast string | BHN, HRB/HRC |

| <i>Type of Test</i> | <i>Position of the Samples and Direction of the Test Specimen ⁽¹⁾</i> | <i>Remarks</i> |
|--|---|--|
| Tensile test at room temperature | Both ends of product from top of first ingot Both ends of product from tail end of con-cast string Test – transverse ⁽²⁾ | Report 0.2% and 1.0% Proof Yield, Rm, Elongation, RA(%) |
| Tensile test at elevated temperature, if applicable 50°C, 75°C, 100°C | Both ends of product from top of first ingot Both ends of product from tail end of con-cast string Test – transverse ⁽²⁾ | Report 0.2% and 1.0% Proof Yield |
| Impact tests ⁽³⁾ specimens for grades: | Both ends of product from top of first ingot Both ends of product from tail end of con-cast string Test – longitudinal and transverse | Testing Temperature, °C (°F) |
| | | 0 (32) -196 (-320) |
| Corrosion test | Surface and cross section | ASTM A262, Program E Bend test (transverse) with 180 bend angle on 3t mandrel for information ASTM G48 or equivalent |
| If required, special corrosion test ⁽⁴⁾ | Surface and cross section | Report mass loss |
| Liquid penetrant test | Random spot checks | Check edges and suspect areas on surfaces. No cracks allowed. |
| Ultrasonic test | 100% of qualification products | ASTM A578 or equivalent |

Notes:

- 1 For hot rolled strips, see 2-A1/4.6.2.
- 2 Longitudinal directions for sections and plates having width less than 600 mm.
- 3 One set of 3 Charpy V-notch impact specimens is required for each impact test.
- 4 Special corrosion test is to be agreed in the particular application.
- 5 Hardness is to be tested for information.

TABLE 2
Tests for Rolled Duplex Stainless Steel Products Manufacturer Approval

| <i>Type of Test</i> | <i>Position of the Samples and Direction of the Test Specimen ⁽¹⁾</i> | <i>Remarks</i> |
|-----------------------|---|---|
| Chemical analysis (%) | - | Complete analysis from ladle and products including micro alloying and residual elements |
| Microstructure | Both ends of product from top of first ingot Both ends of product from tail end of con-cast string Test – longitudinal and transverse | ×100 and ×500 magnification at surface, one quarter and mid-thickness Determine ferrite phase percentage Determine ferrite delta content and detrimental phases (sigma) |

| <i>Type of Test</i> | <i>Position of the Samples and Direction of the Test Specimen ⁽¹⁾</i> | <i>Remarks</i> | | |
|--|---|---|--------------|-------------|
| Hardness ⁽⁵⁾ | Both ends of product from top of first ingot Both ends of product from tail end of con-cast string | BHN, HRB/HRC | | |
| Tensile test at room temperature | Both ends of product from top of first ingot Both ends of product from tail end of con-cast string Test – transverse ⁽²⁾ | Report Yield, Rm, Elongation, RA(%) | | |
| Impact tests ⁽³⁾ specimens for grades: | Both ends of product from top of first ingot Both ends of product from tail end of con-cast string Test – longitudinal and transverse | Testing temperature, °C (°F) | | |
| | | <table border="1"> <tr> <td>0 (32)</td> <td>-20 (-4)</td> <td>-40 (-40)</td> <td>-60 (-76)</td> </tr> </table> | 0 (32) | -20 (-4) |
| 0 (32) | -20 (-4) | -40 (-40) | -60 (-76) | |
| Corrosion test | Surface and cross section | ASTM A262, Program C, or equivalent Bend test (transverse) with 180 bend angle on 3t mandrel for information ASTM G48 or equivalent | | |
| If required, special corrosion test ⁽⁴⁾ | Surface and cross section | Report mass loss | | |
| Liquid penetrant test | Random spot checks | Check edges and suspect areas on surfaces. No cracks allowed. | | |
| Ultrasonic test | 100% of qualification products | ASTM A578 or equivalent | | |

Notes:

- 1 For hot rolled strips see, 2-A1/4.6.2.
- 2 Longitudinal directions for sections and plates having width less than 600 mm.
- 3 One set of 3 Charpy V-notch impact specimens is required for each impact test.
- 4 Special corrosion test is to be agreed in the particular application.
- 5 Hardness is to be tested for information.

4.7 Weldability Tests for Austenitic and Duplex Stainless Steels

4.7.1 General

Manufacturers are to provide welding procedure specifications and welding procedure qualification test reports to ABS for review.

For austenitic stainless steels, information on the weldability and any weldability test results are to be provided.

For duplex stainless steels, weldability tests are required as indicated below.

4.7.2 Preparation and Welding of the Test Assemblies

Weldability tests are required for plates and are to be carried out on samples of the thickest plate.

In general, the following tests are to be carried out:

- i) One (1) butt weld test assembly welded with a minimum heat input
- ii) One (1) butt weld test assembly welded with a maximum heat input

The butt weld test assemblies are to be prepared with the weld seam transverse to the plate rolling direction, so that impact specimens will be in the longitudinal direction.

The edge preparation is preferably to be 1/2 V or K.

As far as possible, the welding procedure is to be in accordance with the normal welding practice used at the yards for the type of steel in question.

The welding parameters including consumables designation and diameter, pre-heating temperatures, interpass temperatures, heat input, number of passes, etc. are to be reported.

4.7.3 Type of Tests

From the test assemblies, the following test specimens are to be taken.

4.7.3(a)

One cross weld tensile test.

4.7.3(b)

A set of three (3) Charpy V-notch impact specimen transverse to the weld with the notch located at the fusion line and at a distance 2 mm (0.08 in.), 5 mm (0.2 in.) and minimum 20 mm (0.8 in.) from the fusion line. The fusion boundary is to be identified by etching the specimens with a suitable reagent. The test temperature is to be the one prescribed for the testing of the steel grade in question. Charpy tests are to be carried out at -20°C (-4°F). If the steel mill wants to establish weldability toughness at lower temperatures, CVN tests are to be performed at a temperature below -20°C (-4°F).

4.7.3(c)

Hardness tests HV10 or HV5 across the weldment. The indentations are to be made along a 1 mm (0.04 in.) transverse line beneath the plate surface on both the face side and the root side of the weld as follows:

- Fusion line
- HAZ: at each 0.7 mm (0.028 in.) from fusion line into unaffected base material (6 to 7 minimum measurements for each HAZ)

The maximum hardness value is not to be higher than 2-1/Table 2.

A sketch of the weld joint depicting groove dimensions, number of passes, hardness indentations is to be attached to the test report, together with photo macrographs of the weld cross section.

4.7.4 Micrographic Examination

For duplex stainless steels, micrographic examination with $\times 500$ magnification are to be taken in the weld metal, HAZ and base metal along the weld root and cap. The microstructure is to be appropriately etched, examined and free from carbide and precipitate at grain boundaries. The ferrite percentage is to be determined in accordance with ASTM E562 or equivalent standard. The ferrite percentage is to be within 30% to 70%.

4.7.5 Corrosion Test at HAZ

For duplex stainless steel weldment, corrosion test is to be taken in the HAZ in accordance with ASTM G48 or equivalent for pitting corrosion.

- i) The test specimen is to be taken in as-welded condition after normal weld cleaning. Cut edges shall be prepared according to ASTM G48.
- ii) The test specimens are required to be full thickness. If grinding is performed, the surface is to be smooth without notches and the full thickness of base metal is to be maintained.

At least 25 mm (1 in.) along the weld and 50 mm (2 in.) across the weld are to be included.

- iii)* The whole specimen shall be pickled then weighed and tested. Pickling may be performed for 5 min. at 60°C (140°F) in a solution of 20% Nitric + 5% Hydrofluoric acid + Water.
- iv)* For 2205 duplex, the test specimens are to be exposed in ferric chloride solution for 24 hours at 20°C (68°F). Mass loss is to be reported.
- v)* For 2507 duplex, the test specimens are to be exposed in the ferric chloride solution for 24 hours at 50°C (122°F). Mass loss is to be reported.
- vi)* No pitting is allowed on specimen surface at ×20 magnification, and the general mass loss is expected to be less than 4 g/m².

4.8 Nondestructive Tests

The manufacturer is to present representative products for approval purpose and also other products from the current production. Furthermore, at the discretion of the ABS Surveyor, other products may be selected for examination and testing.

The following visual examination and nondestructive tests are to be carried out and submitted to ABS for review:

- i)* Surface inspection
- ii)* Dimensional check
- iii)* Nondestructive testing report

4.9 Other Tests

Other relevant tests carried out by the manufacturer are to be reported.

5 Results

Before the approval of the mill, all test results are evaluated for compliance with the Rules/Guides/Standards. Depending upon the evaluation, limitations or conditions of testing, as deemed appropriate, may be specified in the approval document.

All information required in 2-A1/3, applicable to the products submitted to the tests, is to be collected by the manufacturer and incorporated into a single document including all test results and operation records relevant to steel making, casting, rolling, heat treatment of the tested products, etc.

6 Certification for Stainless Steel Mill

6.1 Approval

Upon satisfactory completion of the survey and technical review, approval will be granted by ABS and a five-year certificate will be issued to the mill.

6.2 List of Approved Manufacturers

The approved manufacturers are entered into a list containing the types, dimensions of steel and the main conditions of approval.

7 Renewal of Approval

The approval is to remain valid for a maximum of five years, renewable subject to an audit and assessment of the result of satisfactory survey during the preceding period. The Surveyor's report confirming no process changes, along with mechanical property statistical data for various approved grades, is to be made available to the ABS for review and issuance of renewal letter/certificate.

Where for operational reasons, the renewal audit cannot be carried out within the validity of approval, the manufacturer will still be considered as being approved if agreement to such extension of audit date is provided for in the original approval. In such instance, the extension of approval will be backdated to the original renewal date.

Manufacturers who have not produced the approved grades and products during the period preceding the renewal may be required to carry out approval tests, unless the results of production of similar grades of products during the period are evaluated by ABS and found acceptable for renewal.

8 Withdrawal of the Approval

The approval may be withdrawn before the expiry of the validity period in the following cases.

- i)* In-service failures traceable to product quality
- ii)* Non conformity of the product revealed during fabrication and construction
- iii)* Discovery of failure of the manufacturer's quality system
- iv)* Changes made by the manufacturer, without prior agreement of ABS, to the extent of the approval defined at the time of the approval
- v)* Evidence of major non conformities during testing of the products

CHAPTER 2 Requirements for Stainless Steels

APPENDIX 2 Fatigue Properties of Stainless Steels (For Reference)

1 Scope

This Appendix covers fatigue characteristics, design fatigue strain range for 304 and 316 stainless steels, fracture morphology, prevention or mitigation of fatigue failure, and corrosion fatigue.

If required by ABS Rules or standards, a fatigue assessment is to be performed in accordance with the applicable methods or procedures, with appropriate adjustments for the stainless steel fatigue properties.

2 Reference Documents

API 571 : Damage Mechanisms Affecting Fixed Equipment in the Refining Industry

ASME BPVC II: Materials Part D-Properties

ASTM: Handbook Volume 19-Fatigue and Fracture

3 Fatigue Characteristics

Fatigue cracking is a material failure mechanism that occurs when material is exposed to cyclical stresses for an extended period, and may cause sudden and unexpected failure.

The cyclical stresses may result from either mechanical loading or thermal cycling with the stress typically much lower than the yield strength of the material.

i) Mechanical loading fatigue includes:

- High cycle fatigue damaged by the cyclic loading
- Low cycle fatigue damaged by the cyclic strain
- Vibration-induced fatigue damaged by the dynamic vibration loading

ii) Thermal cycling fatigue is caused by the temperature change or gradient with time to produce cyclic stresses in structure. Mechanical restraint and temperature change are two essential factors for thermal fatigue. Thermal stresses are caused by the thermal expansions and contractions against restrained endpoints. For thick sections, temperature gradients may develop through the thickness, as well as longitudinally, to cause tri-axial stresses.

4 Design

Materials properties (strength, hardness, microstructure), geometry, stress level, and number of cycles are the predominate factors in determining the fatigue resistance.

Fatigue failure includes fatigue crack initiation and propagation. Under cyclic loading or thermal cycling, fatigue cracks typically initiate on the surface at notches, weld toes, inclusions or other stress raisers. Design of a vessel, tool or component is the most important factor in determining the resistance to fatigue cracking. Common surface features that may lead to fatigue crack initiation are as follows.

- i)* Weld joints, flaws (inclusions or discontinuities), and/or misalignment
- ii)* Corrosion pits
- iii)* Mechanical notches (sharp corners, grooves)
- iv)* Key holes on drive shafts of rotating equipment
- v)* Thread root radius
- vi)* Markings

The design fatigue strain range is provided in ASME BPVC II, which is also included for reference in this document, 2-A2/Table 1 or 2-A2/Figure 1 for 304 stainless steel and 2-A2/Table 2 or 2-A2/Figure 2 for 316 stainless steel.

5 Fracture Morphology

Typically, fracture morphology includes crack initiation, propagation and fast fracture. The fatigue fracture surface displays “clam shell” type with concentric rings called “beach marks” from the crack initiation sites. This pattern results from the “waves” of crack propagation that occur during cycles above the threshold loading. These concentric cracks continue to propagate until the cross-sectional area is reduced to the point where the fast fracture occurs due to the overloading.

Cracks initiating from a surface stress concentration or defect will typically result in a single “clam shell” fatigue pattern, containing multiple benchmark striations. Cracks from cyclical overstress without significant stress concentrations will typically result in a fatigue failure with multiple nucleation points and multiple “clam shell” patterns.

6 Corrosion Fatigue

Corrosion fatigue is a type of fatigue damage through fluctuating stresses and a corrosive environment, with the damage occurring at lower stress levels or fewer cycles than in the absence of the corrosive environment.

For corrosion-fatigue cracking under a given operating environment, the relative contribution of stress and corrosion can vary significantly. The complexity of the interaction between the loading conditions, the metallurgical variables, and the environmental parameters can make it difficult to identify the root cause of the initial damage.

Corrosion-fatigue cracks typically begin at the material surface. In cases where there are near-surface defects, these can act as stress concentration sites, facilitating subsurface crack initiation. The damage can't be defined as corrosion fatigue unless the influence of corrosive environment is activated. Surface features observed at the origin of a corrosion-fatigue crack can vary depending upon the alloy and the influence of the environmental parameters. If failure occurs through corrosion fatigue, corrosion bi-products are generally found on most of the fracture surfaces. However, for failure analysis or investigation, it is challenging to determine when the corrosion bi-products are formed, for example before cracking, during cracking or after cracking.

7 Prevention or Mitigation

Fatigue analysis is performed to establish fatigue lives. Due to the uncertainties associated with fatigue prediction, safety factors are applied to produce conservative predictions, the following recommended practices are applicable to austenitic and duplex stainless steels, to reduce the possibility of, or prevent premature fatigue failure.

- i) The best practice is a good design to minimize stress concentration or mechanical restraint of parts in cyclic service
- ii) Selection of materials with a sufficient design fatigue life for its intended cyclic service
- iii) Allowance for a generous radius along edges and corners
- iv) Minimization of grinding marks, nicks and gouges on materials surfaces
- v) Good fit up, smooth transitions for welds and minimize weld defects
- vi) Removal of any burrs or lips caused by machining
- vii) Use of low stress stamps and marking tools

TABLE 1
Design Fatigue Strain Range, ϵ_p , for 304 Stainless Steel ⁽²⁾

| Number of Cycles, $N_a^{(1)}$ | Strain Range, ϵ_p , (inch/inch), at Temperature | | | | | | |
|-------------------------------|--|---------------|---------------|----------------|----------------|----------------|----------------|
| | 100°F (37°C) | 800°F (426°C) | 900°F (482°C) | 1000°F (538°C) | 1100°F (593°C) | 1200°F (649°C) | 1300°F (704°C) |
| 10 | 0.051 | 0.050 | 0.0465 | 0.0425 | 0.0382 | 0.0335 | 0.0297 |
| 20 | 0.036 | 0.0345 | 0.0315 | 0.0284 | 0.025 | 0.0217 | 0.0186 |
| 40 | 0.0263 | 0.0246 | 0.0222 | 0.0197 | 0.017 | 0.0146 | 0.0123 |
| 10 ² | 0.018 | 0.0164 | 0.0146 | 0.0128 | 0.011 | 0.0093 | 0.0077 |
| 2 × 10 ² | 0.0142 | 0.0125 | 0.011 | 0.0096 | 0.0082 | 0.0069 | 0.0057 |
| 4 × 10 ² | 0.0113 | 0.00965 | 0.00845 | 0.00735 | 0.0063 | 0.00525 | 0.00443 |
| 10 ³ | 0.00845 | 0.00725 | 0.0063 | 0.0055 | 0.0047 | 0.00385 | 0.00333 |
| 2 × 10 ³ | 0.0067 | 0.0059 | 0.0051 | 0.0045 | 0.0038 | 0.00315 | 0.00276 |
| 4 × 10 ³ | 0.00545 | 0.00485 | 0.0042 | 0.00373 | 0.0032 | 0.00263 | 0.0023 |
| 10 ⁴ | 0.0043 | 0.00385 | 0.00335 | 0.00298 | 0.0026 | 0.00215 | 0.00185 |
| 2 × 10 ⁴ | 0.0037 | 0.0033 | 0.0029 | 0.00256 | 0.00226 | 0.00187 | 0.00158 |
| 4 × 10 ⁴ | 0.0032 | 0.00287 | 0.00254 | 0.00224 | 0.00197 | 0.00162 | 0.00138 |
| 10 ⁵ | 0.00272 | 0.00242 | 0.00213 | 0.00188 | 0.00164 | 0.00140 | 0.00117 |
| 2 × 10 ⁵ | 0.0024 | 0.00215 | 0.0019 | 0.00167 | 0.00145 | 0.00123 | 0.00105 |
| 4 × 10 ⁵ | 0.00215 | 0.00192 | 0.0017 | 0.0015 | 0.0013 | 0.0011 | 0.00094 |
| 10 ⁶ | 0.0019 | 0.00169 | 0.00149 | 0.0013 | 0.00112 | 0.00098 | 0.00084 |

Notes:

- 1 Cyclic strain rate is 10⁻³/second.
- 2 ASME BPVC II Materials Part D-Properties.

FIGURE 1
Design Fatigue Strain Range, ϵ_p , for 304 Stainless Steel ^(1,2)

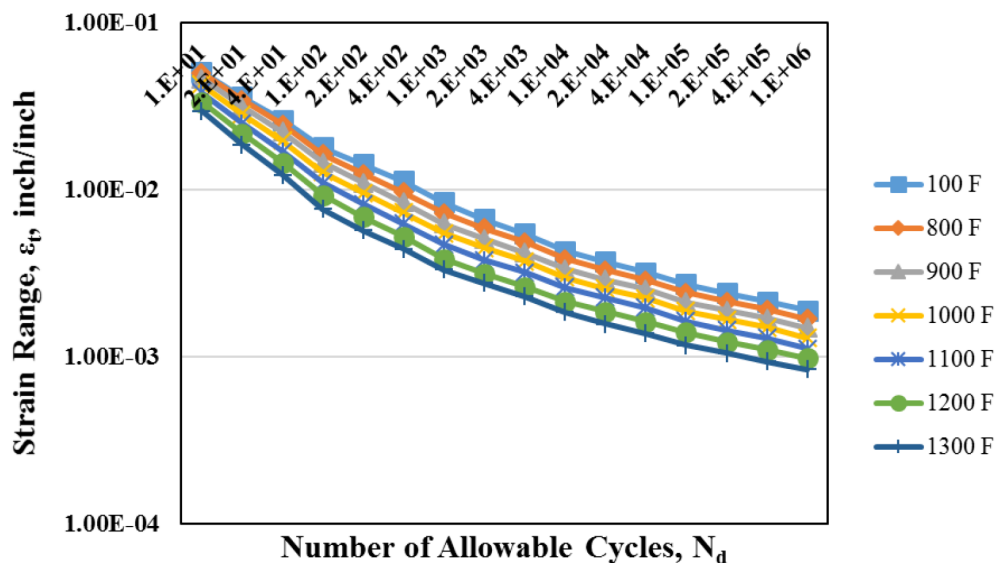

Notes:

- 1 Cyclic strain rate is 10⁻³/second.
- 2 ASME BPVC II Materials Part D-Properties.

TABLE 2
Design Fatigue Strain Range, ϵ_p , for 316 Stainless Steel ⁽²⁾

| Number of Cycles, N_d ⁽¹⁾ | Strain Range, ϵ_p (inch/inch), at Temperature | | | | |
|--|--|---------------|---------------|-------------------------|----------------|
| | 100°F (37°C) | 800°F (426°C) | 900°F (482°C) | 1000-1200°F (538-649°C) | 1300°F (704°C) |
| 10 | 0.0507 | 0.0438 | 0.0378 | 0.0318 | 0.0214 |
| 20 | 0.0357 | 0.0318 | 0.0251 | 0.0208 | 0.0149 |
| 40 | 0.026 | 0.0233 | 0.0181 | 0.0148 | 0.0105 |
| 10 ² | 0.0177 | 0.0159 | 0.0123 | 0.00974 | 0.00711 |
| 2 × 10 ² | 0.0139 | 0.0125 | 0.00961 | 0.00744 | 0.00551 |
| 4 × 10 ² | 0.0110 | 0.00956 | 0.00761 | 0.00574 | 0.00431 |
| 10 ³ | 0.00818 | 0.00716 | 0.00571 | 0.00424 | 0.00328 |
| 2 × 10 ³ | 0.00643 | 0.00581 | 0.00466 | 0.00339 | 0.00268 |
| 4 × 10 ³ | 0.00518 | 0.00476 | 0.00381 | 0.00279 | 0.00226 |
| 10 ⁴ | 0.00403 | 0.00376 | 0.00301 | 0.00221 | 0.00186 |
| 2 × 10 ⁴ | 0.00343 | 0.00316 | 0.00256 | 0.00186 | 0.00162 |
| 4 × 10 ⁴ | 0.00293 | 0.00273 | 0.00221 | 0.00161 | 0.00144 |
| 10 ⁵ | 0.00245 | 0.00226 | 0.00182 | 0.00136 | 0.00121 |
| 2 × 10 ⁵ | 0.00213 | 0.00196 | 0.00159 | 0.00121 | 0.00108 |

| Number of Cycles, $N_d^{(1)}$ | Strain Range, ϵ_p (inch/inch), at Temperature | | | | |
|-------------------------------|--|---------------|---------------|-------------------------|----------------|
| | 100°F (37°C) | 800°F (426°C) | 900°F (482°C) | 1000-1200°F (538-649°C) | 1300°F (704°C) |
| 4×10^5 | 0.00188 | 0.00173 | 0.00139 | 0.00109 | 0.000954 |
| 10^6 | 0.00163 | 0.00151 | 0.00118 | 0.000963 | 0.000834 |

Notes:

- 1 Cyclic strain rate is 10^{-3} /second.
- 2 ASME BPVC II Materials Part D-Properties.

FIGURE 2
Design Fatigue Strain Range, ϵ_p , for 316 Stainless Steel ^(1,2)

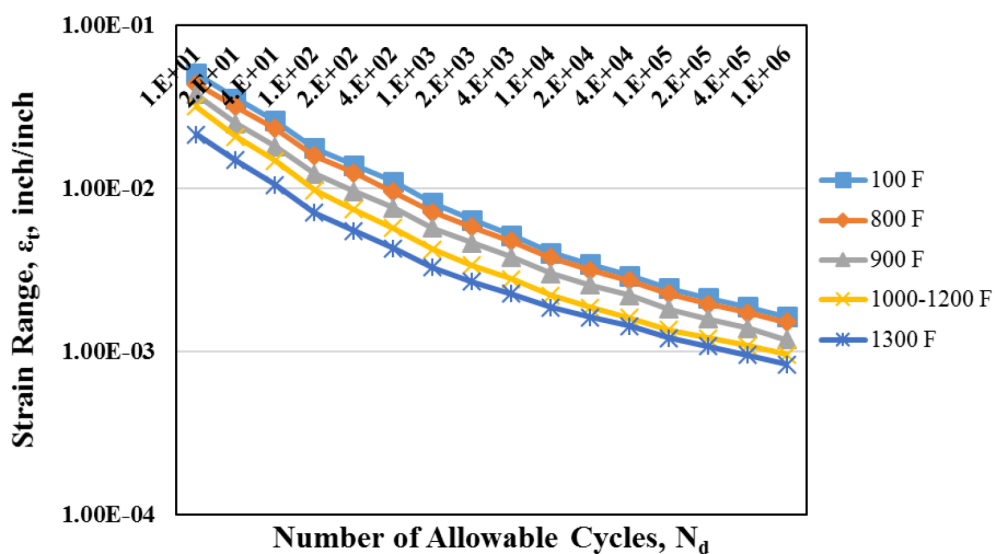

Notes:

- 1 Cyclic strain rate is 10^{-3} /second.
- 2 ASME BPVC II Materials Part D-Properties.

CHAPTER 2 Requirements for Stainless Steels

APPENDIX 3 Corrosion Properties of Stainless Steels (For Reference)

1 Scope

This Appendix provides general guidelines for high corrosion resistance of austenitic and ferritic-austenitic (duplex) stainless steels in marine and offshore applications. This Appendix provides the recommended practices for high corrosion resistance, uniform and localized corrosion, galvanic corrosion, pitting, crevice corrosion, intergranular corrosion, stress corrosion cracking and erosion-corrosion.

2 Reference Documents

API 571: Damage Mechanisms Affecting Fixed Equipment in the Refining Industry

ASME BPVC II: Materials Part D-Properties

ASTM G82: Standard Guide for Development and Use of a Galvanic Series for Predicting Galvanic Corrosion Performance

NACE: Corrosion Engineer's Reference Book, 2nd Edition, 1991

NiDI: Design Guidelines for the Selection and Use of Stainless Steel

3 Corrosion Resistance of Stainless Steels

There are many measures to protect base metal and mitigate corrosion failure, such as metal electro/electroless plating, non-metallic coating, cathodic protection, and controlled corrosion environments. However, under high temperature, high pressure and aggressive corrosion environments, the most effective measure to provide high corrosion resistance is by alloying.

The addition of chromium, nickel, and silicon can increase base metal electrode potential and enhance corrosion resistance. The addition of chromium in Iron forms a solid solution and the corrosion resistance increases abruptly when chromium mole percentage reaches 1/8, 2/8, ...n/8. Correspondingly, chromium weight percent is 11.6%, $11.6 \times 2\%$, $11.6 \times n\%$. Stainless steels typically have chromium content above 13% weight percent, which can contribute to the production of an adherent, uniform, thin passive oxide layer of chromium oxide on the surface of the stainless steels. This passive oxide film can improve corrosion resistance. The addition of nickel, Silicon and other alloy elements such as Mo, and nickel can also increase the corrosion resistance. However, nickel is expensive and silicon may cause steel brittleness when percent by weight is higher than 4-5%. Thus, chromium is the predominant element for high corrosion resistance of stainless steels.

The effects of alloy elements on stainless steels are summarized in 2-A3/Table 1 for information.

4 Uniform and Localized Corrosion

Uniform corrosion is the simplest form of environmental damage with a uniform amount of wall or thickness loss over a period of time. The corrosion rate is to be estimated by the dimension per unit of time such as mm (mils) per year.

The uniform corrosion of austenitic and duplex stainless steels corrodes the thin and invisible chromium oxide protective passive film on the surface. The passive film is stable and protective in normal atmospheric or mild aqueous environments and can be improved by adding higher amounts of chromium, molybdenum, nickel, or other alloy elements. Chromium can improve film stability. Molybdenum and chromium can increase resistance to chloride penetration. Nickel can enhance film resistance in some acid environments.

However, during construction, service or repair, the passive film of austenitic and duplex stainless steels may be damaged at small and well defined locations on the surface and localized corrosion can occur. A concern with the localized corrosion is that it is difficult to determine the seriousness of the attack until leakage happens. There are various types of corrosion mechanisms for localized corrosion.

5 Galvanic Corrosion

Galvanic corrosion typically occurs at the junction of dissimilar metals joined together in a suitable electrolyte such as a moist or aqueous environment.

For galvanic corrosion, three conditions are to be met:

- i)* Two different materials acting as anode and cathode, in contact with an electrolyte
- ii)* The presence of an electrolyte in fluid that can conduct current. Moisture or a separate water phase is usually required for the solution to have enough conductivity
- iii)* An electrical connection between anode and cathode

The more noble material (cathode) is protected by sacrificial corrosion of the more active material (anode). The anode corrodes at a higher rate than it would if it were not connected to the cathode. The relative galvanic series of alloys in seawater is shown in 2-A3/Table 2. The farther the alloys are apart in the table, the higher the driving force for galvanic corrosion.

The relative exposed surface area of the anode material and cathode material has a significant effect.

- i)* The corrosion rate of the anode may be high if there is a small anode-to-cathode ratio. The corrosion rate of the anode may be less affected if there is a large anode-to-cathode ratio.
- ii)* If the active material is coated, a large cathode-to-anode area may accelerate corrosion of the anode at any breaks of the coating.
- iii)* The same alloy may act as both anode and cathode due to surface films, scale, and/or local environment such as old steel pipe connected to new steel pipe.

Corrosion can be prevented or mitigated in several ways.

- i)* The best method is through good design.
- ii)* Differing alloys are not to be in intimate contact in conductive environments unless the anode/cathode surface area ratio is favorable.
- iii)* Coatings can be helpful.
- iv)* For piping, specially-designed electric insulating bolt sleeves and gaskets can eliminate the electrical connection.

- v) Galvanic corrosion is the principle used in galvanized steel, where the Zn corrodes preferentially to protect the underlying carbon steel. (If there is a break in the galvanized coating, a large anode to small cathode area prevents accelerated corrosion of the zinc steel). This anode-to-cathode relationship reverses at water temperatures over about 66°C (150°F).

More details related to galvanic corrosion are available in the ABS *Guidance Notes for Cathode Protection of Ships*.

6 Pitting

The passive film is typically stable and protective. Pitting may occur when the passive film is broken down in small isolated spots such as the surface is contacted by Halide salts. In the presence of oxygen in the environment, passive film can reform and continue to provide maximum protection. Otherwise, once pitting starts, the attack may accelerate because of differences in electric potential between the large area of passive film versus the small active pits.

For prevention and mitigation, the passive film should be protected in designing, manufacturing and service to avoid damage. Pitting may be avoided by appropriate materials selection depending upon service environments, such as grade 316 and 317 with Molybdenum for higher resistance in Chloride environment.

7 Crevice Corrosion

Crevice corrosion results from local differences in oxygen concentration associated with deposits on the metal surface, gaskets, lap joints or crevices under bolt or rivet heads where small amounts of liquid can be collected and become stagnant. The materials that form the crevice are not necessarily metallic. Wood, plastic, rubber, glass, concrete, living organisms etc. can also cause crevice corrosion. Once crevice corrosion starts, its progress is very rapid, especially in Chloride environments.

The best prevention and mitigation measure is by designing to eliminate crevices. In addition, stainless steels containing Molybdenum may be selected to mitigate the problem.

8 Intergranular Corrosion

Intergranular corrosion of austenitic and duplex stainless is a type of metallurgically influenced corrosion. Chromium may trend to form carbide at grain boundaries when stainless steels are heated or cooled through the temperature range 427-899°C (800-1650°F) for austenitic and 700-955°C (1300-1750°F) for duplex steels. This phenomenon is called chromium carbide precipitation or sensitization, which may result in the depletion of chromium and lower the corrosion resistance at and near the grain boundaries.

Sensitization may result from the slow cooling from annealing temperatures, stress relieving in the sensitization temperature range or welding. Depending upon the long or short time at the sensitization temperature range, the entire or partial piece of materials may be sensitized. Welding may form the sensitization bands in HAZ with a typical width of 3.175 mm (1/8 in.) to 6.35 mm (1/4 in.).

Depending on the magnitude of the sensitization and the aggressiveness of the environment, the following prevention measures may be taken, which are necessary only if the service environment is known to cause intergranular corrosion.

- i) Use austenitic and duplex stainless steels in the annealed or solution-treated condition
- ii) Select low carbon content stainless steels for welding and fabrication;
- iii) Select a stabilized austenitic grade such as grade 321 or 347 for service temperature in 427-899°C (800-1650°F). The protection for these grade is based on the addition of titanium and columbium with greater affinity with carbon;
- iv) Re-dissolve carbide by annealing or solution-treated after fabrication, which is not always practical during manufacturing.

- v) Thermal cycles may cause narrow bands of sensitization to form in the HAZ of stabilized grades, where titanium and columbium carbides dissolve and chromium carbides are able to form instead.

9 Stress Corrosion Cracking (SCC)

Stress corrosion cracking is a type of damage that requires the simultaneous action of a corrodent at a critical concentration and a sustained tensile stress with sufficient magnitude on a susceptible material for the stress corrosion cracking to occur. The elimination of any one of these three factors can completely remove or significantly reduce the susceptibility to SCC.

Chloride SCC is common for austenitic stainless steels. The 18–8 type alloys, such as 304 and 316, are the most susceptible and can suffer SCC in environments with local high chloride concentrations and temperature exceeding 60°C (140°F). Susceptibility can be reduced by alloy substitution. Typically, higher nickel austenitic and duplex stainless steels are less susceptible.

There are three basic forms of SCC:

- i) *Transgranular Stress Corrosion Cracking (TGSCC)*. TGSCC is generally associated with higher stress levels with cracks beginning at the surface such as pits and growing into the material in a continually branching mode.
- ii) *Intergranular Stress Corrosion Cracking (IGSCC)*. IGSCC typically occurs near welds such as heat affected zones or base metal, where material has been subjected to a certain level of heat and has changed the material microstructure, such as sensitization. The corrosion resistance at or near grain boundaries is degraded and shows lower corrosion resistance. Due to the residual stresses from welding or applied service loads, IGSCC may develop in corrosive environments.
- iii) *Irradiation-assisted Stress Corrosion Cracking (IASCC)*. IASCC is a special form of SCC with a high level of neutron bombardment as the source or the driving force for the cracking to form, for example, austenitic stainless steels used in the core region of a nuclear reactor.

Under some conditions, SCC in materials may propagate in a mixed TGSCC/IGSCC mode of fracture.

The following prevention or mitigation measures may be taken for SCC:

- i) Select SCC resistant materials. Nickel-base alloys have higher SCC resistance than duplex stainless steels, which is better than austenitic stainless steels.
- ii) Use low Chloride content water and dry out thoroughly and quickly following hydrotesting.
- iii) Apply coating as water barrier, such as Al foil or thermal sprayed Al, and optimize design to avoid Chloride in stagnant regions under insulation.
- iv) Stress relieve appropriately.

10 Erosion-Corrosion

There are mechanically assisted corrosion mechanisms such as velocity-affected corrosion, impingement corrosion, corrosion fatigue, erosion/fretting corrosion, etc. Erosion-corrosion is to be considered for marine and offshore application of stainless steels.

Erosion-corrosion is the damage to metals that occurs when particles transported in liquid impinge on the material surface and remove the protective film. The exposed fresh metal surfaces are anodic to the neighboring protected surfaces and results in rapid localized corrosion. The attacked areas are typically grooves, channels, or other surface penetrations that reflect the fluid velocity direction pattern. Nearly all flowing or turbulent corrosive fluids can cause erosion-corrosion.

Metal loss rates depend on the velocity and concentration of the impacting medium (e.g., particles, liquids, droplets, slurries, two-phase flow), the size and hardness of impacting particles, the hardness and corrosion resistance of the material subject to erosion, and the angle of impact.

- i) Softer alloys such as copper and aluminum alloys are easily worn from mechanical damage and severe metal loss may occur under high velocity conditions. The increasing hardness of the metal substrate may be a common approach to minimize damage, however, it is not always a good indicator of improved resistance to erosion depending upon the materials failure mechanism during erosion-corrosion.
- ii) Typically, metal loss is produced above a threshold velocity. Increasing velocities above this threshold may result in a higher metal loss rate.
- iii) The size, shape, density and hardness of the impacting medium affects the metal loss rate.
- iv) Increasing the corrosivity of the environment may reduce the stability of protective surface films and increase the susceptibility to metal loss. Metal may be removed from the surface as dissolved ions, or as solid corrosion products which are mechanically swept from the metal surface. Factors contributing to an increase in corrosivity of the environment, such as temperature, PH, etc., can increase susceptibility to metal loss.

The following prevention or mitigation measures may be taken for erosion/fretting corrosion:

- i) Improve design involving changes in shape, geometry and materials selection. For example, increasing the pipe diameter to decrease velocity, streamlining bends to reduce impingement, and increasing the wall thickness, using replaceable impingement baffles.
- ii) Improve erosion resistance through increasing substrate hardness, such as hardfacing or surface-hardening treatments.
- iii) Select more corrosion-resistant alloys and alter the process environment to reduce corrosivity, for example, deaeration, condensate injection or the addition of inhibitors.

TABLE 1
Effect of Alloy Elements on Stainless Steels

| | |
|------------|---|
| Carbon | C is traditionally the alloying element that is used to control the strength of the steel. In the case of stainless steels, the carbon content is kept extremely low in order to maintain both the weldability and the corrosion resistance. For standard grades AISI 316 carbon is max. 0.08% and for low carbon grades ATSI 316L carbon is max. 0.03%. At elevated temperatures the carbon may diffuse into the grain boundaries where chromium carbides are formed. This must be avoided, otherwise grain boundary corrosion may occur. |
| Chromium | Cr is the main element in stainless steels as chromium builds the passivating chromium-oxide layer that protects the steel. For austenitic and duplex, the chromium content is typically above 13%, and mostly, between 16 to 18%, in some grades even higher for some duplex. <i>Note: Cr content may be down to 11% for Ferritic grades.</i> |
| Nickel | Ni is mainly added in order to achieve the desired structure, which is important to promote and stabilize austenite. With a sufficiently high content of nickel, the steel achieves its austenitic structure. This will, compared with the pure chromium steels, change the mechanical properties considerably, increasing ductility and formability, improving weldability, etc. In the trade the austenitic steels are often referred to as 18-8-steels, 18% Cr, 8% Ni but modern types tends to have an increasing content of nickel and should therefore be referred to as 18-10 or 18-12 steels. |
| Molybdenum | Mo promotes the formation of ferrite. It increases the corrosive resistance considerably, particularly against pitting corrosion in seawater. Above 2.5% and up to 3% Mo is necessary to improve pitting resistance, but several standards require 2-3% and thus, allows close to 2% Molybdenum which may give too little resistance to crevice- and pitting-corrosion. Stainless steels for chemical tankers should always be alloyed with sufficient Molybdenum. AISI 317L has a content of molybdenum between 3-4%, which increases the corrosion resistance considerably. |

| | |
|----------------------------|--|
| Silicon | Si promotes the formation of ferrite, and also increases the scaling resistance of Cr-Ni austenitic steels in hot oxidizing gases. It has a similar effect to chromium in promoting the formation of the ferrite phase. Excessive silicon increases the hot-cracking tendency of austenitic steels, consequently the amount present must be limited to avoid cracking during welding. Silicon is particularly valuable in high nickel steels. |
| Manganese | Mn is another austenite stabilizer. Nickel can be replaced partially or completely by manganese. There are chromium-manganese and chromium-nickel-manganese steels, usually duplex with austenite predominating. They are just as readily weldable as the straight chromium-nickel steels. However, the fumes from welding are toxic. |
| Nitrogen | N in quantities between 0.08 and 0.2% is added in order to increase the strength of austenitic steels. Yield strength may be raised. Nitrogen is a strong austenite former, being thirty times stronger than nickel. 0.2% N equals 6% nickel as an austenite former. Nitrogen alloyed steels will, for this reason, have a somewhat lower nickel content to avoid too pure austenitic structure that may cause cracking problems during welding. |
| Niobium, titanium tantalum | Nb, Ti and Ta can stabilize stainless steels but are not needed for low carbon grades. |

TABLE 2
Galvanic Series of Metals Exposed to Seawater ^(1,2)

Corroded End Anodic—More Active

- Magnesium
- Magnesium alloys
- Zinc
- Aluminum
- Aluminum alloys
- Steel
- Cast iron
- Type 410 SS (active state)
- Type 304 SS (active state)
- Type 316SS (active state)
- Lead
- Tin
- Nickel (Active)
- Brass
- Copper
- Bronze
- Nickel (passive state)
- Monel
- Type 410 SS (passive state)
- Titanium
- Type 304 SS (passive state)

Type 316 SS (passive state)

Silver

Graphite

Gold

Platinum

Protected End—Cathode – More Noble

Notes:

- 1 Galvanic series of metal are from NACE Corrosion Engineer's Reference Book;
- 2 Galvanic series may be slightly different from different standards, such as API 571.

CONTENTS

| | | | |
|----------------|----------|--|-----------|
| SECTION | 1 | Application of Stainless Steel Welding Filler Metals..... | 94 |
| | 1 | Scope..... | 94 |
| | 2 | Reference Documents..... | 94 |
| | TABLE 1 | Suggested Base Metal and Filler Metal Combinations for Welding Austenitic and Ferritic-Austenitic Duplex Stainless Steels ⁽¹⁾ | 95 |
| | TABLE 2 | Austenitic and Ferritic-Austenitic Duplex Stainless Steel Welding Filler Metals for ASTM Pipes of Matching Designation | 95 |
| SECTION | 2 | Approval of Stainless Steel Welding Filler Metals..... | 97 |
| | 1 | Scope..... | 97 |
| | 1.1 | Condition of Approval..... | 97 |
| | 1.2 | Approval Procedure | 97 |
| | 2 | Reference Documents..... | 97 |
| | 3 | Grading..... | 98 |
| | 3.1 | ABS Grades | 98 |
| | 3.2 | Other Standards | 99 |
| | 3.3 | Special Properties | 99 |
| | 4 | Manufacturer’s Guarantee | 99 |
| | 5 | Plant Inspection | 99 |
| | 5.1 | Initial Inspection | 99 |
| | 5.2 | Annual Inspection | 99 |
| | 6 | Approval Tests..... | 99 |
| | 7 | Welding Conditions..... | 99 |
| | 8 | Chemical Analysis..... | 99 |
| | 9 | Deposited Metal Tension Test | 99 |
| | 10 | Butt Weld Tension Test | 100 |
| | 11 | Impact Test | 100 |
| | 12 | Butt Weld Bend Test | 100 |
| | 13 | Special Tests | 100 |

| | | |
|---------|--|-----|
| 13.1 | Nondestructive Testing | 100 |
| 13.2 | Microstructure Examination..... | 100 |
| 13.3 | Corrosion Test..... | 101 |
| 13.4 | Additional Tests | 101 |
| 14 | Licensee Approvals | 101 |
| 15 | Annual Check Tests | 101 |
| 16 | Quality Assurance Program | 101 |
| 17 | Retests | 101 |
| 18 | Package..... | 101 |
| 19 | Inspection..... | 102 |
| 20 | Acceptance..... | 102 |
| 21 | Marking of Package..... | 102 |
| 22 | Documentation..... | 102 |
| TABLE 1 | Chemical Composition for Austenitic and Ferritic- Austenitic Duplex Stainless Steel Welding Filler Metals.... | 103 |
| TABLE 2 | Mechanical Property Requirements ⁽¹⁾ | 104 |

1 Scope

Welding filler metals for austenitic and ferritic-austenitic (duplex) stainless are to be approved in accordance with this Chapter.

The suggested filler metals for austenitic and duplex stainless steels are listed in 3-1/Table 1.

The applicable filler metals for austenitic and duplex stainless steel pipes are listed in 3-1/Table 2.

The application of welding consumables for austenitic and duplex stainless steels are to be in accordance with manufactures recommendations with consideration being given to the corrosion resistance, strength and welding metallurgy.

Note:

The application of ferritic, martensitic and precipitation hardened stainless steels are to be in accordance with the applicable recognized industry standards and submitted to ABS for review.

2 Reference Documents

AWS A5.4: Specification for Stainless Steel Electrodes for Shielded Metal Arc Welding

AWS A5.9: Specification for Bare Stainless Steel Welding Electrodes and Rods

AWS A5.22: Specification for Stainless Steel Flux Cored and Metal Cored Welding Electrodes and Rods

AWS A5.30: Specification for Consumable Inserts

AWS D1.6: Structural Welding Code-Stainless Steel

TABLE 1
Suggested Base Metal and Filler Metal Combinations for Welding Austenitic and Ferritic-Austenitic Duplex Stainless Steels ⁽¹⁾

| <i>Base Metal</i> | | | | | | | | | | | | | |
|-------------------|-----|------|------|------|------|------|------|------|--|--|------|------|------|
| <i>Base Metal</i> | 304 | 304L | 316 | 316L | 317 | 317L | 321 | 347 | | | 2205 | 2304 | 2507 |
| 304 | 308 | 308L | 308 | 308L | 308 | 308 | 308 | 308 | | | 308 | 308L | 308L |
| 304L | - | 308L | 308L | 308L | 308L | 308L | 308L | 308L | | | 308L | 308L | 308L |
| 316 | - | - | 316 | 316L | 316 | 316L | 347 | 316 | | | 316L | 316L | 316L |
| 316L | - | - | - | 316L | 316L | 316L | 347 | 316L | | | 316L | 316L | 316L |
| 317 | - | - | - | - | 317 | 317L | 347 | 316 | | | 317L | 317L | 317L |
| 317L | - | - | - | - | - | 317L | 347 | 316L | | | 317L | 317L | 317L |
| 321 | - | - | - | - | - | - | 347 | 347 | | | 308 | 308L | 308L |
| 347 | - | - | - | - | - | - | - | 347 | | | 308 | 308L | 308L |
| 2205 | - | - | - | - | - | - | - | - | | | 2209 | 2209 | 2209 |
| 2304 | - | - | - | - | - | - | - | - | | | - | 2209 | 2209 |
| 2507 | - | - | - | - | - | - | - | - | | | - | - | 2593 |

Note:

- Other base steel and filler metal combinations can be applied, provided the combination is metallurgically, mechanically and corrosively acceptable and approved by ABS.

TABLE 2
Austenitic and Ferritic-Austenitic Duplex Stainless Steel Welding Filler Metals for ASTM Pipes of Matching Designation

| <i>Type</i> | <i>UNS</i> | <i>AWS Stainless Steel Welding Filler Classification</i> | | | | | | | |
|-----------------------------|------------|--|------------|------------------|-------------------|---------------------|------------|---------------------|------------|
| | | <i>A5.4/A5.4M</i> | | <i>A5.9/5.9M</i> | | <i>A5.22/A5.22M</i> | | <i>A5.30/A5.30M</i> | |
| | | <i>Type</i> | <i>UNS</i> | <i>Type</i> | <i>UNS</i> | <i>Type</i> | <i>UNS</i> | <i>Type</i> | <i>UNS</i> |
| Austenitic Stainless Steels | | | | | | | | | |
| 304 | S30400 | E308 | W30810 | ER308 | S30880 | E308T | W30831 | IN308 | S30880 |
| 304L | S30403 | E308L | W30813 | ER308L | S30883 | E308LT | W30835 | IN308L | S30883 |
| 316 | S31600 | E316 | W31610 | ER316 | S31680/ W31640 | E316T | W31631 | IN316 | S31680 |
| 316L | S31603 | E316L | W31613 | ER316L | S31683 | E316LT | W31635 | IN316L | S31683 |
| 317 | S31700 | E317 | W31710 | ER317 | S31780 | E317LT | W31735 | - | - |
| 317L | S31703 | E317L | W34713 | ER317L | S31783 | E317LT | W31735 | - | - |
| 321 | S32100 | E347 | W34710 | ER321/ ER347 | S32180/ S34780 | E347T | W34731 | IN348 | S34780 |
| 347 | S34700 | E347 | W34710 | ER347 | S34780 | E347T | W34731 | IN348 | S34780 |

| Type | UNS | <i>AWS Stainless Steel Welding Filler Classification</i> | | | | | | | |
|-------------------------|--------|--|------------|------------------|------------|---------------------|------------|---------------------|------------|
| | | <i>A5.4/5.4M</i> | | <i>A5.9/5.9M</i> | | <i>A5.22/A5.22M</i> | | <i>A5.30/A5.30M</i> | |
| | | <i>Type</i> | <i>UNS</i> | <i>Type</i> | <i>UNS</i> | <i>Type</i> | <i>UNS</i> | <i>Type</i> | <i>UNS</i> |
| Duplex Stainless Steels | | | | | | | | | |
| - | S31803 | E2209 | W39209 | ER2209 | S39209 | E2209TOX | W39293 | - | - |
| 2205 | S32205 | E2209 | W39209 | ER2209 | S39209 | E2209TOX | W39293 | - | - |
| 2507 | S32750 | E2594 | W39594 | ER2594 | S32750 | - | - | - | - |

Note:

- 1 Other base steel and filler metal combinations can be applied, provided the combination is metallurgically, mechanically and corrosively acceptable and approved by ABS.

CHAPTER 3

Stainless Steel Welding Filler Metals

SECTION 2

Approval of Stainless Steel Welding Filler Metals

1 Scope

In general, the requirements defined in Appendix 2-A2-1 of the *ABS Rules for Materials and Welding (Part 2)* are to be applied, unless there are specific requirements for approval of stainless steel welding filler metals in this document.

The requirements defined in Appendix 2-A2-2 of the *ABS Rules for Materials and Welding (Part 2)* are to be applied for the approval of stainless steel welding filler metals for shield metal arc welding, if applicable.

The requirements defined in Appendices 2-A2-3 and 2-A2-4 of the *ABS Rules for Materials and Welding (Part 2)* are to be applied for the approval of stainless steel flux cored wire/rod filler metals for flux cored arc welding and gas tungsten arc welding, if applicable.

The requirements defined in Appendix 2-A2-4 of the *ABS Rules for Materials and Welding (Part 2)* are to be applied for the approval of bare stainless steel welding electrodes and rods for gas metal arc welding, if applicable.

1.1 Condition of Approval

The scope and conditions of classification contained in Part 1, Chapter 1 of the *ABS Rules for Conditions of Classification (Part 1)* are applicable to the approval of welding filler metals, insofar as they are appropriate. Approval will be for each plant of each manufacturer carrying out its own quality control inspection and certification.

1.2 Approval Procedure

The general requirements for approval procedure are defined in 2-A2-1/1.3 of the *ABS Rules for Materials and Welding (Part 2)*.

2 Reference Documents

ASTM E353: Standard Test Methods for Chemical Analysis of Stainless, Heat Resisting, Maraging and Other Similar Chromium-Nickel-Iron Alloys

ASTM E562: Standard Test Method for Determining Volume Fraction by Systematic Manual Point Count

AWS A5.1: Procurement Guidelines for Consumables-Welding and Allied Processes-Flux and Gas Shielded Electrical Welding Processes

AWS A5.4: Stainless Steel Electrodes for Shielded Metal Arc Welding

AWS A5.9: Specification for Bare Stainless Steel Welding Electrodes and Rods

AWS A5.22: Stainless Steel Electrodes for Flux Cored Arc Welding & Stainless Steel Flux Cored Rods for Gas Tungsten Arc Welding

AWS A5.30: Specification for Consumable Inserts

AWS D1.6: Structural Welding Code-Stainless Steel

3 Grading

3.1 ABS Grades

Corresponding to the AWS designation of the weld filler metals, welding consumables intended for austenitic stainless steel welding are as follows⁽¹⁾:

- 308, 308L, 308Mo
- 309, 309L, 309Mo
- 310, 310Mo
- 312
- 316, 316L
- 317, 317L
- 318
- 330
- 347

The additional LT is to be added, provided that the CVN test can meet the requirements at the temperature of -196°C (-320°F).

Corresponding to the AWS designation of the weld filler metals, welding consumables intended for ferritic-austenitic (duplex) stainless steel welding are as follows:

- 2209
- 2307
- 2533
- 2594

Notes:

- 1 LT is to be added, provided that the CVN test can meet the requirements 27 J (20 ft-lbf) at a temperature of -196°C (-320°F).
- 2 The welding filler metals may be produced in ferritic, martensitic and precipitation hardened stainless steels in accordance with the applicable recognized industry standards and submitted to ABS for review.

3.2 Other Standards

At the option of the manufacturer, filler metals may be approved to a recognized standard. The required tests and procedures for such approval are to be in accordance with the specified standard. In addition, annual inspection and testing are to be carried out for continued approval.

3.3 Special Properties

Welding filler metals may be approved to the manufacturer's guaranteed minimum properties which might be over and above, the requirements of the applicable standard. Notations indicating guaranteed minimum properties will be added, as appropriate, upon verification by test.

4 Manufacturer's Guarantee

The general requirements for manufacturer's guarantee are defined in 2-A2-1/5 of the *ABS Rules for Materials and Welding (Part 2)*.

5 Plant Inspection

5.1 Initial Inspection

The general requirements for plant inspection are defined in 2-A2-1/7.1 of the *ABS Rules for Materials and Welding (Part 2)*.

5.2 Annual Inspection

The general requirements for annual inspection are defined in 2-A2-1/7.3 of the *ABS Rules for Materials and Welding (Part 2)*.

6 Approval Tests

The general requirements defined in 2-A2-1/5 and approval tests defined in Appendices 2-A2-2, 2-A2-3, and 2-A2-4 of the *ABS Rules for Materials and Welding (Part 2)* are to be applied depending upon the welding technique, unless there are specific test requirements for approval of stainless steel welding filler metals in this document.

- i) The sample for welding filler metals are not to be post heat treated, unless otherwise required.
- ii) For all-deposited-metal, the weld test samples are to be prepared using the applicable grade of stainless steels. At the request of the manufacturer and agreed by the ABS Surveyor, the all-weld-metal tests may be deposited on carbon and carbon-manganese base steels, provided that the bevel is buttered sufficiently using the welding consumable to prevent the base metal dilution into the weld metal from where the tests are to be taken.

7 Welding Conditions

The general requirements for welding conditions are defined in 2-A2-1/11 of the *ABS Rules for Materials and Welding (Part 2)*, unless specified otherwise by the applicable standard.

8 Chemical Analysis

The chemical analysis of the deposited weld metal is to be supplied by the manufacturer and is to include the content of all significant alloying elements (e.g., those identified in an AWS filler metals specification). Results of the analysis are not to exceed the limit values in 3-2/Table 1 or other recognized standard, the narrower tolerances being applicable in each case.

9 Deposited Metal Tension Test

The requirements for deposited metal tension testing defined in 2-A2-1/15 of the *ABS Rules for Materials and Welding (Part 2)* are to be applied.

The requirements defined in Appendices 2-A2-2, 2-A2-3, and 2-A2-4 of the *ABS Rules for Materials and Welding (Part 2)* are also to be applied depending upon the welding technique.

Two longitudinal tensile tests are to be carried out. The values of tensile strength and elongation are to be recorded and conform to the applicable requirements of 3-2/Table 2 or other recognized standard.

Note: Yield strength is not specified and is to be reported for information.

10 Butt Weld Tension Test

The requirements for butt weld tension testing defined in 2-A2-1/17 of the *ABS Rules for Materials and Welding (Part 2)* are to be applied.

The requirements defined in Appendices 2-A2-2, 2-A2-3, and 2-A2-4 of the *ABS Rules for Materials and Welding (Part 2)* are also to be applied depending upon the welding technique.

Tension test results are to conform to the requirements of 3-2/Table 2. The position of the fracture is to be reported.

11 Impact Test

The requirements for impact testing and retesting for all-weld-metal and butt welds defined in 2-A2-1/19 of the *ABS Rules for Materials and Welding (Part 2)* are to be applied.

The average value of three specimens is to equal or exceed the required average value, according to the applicable grade and welding technique. Only one individual value may be below the required average value, provided it is not less than 70% of the required average value.

- i) For all-weld-metal and butt weld tests, the minimum average CVN is 27 J (20 ft-lbf) at the requested test temperature, generally -20°C (-4°F). Lower temperature CVN test may be considered.
- ii) For austenitic stainless steel welding consumables, intended for the LT symbol, the minimum average CVN is 27 J (20 ft-lbf) at -196°C (-320°F).

12 Butt Weld Bend Test

The requirements for butt weld bend testing defined in 2-A2-1/21 of the *ABS Rules for Materials and Welding (Part 2)* are to be applied.

The requirements defined in Appendices 2-A2-2, 2-A2-3, and 2-A2-4 of the *ABS Rules for Materials and Welding (Part 2)* are also to be applied depending upon the welding technique.

Unless otherwise agreed, the test specimens are to be bent through an angle of 120 degrees around a mandrel with the diameter of three times of the specimen thickness.

13 Special Tests

13.1 Nondestructive Testing

The welded assemblies may be subjected to radiographic or ultrasonic examination to ascertain any discontinuities in the weld prior to testing.

13.2 Microstructure Examination

For duplex welding filler metals, the ratio of ferrite/austenite is to be determined in the deposited material in accordance with ASTM E562. The average ferrite content is to be between 30% and 70%.

13.3 Corrosion Test

Unless otherwise agreed, intergranular corrosion in accordance with ASTM A262 or equivalent is to be performed for butt welds using austenitic stainless steel welding filler.

At the discretion of ABS, corrosion tests in accordance with ASTM A262, ASTM G48 or equivalent may be required for butt welds using duplex stainless steel welding filler metals.

Specialized corrosion tests may be requested if the consumable designation has additional corrosion requirements or special corrosive environments.

13.4 Additional Tests

Depending upon the standard applied, ABS may request additional tests, as deemed necessary.

14 Licensee Approvals

The requirements for licensee approvals defined in 2-A2-1/27 of the *ABS Rules for Materials and Welding (Part 2)* are to be applied.

15 Annual Check Tests

The requirements for quality assurance program defined in 2-A2-1/29 of the *ABS Rules for Materials and Welding (Part 2)* are to be applied.

For annual control test, the following approval tests are to be required for stainless steel welding consumables.

- i) Chemical composition of deposited metal.
- ii) CVN tests at the -196°C (-320°F) for the austenitic stainless steel welding consumables intended for LT designation.

Depending upon the annual production and the ABS surveyor's extent of satisfaction, the additional approval tests may be carried out.

- i) Mechanical properties required in Appendices 2-A2-2, 2-A2-3, and 2-A2-4 of the *ABS Rules for Materials and Welding (Part 2)*.
- ii) Corrosion properties required for the austenitic and duplex stainless steel weldment.

16 Quality Assurance Program

The requirements for quality assurance program defined in 2-A2-1/31 of the *ABS Rules for Materials and Welding (Part 2)* are to be applied.

17 Retests

The requirements for retests defined in 2-A2-1/33 of the *ABS Rules for Materials and Welding (Part 2)* are to be applied.

18 Package

A standard package is to be agreed upon the purchaser and supplier. Supplier is to confirm the welding filler metal is marked with identification and is traceable to the unique product type of the manufacturer. Filler metals are to be suitably packed against damage during shipment and storage under normal conditions.

19 Inspection

All welding filler metals are to have a smooth finish free from slivers, depressions, scratches, scale, seams, laps and foreign matter that would adversely affect the welding characteristics, the operation of the welding equipment or the properties of the weld metal.

The core ingredients in metal-cored filler metals are to be distributed uniformly throughout the length of the electrode and the distribution is not to adversely affect the performance of the electrode or the properties of the weld metal.

The slit edges of strip electrodes are to be free from burrs exceeding 5% of the strip thickness. The tolerance in dimensions and weights are to be in accordance with AWS 5.4, 5.9, 5.22 or equivalent.

20 Acceptance

The acceptance of the materials is to be in accordance with the provisions of AWS A5.1, ISO 14344 or the equivalent industry standards.

21 Marking of Package

The product information is to be marked for each unit package:

- i)* AWS specification and AWS grade
- ii)* LT, if CVN at -196°C (-320°F) is qualified for austenitic stainless steels
- iii)* Supplier's name and trade designation
- iv)* Size and net weight
- v)* Heat Number
- vi)* Lot Number if it is practical
- vii)* Control

22 Documentation

Type and UNS designation are to be applied to the packing. The supplier is to confirm the products meet the requirements specified in this Section. The Material Test Report (MTR) is to include:

- i)* Purchaser's name and order number
- ii)* Name of manufacturers
- iii)* AWS specification and grade/classification designation to the packaging
- iv)* LT, if CVN at -196°C (-320°F) is qualified for austenitic stainless steels
- v)* Description and dimensions of the wire or rods
- vi)* Manufacturing process and Condition of supply
- vii)* Heat Number or Identification
- viii)* Lot Number if it is practical
- ix)* Chemical composition
- x)* Mechanical properties if it is practical
- xi)* Corrosion properties if it is required
- xii)* Address to which material is dispatched
- xiii)* Contract number for the material planned to use, if available

TABLE 1
Chemical Composition for Austenitic and Ferritic-Austenitic Duplex Stainless Steel Welding Filler Metals

| Type | UNS | Chemical Composition, wt. % ⁽¹⁾⁽⁴⁾ | | | | | | | | | | |
|--|--------|---|-----------|-----------|-----------|---------|-------------------|------|------|-----------|------|----------------|
| | | C | Cr | Ni | Mo | Mn | Si ⁽²⁾ | P | S | N | Cu | Other |
| Welding Electrodes and Rods for Austenitic Stainless Steels | | | | | | | | | | | | |
| 308 | S30880 | 0.08 | 19.5-22.0 | 9.0-11.0 | 0.75 | 1.0-2.5 | 0.30-0.65 | 0.03 | 0.03 | - | 0.75 | - |
| 308L | S30883 | 0.03 | 19.5-22.0 | 9.0-11.0 | 0.75 | 1.0-2.5 | 0.30-0.65 | 0.03 | 0.03 | - | 0.75 | - |
| 308Mo | S30882 | 0.08 | 18.0-21.0 | 9.0-12.0 | 2.00-3.00 | 1.0-2.5 | 0.30-0.65 | 0.03 | 0.03 | - | 0.75 | - |
| 309 | S30980 | 0.12 | 23.0-25.0 | 12.0-14.0 | 0.75 | 1.0-2.5 | 0.30-0.65 | 0.03 | 0.03 | - | 0.75 | - |
| 309L | S30983 | 0.03 | 23.0-25.0 | 12.0-14.0 | 0.75 | 1.0-2.5 | 0.30-0.65 | 0.03 | 0.03 | - | 0.75 | - |
| 309Mo | S30982 | 0.12 | 23.0-25.0 | 12.0-14.0 | 2.00-3.00 | 1.0-2.5 | 0.30-0.65 | 0.03 | 0.03 | - | 0.75 | - |
| 309LMo | S30986 | 0.03 | 23.0-25.0 | 12.0-14.0 | 2.00-3.00 | 1.0-2.5 | 0.30-0.65 | 0.03 | 0.03 | - | 0.75 | - |
| 310 | S31080 | 0.08-0.15 | 25.0-28.0 | 20.0-22.5 | 0.75 | 1.0-2.5 | 0.30-0.65 | 0.03 | 0.03 | - | 0.75 | - |
| 312 | S31380 | 0.15 | 28.0-32.0 | 8.0-10.5 | 0.75 | 1.0-2.5 | 0.30-0.65 | 0.03 | 0.03 | - | 0.75 | - |
| 316 | S31680 | 0.08 | 18.0-20.0 | 11.0-14.0 | 2.00-3.00 | 1.0-2.5 | 0.30-0.65 | 0.03 | 0.03 | - | 0.75 | - |
| 316L | S31683 | 0.03 | 18.0-20.0 | 11.0-14.0 | 2.00-3.00 | 1.0-2.5 | 0.30-0.65 | 0.03 | 0.03 | - | 0.75 | - |
| 317 | S31780 | 0.08 | 18.5-20.5 | 13.0-15.0 | 3.00-4.00 | 1.0-2.5 | 0.30-0.65 | 0.03 | 0.03 | - | 0.75 | - |
| 317L | S31783 | 0.03 | 18.5-20.5 | 13.0-15.0 | 3.00-4.00 | 1.0-2.5 | 0.30-0.65 | 0.03 | 0.03 | - | 0.75 | - |
| 318 | S31980 | 0.08 | 18.0-20.0 | 11.0-14.0 | 2.00-3.00 | 1.0-2.5 | 0.30-0.65 | 0.03 | 0.03 | - | 0.75 | ⁽³⁾ |
| 330 | N08331 | 0.18-0.25 | 15.0-17.0 | 34.0-37.0 | 0.75 | 1.0-2.5 | 0.30-0.65 | 0.03 | 0.03 | - | 0.75 | - |
| 347 | S34780 | 0.08 | 19.0-21.5 | 9.0-11.0 | 0.75 | 1.0-2.5 | 0.30-0.65 | 0.03 | 0.03 | - | 0.75 | - |
| Welding Electrodes and Rods for Ferritic-Austenitic Stainless Steels | | | | | | | | | | | | |
| 2209 | S39209 | 0.03 | 21.5-23.5 | 7.5-9.5 | 2.50-3.20 | 0.5-2.0 | 0.90 | 0.03 | 0.03 | 0.08-0.20 | 0.75 | - |

| Type | UNS | Chemical Composition, wt. % ⁽¹⁾⁽⁴⁾ | | | | | | | | | | |
|------|--------|---|-----------|---------|-----------|-----|-------------------|------|------|-----------|---------|-------|
| | | C | Cr | Ni | Mo | Mn | Si ⁽²⁾ | P | S | N | Cu | Other |
| 2307 | S32371 | 0.03 | 22.5-25.5 | 6.5-9.5 | 0.80 | 2.5 | 1.00 | 0.03 | 0.02 | 0.10-0.20 | 0.50 | - |
| 2553 | S39553 | 0.04 | 24.0-27.0 | 4.5-6.5 | 2.90-3.90 | 1.5 | 1.00 | 0.04 | 0.03 | 0.10-0.25 | 1.5-2.5 | - |
| 2594 | S32750 | 0.03 | 24.0-27.0 | 4.5-6.5 | 2.90-3.90 | 1.5 | 1.00 | 0.04 | 0.03 | 0.10-0.25 | 1.5-2.5 | - |

Notes:

- 1 Maximum, if range or minimum is not indicated.
- 2 For special applications, Silicon content can be less than the specified lower bound.
- 3 Nb may be reported as Nb + Ta.
- 4 Chemical composition requirements are to refer to AWS A5.4, A5.9 and A5.22.

TABLE 2
Mechanical Property Requirements⁽¹⁾

| Type | UNS | Tensile Strength, MPa (ksi), Min | Elongation, %, Min | | |
|--|--------|--|--|---------------------------|--|
| | | | AWS 5.4 Shield Metal Arc Welding Electrode | AWS 5.9 Bare Electrode | AWS 5.22 Flux Cored and Metal Cored Welding Electrode |
| Welding Electrodes and Rods for Austenitic Stainless Steels | | | | | |
| 308 | S30880 | 550 (80) | 30 | 35 | 30 |
| 308L | S30883 | 520 (75) | 30 | 35 | 30 |
| 308Mo | S30882 | 550 (80) | 30 | 35 | 30 |
| 309 | S30980 | 550 (80) | 30 | 30 | 30 |
| 309L | S30983 | 520 (75) | 30 | 30 | 30 |
| 309Mo | S30982 | 550 (80) | 30 | 30 | 25 |
| 309LMo | S30986 | 520 (75) | 30 | 30 | 25 |
| 310 | S31080 | 550 (80) | 30 | 30 | 30 |
| 312 | S31380 | 660 (95) | 22 | 22 | 22 |
| 316 | S31680 | 520 (75) | 30 | 30 | 30 |
| 316L | S31683 | 490 (70) | 30 | 30 | 30 |
| 317 | S31780 | 550 (80) | 30 | 30 | - |
| 317L | S31783 | 520 (75) | 30 | 30 | 20 |
| 318 | S31980 | 550 (80) | 25 | 25 | - |
| 330 | N08331 | 520 (75) | 25 | 25 | - |
| 347 | S34780 | 520 (75) | 30 | 30 | 30 |
| Welding Electrodes and Rods for Ferritic-Austenitic Stainless Steels | | | | | |

| <i>Type</i> | <i>UNS</i> | <i>Tensile Strength, MPa (ksi), Min</i> | <i>Elongation, %, Min</i> | | |
|-------------|------------|---|---|-----------------------------------|--|
| | | | <i>AWS 5.4 Shield Metal Arc Welding Electrode</i> | <i>AWS 5.9 Bare Electrode</i> | <i>AWS 5.22 Flux Cored and Metal Cored Welding Electrode</i> |
| 2209 | S39209 | 690 (100) | 20 | 20 | 20 |
| 2307 | S82371 | 690 (100) | 20 | 20 | 20 |
| 2553 | S39553 | 760 (110) | 15 | 15 | 15 |
| 2594 | S32750 | 760 (110) | 15 | 15 | 15 |

Note:

- 1 Mechanical property requirements are to be referred to AWS A5.4, A5.9 and A5.22 or other recognized standard.

CONTENTS

| | | |
|------------------|--|------------|
| SECTION 1 | Welding Procedure Qualification..... | 110 |
| 1 | Scope..... | 110 |
| 2 | Reference Documents..... | 110 |
| 3 | General..... | 110 |
| 4 | Welding Procedure Specification – pWPS and WPS..... | 111 |
| 4.1 | Preliminary Welding Procedure Specification (pWPS)..... | 111 |
| 4.2 | Welding Procedure Specification (WPS)..... | 111 |
| 5 | Welding Procedure Qualification Test – WPQT..... | 111 |
| 5.1 | General..... | 111 |
| 5.2 | Butt Welds..... | 112 |
| 5.3 | Fillet Welds..... | 114 |
| 5.4 | Re-testing..... | 116 |
| 5.5 | Test Record..... | 116 |
| 5.6 | Range of Approval..... | 116 |
| | TABLE 1 Examinations and Tests for Butt Welds for Welding Procedure Qualification..... | 112 |
| | TABLE 2 Specimen Size and Acceptable Minimum Average CVN Values..... | 113 |
| | TABLE 3 Examinations and Tests for Fillet Welds for Welding Procedure Qualification..... | 115 |
| SECTION 2 | Welding Operator and Welder Qualification..... | 117 |
| 1 | General..... | 117 |
| 2 | Reference Documents..... | 117 |
| 3 | Welding Operators Qualification..... | 118 |
| 4 | Welder Qualification..... | 118 |
| 4.1 | Previous Qualification Records..... | 118 |
| 4.2 | Performance Qualification by WPS Qualification..... | 119 |
| 4.3 | Examination and Test for Performance Qualification Record..... | 119 |
| 5 | Retest..... | 120 |

| | | |
|------------------|--|------------|
| 6 | Range of Qualification | 120 |
| 7 | Certification..... | 121 |
| 7.1 | Certification Process..... | 121 |
| 7.2 | Period of Validity of Initial Approval..... | 121 |
| 7.3 | Maintenance of the Approval..... | 122 |
| SECTION 3 | Production Welding and Fabrication..... | 123 |
| 1 | General..... | 123 |
| 1.1 | Scope..... | 123 |
| 1.2 | Responsibility..... | 123 |
| 1.3 | Plans and Specifications..... | 123 |
| 1.4 | Workmanship and Supervision..... | 124 |
| 1.5 | Welding Procedures and Welders..... | 124 |
| 1.6 | Environmental Conditions..... | 124 |
| 1.7 | Base Metals..... | 124 |
| 1.8 | Welding Filler Metals and Fluxes..... | 124 |
| 1.9 | Welding Characteristics..... | 124 |
| 2 | Reference Documents..... | 125 |
| 3 | Preparation for Welding..... | 125 |
| 3.1 | Edge Preparation and Fitting..... | 125 |
| 3.2 | Alignment..... | 125 |
| 3.3 | Mill Induced Discontinuities..... | 126 |
| 3.4 | Beam Copes and Weld Access Holes..... | 126 |
| 3.5 | Surface Preparation..... | 126 |
| 4 | Production Welding..... | 126 |
| 4.1 | Design..... | 126 |
| 4.2 | Distortion Control..... | 126 |
| 4.3 | Distortion of Members..... | 127 |
| 4.4 | Groove Weld Backing..... | 127 |
| 4.5 | Tack and Temporary Welds..... | 127 |
| 4.6 | Peening..... | 127 |
| 4.7 | Weld Profiling..... | 128 |
| 4.8 | Weld Termination | 128 |
| 4.9 | Back Gouging..... | 128 |
| 4.10 | Weld Cleaning..... | 128 |
| 5 | Butt Welds..... | 128 |
| 5.1 | Manual Welding Using Covered Electrodes..... | 128 |
| 5.2 | Submerged-arc Welding..... | 129 |
| 5.3 | Gas Metal-arc and Flux Cored-arc Welding | 129 |
| 5.4 | Gas Tungsten Arc Welding (GTAW)..... | 129 |
| 5.5 | Special Welding Processes and Techniques | 129 |

| | | | |
|-----------------|----------|---|------------|
| SECTION | 4 | Fabrication Verification and Nondestructive Testing of Production Welds..... | 130 |
| | 1 | General..... | 130 |
| | 2 | Reference Documents..... | 130 |
| | 3 | Fabrication Verification..... | 131 |
| | 3.1 | Verification of Materials | 131 |
| | 3.2 | Verification of WPS, PQR and Welder Qualification..... | 131 |
| | 3.3 | Verification of Work and Records..... | 131 |
| | 4 | Nondestructive Testing Practice of Production Welds..... | 132 |
| | 4.1 | Nondestructive Testing Practice for Structural Welds.... | 132 |
| | 4.2 | Nondestructive Testing for Pressure Vessels..... | 134 |
| | 5 | Nondestructive Testing..... | 134 |
| | 5.1 | General..... | 134 |
| | 5.2 | Visual Testing..... | 134 |
| | 5.3 | Liquid Penetrant Testing..... | 134 |
| | 5.4 | Radiographic Testing | 137 |
| | 5.5 | Ultrasonic Testing..... | 137 |
| | TABLE 1 | Weld Classification..... | 132 |
| | TABLE 2 | Nondestructive Testing/Examination Methods for Structure Welds ⁽¹⁾ | 132 |
| | TABLE 3 | Visual Testing Acceptance Criteria for Austenitic Stainless Steels..... | 135 |
| | TABLE 4 | Visual Testing Acceptance Criteria for Non-austenitic Stainless Steels..... | 136 |
| | TABLE 5 | Recommended Undercut Criteria for Non-austenitic Stainless Steels..... | 137 |
| | TABLE 6 | Acceptable/Unacceptable Ultrasonic Testing Results for Austenitic Stainless Steels under Static and Cyclic Loading ^(1,2) | 144 |
| | FIGURE 1 | Standard Reference Reflector..... | 140 |
| | FIGURE 2 | Recommended Calibration Block..... | 140 |
| | FIGURE 3 | Compression Wave Depth Calibration..... | 141 |
| | FIGURE 4 | Compression Wave Sensitivity Calibration..... | 141 |
| | FIGURE 5 | Shear Wave Distance and Sensitivity Calibration..... | 142 |
| | FIGURE 6 | Plan View of UT Scanning Patterns..... | 143 |
| | FIGURE 7 | Screen Marking..... | 144 |
| APPENDIX | 1 | Guidance for Handling and Storage of Stainless Steels..... | 146 |
| | 1 | Scope..... | 146 |
| | 2 | Storage..... | 146 |
| | 3 | Transportation..... | 146 |
| | 4 | Cutting..... | 147 |
| | 5 | Welding Setup | 147 |

| | | |
|----|---------------------------|-----|
| 6 | Forming and Bending | 148 |
| 7 | Fabrication..... | 148 |
| | 7.1 Environment..... | 148 |
| | 7.2 Assembly..... | 148 |
| | 7.3 Welding..... | 148 |
| 8 | Grinding..... | 149 |
| 9 | Segmentation..... | 149 |
| 10 | Peening and Painting..... | 149 |
| 11 | Embarkation..... | 149 |
| 12 | Outfitting..... | 150 |

CHAPTER 4 Welding of Stainless Steels

SECTION 1 Welding Procedure Qualification

1 Scope

In general, welding procedures are to be qualified to Appendix 2-A9 of the *ABS Rules for Materials and Welding (Part 2)* or to equivalent recognized standards such as AWS, EN, ISO, ASME, MIL and JIS.

Welding procedure qualification is also referred to Sections 2-4-1, 2-4-3, and 2-4-4 of the *ABS Rules for Materials and Welding (Part 2)*.

The specific requirements for welding procedure approval for austenitic and ferritic-austenitic (duplex) stainless steels are defined in this Section.

For welding procedure qualification of stainless steels in Liquefied Gases application, reference is to be made to 5C-8-6/5 of the *Marine Vessel Rules*.

Note:

The welding procedure qualification may be requested for ferritic, martensitic and precipitation hardened stainless steels. The welding procedure qualification tests are to be in accordance with the applicable recognized industry standards and submitted to ABS for review.

2 Reference Documents

ASME BPVC IX: Welding, Brazing, and Fusing Qualifications

ASTM E562: Standard Test Method for Determining Volume Fraction by Systematic Manual Point Count

ASTM G48: Standard Test Methods for Pitting and Crevice Corrosion Resistance of Stainless Steels and Related Alloys by Use of Ferric Chloride Solution

AWS D1.6: Structural Welding Code-Stainless Steel

ISO 14732: Qualification Testing of Welding Operators and Weld Setters for Mechanized and Automatic Welding of Metallic Materials

3 General

Welding procedures and qualification records are to be submitted to ABS for review.

Welding procedure qualification tests are intended to verify that a manufacturer is adequately qualified to perform welding operations using a particular procedure, and to demonstrate acceptable welding quality and that the required properties can be achieved.

In general, welding procedure tests are to reflect fabrication conditions with respect to welding equipment, inside or outside fabrication, weld preparation, etc. It is the manufacturer's responsibility to establish and document whether a procedure is suitable for the particular application.

For welding procedure approval, welding procedure qualification tests are to be carried out with satisfactory results. Welding procedure specifications (WPS) are to refer to the weld procedure qualification test (WPQT) results achieved during procedure qualification. The welding procedure qualification tests are documented in the procedure qualification record (PQR). PQR should contain the actual variables used to weld a test specimen, the destructive and nondestructive testing results, and the Surveyor's endorsement.

The approved WPS shall be restricted to the contractor or subcontractor performing the qualification. If the approved WPSs are to be applied at workshops or yards belonging to the contractor or subcontractor, they are to be under the same technical management working to the same quality assurance procedures and program.

Notes:

- 1 Welding transition joints between stainless steel and carbon steel will require suitable techniques, procedures, and welder skill to produce satisfactory joints that are suitable for the services. This may require application of buttering layers with higher alloy stainless steel consumables to the carbon steel weld prep side.
- 2 Other dissimilar welded joints may also require special techniques and buttering layers.

4 Welding Procedure Specification – pWPS and WPS

4.1 Preliminary Welding Procedure Specification (pWPS)

The shipyard or fabricator is to submit a pWPS for review prior to the WPQT. The pWPS can be modified and amended during the WPQT as necessary. The pWPS is to define all the variables (refer to AWS D1.6-Structural Welding Code-Stainless Steel or other recognized standards) that will be included in the WPS. In case the test pieces welded according to the pWPS show unacceptable results, the pWPS is to be adjusted by the shipyard or fabricator. The new pWPS is to be prepared and the test pieces welded in accordance with the new pWPS.

4.2 Welding Procedure Specification (WPS)

Upon completion of the WPQT and satisfactory review, the pWPS is given approval and becomes the WPS. The WPS is to be used as a basis for production welds. The approval range of the WPS is determined by the applicable code in conjunction with the test parameters and the qualification range of 4-1/6.

Note:

The generic term WPS is sometimes applied to a document before and after qualification tests, this can be accepted. The use of pWPS helps identify that the document has not yet been qualified by satisfactory tests.

5 Welding Procedure Qualification Test – WPQT

5.1 General

The general requirements for WPQT defined in 2-A9/4.1 of the *ABS Rules for Materials and Welding (Part 2)* can be applied.

5.2 Butt Welds

Unless otherwise agreed or required, 4-1/5.2 is to be followed for the butt welds WPQT.

5.2.1 Assembly of Test Pieces

The method of assembly of test pieces as defined in 2-A9/4.2.1 and 2-A9-1/Figure 1 of the *ABS Rules for Materials and Welding (Part 2)* are to be applied.

5.2.2 Examinations and Tests

The requirements for WPS tests are defined in 2-A9-1/Figure 2 of the *ABS Rules for Materials and Welding (Part 2)*. The specific requirements for examinations and tests for stainless steel butt welds are defined in 4-1/5.2.2 of this document.

TABLE 1
Examinations and Tests for Butt Welds for Welding Procedure Qualification

| | |
|------------------------------------|---|
| Visual testing | 100% |
| Surface crack detection | 100% (dye penetrant testing) |
| Radiographic or Ultrasonic testing | 100% (refer to AWS D1.6/6 Part B and C) |
| Transverse tensile test | Two specimens as per 4-1/5.2.2(b) |
| Transverse bend test | Four specimens as per 4-1/5.2.2(d) |
| Charpy V-notch impact test | As per 4-1/5.2.2(e) |
| Macro and micro examination | One specimen as per 4-1/5.2.2(f) |
| Hardness test | As per 4-1/5.2.2(g), if applicable |
| Corrosion test | As per 4-1/5.2.2(h), if required |

5.2.2(a) Nondestructive Testing. Test assemblies are to be examined by visual and by nondestructive testing prior to the cutting of test specimens. NDT procedures and results are to be to the satisfaction of the Surveyor in accordance with the *ABS Guide for Nondestructive Inspection*.

Imperfections detected by visual or nondestructive testing are to be assessed in accordance with ISO 5817, class B, except for excess weld metal and excess penetration for which level C applies. Other quality standards may be applied subject to ABS agreement.

5.2.2(b) Transverse Tensile Test. Testing is to be carried out in accordance with 2-4-3/Figure 3 of the *ABS Rules for Materials and Welding (Part 2)*. The tensile strength recorded for each specimen is not to be less than the minimum required value for the base metal. When butt welds are made between plates of different grades, the tensile strength to be obtained on the welded assembly is to be in accordance with the requirements relating to the steel grade having lower strength. If a lower strength consumable is proposed, the details are to be submitted to ABS for consideration.

5.2.2(c) Bend Test. The requirements for WPQT transverse bend tests are to be in accordance with 2-4-3/Figure 5 and 2-4-3/Figure 6 and 2-A9/7.3.2(d) of the *ABS Rules for Materials and Welding (Part 2)*.

The mandrel diameter is to be four times the thickness and the bending angle is to be 180°. After testing, the test specimens are not to reveal any open defects in any direction greater than 3 mm

(0.015 in.). Defects appearing at the corners of a test specimen during testing are to be investigated on a case-by-case basis.

Two root and two face bend specimens are to be tested. For thickness 12.5 mm (0.5 in.) and over, four side bend specimens may alternatively be tested.

5.2.2(d) *Impact Test.* The requirements for WPQT impact testing and retesting defined in 2-A9/7.3.2(e) of the *ABS Rules for Materials and Welding (Part 2)* are to be applied.

- i) CVN is to be tested at the requested test temperature, generally, -20°C (-4°F) or 5°C (41°F) below the design temperature, whichever is lower.
- ii) For austenitic stainless steels, CVN is to be tested at -196°C (-320°F) for the application with design temperature lower than -105°C (-157°F) for LT designation.

Standard CVN samples are to be 10 mm \times 10 mm (0.40 inch \times 0.40 inch) where the material thickness permits. Reduced CVN samples can be used in the case that the material thickness is insufficient for the standard size. The largest practicable CVN sample associated with the weld thickness is to be taken and the acceptable minimum average CVN values are as follows:

TABLE 2
Specimen Size and Acceptable Minimum Average CVN Values

| <i>Specimen Size</i> | <i>CVN J (ft-lbf), Average</i> | <i>CVN J (ft-lbf), Single</i> |
|--|--------------------------------|-------------------------------|
| 10 mm \times 10 mm (0.40 inch \times 0.40 inch) | 27 (20) | 19 (14) |
| 10 mm \times 7.5 mm (0.40 inch \times 0.30 inch) | 23 (17) | 17 (13) |
| 10 mm \times 5.0 mm (0.40 inch \times 0.20 inch) | 18 (13) | 13 (10) |
| 10 mm \times 2.5 mm (0.40 inch \times 0.10 inch) ⁽¹⁾ | 14 (10) | 10 (8) |

Note:

- 1 This size Charpy sample is to be agreed by ABS.

For dissimilar materials butt welded, both sides of the HAZ are to have CVN tests performed.

5.2.2(e) *Macro and Micro Examination.* Test specimens are to be prepared and etched on one side to clearly reveal the weld metal, fusion line, and heat affected zone.

Macro examination (at $\times 5$ magnification for reference) is to include approximately 10 mm (0.40 in.) of unaffected base metal or full thickness of base metal, whichever is less.

The examination is to reveal a regular weld profile, fusion between adjacent layers of weld and weld to base metal and the absence of defects such as cracks, and lack of fusion.

For duplex stainless steels, micrographic examination at $\times 500$ magnification is to be taken in the weld metal, HAZ and base metal along the weld root and cap. The microstructure is to be appropriately etched, examined and free from carbide and precipitate at grain boundaries. The ferrite percentage is to be determined in accordance with ASTM E562 or equivalent standard. The ferrite percentage is to be between 30% to 70%.

HAZ is to be free from detrimental inter-metallic phases and grain boundary precipitates.

5.2.2(f) *Hardness Test*

- i) For austenitic stainless steels, hardness testing is not required.
- ii) Hardness tests are required for duplex stainless steels. The Vickers method HV 5 or HV 10 is normally used. The indentations are to be made in the weld metal, the HAZ and the base metal. The hardness values are to be measured and recorded. At least two rows of indentations are to be carried out, refer to the example in 2-A9-A2/Figures 1 and 2 of the *ABS Rules for Materials and Welding (Part 2)*. For each row of indentations, the minimum of 3 individual indentations in the weld metal, the HAZ (both sides) and the base metal (both sides) are to be tested. Hardness values in HAZ are not to exceed the maximum hardness specified for base metal. Hardness values in weld metal are not to exceed the maximum hardness specified for the applied welding consumables. Unless otherwise required, the maximum hardness is 300 HV10/30 HRc for 2205 and 330 HV10/32 HRc for 2507.

5.2.2(g) *Corrosion Test*. For duplex stainless steel weldment, inter-granular corrosion testing is to be performed in the HAZ in accordance with ASTM G48 or equivalent for pitting corrosion. Unless otherwise specified, corrosion testing is not required when duplex stainless steel is to be welded with other type of stainless steel, carbon steel, low alloy steel.

- i) The test specimen is to be taken in as-welded condition after weld cleaning. Cut edges shall be prepared according to ASTM G48.
- ii) The test specimens are required to be full thickness. If grinding is performed, the surface is to be smooth without notches and the full thickness of base metal is to be maintained. At least 25 mm (1 in.) along the weld and 50 mm (2 in.) across the weld are to be included.
- iii) The whole specimen shall be pickled then weighed and tested. Pickling may be performed for 5 min. at 60°C (140°F) in a solution of 20% nitric acid + 5% hydrofluoric acid + water.
- iv) For 2205 duplex, the test specimens are to be exposed to a ferric chloride solution for 24 hours at 20°C (68°F). Mass loss is to be reported.
- v) For 2507 duplex, the test specimens are to be exposed to a ferric chloride solution for 24 hours at 50°C (122°F). Mass loss is to be reported;
- vi) No visible pitting is allowed on the specimen surface at ×20 magnification, and the general mass loss is to be less than 4 g/m².

5.3 Fillet Welds

Unless otherwise agreed or required, 4-1/5.3 is to be followed for the fillet welds WPQT.

5.3.1 Assembly of Test Pieces

The assembly of test pieces defined in 2-A9-1/Figure 3 and 2-A9-1/7.5.1 of the *ABS Rules for Materials and Welding (Part 2)* is to be applied.

5.3.2 Welding of Test Pieces

The test assembly is welded on one side only. For single run manual and semi-automatic welding, a stop and start is to be included in the test length and its position is to be clearly marked for subsequent examination.

5.3.3 Examinations and Tests

The requirements for WPQT examinations and tests defined in 2-A9-A2/Figure 3, 2-A9-A2/Figure 4A and 2-A9-A2/4B of the *ABS Rules for Materials and Welding (Part 2)* are to be applied. The specific requirements for examinations and tests for stainless steel fillet welds are to be defined in 4-1/5.3.2 of this document.

**TABLE 3
 Examinations and Tests for Fillet Welds for Welding Procedure Qualification**

| | |
|-----------------------------|---|
| Visual testing | 100% |
| Surface crack detection | 100% (dye penetrant testing) |
| Macro and micro examination | One specimen as per 2-A9-1/7.5.3(b) of the <i>ABS Rules for Materials and Welding (Part 2)</i> |
| Hardness test | As per 2-A9-1/7.5.3(c) of the <i>ABS Rules for Materials and Welding (Part 2)</i> , if applicable |
| Fracture test | As per 2-A9-1/7.5.3(d) of the <i>ABS Rules for Materials and Welding (Part 2)</i> |
| Corrosion test | Not applicable for fillet welds |

5.3.3(a) Nondestructive Testing. 2-A9-1/7.5.3(a) of the *ABS Rules for Materials and Welding (Part 2)* is to be referred to for the nondestructive testing for fillet welds. NDT procedures and results are to be to the satisfaction of the Surveyor in accordance with the *ABS Guide for Nondestructive Inspection*. Delayed inspection is not required.

5.3.3(b) Macro and Micro Examination. 2-A9-1/7.5.3(b) of the *ABS Rules for Materials and Welding (Part 2)* is to be referred for the macro and micro examination for fillet welds.

Test specimens are to be prepared and etched on one side to clearly reveal the weld metal, fusion line, and heat affected zone.

Macro examination is to include approximately 10 mm (0.40 in.) of unaffected base metal or full thickness of base metal, whichever is less.

The examination is to reveal a regular weld profile, fusion between adjacent layers of weld, stop and start regions, weld to base metal and the absence of defects such as cracks or lack of fusion.

For duplex stainless steels, micro graphic examination at ×500 magnification is to be taken in the weld metal, HAZ and base metal along the weld root and cap. The microstructure is to be appropriately etched, examined and free from carbide and precipitate at grain boundaries. The ferrite percentage is to be determined in accordance with ASTM E562 or equivalent standard. The ferrite percentage is to be between 30% to 70%.

5.3.3(c) Hardness Test. 2-A9-1/7.5.3(c) of the *ABS Rules for Materials and Welding (Part 2)* is to be referred for the hardness test of fillet welds.

- i)* For austenitic stainless steels, hardness testing is not required.
- ii)* Hardness tests are required for duplex stainless steels. The Vickers method HV 5 or HV 10 is normally used. The indentations are to be made in the weld metal, the HAZ and the base metal. The hardness values are to be measured and recorded. At least two rows of indentations are to be carried out, refer to the example in 2-A9-A2/Figure 1 and 2-A9-A2/Figure 2 of the *ABS Rules for Materials and Welding (Part 2)*. For each row of indentations, the minimum of 3 individual indentations in the weld metal, the HAZ (both

sides) and the base metal (both sides) are to be tested. Hardness values in HAZ are not to exceed the maximum hardness specified for base metal. Hardness values in weld metal are not to exceed the maximum hardness specified for the applied welding consumables. Unless otherwise required, the maximum hardness is 300 HV10/30 HRc for 2205 and 330 HV10/32 HRc for 2507.

5.3.3(d) *Fracture Test*. The fracture test is to be carried out by folding the upright plate onto the through plate.

Evaluation is to concentrate on cracks, porosity and pores, inclusions, lack of fusion and incomplete penetration. Imperfections that are detected are to be assessed in accordance with ISO 5817, class B.

5.4 Re-testing

The requirements for re-testing defined in 2-A9/7.7 of the *ABS Rules for Materials and Welding (Part 2)* are to be applied.

5.5 Test Record

The requirements for test record defined in 2-A9/7.9 of the *ABS Rules for Materials and Welding (Part 2)* are to be applied.

5.6 Range of Approval

The requirements for range of approval defined in 2-A9/9 of the *ABS Rules for Materials and Welding (Part 2)* are to be applied. A new qualification is to be carried out and submitted to ABS for review in the case of any of the following:

- i) Heat input variation greater than $\pm 15\%$ qualified procedure
- ii) Any change in other essential variables, such as base metals, filler metal, positions, groove welds, or shielding gas
- iii) Any quality concern by the ABS Surveyor

CHAPTER 4 Welding of Stainless Steels

SECTION 2 Welding Operator and Welder Qualification

1 General

The general guidelines and requirements of Appendix 2-A10 and Section 2-4-3 of the *ABS Rules for Materials and Welding (Part 2)* are to be applied for welding operator and welder qualification.

The requirements are also referred to the following sections, if applicable.

- Section 2-4-1 of the *ABS Rules for Materials and Welding (Part 2)* for hull structure and structural welding
- Section 2-4-2 of the *ABS Rules for Materials and Welding (Part 2)* for boilers, unfired pressure vessels, piping and engineering structures
- Section 2-4-4 of the *ABS Rules for Materials and Welding (Part 2)* for piping

In addition, the specific requirements for welding operator and welder qualification for austenitic and ferritic-austenitic (duplex) stainless steels are defined in this document.

Other welder or operator qualification standards for stainless steels can be applied such as ISO 9606-1, ISO 14732, AWS D1.6, ASME IX or equivalent subject to the agreement with ABS.

The training of welders and welding operators, control of their qualification, and maintenance of their skills are the responsibility of the builders and subcontractors. When requested, documents of training and qualification control are to be submitted to ABS. The ABS surveyor may request demonstration of a welder's capability.

Records of certified welders and welding operators are to be maintained by builders and subcontractors together with dated qualification test documents and welders' training. The qualification documents are to include the information about the base metal, type of welding consumable, welding process, type of welded joint, material thickness, welding position, as well as destructive and nondestructive test results.

At the discretion of ABS, qualification of welding operators and welders certified to other recognized industry standards by other organizations may be accepted for vessels in operation or for offshore field modifications or repairs, provided full compliance to the applicable standard is maintained.

2 Reference Documents

ASME BPVC IX : Welding, Brazing, and Fusing Qualifications

ASTM E562: Standard Test Method for Determining Volume Fraction by Systematic Manual Point Count

ASTM G48: Standard Test Methods for Pitting and Crevice Corrosion Resistance of Stainless Steels and Related Alloys by Use of Ferric Chloride Solution

AWS D1.6: Structural Welding Code-Stainless Steel

ISO 3834-2: Comprehensive Quality Requirements for Fusion Welding of Metallic Materials

ISO 3834-3: Standard Quality Requirements for Fusion Welding of Metallic Materials

ISO 5817: Fusion-Welded Joints in Steel, Nickel, Titanium and Their Alloys (Beam Welding Excluded)-Quality Levels for Imperfections

ISO 14732: Qualification Testing of Welding Operators and Weld Setters for Mechanized and Automatic Welding of Metallic Materials

3 Welding Operators Qualification

The welding operator responsible for setting up and/or adjusting fully mechanized and automatic equipment, such as SAW, gravity welding (auto SMAW) or MAG welding with auto-carriage must be qualified.

Qualification tests and approval range for the welding operator are to be in accordance with the rule or standard applied. The records for a welding operator are to include evidence of adequate regular training, to set up, program, and operate welding equipment in accordance with the applicable WPS (welding procedure specification).

In addition to the above requirements, welding operators and welders need the following training and skills:

- i)* Groove dimension
- ii)* Groove cleanliness
- iii)* Protecting against weather and wind
- iv)* Weld stop, start and terminations
- v)* Weld repair
- vi)* Storing and handling of welding consumables
- vii)* General maintenance of equipment

Appropriate records are to be maintained by the shipbuilder, manufacturer, or subcontractor and are to be provided at the Surveyor's request. At the discretion of ABS, the alternative welding operator certificate may be accepted, per the applicable standards such as ISO 14732, AWS D1.6, ASME IX or equivalent standards.

4 Welder Qualification

The general guidelines and requirements are defined in 4-2/1. Welder qualification is intended for welder performance qualification applied specific WPS.

4.1 Previous Qualification Records

At the discretion of ABS, the previous qualification of welders with properly documented evidence may be accepted, provided the additional requirements in this document are met.

4.2 Performance Qualification by WPS Qualification

The welder who performs the welding in the WPS qualification is to obtain performance qualification for the approval range associated with the WPS.

4.3 Examination and Test for Performance Qualification Record

4.3.1 General

The welder qualification tests are to determine the welder's ability to produce sound welds with a specific welding process.

The general requirements defined for test assembly, examination and testing in Section 2-4-3 of *ABS Rules for Materials and Welding (Part 2)* or an alternative accepted standard are to be applied.

Testing is to be witnessed by the Surveyor. The test assemblies are to be examined and tested as follows:

i) For butt welds:

- Visual examination
- Bend test

Note:

Radiographic test or fracture test may be carried out in lieu of bend test, except for gas-shielded welding processes with solid wire or metal cored wire.

ii) For fillet welds:

- Visual examination
- Fracture test

Note: Two macro sections may be taken in lieu of the fracture test.

iii) For tack welds:

- For stainless steel welding, tack welds are to be performed by fully qualified welders.

4.3.2 Visual Testing

Welds are to be visually examined prior to the cutting of the test specimen for the bend test and fracture test. The result of the examination is to show the absence of cracks or other serious imperfections.

Imperfections detected are to be assessed in accordance with ISO 5817 quality level B, except for the following imperfection types for which level C applies:

i) Excess weld metal

ii) Excess penetration

iii) Excessive convexity

iv) Excessive throat thickness

4.3.3 Guided-Bend Test

Guided-bend test samples are to be bent 180° at the mandrel with the diameter 4 times the sample thickness. After the bending test, the surface should not contain discontinuities exceeding the following dimensions.

i) 3 mm (1/8 in.) measured in any direction on the surface

- ii) 10 mm (3/8 in.) – The sum of the greatest dimensions of all discontinuities exceeding 1 mm (1/32 in.), but less than or equal to 3 mm (1/8 in.)
- iii) 6 mm (1/4 in.) – The maximum corner crack, except when the corner crack resulted from visible slag inclusion or other fusion type discontinuities, then the 3 mm (1/8 in.) maximum shall apply

At the discretion of ABS, radiographic testing of the test weld may be used in lieu of mechanical testing with the exception of joints welded by GMAW-S. (GMAW-S must be bend tested.)

4.3.4 Radiography Testing

If radiography is used in lieu of the bend test, the weld reinforcement need not be ground or otherwise smoothed for inspection unless its surface irregularities with the base metal would cause objectionable weld discontinuities to be obscured in the radiograph. If the backing is removed for radiographic testing, the root shall be ground flush with the base metal. A 25 mm (1 in.) length at each end of the test plate is to be excluded from evaluation. When radiographic testing is used, imperfections detected are to be assessed in accordance with ISO 5817, level B for structural welds or the applicable standard. For pressure vessel and pipe welder qualification, the acceptance criteria for radiography is to follow the standard applied.

4.3.5 Fracture Test

When a fracture test is used for fillet welds, the fracture test is to be performed by folding the upright plate onto the through plate. Evaluation is to concentrate on cracks, porosity and pores, inclusions, lack of fusion, and incomplete penetration. The detected imperfections are to be assessed in accordance with 2-4-3/Figure 8 of the *ABS Rules for Materials and Welding (Part 2)*, or other applicable standard such as ISO 5817, level B.

5 Retest

When a welder fails a qualification test, the following applies:

- i) In cases where the welder fails to meet the requirements in part of the tests, a retest may be welded immediately, consisting of another test assembly of each type of welded joint and position that the welder failed. In this case, the test is to be done for duplicate test specimens of each failed test.

All retest specimens are to meet all the specified requirements;
- ii) In cases where the welder fails to meet the requirements in all parts of the required tests or in the retest, the welder is to undertake further training and practice;
- iii) When there is specific reason to question the welder's ability or the period of effectiveness has lapsed, the welder is to be requalified.

Where any test specimen does not comply with dimensional specifications due to poor machining, a replacement test assembly is to be welded and tested.

6 Range of Qualification

In general, a welder is qualified in relation to the following variables.

- i) Base metal group, type, or thickness
- ii) Welding consumables such as F number, A number, and type of electrode
- iii) Welding process
- iv) Welding position
- v) Type of welded joint (single side, double sides, with or without backing and fillet weld)

Also refer to Appendix 2-A10 of ABS *Rules for Materials and Welding (Part 2)* or other applicable standard.

Note: Depending upon the standard applied, the essential variables for welder qualification might not include all the variables above.

7 Certification

7.1 Certification Process

At the discretion of ABS, a welder or operator certified by other classification society or independent organization can be evaluated and accepted on a case-by-case basis. ABS reserves the right to re-validate, which may include testing prior to production, additional NDT and/or welding production tests.

Welding and testing of a test assembly is to be witnessed by the Surveyor. At the client's request ABS will certify the welder after the welder passes the qualification tests. Each Shipyard, Manufacturer and Subcontractor is to be responsible for the control of the validity of the certificate and the range of the approval.

The following items are to be specified in the certificate.

- i) Range of qualification for base metal, welding processes, filler metal type, types of welded joint, plate thicknesses, and welding positions
- ii) Expiry date of the qualification
- iii) Name, identification, and the photograph of the welder
- iv) Name of shipbuilder, manufacturer, and subcontractor

When a certificate is issued, the related documents such as test reports and/or re-validation records are to be archived as annexes to the copy of the certificate. An example of welder qualification certificate is in Annex 2-A10-A1 of ABS *Rules for Materials and Welding (Part 2)*.

The status of approvals of each individual qualification is to be demonstrated to ABS when requested.

7.2 Period of Validity of Initial Approval

Normally, the validity of the welder's approval begins from the issue date of qualification certificate when all the required tests are satisfactorily completed.

The validity is to be confirmed at six-month intervals by the shipyards, manufacturers, or subcontractor personnel who are responsible for production weld quality, provided that all the following conditions are fulfilled to the satisfaction of Surveyor:

- i) The welder has been engaged with reasonable continuity on welding work containing the current range of approval without interruption longer than six months;
- ii) The welder's work is in general to be in accordance with the technical conditions under which the approval test was carried out;
- iii) There is to be no specific reason to question the welder's skill and knowledge.

If any of these conditions are not fulfilled, ABS is to be informed and the certificate is to be withdrawn.

The validity of the certificate may be maintained in agreement with ABS. The maintenance scheme of qualification is in accordance with 4-2/7.3i., 4-2/7.3ii., or 4-2/7.3iii..

7.3 Maintenance of the Approval

Revalidation is to be carried out by ABS. The skill of the welder is to be periodically verified by one of the following to the satisfaction of the attending Surveyor.

- i)* The welder is to be tested every three years;
- ii)* Every two years, two welds made during the last six months of the two years' validity period are to be tested by radiographic or ultrasonic testing or destructive testing and are to be recorded. The weld tested is to reproduce the initial test conditions except for the thickness. These tests revalidate the welder's qualifications for an additional two years;
- iii)* The manufacturer is to maintain the qualification and revalidation per the practice of AWS D1.1, or equivalent standards. The welder has been engaged with reasonable continuity on welding work containing the essential welding variables without interruption longer than six months.

The manufacturer's quality program is to be verified in accordance with ISO 3834-2, 3834-3 or equivalent requirement.

ABS or the builder, manufacturer, or subcontractor is to verify compliance with the above conditions and sign the maintenance of the welder's qualification certificate.

CHAPTER 4 Welding of Stainless Steels

SECTION 3 Production Welding and Fabrication

1 General

1.1 Scope

Production welding and fabrication is to be carried out in accordance with qualified welding procedure specifications, and performed by qualified welding operators or qualified welders. The weld details indicated in engineering drawings and specifications are to be followed.

Production welding and fabrication requirements are also defined in the *ABS Rules for Materials and Welding (Part 2)* as indicated below for reference:

- Section 2-4-1 for hull structure and structural welding
- Section 2-4-2 for boilers, unfired pressure vessels, piping and engineering structures
- Section 2-4-4 for piping

The specific requirements for production welds of stainless steels are to be defined in this Section or an equivalent standard, such as AWS D1.6.

Reference is to be made to 5C-8-6/5 of the *Marine Vessel Rules* for stainless steel weldments in Liquefied Gases application.

Note:

Production welding and fabrication may be proposed for ferritic, martensitic and precipitation hardened stainless steels. The practices are to be in accordance with the applicable recognized industry standards and submitted to ABS for review.

1.2 Responsibility

The shipyard and manufacturer are responsible for the quality of work and the items they produce. The quality of the work is to be evaluated prior to release to subsequent stages of processing or inspection.

1.3 Plans and Specifications

The plans submitted are to clearly indicate the proposed extent of welding to be used. The welding process, filler metal and joint design indicating full/partial penetration weld are to be shown on the detail drawings or in separate specifications submitted for approval which should distinguish between manual and

automatic welding. The shipbuilders or fabricators are to prepare and file with the Surveyor a planned procedure to be followed in fabrication, welding and welding sequence.

1.4 Workmanship and Supervision

The Surveyor is to be satisfied that all welders and welding operators to be employed in the construction of vessels and equipment to be classed, are properly qualified and are experienced in the work proposed. The Surveyor is also to be satisfied as to the employment of a sufficient number of skilled supervisors to supervise and control all welding operations. Inspection of welds employing methods outlined in Chapter 4, Section 4 is to be carried out to the satisfaction of the Surveyor.

1.5 Welding Procedures and Welders

Production welding and fabrication is to be performed using qualified welders, qualified welding procedure specifications and equipment installed and set up by qualified welding operators.

1.6 Environmental Conditions

Welding and fabrication are not to be carried out on wet surfaces or in high wind. The maximum interpass temperature is to be monitored in accordance with the qualified WPS.

Cross contamination is to be prevented. Welding and fabrication of stainless steel materials are to be in designated areas separated from other materials, such as carbon steels and copper alloys.

1.7 Base Metals

The shipyard and manufacturer are to review the base metal grade, composition, properties and inspection report. Base metals are to be consistent with best manufacturing and inspection practices. Base metal discontinuities or defects out of the tolerances are not acceptable.

1.8 Welding Filler Metals and Fluxes

The shipyard and manufacture are to verify the certification, and control the storage and handling of welding filler metals and fluxes in accordance with the consumables manufacturer's recommendations. Welding filler metals removed from the original packaging are to be protected per manufacturer's practice.

1.9 Welding Characteristics

There are three important factors for stainless steel weldability which can be improved using low-carbon grade filler materials.

- i)* Cracking tendency of weld metal or its microstructure at the fusion line
- ii)* Precipitation of chromium carbides, leading to potential intergranular corrosion;
- iii)* Formation of intermetallic sigma-phase within certain temperature ranges and chromium concentrations, which can possibly lead to embrittlement of the steel.

1.9.1 Austenitic

Compared with carbon steel, austenitic stainless steels have lower melting temperatures, higher electrical resistance, lower thermal conductivity and 50% higher coefficient of thermal expansion (CTE). Accordingly, fusion can be achieved with less heat input. The higher CTE may result in distortion, therefore, clamping, tack welding or other distortion control measures are required, refer to 4-3/4.2.

1.9.2 Duplex

Compared to austenitic stainless steels, the solidification structure of duplex weld metal is more resistant to hot cracking than austenitic weld metal. Duplex has higher thermal conductivity, lower CTE and lower local thermal stresses. The reduced heat input may result in excessively ferrite, loss of toughness, lower corrosion resistance in fusion metal and HAZ. Conversely, higher heat

input may increase the formation of the intermetallic phases. To avoid precipitation of intermetallic phases in weld metal and HAZ, rapid cooling may be required. Post weld heat treatment is not needed, it may be harmful and can cause a loss of fracture toughness and corrosion resistance.

Note:

Production welding and fabrication of ferritic, martensitic and precipitation hardened stainless steels may have different welding characteristics. The practices are to be in accordance with the applicable recognized industry standards and manufacturers' recommendations.

2 Reference Documents

ASME BPVC IX: Welding, Brazing, and Fusing Qualifications

AWS D1.6: Structural Welding Code-Stainless Steel

AWS B1.10: Guide for Nondestructive Inspection of Welds

ISO 3834-2: Quality requirements for fusion welding of metallic materials – Part 2: Comprehensive quality requirements

ISO 3834-3: Quality requirements for fusion welding of metallic materials – Part 3: Standard quality requirements

ISO 5817: Fusion-welded joints in steel, nickel, titanium and their alloys (beam welding excluded) – Quality levels for imperfections

ISO 14732: Qualification Testing of Welding Operators and Weld Setters for Mechanized and Automatic Welding of Metallic Materials

3 Preparation for Welding

The requirements for preparation for welding defined in Sections 2-4-1, 2-4-2, and 2-4-4 of the *ABS Rules for Materials and Welding (Part 2)* are to be applied. The specific requirements for preparation of stainless steel welding are defined as follows.

3.1 Edge Preparation and Fitting

Cutting equipment is to produce smooth cuts. Notches or gouges on cut surfaces are not to exceed 2 mm (1/16 in.) for materials less than 16 mm (5/8 in.) or 10% of the materials thickness for materials 16 mm (5/8 in.) or greater. Notches and gouges above these ranges are to be repaired.

Notches and gouges may be repaired by grinding or machining, provided the depth is less than 3 mm (1/8 in.) or 20% of the materials thickness. Repairs are to be blended to a smooth transition into the surrounding surfaces to a slope not exceeding 1 in 4. Notches or gouges above the range are to be repaired by excavation. Repaired surfaces shall be cleaned to bright metal after completing the repair.

Discontinuities other than notches or gouges observed during cutting are to be repaired. Excavation of defective areas is limited to a depth of $t/3$. Repair of defect excavations exceeding $t/3$ are to be submitted to ABS for prior to approval.

3.2 Alignment

Means are to be provided for holding the parts to be welded in correct position and alignment during the welding operation. In general, strong backs, or other appliances used for this purpose are to be so arranged as to allow for expansion and contraction during production welding. The removal of such items is to be carried out to the satisfaction of the Surveyor.

3.3 Mill Induced Discontinuities

If mill induced discontinuities on the surface of materials are observed, discontinuities are to be evaluated or repaired as specified in the applicable material specification.

Unacceptable surface defects found by visual or ultrasonic inspection may be removed by grinding, gouging or machining, provided that the remaining thickness is within materials thickness tolerance. After removal of defects, material is to be blended uniformly into the surrounding surface. If necessary, appropriate NDT may be specified for inspection.

Depending on the extent or type of discontinuities, the shipyard or manufacturer may request the supplier to replace the materials in question.

3.4 Beam Copes and Weld Access Holes

The fabricator is to have standard practices for beam copes and weld access holes.

In general:

- i) Beam copes and weld access holes are to have a smooth transition without notches or sharp corners.
- ii) The size and shape of access holes are to be sufficient for deposition of sound weld metal and provide the clearance for weld attachments such as backing and tabs.
- iii) All reentrant corners or cut materials should provide a gradual transition with a minimum radius of 25 mm (1 in.).

3.5 Surface Preparation

Grinding is to be done with an iron-free abrasive wheel. Brushing is to be done with stainless steel brushes. Grinding disks, saw blades, files, wire brushes or cutting tools that have been used for carbon steels are not to be used on stainless steels.

Groove profile dimensions are to be maintained as specified on the WPS.

Surface oxides are to be removed by mechanical methods, chemical cleaning or other means. Surfaces are to be clean and free from surface oxides, organic contaminants, paint and material discontinuities that could affect the quality of the weldments. Compliance with these cleanliness requirements is of prime importance in the welding of stainless steels.

4 Production Welding

The requirements for production welding defined in Sections 2-4-1, 2-4-2, and 2-4-4 of the *ABS Rules for Materials and Welding (Part 2)* are to be applied. The specific requirements for production of stainless steel welding are defined as follows.

4.1 Design

Weld preparation details are to be in accordance with a weld design code applicable to stainless steels. All connections are to be fabricated in accordance with the design drawings and specifications.

Weld design is to take into account the possibility of crevice corrosion between closely mating surfaces. Typically, fillet welds and partial penetration welds are to be continuous on both sides, and ends, of the joints.

4.2 Distortion Control

The shipyard and manufacturer should have appropriate fabrication methods and procedures to avoid excess distortion and shrinkage. This can include tack welds, planned sequence welding, strong backs and balanced applied heat during welding etc.

Shipyards and manufacturers are to prepare WPSs and use fabrication methods capable of producing the required welds. Where it is important and necessary to carefully control shrinkage stresses and distortion, joints or groups of joints are to be clearly identified on the applicable drawings and a welding sequence and distortion control plan may need to be prepared and qualified prior to the start of welding.

During welding, joints with significant shrinkage are to be welded before joints with less shrinkage.

Members to be welded are in correct alignment and held in position. The use of jigs and fixtures may be required. Allowances are to be made for warping and shrinkage.

4.3 Distortion of Members

At the discretion of ABS, members distorted by welding may be straightened by mechanical straightening. Close attention to control of heat during straightening is to be maintained. Heat straightening should not affect the corrosion resistance or sensitize the microstructure, and should not introduce excessive stress into the structure. Heat straightening temperature should not exceed 430°C (800°F) for austenitic stainless steels and 315°C (600°F) for duplex stainless steels.

4.4 Groove Weld Backing

In the case of groove weld backing, fused metal backing is to be at least the full length of the weld joint. Depending on the configuration, the backing may be required to exceed the length of the weld. Metal backing materials are to be the same base metal grade as qualified in the WPS. The weld metal is to be fused thoroughly with the backing to meet the quality requirements. The thicknesses of backing bars are to be sufficient to prevent melt through. All backing shall be removed unless the application and design permits the backing to remain in place.

Nonmetallic or non-fused metallic backing, if used, is to be completely removed when the welding is completed. If needed, the back side of the welds is to be properly prepared by grinding or other suitable means for visual or nondestructive testing (NDT).

4.5 Tack and Temporary Welds

Tack and temporary welds are to be completed by a qualified welder using a qualified welding filler according to a qualified welding procedure.

Tack welds should be done first at each end then in the middle of the span until the specified distance between tacks is met. The spacing between tacks for stainless plates should be considerably shorter than carbon steel due to the higher coefficient of thermal expansion of stainless steels. Tack welds should not crack and should keep the plate aligned.

The quality of tack and temporary welds should be the same quality as the final welds. Upon removal, temporary welds should be made flush with permanent materials. Unless otherwise specified, as a minimum, surfaces are to be examined by visual examination and base materials are not to be gouged, nicked or damaged.

Note:

Coefficient of thermal expansion of stainless steels is higher than carbon steel, accordingly, more tack welds are needed to fix the weld joint.

4.6 Peening

Peening is a cold working process in which metal materials or components are bombarded by tiny balls, such as stainless steels, which may improve the end use mechanical properties depending on impact angles, intensities, velocities, nozzle-diameters, peening time, type of materials and surface coverage etc.

If specified, peening may be used on intermediate weld layers to mechanically reduce and control the residual stress and distortion of stainless steels. Measures are to be taken to prevent overlapping folds or cracking of weld metal or base metal. Peening on root or cover passes of welds is generally prohibited.

Manual slag hammers, chisels, and light weight vibration tool to remove the slag and spatter are permitted but are not considered as peening.

4.7 Weld Profiling

To improve fatigue life, weld profiling may be carried out in critical areas. Welds may be profiled at weld toes using grinding, TIG (tungsten inert gas) dressing, or ultrasonic or laser peening to the satisfaction of the attending Surveyor. TIG dressing may need a qualified procedure and welder since the procedure and welding skills may affect the joint integrity.

4.8 Weld Termination

Welds shall terminate at the end of joints in accordance with best welding practice to produce sound welds and a consistent joint. If needed or required by the welding process applied, weld tabs are to be used to provide an extension of the weld joint so that termination is outside of the production welds.

Weld tabs shall be of a base metal type which is compatible with the material being welded, unless otherwise agreed.

Crevice corrosion is to be prevented by the weld design especially for austenitic stainless steels. The ends of continuous fillet welds should be seal welded (wrapped) at terminations of structural members and in way of cut-outs or holes and along all edges of any provided brackets.

4.9 Back Gouging

Chipping, grinding, plasma gouging or other suitable methods are to be employed at the root or underside of the weld to obtain sound metal before applying subsequent beads for all full-penetration welds, unless otherwise agreed. If arc-air gouging is employed, a selected technique is to be used so that carbon buildup and burning of the weld or base metal is minimized. A subsequent suitable cleanup method or follow up plasma gouging is required.

4.10 Weld Cleaning

Where brushes are used, the brush wires should be stainless steel materials. If required, grinding is to be done using iron-free abrasive wheels.

All slag and foreign materials are to be completely removed from the weld and the surrounding base metal before welding over previous deposited weld metal. The crater area after welding interruption may need to be ground if cracking is an issue. Slag and harmful spatter are also to be removed from all finished products.

A suitable method is to be used to remove Arc strikes, cracks or blemishes caused by arc strikes. A smooth contour is to be ground and examined visually. Depending upon the design requirements, examination by nondestructive methods may be agreed.

5 Butt Welds

5.1 Manual Welding Using Covered Electrodes

Manual welding using covered electrodes may be employed for butt welds in members not exceeding 3.2 mm (1/8 in.) in thickness without beveling the abutting edges. Members exceeding 3.2 mm (1/8 in.) are to be prepared for welding acceptable to the Surveyor by using an appropriate edge preparation, root opening and root face (land) for welding from one or both sides. For welds made from both sides, the root of the first side welded is to be removed to expose sound metal by an approved method before applying

subsequent weld passes on the reverse side. In the case that welding is to be deposited from one side only, practical welding techniques and appropriate backing (either permanent or temporary) are to be provided. The backing is to be fitted so that spacing between the backing and the members to be joined is in accordance with established procedures. Unless specially approved otherwise, splices in permanent backing strips are to be welded with full penetration welds prior to making the primary weld.

5.2 Submerged-arc Welding

Submerged-arc welding using wire-flux combinations may be employed without beveling the abutting edges for butt welds in members not exceeding 8 mm (5/16 in.) in thickness for single pass and 16 mm (5/8 in.) in thickness for two passes. Members exceeding these thickness limits are to have edge preparation, root opening and root face (land) for welding acceptable to the Surveyor. In the case that welding is to be deposited from one side only, practical welding techniques and appropriate backing (either permanent or temporary) are to be provided. The backing is to be fitted so that spacing between the backing and the members to be joined is in accordance with established procedures.

5.3 Gas Metal-arc and Flux Cored-arc Welding

Semiautomatic or mechanized gas metal-arc welding and flux cored-arc welding using wire-gas combinations and associated processes may be ordinarily employed utilizing the conditions as specified in 4-3/5.1, except that specific joint designs may differ between processes.

Short circuit gas metal arc welding (GMAW-S) may be restricted to welding thickness up to 6.5 mm (1/4 in.) unless special requirements for welder qualification are approved for higher thickness.

5.4 Gas Tungsten Arc Welding (GTAW)

Stainless steels are extensively welded using GTAW. The filler enters the weld pool without passing through the arc, and therefore, GTAW is a stable process. The weld metal is protected by inert gas. Argon is recommended up to 12 mm (1/2 in.) in thickness and Helium or Ar-He mixture is applied for thickness above this.

5.5 Special Welding Processes and Techniques

Special welding techniques employing any of the basic welding processes mentioned in 4-3/5 will also be specially considered, depending upon the extent of the variation from the generally accepted technique. Such special techniques include narrow-gap welding, tandem-arc etc. In addition, welding processes such as friction stir welding and hybrid laser welding will be specially considered.

CHAPTER 4 Welding of Stainless Steels

SECTION 4 Fabrication Verification and Nondestructive Testing of Production Welds

1 General

Quality control is to be maintained during fabrication. The shipyard or manufacturer is to perform fabrication, inspection and NDT to the quality requirements, to the satisfaction of the ABS Surveyor.

The NDT personnel are to be notified in advance for the inspection details including the material grade, detailed drawings with the size, length, type and location of all welds to be inspected, and any access restrictions. NDT personnel are to be familiar with the inspection of stainless steel welds.

The NDT personnel should be qualified to applicable standards such as AWS and ASNT. The Surveyor has authority to verify the qualification of NDT operator.

In general, the requirements of the *ABS Guide for Nondestructive Inspection* are applicable for production welds of stainless steels. Other applicable NDT standards may also be applied. However, additional details and requirements for NDT of stainless steel welds are to be included in this Section.

2 Reference Documents

ASME BPVC IX : Welding, Brazing, and Fusing Qualifications

ASNT: Nondestructive Testing Handbook

ASNT CP-189: Standard for Qualification and Certification of Nondestructive Testing Personnel

ASNT-TC-1A : Personnel Qualification and Certification in Nondestructive Testing

ASTM E165: Standard Practice for Liquid Penetrant Examination for General Industry

AWS B1.10: Guide for Nondestructive Inspection of Welds

AWS D1.6: Structural Welding Code-Stainless Steel

EN 10228: Non-Destructive Testing of Steel Forgings. Ultrasonic Testing of Austenitic and Austenitic-Ferritic stainless steel forgings

ISO 3834-2: Comprehensive Quality Requirements for Fusion Welding of Metallic Materials

ISO 3834-3: Standard Quality Requirements for Fusion Welding of Metallic Materials

ISO 5817: Fusion-Welded Joints in Steel, Nickel, Titanium and Their Alloys (Beam Welding Excluded) - Quality Levels for Imperfections

ISO 9712: Qualification and Certification of NDT personnel

ISO 14732: Qualification Testing of Welding Operators and Weld Setters for Mechanized and Automatic Welding of Metallic Materials

3 Fabrication Verification

3.1 Verification of Materials

The shipyard or fabricator is responsible for confirming that the applied materials meet all requirements, for example, steel certification and surface condition, and welding consumable certification and selection. The ABS surveyor is to verify these requirements. In case that the materials have deviations from the requirements, non-conformance reports are to be submitted to ABS for review and approval.

3.2 Verification of WPS, PQR and Welder Qualification

The shipyard or fabricator is responsible for confirming that all applied WPSs are appropriate for the production welds. The ABS surveyor is to verify WPS, PQR and welder are appropriately qualified.

The shipyard or fabricator and ABS surveyor should make certain that production welds are performed only by qualified welders or welding operators applicable to the specified WPS for the work.

In case that the quality of the welds is below the requirements, the welder or welding operator may be required to demonstrate their capability to produce sound welds by a simple test or by complete requalification.

Welder or welding operator may be requested to requalify if their qualification is not current or valid. When qualifying, the welding and qualification tests are to be witnessed by the ABS Surveyor.

3.3 Verification of Work and Records

The shipyard or fabricator is to keep a record of all WPS, PQR, WPQT, welder performance record, the control of welding materials and equipment etc.

The shipyard or fabricator should observe, at a suitable interval time, that the joint preparation, assembly, welding techniques, and performance of each welder or welding operator can meet the applicable requirements. The welds are to meet the minimum size, length, and location in accordance with drawings and specifications. The size and contour of welds are to be measured using suitable gages and meet the applicable acceptance criteria.

The ABS Surveyor is to verify that the welding speed, electrode type, positions, type of welding, welding current, polarity or other essential parameters are in accordance with WPS.

In the case that nondestructive testing is required, the NDT personnel should confirm that the procedures and techniques are in accordance with the qualified procedure. The nondestructive testing, examination and the test results evaluation is to be to the satisfaction of the ABS Surveyor. The Surveyor may request to witness the inspections. Depending upon the test results, satisfactory welds are accepted and unsatisfactory welds are to be rejected and repaired, as necessary. NDT personnel should record the description and location of all repairs, inspect the re-welding, and record NDT results after repair. The locations of repairs are to be marked on the joint.

4 Nondestructive Testing Practice of Production Welds

4.1 Nondestructive Testing Practice for Structural Welds

The following is ABS testing practice for structural welds. Other alternative standards or established shipyard/fabricator NDT practice may be considered.

4.1.1 Testing Guidelines

For stainless steel structural welds, the weld class is defined depending upon the function of member, the loads on the welds, service temperatures, corrosive environments and the consequences of failure. The weld class is divided into 0, 1, 2, 3, 4, and 5, as listed in 4-4/Table 1. The location, length and categories of welds should be clearly designated. The recommended testing guidelines for different weld class are in 4-4/Table 2.

Welds may be treated as “a lot”. “A lot” is established on the basis of welder or welding operator, WPS, time period or other conditions. Unless otherwise specified, “a lot” is to consist of a maximum ten welds or typical 1.5 m (60 in.) welds made in succession by each welder or welding operator.

Where less than 100% testing is required by 4-4/Table 2, NDT can be performed by partial testing of a weld lot, or selected sample (spot) testing of a specified weld length.

TABLE 1
Weld Classification

| <i>Weld Class</i> | <i>Description</i> |
|-------------------|---|
| 0 | Non-load carrying welds |
| 1 | Statically loaded fillet welds, tubular fillet welds, and cyclically loaded stiffener to web fillet welds |
| 2 | Cyclically loaded fillet welds, except stiffener to web fillet welds |
| 3 | Statically loaded groove welds and tubular groove welds (except welds subject to fatigue control) |
| 4 | Cyclically loaded groove welds subject to compressive stress |
| 5 | Cyclically loaded groove welds subject to tensile or shear stress and tubular groove welds subject to fatigue control |

TABLE 2
Nondestructive Testing/Examination Methods for Structure Welds ⁽¹⁾

| <i>Method</i> | <i>Application</i> | <i>Suggested Frequency⁽³⁾</i> |
|---------------------|-------------------------------|--|
| Visual Testing (VT) | Completed weld for compliance | |
| | Class 0 | 10% |
| | Class 1–5 | 100% |
| | NDT Reports | 100% |

| <i>Method</i> | <i>Application</i> | <i>Suggested Frequency⁽³⁾</i> |
|--|--------------------|--|
| Penetrant Testing (PT) | NDT-Class 0 | 0% ⁽²⁾ |
| | NDT-Class 1 | 5% |
| | NDT-Class 2 | 10% |
| | NDT-Class 3, 4 | 25% |
| | NDT-Class 5 | 100% |
| Radiographic Testing (RT) or Ultrasonic Testing (UT) | NDT-Class 0, 1, 2 | 0% |
| | NDT-Class 3, 4 | 10% |
| | NDT-Class 5 | 25% |

- 1) The frequency should be determined based on the function of member, the actual loads on the welds, service temperatures, corrosive environments and the consequences of failure.
- 2) Non-load carrying seal welds may require NDT.
- 3) If, in the case, the structure is considered as critical, 100% surface and 100% volume NDT may be required for butt welds with the plate thickness greater than 8 mm (5/16 in.).

4.1.2 Partial Sample Testing

Partial sampling, based on the number of weld joints, should be done in accordance with the percentage of frequency indicated in 4-4/Table 2. For example:

- If “a lot” consists of ten welds and the required percentage is 10%, then, one of the ten welds is to be selected randomly and 100% examined, as a minimum.
- If “a lot” consists of ten welds and the required percentage is 5%, then, one of the ten welds is to be selected randomly and 50% examined, as a minimum.
- If “a lot” consists of four welds and the required percentage is 25%, then, one of the four welds is to be selected randomly and 100% examined, as a minimum.

If partial testing of a lot reveals no unacceptable discontinuities, the entire lot of welds is acceptable. If partial testing of a lot of welds reveals unacceptable discontinuities, the entire lot of welds should be considered unacceptable and all remaining welds of that lot are to be examined.

4.1.3 Selected Sample Testing

Selected sampling, based on the weld length, should be performed in accordance with the percentage of frequency indicated in 4-4/Table 2. For example:

- If “a lot” consists of 1.5 m (60 in.) welds and the required percentage is 10%, then, one test location is to be selected randomly and 100% examined for 150 mm (6 in.), as a minimum.
- If “a lot” consists of 1.5 m (60 in.) welds and the required percentage is 5%, then, one test specimen location is to be selected randomly and 100% examined for 75 mm (3 in.), as a minimum.
- If “a lot” consists of 1.5 m (60 in.) welds and the required percentage is 25%, then, one test specimen location is to be selected randomly and 100% examined for 380 mm (15 in.), as a minimum.

If there are indications of unacceptable discontinuities, two additional locations are to be taken away from the original location from the same welded joint. If either of the two additional locations shows unacceptable defects, the entire welded joint representing the original location is to be 100% tested.

Depending upon the function of the member, the loading, the material, etc., “a lot” for selected sample testing can be longer or shorter than 1.5 m (60 in.) subject to the agreement with ABS.

4.1.4 Testing Sequence

Final visual inspection should be carried out after all required cleaning and weld dressing. All welds should be visually acceptable before performing subsequent NDT.

Testing of austenitic and duplex stainless steel welds may begin after the completed welds have cooled to ambient temperature, unless otherwise specified.

4.2 Nondestructive Testing for Pressure Vessels

Nondestructive testing for pressure vessels is to be in accordance with Section 2-4-2 of the *ABS Rules for Materials and Welding (Part 2)*, and the industry standard, code or specification, such as ASME or equivalent as applicable.

5 Nondestructive Testing

5.1 General

Reference is to be made to the *ABS Guide for Nondestructive Inspection* or other equivalent standard for the procedures and requirements for nondestructive testing of production welds.

The testing extent and the acceptance criteria of welds may be related to the material and weld criticality. Unless otherwise agreed, the following NDT methods are to be applied for stainless steel production welds. Each NDT method has limitations. The process for nondestructive testing is to be agreed before NDT is performed. If required, the information should include the categories of welds to be examined, the extent of examination of each category and the method/methods of testing.

If acceptance criteria are defined in the rules, approved drawings or other agreed standard, those defined criteria are to be followed.

In the case that the acceptance criteria are not specified, the following practices are to be applied by agreement between fabricator and purchaser:

- i) ISO 5817 Intermediate B;
- ii) Other standard or equivalent such as AWS D1.6
- iii) The recommended acceptance/rejection criteria in accordance with 4-4/5 of this document

Note:

If agreed, the acceptance criteria can be determined by fracture mechanics analysis and fitness-for-purpose as an alternative method.

5.2 Visual Testing

All austenitic and duplex stainless steel welds are to be visually inspected after the completed welds have cooled to room temperature.

The acceptable/unacceptable visual testing results are to be in accordance with 4-4/Table 3 for austenitic stainless steels and 4-4/Table 4 and 4-4/Table 5 for non-austenitic stainless steels.

5.3 Liquid Penetrant Testing

Where required by 4-4/Table 1 and 4-4/Table 2 of this document or the applicable standard/specification, liquid penetrant may be used to detect discontinuities that are open to the surface. For austenitic or duplex stainless steels, all penetrant materials are to be analyzed individually for Halogens content. The total

Halogens content is not to exceed 1% in weight. Unless otherwise agreed, the procedures for liquid penetrant testing for production welds are given in the *ABS Guide for Nondestructive Inspection* or other applicable standard such as ASTM E165.

The recommended acceptance criteria for austenitic stainless steel weldments are the same as the visual inspection in 4-4/Table 3.

The recommended acceptance criteria for non-austenitic stainless steel weldments are the same as the visual inspection in 4-4/Table 4 and 4-4/Table 5.

TABLE 3
Visual Testing Acceptance Criteria for Austenitic Stainless Steels

| <i>VT Results</i> | <i>Non-Load or Static Load</i> | <i>Cyclic Load</i> |
|-------------------|--|--|
| Crack | No cracks. | |
| Fusion | No lack of fusion between layers of weld metal, between weld and base metal. | |
| Craters | All craters are to be filled to the full cross section of the weld, except for the ends of fillet welds outside their effective length. | |
| Undercut | Undercut is not to exceed the following dimensions: 0.25 mm (0.01 in.) or 10% of thickness for material thickness < 5 mm (3/16 in.) 1 mm (1/32 in.) for material thickness ≥ 5 mm (3/16 in.) and < 25 mm (1 in.) 2 mm (1/16 in.) for material thickness ≥ 25 mm (1 in.) 2 mm (1/16 in.) is permitted for an accumulated length of 50 mm (2 in.) in any 300 mm (12 in.) in material thickness > 12 mm (1/2 in.) | Unless otherwise agreed, undercut is not to be more than 0.25 mm (0.01 in.) deep or 10% of thickness in primary members when the weld is transverse to tensile stress under any design loading conditions. Undercut is not to be more than 1 mm (1/32 in.) deep for all other cyclic loading cases. |

| <i>VT Results</i> | <i>Non-Load or Static Load</i> | <i>Cyclic Load</i> |
|-------------------|---|---|
| Porosity | <p>Fillet weld The sum of diameters of visible piping porosity 1 mm (1/32 in.) or greater in fillet welds is not to exceed 10 mm (3/8 in.) in any linear inch of weld and is not to exceed 20 mm (3/4 in.) in any 300 mm (12 in.) length of weld. Visible piping porosity may not be acceptable in corrosive environments or if there is a requirement for a leak proof weld.</p> | <p>Fillet weld In fillet welds, the frequency of piping porosity is not to exceed one in 100 mm (4 in.) of weld length and the maximum diameter is not to exceed 2.5 mm (3/32 in.). For fillet welds connecting stiffeners to webs, the sum of the diameters of piping porosity is not to exceed 10 mm (3/8 in.) in any linear 25 mm (1 in.) of weld and is not to exceed 20 mm (3/4 in.) in any 300 mm (12 in.) length of weld.</p> |
| | <p>Groove Weld Visible piping porosity is not allowed for complete joint penetration groove welds in butt joints transverse to the direction of computed tensile stress. For all other groove welds, the sum of the visible piping porosity 1 mm (1/32 in.) or greater in diameter is not to exceed 10 mm (3/8 in.) in any linear inch of weld and is not to exceed 20 mm (3/4 in.) in any 300 mm (12 in.) length of weld.</p> | <p>Groove Weld No piping porosity is allowed for complete joint penetration groove welds in butt joints transverse to the direction of computed tensile stress. For all other groove welds, the frequency of piping porosity is not to exceed one in 100 mm (4 in.) of length and the maximum diameter is not to exceed 2.5 mm (3/32 in.).</p> |
| Underrun | <p>A fillet weld in any single continuous weld is to be permitted to underrun the nominal fillet weld size specified by 2 mm (1/16 in.) without correction, provided that the undersize portion of the weld does not exceed 10% of the length of the weld. On the web-to-flange welds on girders, no underrun is permitted at the ends for a length equal to twice the width of the flange.</p> | |

TABLE 4
Visual Testing Acceptance Criteria for Non-austenitic Stainless Steels

| <i>VT Results</i> | <i>Non-Load or Static Load</i> | <i>Cyclic Load</i> |
|-------------------|---|--|
| Crack | No cracks. | |
| Fusion | No lack of fusion between layers of weld metal, between weld and base metal. | |
| Craters | All craters are to be filled to the full cross section of the weld, except for the ends of fillet welds outside their effective length. | |
| Undercut | Undercut limitations are described in 4-4/Table 5. | |
| Porosity | Porosity is not permitted for all weld classes of Complete Joint Penetration groove welds in butt joints transverse to the direction of computed tensile stress. | |
| | <p>In the case of non-load or static load, weld Classes 0, 1, and 3, the sum of diameters of piping porosity 1 mm (1/32 in.) and greater in diameter should not exceed 10 mm (3/8 in.) in any 25 mm (1 in.) of weld or 20 mm (3/4 in.) in any 300 mm (12 in.) length of weld.</p> | <p>In the case of cyclic load, weld Classes 2, 4, and 5, the maximum diameter of an indication in any 100 mm (4 in.) of weld is not to exceed 2.5 mm (3/32 in.).</p> |
| Underrun | Fillet weld size underrun is to be 2 mm (1/16 in.) maximum for 20% of weld length. | |
| | <p>In the case of non-load or static load, weld classes 0 and 1, underrun is permitted at the ends of web to flange fillet welds for a length equal to twice the width of the flange.</p> | <p>In the case of cyclic load, weld class 2, No underrun is permitted at the ends of web to flange fillet welds of girders.</p> |

TABLE 5
Recommended Undercut Criteria for Non-austenitic Stainless Steels

| <i>Weld Class</i> | <i>Base Metal Nominal Thickness, mm (in.)</i> | <i>Maximum Depth, mm (in.)</i> | <i>Undercut Maximum Length, mm (in.)</i> |
|-------------------|---|--------------------------------|--|
| 0, 1 | < 25 (1) | 1 (1/32) | Unlimited |
| | ≥ 25 (1) | 2 (1/16) | 50 in 300 (2 in 12) |
| 2, 3 | All | 2 (1/16) | Unlimited |
| 4 | All | 1 (1/32) | Unlimited |
| 5 | All | 0.25 (0.01) None Permitted | Unlimited None Permitted |

5.4 Radiographic Testing

Where required by 4-4/Table 1 and 4-4/Table 2 of this document or the applicable standard/specification, weldments can be subjected to radiographic testing (RT) for volumetric inspection. The procedures for RT for production welds are given in the *ABS Guide for Nondestructive Inspection* or other recognized standard.

Discontinuities identified as cracks in RT film are unacceptable. Other discontinuities that exceed the acceptance criteria are unacceptable. Discontinuities detected by RT are to be evaluated on the basis of elongated or rounded. An elongated discontinuity is a discontinuity where the length exceeds three times its width. A rounded discontinuity is a discontinuity where the length is less than three times its width, which may be round or irregular shaped. Unless otherwise agreed, RT acceptance criteria for stainless steel production welds is given in the *ABS Guide for Nondestructive Inspection*, ISO 5817, level B or other equivalent standard.

5.5 Ultrasonic Testing

Where required by 4-4/Table 1 and 4-4/Table 2 of this document or the applicable standard/specification, ultrasonic testing may be used to detect internal discontinuities in weldments and heat affected zones. Unless otherwise agreed, the procedures for ultrasonic testing of production welds are given in the *ABS Guide for Nondestructive Inspection* or other recognized standard. The specific requirements for ultrasonic testing for stainless steel welds are defined in 4-4/5.5 of this document.

5.5.1 Significant Factors for Effective UT

When performing UT of stainless steel welds, it is important to plan the inspection according to the production schedule and consideration is to be given to significant factors that may influence the UT process.

UT is only effective when appropriate techniques are used by an experienced operator. Effective UT is dependent upon:

- *Access to the Inspection Surfaces and the Weld Configuration.* This means the fabrication sequence and schedule of UT has to be carefully planned and coordinated in order to allow access to the inspection surfaces. For example, a cruciform joint may need to be inspected prior to full assembly of all connecting members because full inspection may be not accessible if the joint is fully completed.
- *Inspected Materials.* For example, anisotropic stainless steel material can skew UT beams. A thick cross section may need inspection from both sides in order to get maximized coverage because of wave attenuation. Error in sizing and positioning of weld flaws is larger than C-Mn steels.

- *Applied Probes.* For example, angle compression probes can be influenced by grain structure. The grain boundaries of coarse grains can scatter the signal and make it hard to detect flaws. Specialized angle probe test blocks may need to be made from the materials to be inspected.
- *Scanning Patterns.* For example, weld caps and roots may need to be ground if the inspection is from one side. It is not easy to skip a beam of the back wall to inspect the weld. The weld volume may be maximized by using an angle probe across the weld cap, along weld cap and at 0 degrees.
- *Tandem Probes.* It may be necessary to apply tandem probes in a “pitch and catch” configuration.
- *UT Procedures.* UT procedures may be specifically developed on a case-by-case basis, depending upon geometry.
- *Creeping Waves.* If creeping waves are applied, the procedure can be tailored to detect near surface flaws or root defects (if applied on the root side).

5.5.2 General

UT procedures, instrumentation and operator requirements are to be suitable to provide maximum accuracy in discontinuity evaluation and sizing. The following is recommended to be included for the maximum control in a qualified UT procedure:

- i) UT technician qualification and specific requirements for stainless steels
- ii) UT instrumentation and calibration requirements including applicable material
- iii) UT Surface preparation requirements
- iv) UT scan plan such as probe placement, movement, testing coverage, beam angle and directions relative to the weld centerline, and tested weld volume, etc.

The obtainable accuracy should be proven by the UT technician using the applicable procedures, equipment and material approved by fabricator and the ABS Surveyor.

Variations in testing procedures, equipment and acceptance criteria may be agreed before the testing. Such variations may include other grades or similar stainless steels, other thickness, weld geometries, transducer sizes, frequency of transducer, couplant, coated surfaces, testing techniques, etc.

5.5.3 Personnel

The requirements for personnel qualification are given in the *ABS Guide for Nondestructive Inspection* or other recognized standard such as ASNT, ISO 9712 or equivalent. Personnel training and qualification is to be in accordance with applicable requirements for austenitic and duplex stainless steel welds. UT personnel should have practical examination experience for stainless steel welds for accurate detection and disposition of flaws. Prior to testing, The UT operator should have access to the relevant information such as base metal type, weld joint geometry, materials thickness, welding process and any relevant repair records.

5.5.4 Equipment

UT stainless steel welds requires dedicated equipment especially the reference blocks and probes.

Austenitic and duplex stainless steels have a coarse grain structure, which can influence UT signal attenuation and discontinuity detection. Probes are recommended to use straight beam transducers and twin crystal (transmitter/receiver) compression-wave transducers of 45°, 60° and 70° for austenitic and duplex welds. In addition, a combination of similar shear-wave angle probes and creep-wave probes can be used. The shear wave probes can detect the defects open to opposite surface such as incomplete penetration, lack of fusion. Creep wave probes can detect the subsurface defects close to the scanning surface.

5.5.5 Procedure Requirements

A UT procedure should contain the essential information related to the UT method and examination techniques. The written procedure is to be qualified by testing mock up welds made by the same welding procedure, made from the same type of material, joint configuration, materials thickness, which represent the production welds. The mock up welds are to be sectioned, properly examined, and documented to prove the satisfactory performance of the procedure. The procedure and all qualifying data are to be documented and approved by a qualified technician, ASNT Level III, and the ABS surveyor.

5.5.6 Calibration Blocks

There are two categories of blocks used for calibration purpose, the IIW or ISO calibration block and the reference calibration block.

The IIW or ISO calibration blocks, US1 or MAB in Section 3, Figure 1 of the *ABS Guide for Nondestructive Inspection* or other applicable standard, shall be used for calibration of shear and longitudinal transducers, and verification of shear wedge exit point and refracted angle. These calibration blocks shall preferably have the same acoustic properties as the material to be tested.

The reference calibration blocks, shown in 4-4/Figure 1 and 4-4/Figure 2 of this document or other applicable standard, is to be the same base metal and heat treatment condition as the production welds. The standard reflector (drilled hole) should be 1.6 mm (0.064 in.) diameter side drilled hole or equivalent at $t/4$, $t/2$ and $3t/4$. The reflector may be placed in mock up weld or actual production welds. When placed in mock up welds and sections of production welds, the reflector should be in locations where it is difficult to direct sound beams and through areas of largest expected metal grains.

Note:

Reflector holes are to be drilled in both fusion lines whenever two dissimilar materials are welded to each other.

For creep wave calibration blocks, a specific reference calibration block with predetermined notches and size will be required.

The surface condition of the reference calibration blocks is to be similar to the condition of the parent materials to be examined.

FIGURE 1
Standard Reference Reflector

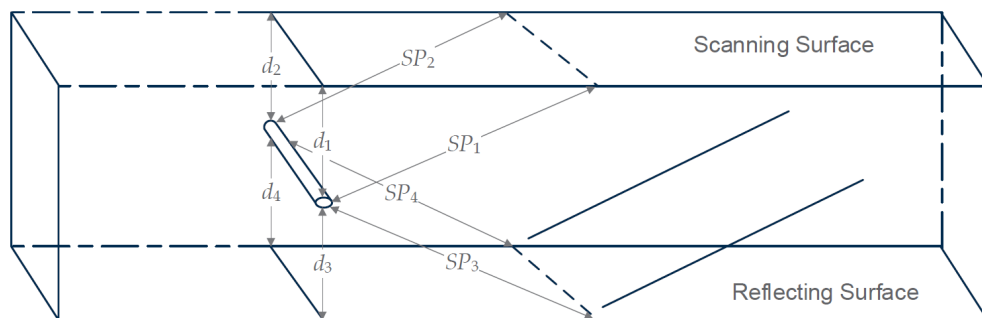

Notes:

- 1 $d_1 = d_2 \pm 0.5 \text{ mm}$, $d_3 = d_4 \pm 0.5 \text{ mm}$, $SP_1 = SP_2 \pm 1 \text{ mm}$, $SP_3 = SP_4 \pm 1 \text{ mm}$.
- 2 The above tolerances should be considered as appropriate. The reflector should, in all cases, be placed to permit maximizing the reflection and UT indication.
- 3 The diameter of the drilled hole is to be 1.6 mm (0.64 in.).

FIGURE 2
Recommended Calibration Block

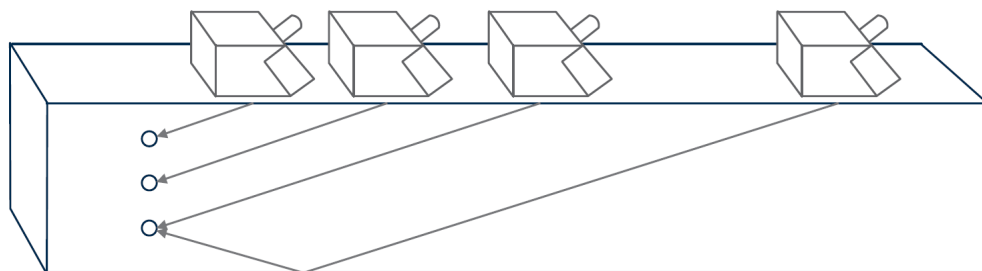

Notes:

- 1 Dimensions should be required to accommodate search units for the sound path distances required.
- 2 The diameter of the drilled hole is to be 1.6 mm (0.64 in.).

5.5.7 Calibration Methods

Unless otherwise agreed, the following calibration methods can be used for accomplishing the UT procedures. The calibration of probe delay and sound velocity are to be carried out with the use of an IIW or ISO block. Refer to Section 3, Figure 1B of the *ABS Guide for Nondestructive Inspection*.

5.5.7(a) Standard Sensitivity. “Standard sensitivity” is to contain the sum of the basic sensitivity, distance amplitude correction (DAC) and transfer correction.

Basis sensitivity indicates the maximized indication from the standard reflector.

DAC is to be determined from indications from multiple standard reflectors at depths of $t/4$, $t/2$ and $3t/4$.

Transfer correction values are an adjustment for material type, weld metal, shape, thickness and scanning surfaces. Transfer correction will capture the differences in acoustic properties, surfaces

and part shape between the calibration standard calibration blocks and the materials of the part to be tested. Transfer correction values are to be determined initially before examination and accounted for the examination.

“Scanning sensitivity” is to be “standard sensitivity” plus approximately 6 to 12 dB or as required. Unless otherwise agreed, indication evaluation is to be performed with reference to the “standard sensitivity”.

5.5.7(b) *Compression Wave*. Depth calibration using horizontal sweep is in accordance with 4-4/ Figure 3. The accuracy of calibration is to be $\pm 5\%$ of actual thickness of base metal for laminations and $\pm 2\%$ for determining discontinuity size and location.

Sensitivity calibration is in accordance with 4-4/ Figure 4. DAC curve is to be established to display the indication locations which represent the standard reflector.

FIGURE 3
Compression Wave Depth Calibration

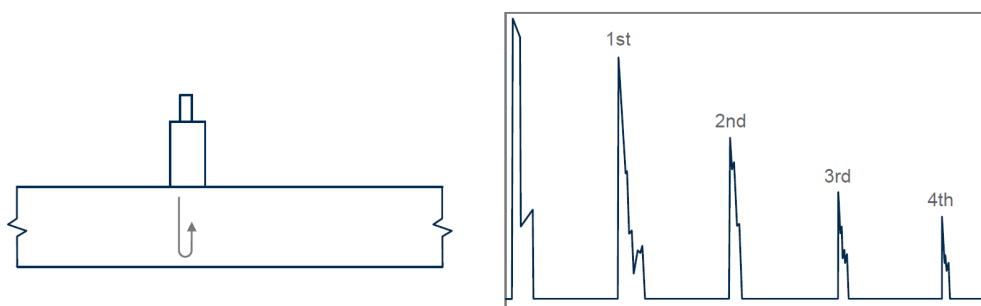
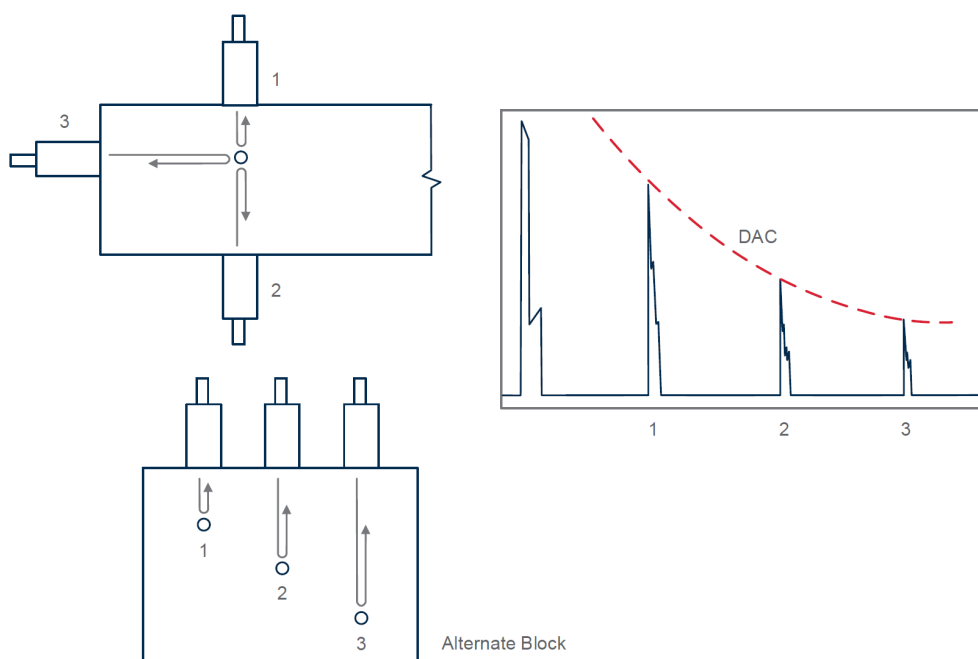

FIGURE 4
Compression Wave Sensitivity Calibration



Note: The diameter of the drilled hole is to be 1.6 mm (0.64 in.).

5.5.7(c) *Shear Wave*. The calibration method for shear wave is to be in accordance with 4-4/Figure 5 for depth using horizontal scan and sensitivity standard calibration.

For depth calibration, the indications from the selected standard reflectors are to cover the maximum depth during examination. Accuracy shall be within $\pm 1\%$ to facilitate the most accurate discontinuity height measurement. The delay technique is to be used for discontinuities with depth greater than approximately 40 mm (1.5 in.) to maximize the most accurate discontinuity depth reading and height accuracy.

For sensitivity calibration, the standard reflectors should be at the minimum, middle and maximum depths below the surface in accordance with 4-4/Figure 5. DAC or electronic methods should be maximized and established to display indication locations at the various depths. DAC is adjusted in accordance with the results of the transfer correction. The sensitivity calibration methods are not essential when actual discontinuity size (height and length) is required. The sufficient sensitivity should be maintained throughout the part for all discontinuities to be detected and properly evaluated.

5.5.8 Recalibration

Recalibration should be made after the change of operators, every 4 hours, or when the electrical circuitry is disturbed such as transducer change, battery change, electrical outlet change, coaxial cable change, power outage.

FIGURE 5
Shear Wave Distance and Sensitivity Calibration

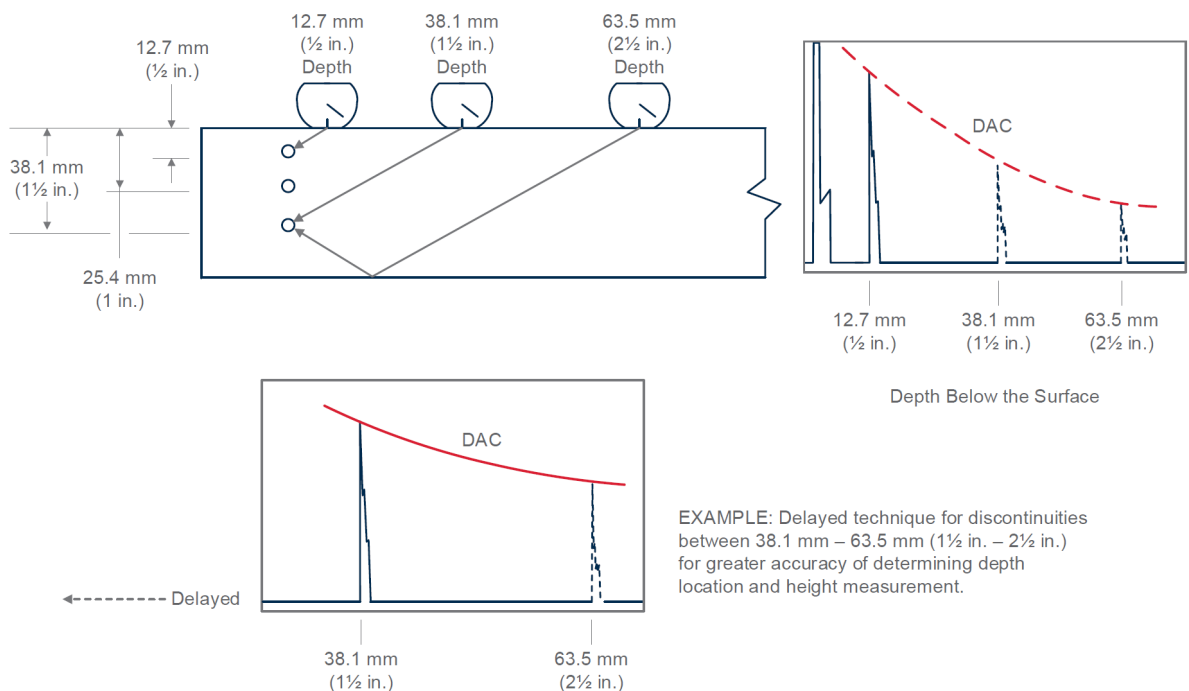

Note: The diameter of the drilled hole is to be 1.6 mm (0.64 in.).

5.5.9 Scanning Patterns and Methods

Scanning pattern should cover the full weld section. The applicable scanning patterns for various discontinuities are as follows.

5.5.9(a) *Longitudinal Discontinuities.* Scanning movement A, B and C in 4-4/Figure 6 may be applied for longitudinal discontinuities.

Rotation angle “a” is to be 10° for movement A. Scanning distance “b” is to cover the section of weld being tested for movement B. Progression distance “c” is to be approximately half of the transducer width.

5.5.9(b) *Transverse Discontinuities.* Scanning movement D and E in 4-4/Figure 6 may be applied for transverse discontinuities.

Scanning pattern D is to be used for ground flush welds. Scanning pattern E is to be used when the weld reinforcement is not ground flush. The scanning angle “e” is to be maximum 15°.

FIGURE 6
Plan View of UT Scanning Patterns

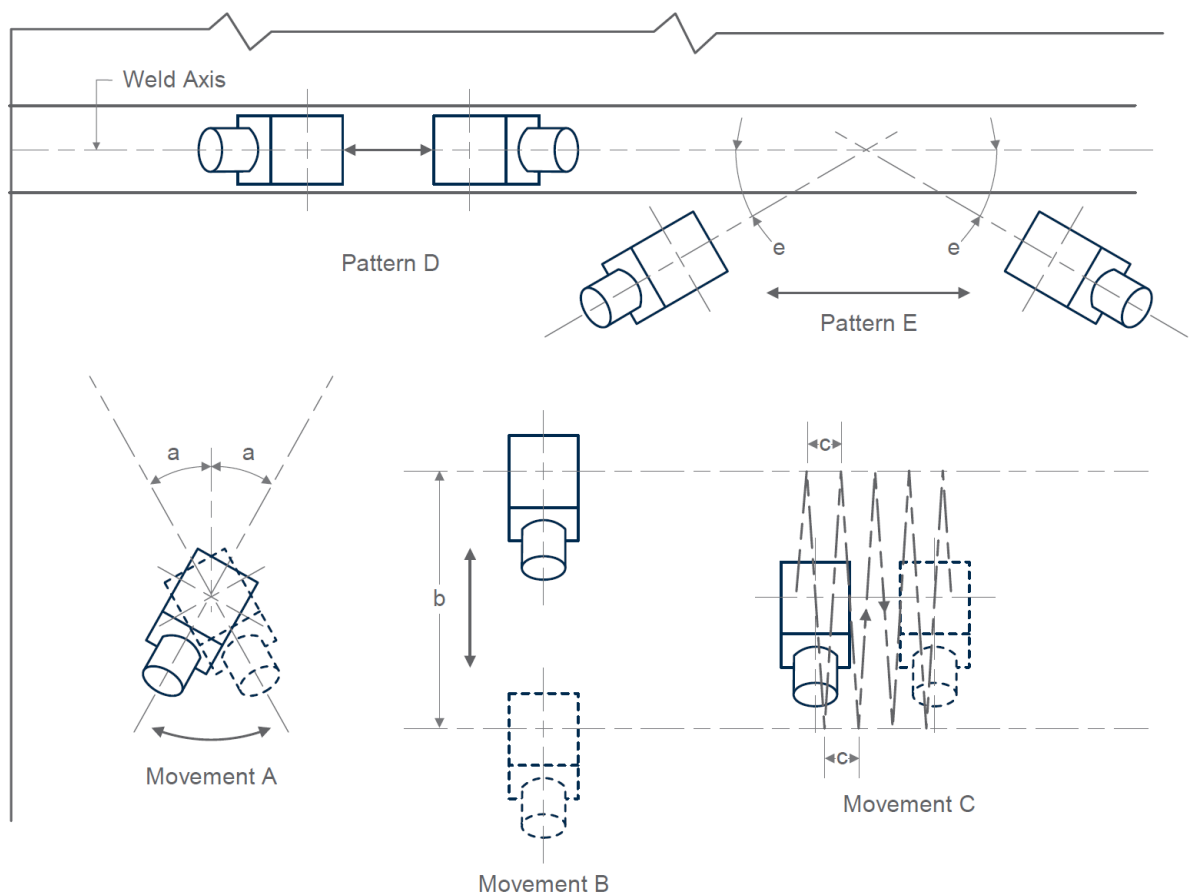

Notes:

- 1 Testing patterns are all symmetrical around the weld axis with the exception of pattern D, which is conducted directly over the weld axis.
- 2 Testing from both sides of the weld axis is to be made wherever mechanically possible.

5.5.10 Evaluation

Discontinuities are to be evaluated as follows:

- i) Type such as lack of fusion, cracks, incomplete penetration, slag, and porosity
- ii) Shape, such as planar, linear, or spherical

- iii) Size
- iv) Orientation
- v) Location

5.5.11 Acceptance Criteria

Discontinuity amplitude level categories are to be applied in 4-4/Figure 7. SSL is the standard sensitivity level. DRL is the disregard level, and is 6 dB lower than SSL.

For singular discontinuity, depending upon the weld joint type and groove design, welds categories or loading, the acceptance criteria in 4-4/Table 6 are recommended for stainless steel welds.

For accumulative discontinuity, the acceptance criteria for non-tubular products are to be referred in Subsection 3/9 of *ABS Guide for Nondestructive Inspection* and 4-4/5.1 of this document.

**FIGURE 7
Screen Marking**

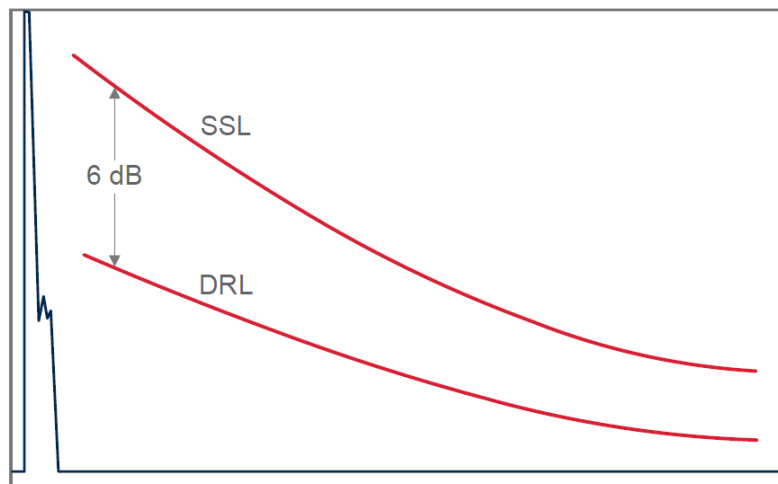

Note: The screen may be marked to show SSL (Standard Sensitivity Level) established during sensitivity calibration with DRL (Disregard Level) located 6 dB below.

**TABLE 6
Acceptable/Unacceptable Ultrasonic Testing Results for Austenitic
Stainless Steels under Static and Cyclic Loading ^(1,2)**

| <i>UT Results-Maximum Discontinuity</i> | <i>Maximum Discontinuity Lengths by Weld Classes</i> | |
|---|---|--|
| | <i>Statically Loaded</i> | <i>Cyclically Loaded</i> |
| Level 1 – Equal to or greater than SSL | > 5 dB above SSL = none allowed 0 through 5 dB above SSL = 20 mm (3/4 in.) | > 5 dB above SSL = none allowed 0 through 5 dB above SSL = 12 mm (1/2 in.) |
| Level 2 – Between the SSL and the DRL | 50 mm (2 in.) | Middle 1/2 of weld = 50 mm (2 in.) Top and bottom 1/4 of weld = 20 mm (3/4 in.) |
| Level 3 – Equal to or less than the DRL | Disregard, if specified, record for information. | |

Notes:

- 1 The screen may be marked to show SSL (Standard Sensitivity Level) established during sensitivity calibration with DRL (Disregard Level) located 6 dB below.
- 2 The tubular products are excluded from the acceptable/unacceptable UT criteria in this 4-4/Table 6.

5.5.12 Report

UT report should contain the following information related to UT method and examination techniques.

- i)* Hull number, if applicable
- ii)* Type of UT equipment (manufacturer, model and series number)
- iii)* Type of transducer, including frequency, size, shape, beam angle and type of wedge
- iv)* Scanning surface preparation and couplant requirements
Note: For austenitic and duplex stainless steels, impurities such as sulfur, halogens and alkali metals in the couplant are to be restricted
- v)* Type and identification of calibration test blocks with the appropriate reference reflectors
- vi)* Calibration method and calibration interval
- vii)* Base metal type and thickness, weld process, surface condition such as any unusual condition of weld bead (ground, undercut, etc.), weld joint design
- viii)* Acceptance criteria for the types of weld joints
- ix)* Method for examining for laminations prior to the weld evaluation
- x)* Weld root index marking and other weld marking methods
- xi)* Scanning pattern and sensitivity requirements
- xii)* Methods for determining discontinuity location, height, length and amplitude level
- xiii)* Transfer correction methods for surface roughness, surface coatings and part curvature, if applicable
- xiv)* Method of verifying the accuracy of the completed examination such as by others (audit), other NDT method, macro-etch specimens, gouging or other visual inspection
- xv)* Documentation requirements for examinations and any verifications if applicable
- xvi)* Documents retention requirements
- xvii)* Test data supporting the adequacy of the procedure
- xviii)* Date of approval of procedure by NDT Level III

CHAPTER 4 Welding of Stainless Steels

APPENDIX 1 Guidance for Handling and Storage of Stainless Steels

1 Scope (1 December 2020)

Stainless steels have a very thin corrosion protective film after pickling, which is easily damaged. In addition, these corrosion resistant stainless steels are easily contaminated and discolored by foreign materials such as free iron, grease, oil, organic matter and especially metallic particles when scraped or driven into the surface. Contamination is detrimental and thus appropriate handling and storage of stainless steels is very important at the shipyard or manufacturing site, refer to ASTM A380.

This Appendix covers handling and storage of stainless steels in shipyards or manufacturers' sites for raw materials (plates, sections, forging, casting, and pipes) during handling, storage and construction.

2 Storage

- i)* Stainless steels are to be stored separately from carbon materials in order to avoid contamination. The surface is to be dry, dust-free, and oil-free. Contact with chloride ions is to be avoided due to potential pitting and chloride stress corrosion cracking problems associated with chlorides that are left on unprotected stainless surfaces. For stainless steel pipes, the two ends are to be sealed to avoid contamination.
- ii)* Bundle straps are not to be made of carbon steel for packing stainless materials.
- iii)* Protective pads, such as wood, are to be used for storage to prevent scratching between the stainless steels and the ground. Such pads are to give uniform support to prevent deformation of steel.
- iv)* To prevent deformation, stainless steels are not to be stacked in too many layers or too high. The stacking may require intermediate supports with good alignment.
- v)* Clean shoe covers are to be worn when walking on stainless steels. Shoe covers should be removed when not walking on stainless steels.
- vi)* For Liquefied Gases application, shipyard or fabricator may have specific requirements for storage of stainless steels. For example, it may be prohibited to open packaged materials before construction. In the case that the package needs to be opened for inspection, materials are to be re-packed immediately after inspection.

3 Transportation

- i)* Stainless steels or nylon harnesses are to be used for all lifting and transporting, such as on spreaders, hooks, and plate clips.

- ii)* Appropriate steps are to be taken to prevent oil contamination of stainless steel wire lifting ropes.
- iii)* Clean wood is to be used for the temporary storage of material during the transportation process. If necessary, rubber or plastic film can be used between wood and stainless steels.
- iv)* If a forklift is used, special protection is needed for the fork head.
- v)* If lugs are welded on stainless steels for transportation, the following are to be considered:
 - Lugs are to be fully welded according to approved procedures by qualified welders. Lap welds are to be avoided.
 - If lugs are carbon steel, there is to be a suitable stainless steel transition whereby the stainless steel plate does not come into contact with the lugs. The dissimilar weld is to be of sufficient width to avoid dilution of the Carbon steel into the stainless steel parent metal.
 - Quantity of lugs is to be sufficient to enable handling but the number is to be minimized to avoid welding distortion.
 - Before and after removal of lugs, the surrounding stainless steels are to be protected.
- vi)* Before and during all lifting operations, the material package is not to be opened. If work pieces are dropped, cleaning with suitable agents are to be used, such as acetone.
- vii)* After the block construction, blocks are to be handled in such a way to mitigate structural stress and uneven deformation. Rubber or plastic film may be used between supports and the stainless steel construction.

4 Cutting

- i)* In order to prevent contamination from C and Cl, marking on the material is to be non-magnetic and chlorine-free. Materials are not to be punched or stamped.
- ii)* Clean shoe covers are to be worn when walking on stainless steels. Shoe covers should be removed when not walking on stainless steels.
- iii)* Stainless steels are to be used for supporting points or surfaces between jig and stainless steels.
- iv)* To prevent the stainless steel surface from carburization, acetylene oxygen flame cutting is not to be used. Plasma cutting is preferred.
- v)* Grinding wheels are to be suitable for mechanically cleaning and cutting of stainless steels.
- vi)* The contact areas between weld beveling machines and stainless steels are to be protected using rubber or similar to avoid iron contamination and surface damage.
- vii)* Handling tools are made of stainless steels.

5 Welding Setup

- i)* Stainless steels, nylon material or other non-contaminated material is to be used for lifting.
- ii)* Stainless steels are to be used for lugs, strong backs and clamps for weld setup.
- iii)* Supporting points of surfaces between jigs and stainless steels are made of stainless.
- iv)* Groove preps and weld gaps are to be checked to be consistent with the WPS.
- v)* Grinding and welding joint treatment is to be done by electric grinding machines. There is a risk that pneumatic grinding machines could contaminate the surfaces with oil. Use of pneumatic grinding machines is to be avoided.
- vi)* Clean shoe covers are to be worn when walking on stainless steels. Shoe covers should be removed when not walking on stainless steels.
- vii)* Ideally, surfaces are to be protected from damage from walking on them or dropped objects.

6 Forming and Bending

Cold formed materials with total strain exceeding 15% (a ratio of formed diameter to thickness less than 6:1) are to be subjected to the manufacturers' recommendations, unless it is demonstrated by testing that the material properties are acceptable in the 'as formed' condition. Hot forming and/or heat treatment is to be generally avoided since heat may damage the protective passive film and cause the sensitization. If necessary, the mechanical properties and corrosion resistance may be restored by fully solution treated followed by a rapid quench, which is quite difficult to be carried out on field.

7 Fabrication

In general, Chapter 4, Section 3 is to be referred to for stainless steel fabrication.

7.1 Environment

- i)* In marine or industrial environments, fabrication techniques are to be employed to avoid pitting corrosion, crevice corrosion, intergranular corrosion or stress corrosion cracking.
- ii)* Contact with lead/zinc, or lead/zinc compounds is to be avoided due to the potential issue of hot cracking by liquid metal embrittlement (LME) during welding.
- iii)* Seawater should be avoided as far as possible during fabrication. Seawater, especially stagnant seawater, is harmful to stainless steels because the chlorides break down the oxide layer and activate the steel. If applied for cleaning, seawater should be flushed and pumped out simultaneously using cold water. Fresh water flushing is to be performed immediately afterwards to purge all chlorides and pumped out simultaneously. Despite the fresh water flushing, there is still some active steel. Consequently, materials should be dried completely as soon as possible to mitigate the corrosion from water.

7.2 Assembly

- i)* Carbon steel components are not allowed to come into contact with the stainless steel surface directly.
- ii)* Clean shoe covers are to be worn when walking on stainless steels. Shoe covers should be removed when not walking on stainless steels.
- iii)* Internal and residual stress are to be controlled and kept to a minimum during assembly. Direct impact or knocks to the materials are to be avoided.
- iv)* Positioning lugs and fixtures are to be stainless steels.
- v)* Welding consumables used for attachment of lugs and fixtures are to be a stainless steel and suitable for parent metal.
- vi)* During fabrication operations, such as turn-over, the ends of plates or members are to be protected to avoid scratches.
- vii)* All contact areas between jigs and stainless steels are to be separated by flat or round stainless steels. The supporting areas are to be ground to avoid sharp edges.
- viii)* The fixtures quantity installed on the material is to be minimized to reduce welding deformation.
- ix)* If deformation occurs during assembly, a written procedure for correction of deformation is to be followed. Flame straightening and water quenching are not permitted.
- x)* Both sides of the assembly surfaces are to be protected from welding spattering.

7.3 Welding

- i)* All welding consumables, protective gas and essential parameters are to be in accordance with the approved WPS.
- ii)* Welding machines are to be inspected regularly by qualified welding operator and maintenance personnel.

- iii)* Welding is to be performed by qualified welders.
- iv)* Welding consumables are to be dry, protected and kept in insulated containers in accordance with manufactures requirements and recommendations.
- v)* Before welding, the surrounding surface is to be used clean and protected from the welding spattering.
- vi)* The welding sequence is to be followed strictly in accordance with fabrication instructions to mitigate distortion and weld cracking. Attention is to be paid to checking for and avoiding root cracks.
- vii)* Groove surfaces are to be descaled, clean and dried after plasma cutting and before welding.
- viii)* Base metal is not to be sustain damage that would impact the application or weld quality.
- ix)* Stainless steel wire brushes are to be used to clean welding surfaces.
- x)* Run-off tabs are to be installed on both sides of groove in accordance with manufacturers documented practice. The material, the groove and thickness are to be consistent with the welded joint.
- xi)* Arc starts and stops are to be visually inspected and associated defects are to be ground as deemed necessary.
- xii)* Crater cracks are to be ground before welding subsequent weld beads.

8 Grinding

- i)* Grinding wheels are not to contain free-iron and are to be specifically suitable for stainless steels. Wheels are to be specially marked and separated from carbon steel grinding wheels to avoid contamination. Grinding wheels that have been used for carbon steels are not to be used for stainless steel grinding.
- ii)* Grinding is to be done by electric grinding machines. There is a risk that pneumatic grinding machines could contaminate the surfaces with oil.
- iii)* Grinding personnel protection equipment (PPE) is to be complete, clean and tidy. The personnel are to have full awareness of stainless steel protection, including knowledge of cleaning and protecting tools.

9 Segmentation

- i)* Welding discoloration is to be removed by passivation paste and pickling.
- ii)* After blocks are shipped out of workshop, it may be necessary to protect stainless steels.
- iii)* If temporary safety bars, ladders and scaffolding need to be fixed to stainless steels, non-metallic materials (such as plastic soft cover) should be used for protection.
- iv)* Deformation is to be avoided during storage and moving of blocks.

10 Peening and Painting

- i)* Before peening, stainless steel surface is to be inspected and the un-peened area is to be protected.
- ii)* The peening of stainless steels is only to be used on weldments. Peening on the root, or cover passes of welds, is prohibited unless otherwise agreed.
- iii)* After peening, the loose sand and dust are to be cleaned using high pressure air.
- iv)* The groove surface is to be protected.

11 Embarkation

- i)* The inner floor of the entire stainless steel cargo surface is to be protected.

- ii)* Aluminum scaffolding is recommended. In the case that steel scaffold is used, the steel should be zinc coated and painted. The two ends are to be sealed to prevent rainwater contamination. The contact ends should be wood or rubber protected to avoid the scratches and indentation on the stainless steel surfaces.
- iii)* All stainless steel ladders, fittings, and pipes/tubes are to be cloth protected.
- iv)* Cargo holds or tanks are to be kept clean and avoid the free iron contamination at all times after fabrication. Operators must wear clear shoe covers to enter.
- v)* Scaffolding is to be removed in the correct order and safely to avoid surface damage of the stainless steels.

12 Outfitting

- i)* After the completion integrity inspection of cargo holds, the holds are to be thoroughly cleaned and kept dry.
- ii)* Access to completed cargo holds should be restricted and entry should only be granted with specific permission. Hatch covers are to be closed and tightly packed.